

ACADEMICIA

ISSN (online) : 2249-7137

## ACADEMICIA

An International  
Multidisciplinary Research  
Journal



Published by  
**South Asian Academic Research Journals**  
A Publication of CDL College of Education, Jagadhri  
(Affiliated to Kurukshetra University, Kurukshetra, India)

**ACADEMICIA**

An International Multidisciplinary Research Journal

ISSN (online) : 2249 –7137

Editor-in-Chief : Dr. B.S. Rai

Impact Factor : SJIF 2020 = 7.13

Frequency : Monthly

Country : India

Language : English

Start Year : 2011

Indexed/ Abstracted : Scientific Journal Impact Factor (SJIF2020 - 7.13), Google Scholar, CNKI Scholar, EBSCO Discovery, Summon (ProQuest), Primo and Primo Central, I2OR, ESJI, IJIF, DRJI, Indian Science and ISRA-JIF and Global Impact Factor 2019 - 0.682

E-mail id: saarjournal@gmail.com

**VISION**

The vision of the journals is to provide an academic platform to scholars all over the world to publish their novel, original, empirical and high quality research work. It propose to encourage research relating to latest trends and practices in international business, finance, banking, service marketing, human resource management, corporate governance, social responsibility and emerging paradigms in allied areas of management including social sciences , education and information & technology. It intends to reach the researcher's with plethora of knowledge to generate a pool of research content and propose problem solving models to address the current and emerging issues at the national and international level. Further, it aims to share and disseminate the empirical research findings with academia, industry, policy makers, and consultants with an approach to incorporate the research recommendations for the benefit of one and all.

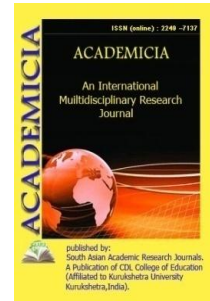

## SOUTH ASIAN ACADEMIC RESEARCH JOURNALS ([www.saarj.com](http://www.saarj.com))

**ACADEMICIA: An International Multidisciplinary  
Research Journal**

**ISSN: 2249-7137 Impact Factor: SJIF 2022 = 8.252**

**SPECIAL ISSUE ON**

**"APPLICATIONS OF ELECTRICAL MACHINES  
AND DRIVES"**

**September 2022**



# ACADEMICIA

## An International Multidisciplinary Multidisciplinary Research Journal

(Double Blind Refereed & Reviewed International Journal)



SR. NO.	PARTICULAR	PAGE NO
1.	<b>A BRIEF INTRODUCTION OF ELECTRICAL MACHINES</b> Mr. Sreekanth Kondreddy	<b>6-15</b>
2.	<b>FUNDAMENTALS OF MAGNETIC CIRCUIT ANALYSIS: KEY CONCEPTS</b> Mr. Bishakh Paul	<b>16-28</b>
3.	<b>PRINCIPLE OF ELECTROMAGNETIC: UNDERSTANDING INDUCED CURRENTS</b> Mr. Veerappa Ravi	<b>29-39</b>
4.	<b>TRANSFORMER THEORY: PRINCIPLE AND OPERATIONS</b> Mr. Vesapogu Joshi	<b>40-52</b>
5.	<b>WORKING PRINCIPLE OF SINGLE-PHASE TRANSFORMER</b> Mrs. Ramya	<b>53-61</b>
6.	<b>OVERVIEW OF THREE PHASE TRANSFORMER</b> Mrs. Ragasudha Chundampunathil	<b>62-70</b>
7.	<b>BASICS PRINCIPLES OF ELECTROMECHANICAL CONVERSION</b> Mr. Sreekanth Kondreddy	<b>71-79</b>
8.	<b>BASIC CONCEPTS IN ROTATING MACHINES</b> Mr. Bishakh Paul	<b>80-91</b>
9.	<b>AC ARMATURE WINDINGS: DESIGN AND ANALYSIS TECHNIQUES</b> Mr. Veerappa Ravi	<b>92-100</b>
10.	<b>DC MACHINES: THEORY, CONSTRUCTION, AND OPERATION</b> Mr. Vesapogu Joshi	<b>101-109</b>
11.	<b>OVERVIEW OF DC GENERATORS AND ITS FUNCTIONS</b> Mrs. Ramya	<b>110-121</b>

12.	<b>CLASSIFICATION OF DIRECT CURRENT MOTORS</b> Mrs. Ragasudha Chundampunathil	122-136
13.	<b>SYNCHRONOUS MACHINE:THEORY, MODELING, AND APPLICATIONS</b> Mr. Sreekanth Kondreddy	137-147
14.	<b>SYNCHRONOUS GENERATOR AND ALTERNATOR: A BRIEF OVERVIEW</b> Mr. Bishakh Paul	148-161
15.	<b>SYNCHRONOUS MOTOR: THEORY, MODELING, AND APPLICATIONS</b> Mr. Veerappa Ravi	162-173
16.	<b>SPECIALIZATION INDUCTION MACHINE:PRINCIPLES, DESIGN, AND ANALYSIS</b> Mr. Vesapogu Joshi	174-185
17.	<b>STUDY OF INDUCTION MOTORS: PRINCIPLE AND APPLICATIONS</b> Mrs. Ramya	186-200
18.	<b>STARTING AND SPEED CONTROL OF THREE-PHASE INDUCTION MOTOR</b> Mrs. Ragasudha Chundampunathil	201-214
19.	<b>GENERALIZED THEORY OF ELECTRICAL MACHINES</b> Mr. Sreekanth Kondreddy	215-226
20.	<b>OVERVIEW OF ELECTRICAL ENERGY GENERATION</b> Mr. Bishakh Paul	227-235
21.	<b>MOTOR CONTROL BY STATIC POWER CONVERTER</b> Mr. Veerappa Ravi	236-248
22.	<b>UNINTERRUPTIBLE POWER SUPPLIES FOR ELECTRICAL MACHINES</b> Mr. Vesapogu Joshi	249-257
23.	<b>INTERPHASE POWER CONTROL OF ELECTRICAL MACHINES</b> Mrs. Ramya	258-272
24.	<b>TRANSIENT STABILITY OF ELECTRICAL MACHINES</b> Mrs. Ragasudha Chundampunathil	273-283



## A BRIEF INTRODUCTION OF ELECTRICAL MACHINES

**Mr. Sreekanth Kondreddy\***

\*Assistant Professor,  
Department of Electrical And Electronics Engineering,  
Presidency University, Bangalore, INDIA  
Email Id:ksreekanthreddy@presidencyuniversity.in

---

### ABSTRACT:

*Electrical machines are crucial for a wide range of sectors and uses, including power production, transportation, manufacturing, and daily consumer goods. The importance, varieties, and fundamental concepts of electrical machines are highlighted in this article's introduction. It investigates the fundamental ideas of rotating magnetic fields, electromagnetic induction, and the transformation of electrical energy into mechanical work. The final sentence of the chapter emphasizes the value of electrical machines in contemporary culture as well as their continued advancement and invention.*

**KEYWORDS:** *Electrical Machines, Electrical Energy, Electromagnetic Induction, Rotating Magnetic Field, Magnetic Field.*

---

### INTRODUCTION

Electrical machines serve a broad variety of applications in several sectors and are essential parts of contemporary civilization. They are machines that transform electrical energy into mechanical work or the opposite, allowing electricity to be used effectively for a variety of applications. These devices are essential components of everyday consumer goods, transportation, industrial operations, and power generation. Electrical machines are important because they can harness and regulate the power of electricity, a flexible and accessible kind of energy. They make it easier for electrical energy to be converted, transmitted, and used, which makes it possible for critical technology and infrastructure to operate. The world as we know it now would be very different if there were no electrical machines, and there would be much less access to electricity and its advantages. Electromagnetic induction is one of the underlying theories of electrical machines. Michael Faraday made the initial discovery of this phenomena in the early 19th century, and it serves as the foundation for the operation of several electrical devices. When a conductor, such as a wire, travels through a magnetic field or when the magnetic field passing through a conductor changes, electromagnetic induction takes place. As a result, the conductor produces an electromotive force (EMF) or voltage, which causes an electric current to flow.

Another key idea in electrical devices is rotating magnetic fields. Electrical devices may produce mechanical motion by generating rotating magnetic fields. This is accomplished via the interplay of magnetic fields generated by coils or magnets with the machine's conductors. The machine's ability to produce mechanical work is made possible by the torque produced when the spinning magnetic field generates currents in the conductors[1]–[3]. There are many distinct kinds of electrical devices, each of which is created for a particular purpose and functions according to a separate set of rules. Transformers, motors, alternators, and generators are a few typical examples. While motors perform the reverse by converting electrical energy into mechanical

energy, generators are devices that change mechanical energy into electrical energy. Alternators are made particularly to produce alternating current (AC) electricity, whereas transformers are used to convert electrical energy between various voltage levels. One of the most common uses for electrical machinery is power generating. Generators are used in power plants to transform the mechanical energy of turbines or engines into electrical energy, regardless of whether they use fossil fuels, nuclear energy, or renewable energy sources. The energy required for lighting, heating, cooling, and operating various appliances and equipment is then delivered by this electricity via power networks to homes, companies, and industries. Another industry where electrical equipment is important is transportation.

Electric motors are frequently utilized in hybrid and electric vehicles (EVs) to provide propulsion. These motors transform electrical energy from the battery or fuel cell of the car into mechanical energy, which drives the wheels and propels the car forward. Electrical machinery is also necessary for the conversion of electrical energy into the rotating motion of the wheels on electric trains and trams. Electrical machines are used in industrial operations for a variety of purposes. Conveyor belts, machinery, and procedures are all operated by them in manufacturing facilities. Other examples of devices that use electrical energy for mechanical tasks in industrial settings are electric pumps, compressors, and fans. Electrical machines are the best choice for addressing the wide range of needs of industrial processes because of their adaptability and controllability. Additionally, electrical gadgets have a big influence on common consumer goods. Electrical machines are at the heart of the operation of a wide range of devices, including electric shavers, cellphones, computers, and domestic appliances like refrigerators, washing machines, and air conditioners.

These devices make it possible to transform electrical energy into the appropriate types of labor, such as electronic data processing, mechanical rotation, or refrigeration. Electrical machines are essential to the development of modern civilization because they enable advancements in consumer technology, transportation, industrial operations, and power generation. They make it easier for electrical energy to be converted into mechanical work and vice versa, enabling the operation of critical devices and infrastructure. Electrical machines have completely changed how we produce, transfer, and use electrical power by utilizing the concepts of electromagnetic induction and rotating magnetic fields. Enhancing machine performance, increasing energy efficiency, and finding sustainable and greener energy solutions all depend on ongoing research and innovation in this area. Electrical machines will keep developing, enabling new technical developments and influencing the future of many societal areas.

### **Electrical Machine**

Both useable electricity and usefully large amounts of it cannot be stored naturally or in any practical way. So, in order to fulfill the demand at all times, it must be created continually. Converting mechanical power into electrical form in a revolving machine called a generator is an effective and practical approach to create electric power. A minor amount of electricity is wasted in the generator throughout the process efficiencies in big generators are above 90%. The mechanical power is generated from heat energy using a steam turbine with an efficiency that is currently capped at 40–50% or a hydraulic turbine that converts water's potential energy with very little loss. The prime mover, a steam or hydraulic turbine, is the fundamental source of mechanical power. In addition, it is possible to produce electricity directly from hot gases in the

form of plasma, eliminating the need to convert heat energy into intermediary mechanical energy. This procedure is currently in the testing phase. Figure. 1 roughly depicts the electromechanical method of producing electricity under constant conversion circumstances.

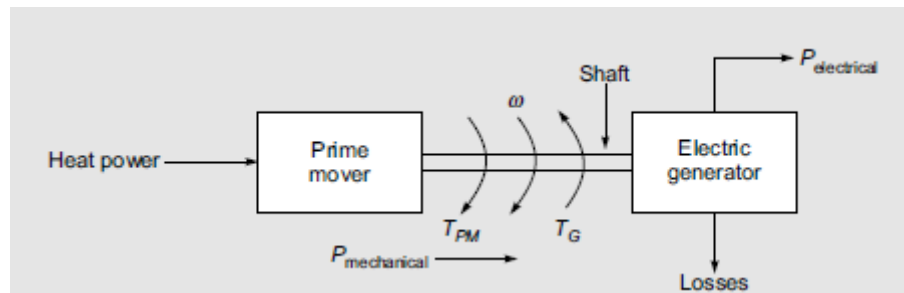

**Figure 1: Representing the Electric Generator**

The turbine and generator run at constant speed because  $T_{PM}$  (prime mover) =  $T_G$  (generator).

The primary purpose of electric energy, aside from lighting and warmth, is to transform it back into mechanical energy so that it may power small domestic appliances and the machinery of industry. The utilization of huge, effective central producing stations is made possible by the intermediate, the electric power, which is also conveniently transmitted to the multitude of consumption sites. It is possible to reverse the electromechanical energy conversion process. The flow of power is reversed via simple mechanical shaft and electrical condition adjustments seen in Figure 2. The electromechanical component, commonly referred to as the electric machine, is known as the motor in this mode of operation, and the machine is said to be in the motoring mode. Again, while operating at constant speed,  $T_M$  (motor) =  $T_L$  (load). The electric machine experiences losses in both the producing and driving modes, yet overall conversion efficiencies are quite high around or above 90%. In practically every industrial and manufacturing operation, electric machines are used. Applications for electric machines range from massive generators (500 MW and more), industrial motors with power outputs up to a few megawatts, fractional-kW home appliances, and complicated aerospace applications needing high operational dependability.

This book addresses the crucial subject of electric machines, whose thorough comprehension is required to address the issues of energy, pollution, and poverty that currently face the whole human race. Engineers have worked tirelessly and effectively to lower the size and revise higher the efficiencies of electric machines by using improved materials and ideal design techniques since Thomas Alva Edison invented an electric generator more than a century ago. We appear to have come quite near to the natural world's upper limit [4]–[6]. Electric energy is transformed from one ac voltage level to another by a static device called a transformer. Due to this gadget, practically everyone now uses an ac electric system. Electricity is produced at relatively low voltages (33 kV at most), which are subsequently boosted to extremely high voltages (756 kV, for example), before being transferred. Low currents and fewer transmission losses are related to high voltages. The electric power is converted back to safe low utility voltages (400/231 V) when it is geographically close to the usage sites. The core of a transformer is a magnetic (steel) core that firmly couples two coils or three sets of coil pairs for a three-phase system together.



## DISCUSSION

### Basic Principles of Electrical Machines

Electromagnetic induction and the creation of rotating magnetic fields are the fundamental tenets of electrical devices. The functioning of many different kinds of electrical machinery, such as generators, motors, transformers, and alternators, is based on these principles. Here is a summary of these guidelines:

- 1. Electromagnetic Induction:** When a conductor passes through a magnetic field or experiences a change in the magnetic field, electromagnetic induction causes a voltage or electromotive force (EMF) to be induced in the conductor. Michael Faraday made the initial discovery of this phenomena. Faraday's law states that the intensity of the induced voltage is inversely related to the rate at which the magnetic field is changing or the speed at which the conductor is cutting the magnetic field.
- 2. Magnetic Fields:** Permanent magnets or the movement of electric current via conductors can produce magnetic fields. These fields have a strength and direction attached to them. Magnetic fields are essential to the interplay of electrical energy and mechanical motion in electrical devices.
- 3. Rotating Magnetic Fields:** Electrical machines frequently use rotating magnetic fields to transform electrical energy into mechanical work or the other way around. The device generates a rotating magnetic field that causes currents to flow through neighboring conductors, producing torque and mechanical motion. There are several ways to rotate the magnetic field, including utilizing multiple phase windings or three-phase AC electricity.
- 4. Motors:** Electrical equipment called motors transform electrical energy into mechanical energy. They work using the electromagnetic induction theory. A force that produces mechanical motion is experienced by a conductor when an electric current is running through it while it is in a magnetic field. A variety of mechanical loads, including fans, pumps, and machines, may be driven using this motion.
- 5. Generators:** On the other hand, generators transform mechanical energy into electrical energy. For the purpose of generating an output voltage or electrical energy, they make use of the electromagnetic induction principle. An EMF is induced in a conductor when it is spun in a magnetic field or when a magnetic field is transferred across a conductor that is stationary, producing electrical power.
- 6. Transformers:** Transformers are tools for transferring electrical energy between various voltage levels. They operate via mutual induction between two sets of coils and electromagnetic induction principles. Transformers are able to step up or step down the voltage levels while preserving the power balance by altering the number of turns in each coil and the magnetic characteristics of the core material.
- 7. Alternators:** Alternators are electrical devices created particularly to produce alternating current (AC) electricity. They function via rotating magnetic fields and electromagnetic induction. AC power is produced by alternators, which are made up of spinning magnetic fields that cause voltages to be induced in stationary coils.

To understand how electrical machines work and behave, it is imperative to know these fundamental concepts. These ideas serve as the cornerstone for electrical machine design, operation, and optimization in a variety of industrial applications.

### Types and constructional feature of electrical machines:

The dc machine, the polyphaser synchronous machine, and the polyphaser induction machine are the three primary types of rotating electric machines. In order to conduct magnetic flux, conduct electric current, and insulate the voltage created in conductors that currents are confined to, three materials—steel, copper, and aluminum—are primarily employed in the manufacturing of machines.

As shown in Figure 3, all electric machines are made up of two parts: the rotor, which is a cylindrical rotating component, and the stator, which is an annular stationary element. The axial shaft of the rotor is supported by end covers fastened to the stator that house bearings at either end. The shaft often protrudes from the end cover at one end and is connected to either the load or the primary mover. Steel, a magnetic material that carries magnetic flux, serves as both the stator and rotor of an energy conversion device. The primary field is produced by field poles stimulated by direct current in both synchronous and dc devices. The term "field winding" refers to the winding on the field poles. The second winding in the opposite component produces emf when the field moves relative to it. Depending on the circuit circumstances, the winding exchanges current with the external electric system. The machine's load power is handled by this winding, known as the armature winding, whereas the field winding only uses a small portion (0.5% to 2%) of the rated load power. The load current is the armature current that varies with load.

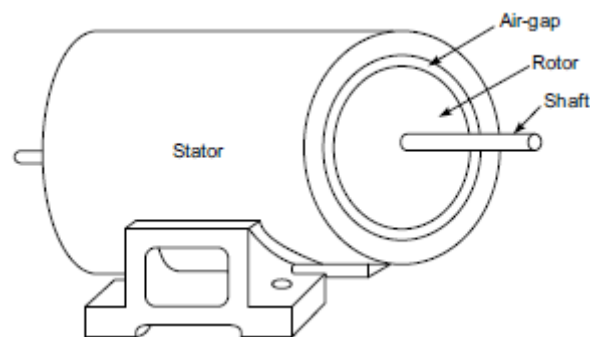

**Figure 2: Representing the Electric motor [EEE Guide].**

As can be seen in the cross-sectional view of Figure 3, the field poles of a DC machine are located on the stator, while the rotor is the armature. The field poles alternately point north and south and are symmetrical and even in number. The commutator, a spinning mechanical switch that is tapped by stationary carbon brushes, converts the alternating emf and current that are induced in the armature winding as it spins into dc form. The commutator is cylindrical in shape and is made up of many wedge-shaped copper segments that are joined together but kept separate from one another. The insulated armature winding is accommodated by slots that have been carved out of the laminated steel armature's perimeter. Each armature coil's ends produce a closed winding when coupled to the commutator segments. Current flowing through the armature creates stationary poles (equal to the amount of field poles), which interact with the field poles to create the magnetic force electromagnetic [7]–[9].

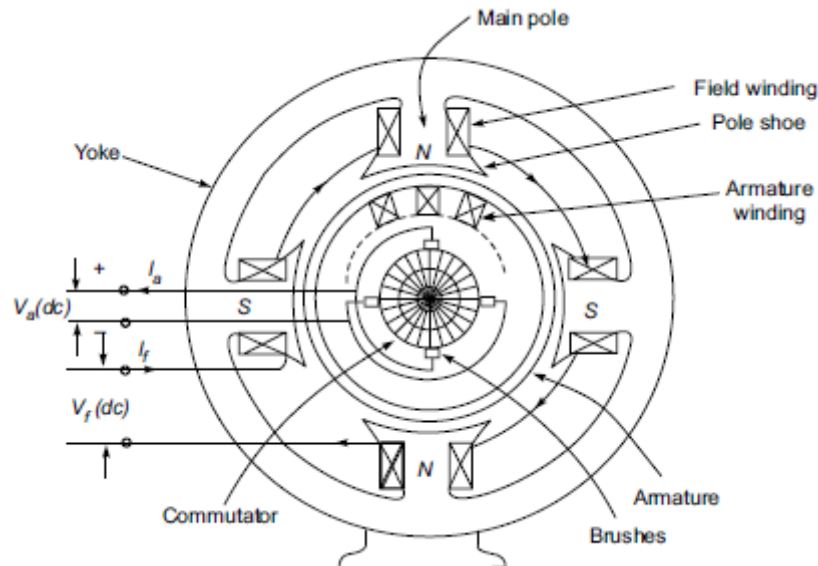

**Figure 3: Representing the Cross-sectional view of DC machines[EEE Guide].**

The field poles of a synchronous machine might be mounted on either the stator or the rotor, but in all real machines, the field poles are carried by the rotor, as shown in the cross-sectional view of Figure 4. Direct current is used to excite the field poles. A three-phase winding wound for the same number of poles as the rotor is carried by the stator, which serves as the armature. With the same angular displacement between any two phases, all three phases have the same windings. The rotor creates an alternating emf in each phase as it rotates, generating a balanced set with a frequency determined by

$$f = nP/120.$$

$f$  = frequency in Hz, where

Rotor speed in rpm equals  $n$ .

$P$  = the quantity of field poles

The rotor speed is referred to as the synchronous speed because there is a set relationship between it and the stator frequency for a certain number of poles. The armature winding creates a synchronously revolving field that is stationary with respect to the rotor field when balanced 3-phase currents are allowed to flow through it. As a result, the machine generates electromagnetic torque. However, the synchronous motor does not self-start. While the field is stimulated by low power dc in both synchronous and dc machines, the power handling capability is governed by the voltage and current of the armature winding. These machine kinds are therefore twice as eager. An induction machine is energized singularly from 3-phase mains on the stator side, which is quite different from these. So, both the load current and the excitation current necessary to produce the field must be carried by the stator winding. Similar to the armature winding of a synchronous machine, the stator winding is three-phase. It generates a synchronously spinning field when energized. The kind of induction motor is determined by one of two rotor architectures that are used.

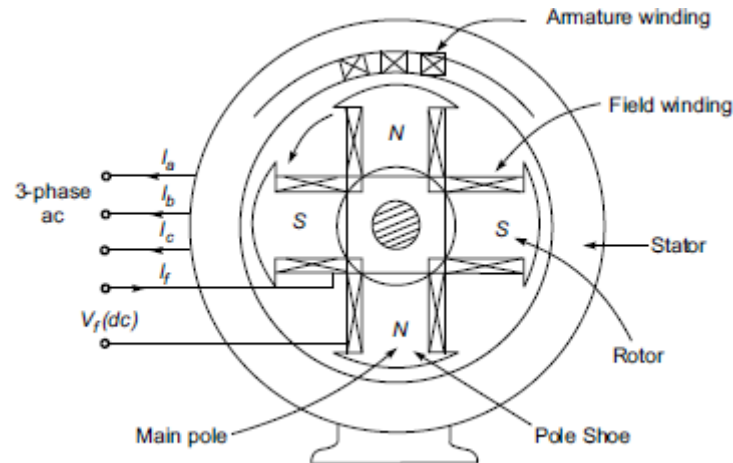

**Figure 4: Representing the Cross-sectional view of synchronous machine. [EEE Guide].**

**1. Squirrel-Cage Rotor:** This rotor, which is seen in Figure 5, includes copper (or aluminum) bars inserted in slots that are short-circuited at either end. Although it has a sturdy, cost-effective build, the beginning torque is minimal.

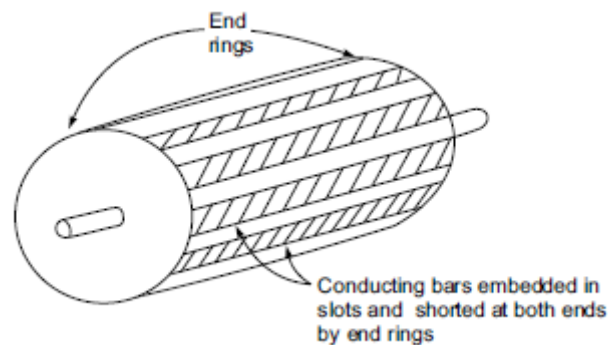
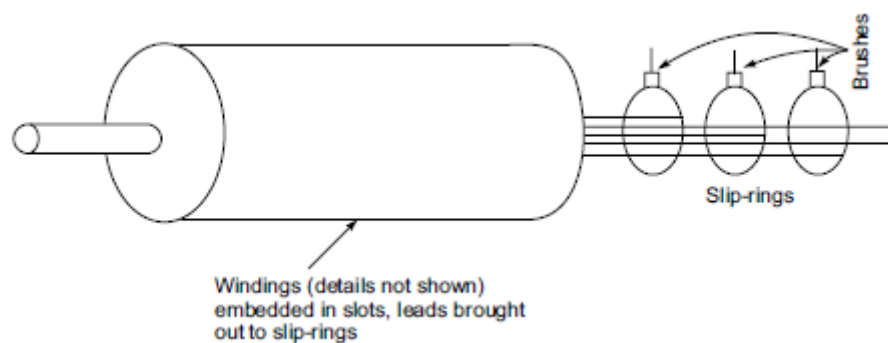

**Figure 5: Representing the Squirrel cage rotor [EEE Guide].**

**2. Slip-Ring Rotor:** As seen in Figure. 6, the rotor has a suitable three-phase winding with three leads exiting through slip-rings and brushes. Normally, these lines short circuit when the motor is operating. In order to increase the beginning torque, resistances are added to the rotor circuit via the slip rings. The shorted rotor conductors are passed by the spinning field the stator winding produces, causing currents to flow through them. These induced currents generate a separate field that spins in synchrony with the stator's field at the same speed (synchronous). These two essentially motionless fields interact to create torque. The rotor rotates at a speed that is almost synchronous but always a little slower. Zero relative speed between the stator field and the rotor at the synchronous speed means that no induced rotor currents and hence no torque may arise. For low-voltage, low-power applications fractional-kW motors single-phase ac motors are used.

They work on the same fundamental principles as a three-phase motor, but because of extra losses caused by the pulsating single-phase field and the pulsating torque component, the motor's noise level is increased. When operated at super synchronous speed, an induction machine linked to the mains acts as a generator that supplies energy to the electrical grid. It is utilized in wind

and aeronautical applications as well as small hydroelectric power plants. A machine's most susceptible component is its insulation since it cannot withstand stress over a certain temperature. The machine loading, the resulting power loss which manifests as heat, and the cooling offered all affect the constant temperature rise for a given frame size. As a result, the permitted temperature rise, often known as the machine's rating, for a certain frame size sets a restriction on the maximum machine loading depends on the type of insulation being utilized. Poor commutation reversal of current in armature coils in high-speed dc machines may become a limiting problem before the temperature limit is reached. Due to the produced centrifugal forces, speed itself may be a limiting issue in very high-speed devices. In contrast to the tough rotor induction motor, this restriction is stricter in dc machines with complex armature structure. Machines are fairly capable of withstanding a good number of overloads for brief periods due to their high thermal capacity.



**Figure 6: Representing the Slip-ring rotor [EEE Guide].**

**Motor Control:** The systems and components used to drive spinning machinery are incredibly diverse and varied. Simple start/stop operations or the management of one or more motor output characteristics, such as shaft speed, angular position, acceleration, shaft torque, and mechanical power output, may be the goal of a motor control. The range, quality, and precision of electronic motor control have nearly reached limitless levels because to the quick development of solid-state power supplies, integrated circuits, and affordable computer modules. For nuclear power and space applications, machines and other electromechanical systems with the highest accuracy and dependability feasible have been designed. Plans have been developed to quickly start, halt, or reverse megawatt-sized dc motors using solid-state power converters. Finally, when non-traditional and renewable energy sources like solar, wind turbines, etc. become more affordable, functional electromechanical energy converters with the corresponding properties will be needed.

**Economic and Other Consideration:** Economic factors have a significant role in the selection of electric machines and the related control equipment, just as in other devices. This selection may favor a high-efficiency, expensive motor, especially in a climate with growing energy costs. The trade-off between the original capital expenditure and the running and maintenance cost must be taken into account. In addition to the mechanical noise produced by the spinning machinery due to bearings, windage, etc., the transformer also creates magnetic noise. The decibel noise level in today's noise pollution levels can have a significant role in vehicle choice. This book, which focuses on electromechanical principles and the theory and application of electric machines, including transformers, does not address these issues[10].



**Research and Developments in Electrical Machines:** With the right electric drives, designing and operating electrical equipment becomes simpler and less expensive. This electric drive transforms and supplies the machine's input energy in accordance with the intended operation. The brain of the driving system that makes use of power semiconductor devices is a power electronic converter. These converters assist with changing the form of power. To efficiently convert and regulate the energy, many improvements in converter topologies and control techniques have been proposed. To make the control the most precise and quick, more clever approaches including neural networks, artificial intelligence, expert systems, fuzzy logic, and evolutionary computing are applied. The power quality at the supply end has also been enhanced via research into converter topologies. Along with efficient ac-dc converters for power factor enhancement in electric drive systems, several multiples and multilayer power electronic converters have been created to increase power quality.

Compared to other types of energy systems, electrical energy provides the most adaptable, affordable, and efficient means of power generation, transmission, distribution, and consumption. The majority of the energy needed for human activities continues to be produced by electrical equipment, ranging in size from the extremely massive generators found in power plants to the very small motors used in car control systems. Research on isolated asynchronous generators as alternative power sources, converting from wind energy, biogas, hydro units, and biomass, has gained momentum in response to the rapid depletion and rising expense of traditional fuels. The greatest alternatives for delivering energy to remote places where grid supply is inaccessible are asynchronous generators since they have benefits like low cost, little maintenance, and brushless designs. Variations in consumer loads and changing wind speeds cause voltage and frequency variations at the generator terminals in a wind-energy conversion system. As a result, the controller must be able to regulate the voltage and frequency of separate generators under changing circumstances. For constant-speed, constant-power applications, many voltage and frequency controller types are suggested. Using permanent magnet direct-drive technology, friction, vibration, and noise may be avoided in industrial drives. High performance and applications requiring a wide range of speed variations are better suited for both ac and dc PM motors. Higher torque and low speed motors are highly valued. These are the PM brushless motors. Because of numerous innovations and rising industries including wind energy, marine, traction, and offshore, the market for electric machines is expanding quickly.

## CONCLUSION

In conclusion, electrical machines are essential to our contemporary society since they provide energy for countless commercial, residential, and industrial processes. Their capacity to transform electrical energy into mechanical labor makes it possible for a variety of equipment and systems, from large-scale power plants to simple home appliances, to function. Electrical devices lay the groundwork for effective energy conversion by utilizing electromagnetic induction and producing rotating magnetic fields. For better energy efficiency, increasing machine performance, and meeting the rising demand for power, ongoing research and innovation in this area are crucial. Electrical equipment will keep developing as technology does, making it possible to find cleaner, more sustainable energy sources and advancing a variety of societal areas.

**REFERENCES:**

- [1] J. Pyrhöonen, V. Hrabovcová, and S. R Semken, “Introduction to electrical machine drives control,” in *Electrical Machine Drives Control: An Introduction*, 2016. doi: 10.1002/9781119260479.ch1.
- [2] A. Veltman, D. W. J. Pulle, and R. W. De Doncker, “Introduction to Electrical Machines,” in *Power Systems*, 2016. doi: 10.1007/978-3-319-29409-4\_7.
- [3] A. R. Daniels, *Introduction to Electrical Machines*. 1976. doi: 10.1007/978-1-349-15689-4.
- [4] T. A. Lipo and T. J. Higgins, “Introduction to generalized electrical machine theory,” *J. Franklin Inst.*, 1968, doi: 10.1016/0016-0032(68)90411-0.
- [5] M. Poppe, “Electrical Engineering,” in *Springer Handbooks*, 2021. doi: 10.1007/978-3-030-47035-7\_26.
- [6] J. M. Silveyra, E. Ferrara, D. L. Huber, and T. C. Monson, “Soft magnetic materials for a sustainable and electrified world,” *Science*. 2018. doi: 10.1126/science.aao0195.
- [7] G. Chicco and A. Mazza, “100 years of symmetrical components,” *Energies*, 2019, doi: 10.3390/en12030450.
- [8] V. Prakash, P. Kumar, P. K. Singh, M. Hussain, A. K. Das, and S. Chattopadhyaya, “Micro-electrical discharge machining of difficult-to-machine materials: A review,” *Proceedings of the Institution of Mechanical Engineers, Part B: Journal of Engineering Manufacture*. 2019. doi: 10.1177/0954405417718591.
- [9] R. Aydoun, G. Parent, A. Tounzi, and J. P. Lecointe, “Performance comparison of axial-flux switched reluctance machines with non-oriented and grain-oriented electrical steel rotors,” *Open Phys.*, 2021, doi: 10.1515/phys-2020-0200.
- [10] A. Shahaj, “Mitigation of vibration in large electrical machines,” *Current*, 2010.

## FUNDAMENTALS OF MAGNETIC CIRCUIT ANALYSIS: KEY CONCEPTS

**Mr. Bishakh Paul\***

\*Assistant Professor,  
Department of Electrical And Electronics Engineering,  
Presidency University, Bangalore, INDIA  
Email Id:bishakhpaul@presidencyuniversity.in

---

### ABSTRACT:

*Grasp the behavior of magnetic fields and their applications in diverse sectors requires a thorough grasp of magnetic circuits and electromagnetic induction. The basic ideas relating to magnetic circuits and induction are briefly reviewed in this chapter. It emphasizes how crucial magnetic components, including ferromagnetic cores and coils, are for building effective magnetic circuits. The chapter also examines the fundamentals of electromagnetic induction, which describes how a conductor experiences an electromotive force (EMF) when a magnetic field changes. The practical importance of magnetic circuits and induction in several technologies, such as transformers, electric motors, and generators, is emphasized in the chapter's conclusion.*

**KEYWORDS:** *Hysteresis Loss, Magnetic Field, Magnetic Flux, Magnetic Circuit, Parallel Magnetic Circuit.*

---

### INTRODUCTION

All revolving electric equipment, electromechanical devices, as well as static devices like the transformer, depend on the electromagnetic system. The purpose of the electromagnetic system is to create and manage electromagnetic fields in order to convert, process, and transport energy. Practically all electric motors and generators rely on the magnetic field as the coupling medium to enable energy exchange in either direction between electrical and mechanical systems. These devices range in size from tiny fractional horsepower units found in household appliances to enormous several thousand kW motors used in heavy industry and several hundred-megawatt generators installed in modern generating stations. Despite not being an electromechanical conversion device, a transformer offers a way to transmit electrical energy between two electrical ports using a magnetic field as the intermediary. Additionally, rotating machine analysis and transformer analysis are closely related, and a grasp of one tremendously benefits the other. Thus, it can be observed that the magnetic field serves as a medium for the conversion and transmission of energy in all electric equipment, including transformers. Essentially, the examination of electric and magnetic circuits and how they interact is what these devices are studied for. In addition, a number of other crucial devices, such relays and circuit breakers, depend on the existence of a restricted magnetic field to function. This chapter's objectives are to cover the scientific principles regulating magnetic fields, electromagnetic field induction, and the generation of mechanical force, as well as to establish techniques for magnetic circuit analysis. We'll talk briefly about basic magnetic circuits and magnetic materials. The principles from this

chapter will be shown in the subsequent chapters in the study of transformers and other devices[1]–[3].

### **Magnetic Field and Its Significance**

The impact of magnetic forces on charged particles and magnetic materials is described by the idea of the magnetic field, which is essential to physics. It is produced by moving charges or currents and is crucial to many fields of science, technology, and daily life. The magnetic field is a vector field, which means that at any point in space, it has both a magnitude and a direction. Magnetic field lines, which show the direction of the field, are used to illustrate it. These lines' density indicates the magnetic field's intensity, with denser lines suggesting a stronger field. The capacity of a magnetic field to impose forces on moving charged particles is one of its main effects. A charged particle moving through a magnetic field with a velocity vector perpendicular to the field will feel a force that is perpendicular to both the velocity vector and the magnetic field, according to the Lorentz force equation. The charged particle is propelled in a circular or helical motion as a result of this force. Particle accelerators, mass spectrometers, and other equipment that works with charged particles are all based on this phenomenon. Magnetic materials, particularly ferromagnetic ones like iron, cobalt, and nickel, are significantly impacted by magnetic fields as well.

Due to their special characteristics, these materials may become highly magnetized in the presence of a magnetic field and keep that magnetism long after the field is withdrawn. This characteristic is essential in the design of magnets used in several applications, including hard drives, MRI machines, electric motors, generators, and electric motors. Magnetic fields are important in electromagnetic induction because of their effect on charged particles and magnetic materials. An electric current is induced in a conductor when a magnetic field that is flowing through it changes. The electromagnetic induction phenomena serve as the foundation for the production of energy in power plants and electric generators. Additionally, it enables the use of equipment like transformers, which move electrical energy from one circuit to another via magnetic fields. Additionally, Earth's magnetic field encircles our world. The mobility of the molten iron, which forms a magnetic dipole in the Earth's outer core, produces this geomagnetic field.

The magnetic field of the Earth serves a number of crucial purposes. It acts as a barrier against the solar wind, a stream of dangerously charged particles, coming from the Sun. Additionally, it is essential for navigation since compasses can identify direction by aligning with the Earth's magnetic field lines. Additionally, learning more about the Earth's magnetic field helps us understand the processes and history of our planet's geology. Scientists may learn more about plate tectonics, the dynamics of the Earth's core, and the reversals of the Earth's magnetic field by examining the magnetic characteristics of rocks and sediments. The magnetic field is a fundamental idea in physics that has significant applications. It affects charged particle motion, permits material magnetization, fuels electromagnetic induction, and is essential for many different technological applications. The magnetic field is a crucial part of our comprehension of the natural world and the creation of many technologies, contributing to the generation of electricity, facilitating navigation, and offering insights into Earth's past.

## Magnetic Circuit

A closed loop of magnetic flux is referred to as a magnetic circuit. It is comparable to an electrical circuit in which current travels via components and conductors. Similar to how magnetic flux moves via magnetic materials and parts in a magnetic circuit. In a variety of sectors, such as power generation, transformers, electric motors, and generators, an understanding of magnetic circuits is crucial. A magnetic field generates magnetic flux inside a magnetic circuit. A permanent magnet or an electromagnet can produce the magnetic field. Flux lines generally go in a closed loop through ferromagnetic materials like iron or steel. Due to their high permeability, ferromagnetic materials are able to conduct magnetic flux more efficiently than non-magnetic ones. A magnetic circuit's behavior is governed by a number of essential elements. The magnetic source, the magnetic substance, and the air gap are some of these components. The magnetic material acts as a conductor for the magnetic flux, whereas the magnetic source is in charge of producing the magnetic field. A non-magnetic substance, such as air or a non-ferrous material, that blocks the flow of magnetic flux is known as an air gap.

Magnetic flux, represented by the symbol, is the primary variable in a magnetic circuit. The entire magnetic field that is present in a certain location is represented by magnetic flux. It is expressed in Weber (Wb) units. The cross-sectional area perpendicular to the magnetic field lines and the magnetic field strength are directly related to the magnetic flux. Ampere's law states that the total magnetic flux flowing through a closed loop is equal to the total current contained inside the loop times the material's permeability. It may be written mathematically as  $\Phi = NI\mu$ , where N is the quantity of coil turns, I is the current passing through the coil, and  $\mu$  is the permeability of the substance. Ferromagnetic cores are frequently utilized to increase the magnetic flux in magnetic circuits. Due to their high permeability, ferromagnetic materials can concentrate magnetic field lines and boost the effectiveness of the magnetic circuit. These cores have coils twisted around them to increase the magnetic flux. Many magnetic devices, including transformers and electric motors, are built around ferromagnetic cores and coils. Transformers are machinery that use magnetic coupling to transfer electrical energy from one circuit to another. A ferromagnetic core is encircled by two or more coils. A magnetic field created by an alternating current passing through the first coil induces a voltage in the secondary coil. This electromagnetic induction mechanism enables effective power distribution and voltage change.

Magnetic circuits are used in electric motors to transform electrical energy into mechanical energy. They are made up of a stator and a rotor. Several coils are often coiled around ferromagnetic cores in the stator. The magnetic field produced by an electric current flowing through the coils interacts with the magnetic field of the rotor Figure 1. The rotor rotates as a result of the electromagnetic forces generated, allowing mechanical work to be done. On the other hand, electric motors work on the opposite principle than generators. The mechanical energy is transformed into electrical energy by them. In a generator, the rotor spins inside a magnetic field produced by the stator. Electromotive force (EMF) is created in the stator coils as a result of changes in the magnetic field lines that pass through them when the rotor rotates. An electrical current produced by this EMF can be used as a power source. A magnetic circuit is a closed loop in which magnetic flux flows, to sum up. To increase the effectiveness of the magnetic field, magnetic components such as ferromagnetic cores and coils are used. Transformers, electric motors, and generators all depend on magnetic circuits for operation. Designing and optimizing these devices is made possible by an understanding of electromagnetic induction and



magnetic circuits, which advances power production, distribution, and a variety of industrial applications[4]–[6].

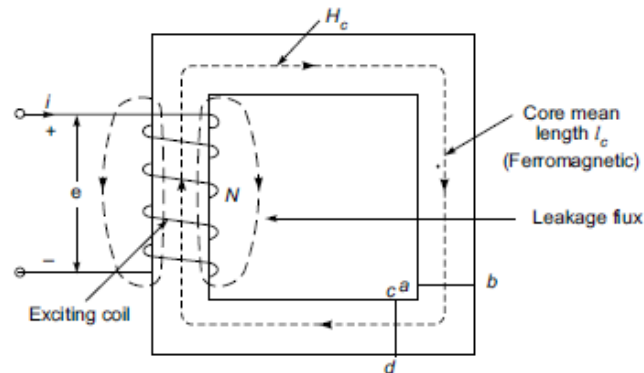

Figure 1: Representing the overview about Simple Magnetic circuit[EEE Guide].

## DISCUSSION

### Comparison between Magnetic Circuit and Electrical Circuit

Both electric and magnetic circuits are crucial ideas to understand while studying electromagnetism. Even if they are similar, they also differ greatly from one another. Here is a comparison of electric and magnetic circuits:

**Nature of the Phenomenon:** Electric circuits deal with the movement of electrons as a result of the flow of electric current via conductors. The transport and regulation of electrical energy are the main goals of electric circuits. On the other hand, magnetic circuits include the movement of magnetic flux via magnetic materials. They deal with how magnetic fields behave and are managed.

**Components:** Wires, resistors, capacitors, and inductors are examples of conductive materials that are commonly used in electric circuits. These parts are used to control the movement of electrical current and to work with electrical energy. Magnetic components such as iron or steel cores, coils, and permanent magnets are used in magnetic circuits. These parts are made to regulate and manipulate magnetic flux and fields.

**Conversion of Energy:** Electrical energy conversion into other types of energy or vice versa is the main focus of electrical circuits. Electrical energy, for instance, may be transformed into mechanical energy in electric motors or into light and heat in incandescent bulbs by means of electric circuits. On the other side, magnetic circuits concentrate on the movement and management of magnetic energy. They are engaged in the transformation of electrical energy in transformers or the conversion of mechanical energy into electrical energy in generators.

**Representation in Mathematics:** Voltage (V), current (I), and resistance (R) are commonly used to characterize electric circuits. The fundamental rules of Kirchhoff and Ohm are utilized to examine and resolve issues with electric circuits. Magnetic flux, magnetic field intensity, and reluctance are used to characterize magnetic circuits. Key concepts utilized in the study of magnetic circuits include Ampere's law and Faraday's law of electromagnetic induction.

**Behavior:** Instantaneous effects are seen in electric circuits, which means that changes in voltage and current are instantaneously sensed throughout the circuit. Typically, the behavior of electric

circuits is described using the instantaneous voltage and current values. On the other hand, magnetic circuits have a more time-delayed behavior because magnetic materials take longer to react to changes in magnetic flux. Magnetic hysteresis and magnetic saturation characteristics are frequently used to explain the behavior of magnetic circuits.

**Applications:** Electric circuits have several uses in the production and distribution of electricity, as well as in electronics, telecommunications, and control systems. Transformers, electric motors, generators, inductors, MRI machines, and other magnetic devices all make heavy use of magnetic circuits. While both electric and magnetic circuits include the flow of energy, there are differences between them in terms of the physical phenomena, components, energy conversion processes, mathematical representations, behavior, and applications. In many fields of engineering and technology, having a solid grasp of both types of circuits' properties and underlying concepts is crucial.

**Series Magnetic Circuit:** A continuous route for the magnetic flux to flow is created in a series magnetic circuit by the connection of magnetic elements or components. Similar to a series electric circuit, a series magnetic circuit's magnetic components share the same magnetic flux and experience the same level of magnetic field strength. By focusing on the following crucial elements, the behavior and analysis of a series magnetic circuit may be comprehended:

**Flux Magnetic:** The magnetic flux ( $\Phi$ ) through each magnetic component in a series magnetic circuit is constant. In a series electric circuit, it is comparable to electric current. The magnetic flux, which is measured in Weber (Wb), is the entire magnetic field that is traveling through a certain location. The magnetic flux is determined by the cross-sectional area (A) perpendicular to the magnetic field lines and the magnetic field strength (H).

**Strength of the Magnetic Field:** The magnetic field strength within a magnetic substance is represented by the magnetic field intensity (H). It is expressed in A/m, or Ampere-turns per meter. Due to their series connection, all magnetic components in a series magnetic circuit have the same magnetic field intensity. The magneto motive force (MMF) divided by the magnetic route length determines the magnetic field intensity.

**MMF, Or Magnetomotive Force:** The force that moves the magnetic flux across the magnetic circuit is known as the magneto motive force (MMF). Electromotive force (EMF) in an electric circuit serves as an analog for it. The MMF in a series magnetic circuit is the total of the MMFs across each magnetic element. It is computed by dividing the coil's current (I) by the number of turns (N) in the coil.

**Reluctance:** The opposition to the passage of magnetic flux inside a magnetic circuit is represented by reluctance (R). Resistance in an electrical circuit serves as an analog for it. A magnetic element's reluctance is determined by its size, magnetic permeability, and magnetic path length. It is directly related to the length of the magnetic route (l) and inversely proportional to the material's magnetic permeability ( $\mu$ ). The sum of the individual reluctances of the magnetic components determines the total reluctance in a series magnetic circuit.

**Magnetic Flux and Magnetic Field Intensity Calculations:** The sum of the total circuit reluctance (R) and the magnetic field strength (H) determines the magnetic flux ( $\Phi$ ) that passes through a series magnetic circuit. Using mathematics,

$$\Phi = H/R.$$

Each magnetic element in a series circuit has the same magnetic field intensity, hence the magnetic flux through each element is dictated by its unique resistance. By dividing the entire MMF by the total magnetic reluctance, the total magnetic field strength throughout the series magnetic circuit is determined. The formula for His[7]–[9]

$$H = \text{MMF} / R.$$

Based on the characteristics and arrangements of the magnetic elements involved, the analysis of series magnetic circuits entails calculating the magnetic flux, magnetic field strength, and other circuit parameters. The design and optimization of magnetic circuits for a variety of applications, such as transformers, magnetic sensors, and magnetic actuators, rely heavily on this research. All things considered, series magnetic circuits offer a methodical way to comprehend and examine the behavior of magnetic elements connected in series, enabling the effective transmission and control of magnetic flux.

**Parallel Magnetic Circuit:** Magnetic components or elements are linked in parallel in a parallel magnetic circuit to create several channels for the magnetic flux to flow. The magnetic components in a parallel magnetic circuit have distinct magnetic fluxes but the same magnetic field strength as in a parallel electric circuit. Take into account the following essential ideas to comprehend a parallel magnetic circuit's features and analysis:

**Strength of the Magnetic Field:** Due to their parallel connection, all magnetic components in a parallel magnetic circuit have the same magnetic field intensity (H). The strength of the magnetic field within a magnetic material is represented by the magnetic field intensity, which is expressed in Ampere-turns per meter (A/m).

**Flux Magnetic:** The magnetic flux ( $\Phi$ ) via each magnetic component in a parallel magnetic circuit might vary. The entire magnetic field that is travelling through a certain region is represented by the magnetic flux, which is expressed in Weber (Wb) units. The unique reluctance of the magnetic element and the strength of the magnetic field determine the magnetic flux in each parallel route.

**Reluctance:** Similar to resistance in an electric circuit, resistance (R) in a magnetic circuit denotes the opposition to the passage of magnetic flux. A magnetic element's reluctance is determined by its size, magnetic permeability, and magnetic path length. It is directly related to the length of the magnetic route (l) and inversely proportional to the material's magnetic permeability ( $\mu$ ).

**Estimating Magnetic Flux:** The overall magnetic flux in a parallel magnetic circuit is equal to the sum of the individual magnetic fluxes passing through each magnetic component. Mathematically,  $\Phi_{\text{total}} = \Phi_1 + \Phi_2 + \dots + \Phi_n$ . The magnetic field strength (H) and reluctance (R) of each individual element may be used to calculate the magnetic flux passing through it. Using mathematics,  $\Phi = \text{MMF} / R$ .

**Calculating the Strength of the Magnetic Field:** The total magnetomotive force (TMF) divided by the total magnetic reluctance yields the total magnetic field intensity ( $H_{\text{total}}$ ), which is constant for all components in a parallel magnetic circuit. The MMF, which is computed by dividing the number of turns in a coil (N) by the current (I) passing through the coil, is the total of the individual MMFs across each magnetic element.

Based on the characteristics and arrangements of the magnetic elements involved, the analysis of parallel magnetic circuits entails calculating the individual magnetic fluxes, the overall magnetic flux, the magnetic field strength, and other circuit parameters. In many applications, such as magnetic shielding, magnetic separation, and magnetic levitation systems, parallel magnetic circuits must be designed and optimized. The splitting of magnetic flux into several channels is possible in a parallel magnetic circuit. While magnetic flux might vary, the strength of the magnetic field is constant across all components. The effective distribution and control of magnetic flux for various purposes is aided by an understanding of the properties and behavior of parallel magnetic circuits[10].

**Leakage Flux:**A limited amount of flux constantly escapes into the surrounding air in all practical magnetic circuits, but the majority of the flux is always contained to the intended channel by the employment of magnetic cores. As previously mentioned, this stray flux is referred to as leakage flux. Leakage is a feature of all magnetic circuits and can never be completely eradicated. The influence of leakage flux is often neglected in calculations involving the main magnetic circuit or is empirically taken into account. Transformers and ac machines require specific leakage studies since it impairs their performance.

**Fringing:**The phenomena of magnetic field lines diverging or spreading out from a magnetic material's primary magnetic route or surface is referred to as fringing. It happens where magnetic components, such magnetic cores or permanent magnets, meet at their edges or borders. The magnetic field's search for the path with the least resistance results in fringes, which have significant effects on the design and analysis of magnetic circuits. The field lines generally follow the primary route of the magnetic material, such as a ferromagnetic core, as magnetic flux travels through it. However, the field has a tendency to spread out or bend as it gets closer to the core's edges or surfaces, producing a fringing effect. This happens because the magnetic field lines prefer to go through non-magnetic or air-filled spaces rather than the more refractory edges. The existence of fringe has the following effects:

- 1. Magnetic Field Distribution:** Fringing results in a non-uniform distribution of the magnetic field's strength along the perimeters of magnetic components. The magnetic field is less near the margins of the core than it is in the center due to the field lines' divergence. The performance of magnetic devices may be impacted by this non-uniformity.
- 2. Reluctance and Magnetic Path:** Fringing lengthens a magnetic circuit's effective magnetic path. Near the margins, the magnetic field lines have a tendency to travel a longer distance through the air or non-magnetic areas, increasing the total resistance of the magnetic circuit.
- 3. Leakage Flux:** Fringing may cause some magnetic flux to escape the core or magnetic substance. The effectiveness and performance of magnetic devices may be impacted by these leakage flux interactions with surrounding components. Fringing may cause the magnetic material to become saturated, which is known as saturation effects. Higher magnetic resistance zones are encountered as the magnetic field lines stretch out near the borders. The magnetic material may not be able to manage the increased flux density if the field strength exceeds the saturation point of the material, which might result in magnetic saturation and a possible loss of magnetic characteristics.

When creating magnetic components and circuits, designers and engineers take fringing into consideration. There are several ways to reduce the impact of fringing.

---

- 1. Curved or Rounded Edges:** By enabling the magnetic field lines' transitions to be less abrupt, shaping the edges of magnetic components can aid in the reduction of fringing. Curved or rounded edges can better direct the field lines, preventing the field from spreading.
- 2. Techniques for Field Concentration:** By adding magnetic flux guides or concentrators, such as extra magnetic materials or forms, you may assist the magnetic field be redirected and concentrated, lowering fringing and enhancing the performance of the magnet in general.
- 3. Optimized Geometries:** Minimizing the impacts of fringing may be achieved by carefully taking into account the size and geometries of magnetic components. Air gaps, interfaces, and the core's dimensions may all be altered to improve the magnetic path and lessen fringing.

Given that it has an impact on the magnetic field distribution, reluctance, leakage flux, and saturation effects, fringing is a crucial factor to take into account when designing and analyzing magnetic circuits. Performance and effectiveness may be increased in a variety of magnetic devices and systems by comprehending and accounting for fringing effects.

### Magnetization B-H Curve

The connection between the intensity of the magnetic field (H) and the density of the magnetic flux (B) in a magnetic material is depicted graphically by the magnetization curve, also known as the B-H curve or hysteresis loop. It demonstrates how the magnetic material reacts to variations in the magnetic field that is being applied. The magnetic characteristics of a material, such as its magnetic permeability, saturation behavior, and hysteresis effects, may all be learned from the B-H curve. It is often used to characterize magnetic materials, develop magnetic circuits, and investigate magnetic materials. The main characteristics and details that may be discovered from a B-H curve are as follows:

- 1. Magnetization Saturation:** The saturation behavior of a magnetic substance is illustrated by the B-H curve. The magnetic flux density first rises quickly as the magnetic field intensity increases. But beyond a certain point, the material achieves its saturation threshold, and subsequent boosts in magnetic field power only cause marginal adjustments in flux density. When a substance reaches saturation, it has used up all of its magnetic potential.
- 2. Magnetic Permeability:** The magnetic permeability ( $\mu$ ) of the material is represented by the slope of the B-H curve. How quickly a substance may get magnetized is determined by its magnetic permeability. The slope represents the permeability of the material and is a constant value throughout the linear section of the curve (below saturation). High permeability materials are more readily magnetized and have a steeper B-H curve.
- 3. Looping Hysteresis:** The hysteresis loop is a closed-loop form that is present in the B-H curve. The loop displays the material's magnetic behavior when the intensity of the magnetic field cycles from positive to negative and back. It demonstrates that even after the external field is removed, the substance still retains some magnetic. The energy lost in the material as a result of hysteresis effects is represented by the region that the hysteresis loop surrounds. Designing magnetic devices must take into account this energy loss, which is released as heat.



4. **Remanence:** The magnetic flux density that remains in the material after the removal of the external magnetic field is known as remanence ( $B_r$ ) or residual flux density. When the magnetic field strength is zero, it represents the value of  $B$  on the  $B$ - $H$  curve.
5. **Coercivity:** The coercivity ( $H_c$ ) is the amount of magnetic field force needed to completely eliminate any residual magnetization. It is an indicator of a material's demagnetization resistance.

Engineers and scientists can ascertain a material's magnetic characteristics, such as its saturation point, permeability, hysteresis effects, and behavior under various magnetic fields, by evaluating the  $B$ - $H$  curve. Transformers, inductors, and other magnetic devices must be designed and optimized using this knowledge Figure 2. It is important to note that different materials display various  $B$ - $H$  curves based on their magnetic properties and composition. Soft magnetic materials have a well-defined  $B$ - $H$  curve, high permeability, and low coercivity, making them excellent for applications requiring quick magnetization and demagnetization. Examples of these materials are iron and nickel alloys. Neodymium magnets and other hard magnetic materials have a steeper  $B$ - $H$  curve and high coercivity, which makes them advantageous for applications needing powerful permanent magnets. The  $B$ - $H$  curve, as a whole, is a potent tool for comprehending and characterizing the magnetic characteristics of materials, assisting in the design and study of magnetic circuits and devices.

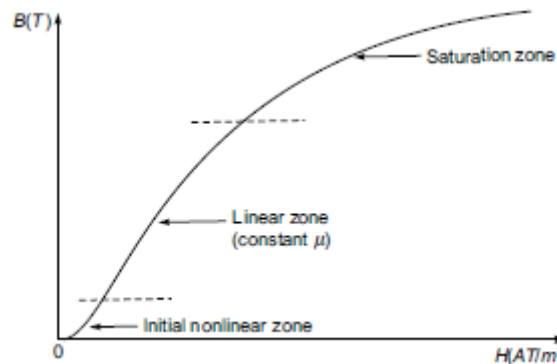

**Figure 2: Representing the B-H Curve Magnetization [EEE Guide].**

### Magnetic Hysteresis

In ferromagnetic materials, a phenomenon known as magnetic hysteresis occurs when changes in the applied magnetic field are followed by a delay in the magnetization of the material. It can keep magnetization and resist demagnetization because it has a magnetic remanence and coercivity, which govern, respectively, how well the material resists demagnetization and how well it can retain magnetization. The existence of magnetic domains inside the material gives birth to the idea of hysteresis. The individual atoms of a ferromagnetic substance, such as iron or nickel, have magnetic dipole moments that line up with one another to form discrete areas known as magnetic domains. The alignment of these domains, which behave like small magnets, controls the material's total magnetization. The domains interact with the external magnetic field and alter in magnetization as a result. The magnetic domains are initially randomly orientated when the magnetic field is zero, leading to a net magnetization of zero. The domains start to line

up with the field as an external magnetic field is applied, increasing the material's magnetization. The magnetization or magnetizing process is what causes this alignment.

More domains align when the applied magnetic field is increased, which raises the material's magnetization. The process of alignment does have a limit, though. Further increases in the applied field have minimal impact on the magnetization until the domains are well aligned. It is known as saturation magnetization when the substance can become as magnetic as possible. The magnetization of the material does not return to zero when the external magnetic field is reduced back to zero. It still has some residual magnetism, though. We call this magnetic remanence. To totally demagnetize the material, it needs an opposing magnetic field that is stronger than the coercivity. The magnetization lowers till it reaches zero if we further reduce the applied magnetic field. The coercivity of the material is at this point. The domains have now started to realign in a direction that is counter to the applied field. The domains realign once more, but in the inverse direction of their original alignment, if we increase the magnetic field in the other way. The connection between the magnetization and the applied magnetic field is represented by the material's magnetic hysteresis loop. The material's behavior during cycles of magnetization and demagnetization is displayed by the hysteresis loop. The characteristics of the material, such as its composition, crystal structure, and impurities, dictate the form of the loop. The loop's area, which measures the material's hysteresis loss, is the amount of energy that is lost as heat during the course of a whole magnetization and demagnetization cycle.

In many real-world applications, the magnetic hysteresis phenomena is essential. It is used to build hard disks and other magnetic storage systems, where the capacity to preserve magnetization is crucial for the storage of data. In order to reduce energy losses and increase efficiency, ferromagnetic cores with low coercivity and remanence are preferred in the construction of electric motors and transformers. The phenomenon of magnetic hysteresis, which is seen in ferromagnetic materials, is characterized by the magnetization trailing behind changes in the applied magnetic field. It develops because the substance contains magnetic domains. The form of the hysteresis loop, which depicts the behavior of the material during magnetization and demagnetization cycles, is affected by a number of material characteristics. For the development of many technological applications, magnetic hysteresis must be understood and controlled.

**Hysteresis Loss:** When ferromagnetic materials undergo cyclic magnetization and demagnetization processes, a phenomenon known as hysteresis loss, often referred to as energy loss or magnetic energy dissipation, takes place. It may be identified by the energy that the magnetic hysteresis loop causes to be released as heat within the material. A ferromagnetic material goes through recurrent magnetization and demagnetization when it is exposed to a magnetic field with cyclically variable strength, such as that found in an electric motor or an alternating current (AC) electrical transformer. The hysteresis loop is produced by the magnetic domains in the material realigning with the shifting magnetic field throughout each cycle. The connection between the magnetization of the material and the applied magnetic field is represented by the hysteresis loop. The magnetization growing branch and the magnetization lowering branch make up this structure. The energy lost as heat over the course of each full cycle is represented by the region contained by the hysteresis loop. Several internal properties of the material contribute to hysteresis loss. The internal friction or resistance between the magnetic domains must be overcome in order for the magnetic domains to realign with the shifting

magnetic field. Energy losses occur within the material as a result of the energy being transformed into heat.

The composition, grain structure, impurities, and coercivity of the material, as well as its composition, coercivity, and impurities, all affect how much hysteresis loss occurs. Hysteresis losses are often larger in materials with high coercivity because switching the domains' magnetization requires more energy. Additionally, because eddy current losses are lower in materials with higher resistivity, hysteresis losses are also often lower. Hysteresis loss affects electrical equipment and power systems in a practical way. This lowers the effectiveness of transformers, motors, and other magnetic devices and causes energy losses. To avoid overheating and equipment damage, the heat created by hysteresis loss needs to be dissipated. The effectiveness and efficacy of magnetic devices must thus be increased by reducing hysteresis loss. Hysteresis loss may be decreased using a variety of methods. Utilizing materials with reduced coercivity, which need less power to magnetize and demagnetize, is one strategy. Utilizing laminated cores made of thin ferromagnetic sheets is another technique that reduces hysteresis loss and eddy current losses. Improvements in magnetic materials and core designs also seek to enhance their characteristics and lessen hysteresis losses. Hysteresis loss is the term used to describe the energy lost as heat during the cyclic processes of magnetization and demagnetization in ferromagnetic materials. It takes place as a result of the material's magnetic domains realigning, and it is symbolized by the region contained by the hysteresis loop. Hysteresis loss reduction is an important topic of study and development in the realm of materials science and engineering and is essential for enhancing the effectiveness and performance of magnetic devices.

**Importance of Hysteresis Loss:** Hysteresis loss is significant because of how it affects the effectiveness and operation of magnetic devices and power systems. The following are some major justifications for why hysteresis loss matters:

**a. Energy Efficiency:** In magnetic devices like transformers, electric motors, and inductors, hysteresis loss causes energy losses. These losses result in heat dissipation, which lowers the devices' general efficiency. Increasing energy efficiency, lowering power consumption, and encouraging sustainable energy practices all depend on minimizing hysteresis loss.

**b. Heat Dissipation:** Hysteresis loss causes magnetic materials to produce heat, which dissipates. Excessive heat can lead to equipment failure, thermal deterioration, and even safety risks if it is not adequately controlled. For magnetic devices to remain reliable and last a long time, efficient heat dissipation systems and thermal management approaches are crucial.

**c. Power Transmission and Distribution:** Hysteresis loss has an impact on the effectiveness of systems for electricity transmission and distribution. In the course of converting energy, transformers essential parts of power grids suffer hysteresis losses. By minimizing energy waste and hysteresis loss in transformers, the electrical system becomes more stable and reliable while also transmitting electricity more effectively.

**d. Reduction in Size and Weight:** Hysteresis reduction has a direct impact on the dimensions and weight of magnetic components. Reducing hysteresis loss is crucial for portable gadgets, electric cars, and aerospace applications because it allows magnetic devices to be smaller and lighter without compromising performance. This factor is crucial for designing lightweight and compact systems.

**e. Thermal Stability:** Hysteresis loss has an impact on the magnetic materials' thermal stability. High hysteresis losses in materials tend to produce more heat, which increases temperature variations. Dimensional changes, the loss of magnetic characteristics, and poor material performance are all possible consequences of this. By improving thermal stability and lowering hysteresis loss, magnetic devices can operate consistently and dependably over a wide temperature range.

**f. Electromagnetic Interference (EMI):** Hysteresis loss adds to the creation of electromagnetic interference (EMI), which can impair the functionality of surrounding electronic equipment. By minimizing hysteresis loss, electromagnetic radiation output is decreased, enhancing electromagnetic compatibility and lowering the likelihood of interference.

The effects of hysteresis loss on energy efficiency, heat dissipation, power transmission, device size and weight, thermal stability, and electromagnetic compatibility are what make this phenomenon so significant overall. Researchers and engineers may create more effective magnetic materials, optimize device designs, and improve the overall performance of magnetic systems by comprehending and controlling hysteresis loss.

## CONCLUSION

In conclusion, electromagnetic induction and magnetic circuits are essential in many technological applications. The effective transmission of magnetic fields is made possible by magnetic circuits, which are made of magnetic components such ferromagnetic cores and coils. Transformers, electric motors, and generators, which are crucial parts of power production, distribution, and different industrial processes, may be designed and optimized by taking into account the behavior of magnetic circuits. On the other hand, electromagnetic induction makes it easier to transform mechanical energy into electrical energy and vice versa. Electric generator operation and the operation of electrical power networks are both based on this premise. We can continue to expand technology and boost productivity in a variety of areas by utilizing the power of magnetic circuits and electromagnetic induction, thereby advancing society as a whole.

## REFERENCES:

- [1] A. K. Bastola, M. Paudel, and L. Li, "Magnetic circuit analysis to obtain the magnetic permeability of magnetorheological elastomers," *J. Intell. Mater. Syst. Struct.*, 2018, doi: 10.1177/1045389X18781046.
- [2] S. Li, P. A. Watterson, Y. Li, Q. Wen, and J. Li, "Improved magnetic circuit analysis of a laminated magnetorheological elastomer device featuring both permanent magnets and electromagnets," *Smart Mater. Struct.*, 2020, doi: 10.1088/1361-665X/ab8029.
- [3] I. S. Song, B. W. Jo, and K. C. Kim, "Analysis of an ipmsm hybrid magnetic equivalent circuit," *Energies*, 2021, doi: 10.3390/en14165011.
- [4] W. Elsaady, S. O. Oyadiji, and A. Nasser, "Magnetic Circuit Analysis and Fluid Flow Modeling of an MR Damper with Enhanced Magnetic Characteristics," *IEEE Trans. Magn.*, 2020, doi: 10.1109/TMAG.2020.3011669.
- [5] C. Zhang, Y. Tang, Y. Xu, L. Ren, Z. Wang, and S. Liang, "Analysis of magnetic circuit and leakage magnetic field of a saturated iron-core superconducting fault current limiter," *IEEE Trans. Appl. Supercond.*, 2017, doi: 10.1109/TASC.2017.2672819.

- [6] V. Vasileva and M. Doneva, "Variational approach with transferring coefficients for magnetic circuit analysis," in *2020 21st International Symposium on Electrical Apparatus and Technologies, SIELA 2020 - Proceedings*, 2020. doi: 10.1109/SIELA49118.2020.9167103.
- [7] M. Johnson, M. C. Gardner, and H. A. Toliyat, "A Parameterized Linear 3D Magnetic Equivalent Circuit for Analysis and Design of Radial Flux Magnetic Gears-Part II: Evaluation," *IEEE Trans. Energy Convers.*, 2021, doi: 10.1109/TEC.2021.3061638.
- [8] Z. Wang, G. Li, J. Zhou, W. Tian, and H. Gao, "Contrastive analysis for magnetic circuit of a planar eddy current damper used in a vertical TMD," *Zhendong yu Chongji/Journal Vib. Shock*, 2019, doi: 10.13465/j.cnki.jvs.2019.07.033.
- [9] A. Beirami, H. F. Farahani, R. M. Rahimi, and S. Amini, "Dynamic analysis of Halbach coaxial magnetic gears based on magnetic equivalent circuit modelling," *IET Circuits, Devices Syst.*, 2021, doi: 10.1049/cds2.12023.
- [10] X. Zhang, Q. Du, J. Xu, Y. Zhao, and S. Ma, "Development and Analysis of the Magnetic Circuit on Double-Radial Permanent Magnet and Salient-Pole Electromagnetic Hybrid Excitation Generator for Vehicles," *Chinese J. Mech. Eng. (English Ed.)*, 2019, doi: 10.1186/s10033-019-0334-x.



## PRINCIPLE OF ELECTROMAGNETIC: UNDERSTANDING INDUCED CURRENTS

**Mr. Veerappa Ravi\***

\*Assistant Professor,  
Department of Electrical And Electronics Engineering,  
Presidency University, Bangalore, INDIA  
Email Id-raviangadi@presidencyuniversity.in

### ABSTRACT:

*A changing magnetic field may generate an electric current in a conductor, which is a fundamental occurrence in physics known as electromagnetic induction. When a conductor is subjected to a shifting magnetic field, a fundamental concept of physics called electromagnetic induction describes how an electric current is produced in the conductor. This idea is used in many gadgets and technologies, like as induction coils, transformers, and generators. In this chapter, we give a brief introduction to electromagnetic induction and discuss its fundamentals, uses, and importance in contemporary technology.*

**KEYWORDS:** *Electromagnetic-Induction, Eddy Current Losses, Electromagnetic Induction, Faraday's Law, Mutual Inductance, Self-Inductance.*

### INTRODUCTION

When a conductor is subjected to a shifting magnetic field, a fundamental concept of physics called electromagnetic induction describes how an electric current is produced in the conductor. Michael Faraday made the initial discovery of this phenomena in the early 19th century, and it is now widely employed in many other applications, including power generation and wireless communication. The fundamental concept of electromagnetic induction is the interaction of magnetic fields and electric currents. An electric current is induced in a conductor, such as a wire, when the magnetic field lines flowing through the conductor change when the conductor is subjected to a magnetic field. Faraday's law of electromagnetic induction governs this occurrence. According to Faraday's law, the induced electromotive force (EMF) in a circuit is inversely related to the rate at which the magnetic flux across the circuit is changing. The strength of the magnetic field, the surface area, and the direction of the magnetic field and the surface all affect the magnetic flux, which is a measurement of the total magnetic field travelling through a surface. Faraday's law may be defined mathematically as:

$$EMF = -d\Phi/dt$$

Where the negative sign denotes that the induced current opposes the change in magnetic field and EMF stands for the induced electromotive force.  $d\Phi/dt$  stands for the rate at which the magnetic flux changes [1]–[3]. Numerous electromagnetic induction applications are based on this theory. The use of electrical generators is one of the most important applications. Generators work by revolving a coil of wire in a magnetic field to transform mechanical energy into electrical energy. The magnetic field travelling through the coil changes as it spins, causing an electric current to flow through it. To power electrical systems and equipment, this current may

be captured and employed. Transformers are yet another crucial area where electromagnetic induction is used. Two coils, referred to as the main and secondary coils, are twisted around a single magnetic core to make a transformer. A changing magnetic field is produced as an alternating current (AC) passes through the main coil. This magnetic field then induces a similar alternating current in the secondary coil. Power transmission and distribution systems frequently employ transformers to step-up or step-down voltage levels, ensuring effective energy transfer over long distances. Specialized devices called induction coils use electromagnetic induction for certain objectives.

They frequently have a core composed of iron or similar magnetic substance and a coil of wire twisted around it. A rapidly varying magnetic field is produced in the core when an alternating current flows through the coil. Induction coils are beneficial in applications like induction heating, induction frying, and electromagnetic forming because this causes eddy currents and results in localized heating. Wireless communication systems use electromagnetic induction in addition to these uses. For instance, the electromagnetic induction principle underlies the operation of antennas in radio and television receivers. A radio transmission or other electromagnetic wave causes an alternating current in the antenna, which is amplified and transformed into sound or visual signals. The creation of an electric current in a conductor when subjected to a shifting magnetic field is described by the fundamental physics concept known as electromagnetic induction. It is used in many different things, including as wireless communication systems, induction coils, and electrical generators. This phenomenon may be understood and used mathematically thanks to Faraday's law of electromagnetic induction. Electromagnetic induction has played a significant role in many fields of science and technology and will continue to do so as science and technology evolve, enabling the creation of novel systems and technologies that drive our contemporary world.

**Faraday's law of Electromagnetic Induction:** The link between a shifting magnetic field and the induction of an electric current in a conductor is described by a series of fundamental rules known as Faraday's laws of electromagnetic induction. These principles, which were developed by the English physicist Michael Faraday in the early 19th century, had a significant influence on how electromagnetic was understood and used. Let's investigate these laws in more depth:

**1. Faraday's First Law of Electromagnetic Induction:** According to Faraday's first law, an electromotive force (EMF) is produced in a conductor when it is exposed to a fluctuating magnetic field. If the circuit is closed or forms a complete loop, this generated EMF results in an electric current. The rate of change of the magnetic flux going through the circuit has a direct relationship with the intensity of the generated EMF. The magnetic flux symbol represents the entire magnetic field that is travelling through a certain location. Faraday's first law may be formulated mathematically as:

$$EMF = -d\Phi/dt$$

Here, EMF stands for the induced electromotive force,  $d\Phi/dt$  for the rate at which the magnetic flux changes, and the negative sign for the induced current, which opposes the changing magnetic field.

**2. Faraday's Second Law of Electromagnetic Induction:** Faraday's second law of electromagnetic induction establishes a quantifiable link between the induced EMF and the magnetic field, building on the previous rule. This rule states that the rate of change in magnetic

field strength is exactly proportional to the size of the generated EMF. Faraday's second law may be formulated mathematically as:

$$\text{EMF} = -N(d\Phi/dt)$$

Here, N represents the number of turns in the conductor or coil, and the negative sign indicates the direction of the induced current in opposition to the change in magnetic field.

When the magnetic field is shifting unevenly or when the conductor is moving inside a magnetic field, Faraday's second law also holds true. In these circumstances, integrating the rate of change in magnetic field strength over the relevant length of time or space yields the induced EMF. These two electromagnetic induction rules provided the framework for the comprehension and advancement of numerous technologies and apparatuses. They are essential for the proper operation of electromagnetic equipment such as motors, transformers, and electrical generators. These rules served as the foundation for James Clerk Maxwell's equations, which combined the ideas of electricity and magnetism and produced the electromagnetism hypothesis. In summary, the link between a shifting magnetic field and the induction of an electric current is described by Faraday's equations of electromagnetic induction. They offer essential ideas that have transformed our comprehension of electromagnetism and have a wide range of real-world uses in the production of electricity, electrical equipment, and communication networks.

**Direction of Induced E.M.F:** As a result of Faraday's equations of electromagnetic induction, Lenz's law determines the direction of the induced electromotive force (EMF) in a conductor or circuit. According to Lenz's law, the induced EMF and current in a conductor or circuit will always flow in a direction that opposes the magnetic field shift that is creating them. In other words, the magnetic field produced by the induced current opposes the magnetic field's initial state of change. The following recommendations can be used to establish the direction of the induced EMF and current:

**1.Changing Magnetic Field:** The induced EMF will be produced in a way that opposes any changes in the magnetic field that are occurring in a wire or circuit. To try to counterbalance an increase in the magnetic field, for instance, the induced EMF will produce a current that generates a magnetic field in the opposite direction.

**2.Faraday's First Law:** The induced EMF is exactly proportional to the rate of change of magnetic flux, according to Faraday's First Law. The magnetic flux ( $\Phi$ ) is the result of the magnetic field's area and strength (B and A, respectively). Therefore, the induced EMF will be produced to counteract any changes in the magnetic field of the region.

**3.Right-Hand Rule:** The right-hand rule may be used to ascertain the direction of the induced current. Your right hand's curled fingers will show the direction of the induced current if you point your thumb in the direction of the shifting magnetic field[4]–[6].It's significant to observe that the generated EMF and current obey the concept of energy conservation rather than moving in an arbitrary direction. Energy is lost or transmitted to the circuit, preserving energy conservation, by resisting the change in magnetic field. Lenz's law, which guarantees that the induced current balances the change in the magnetic field in accordance with the fundamentals of Faraday's rules of electromagnetic induction, ultimately determines the direction of the induced EMF and current.

## DISCUSSION

---

**Induced E.M.F:**When a conductor encounters a change in magnetic field or passes through a magnetic field, an electromotive force (emf) known as induced electromotive force (ief) is produced. Michael Faraday made the initial discovery of this phenomena, which is now known as electromagnetic induction, in the 1830s. The magnitude of the induced emf is precisely proportional to the rate of change of the magnetic flux through a closed loop of wire, as stated by Faraday's equation of electromagnetic induction. The magnetic flux is an indicator of the strength of the magnetic field that is present in the loop's enclosed space. Faraday's law may be defined mathematically as:

$$\text{emf} = -d\Phi/dt$$

Where emf is the induced electromotive force,  $d\Phi/dt$  is the rate at which the magnetic flux changes, and the negative sign, in accordance with Lenz's rule, denotes the direction of the induced current or emf. The strength of the magnetic field, the size of the loop, the angle between the magnetic field and the loop, and the number of turns in the coil in the case of a solenoid or transformer can all have an impact on the induced emf. Generators, transformers, and other electrical devices that use the principles of electromagnetic induction are examples of applications for induced emf. Electrical power generation and transmission depend heavily on induced emf.

**Dynamically Induced E.M.F:**Electromotive force (emf) that is dynamically generated occurs when a conductor travels through a magnetic field or experiences a change in the intensity of the magnetic field. This kind of electromagnetic induction-based induced emf is frequently seen in a variety of electrical and mechanical systems. The magnetic flux through a conductor changes as a result of the magnetic field lines cutting across the conductor as it passes through a magnetic field. This shift in magnetic flux induces an emf in the conductor in accordance with Faraday's law of electromagnetic induction. The pace at which the conductor cuts the magnetic field lines determines the size of the induced emf. Lenz's law, which stipulates that the induced current or emf will oppose the change in magnetic flux that it created, determines the direction of the induced emf.

Accordingly, the induced emf's polarity will be such that it generates a magnetic field that is opposed to the initial change in magnetic field. Devices and applications are based on dynamically induced emf. This idea, for instance, is used by electric generators to transform mechanical energy into electrical energy. An electromagnetic field (emf) is created in the rotor windings of a generator when it rotates inside a magnetic field, producing energy. Similar to this, the conversion of electrical energy into mechanical energy by electric motors depends on dynamically generated emf. Transformers, induction heating systems, and electromagnetic brakes are other examples of dynamically induced emf. Each time, a conductor moves in relation to a magnetic field, an induced emf is created. This emf can be used for particular tasks.

**Statically Induced E.M.F:**The term "statically induced electromotive force" (emf) describes the voltage or emf that is produced when a conductor is put in a magnetic field that is either stationary or that is changing in strength. Statically induced emf is based on the interaction between a stationary conductor and a static magnetic field, as opposed to dynamically induced emf, which is caused by the relative motion between a conductor and a magnetic field. The magnetic field lines that run through a conductor alter when it is put in a magnetic field that is stationary or when the magnetic field's intensity varies. According to Faraday's law of

electromagnetic induction, this alteration in the magnetic field causes an emf to be induced in the conductor. The magnetic fields or the conductor's magnetic flux's rate of change determines how much induced emf is produced. Lenz's law governs the direction of the induced emf in statically generated conditions, just like it does for dynamically induced emf. The magnetic flux or change in magnetic field that created it will be opposed by the induced current or emf. In many applications, statically generated electromagnetic fields may be seen. For instance, a transformer's primary coil experiences an alternating current (AC), which generates a magnetic field that changes over time. Electrical energy is transferred from the primary to the secondary coil as a result of the secondary coil experiencing an emf due to the changing magnetic field. Additionally, magnetic sensors like Hall effect sensors rely on statically produced emf. The Hall effect, which is the creation of a voltage perpendicular to both a current and a magnetic field, is used by these sensors to determine if a magnetic field is present or strong. In general, even in the absence of relative motion between the conductor and the magnetic field, statically generated emf happens when a conductor is exposed to a stationary magnetic field or when the intensity of the magnetic field changes.

**Self-Inductance:** An electrical circuit's or a coil of wire's self-inductance, sometimes referred to as inductance or self-impedance, refers to their capacity to resist changes in the amount of current flowing through them. It is a basic idea in electromagnetism and is expressed in henries (H) units. A magnetic field is created around a wire or coil when a current travels through it. The coil itself experiences an electromotive force (emf) when this magnetic field interacts with the coil or wire. According to Lenz's law, this self-generated emf opposes the alteration in the current that generated it. According to the following formula, the self-induced emf's magnitude is proportional to the current's rate of change:

$$V = -L (dI/dt)$$

Where  $V$  is the self-induced emf,  $L$  is the coil's self-inductance, and  $(dI/dt)$  is the current's rate of change.

The coil's physical characteristics, such as the number of turns, coil shape, material surrounding the coil, and coil size, all affect its self-inductance. For instance, a coil with more turns would often have a higher self-inductance. Designing and using inductors is one of the significant uses of self-inductance. A coil of wire is used to create inductors, which are passive electrical parts that are used to store energy in magnetic fields. They are extensively utilized in several electrical circuits for functions including impedance matching, filtering, and energy storage. A coil's or circuit's capacity to resist changes in the current running through it by producing a self-induced emf is known as self-inductance. It is a crucial idea in electromagnetism and has real-world uses in inductors and different electrical systems[7]–[9].

**Mutual Inductance:** A key idea in electromagnetism is mutual inductance, which describes how two coils or circuits may affect one another's magnetic fields and create voltages in one another. When two coils are put near to one another, the shifting current in one coil causes an increase in voltage in the other coil. One coil creates a magnetic field around it as a current goes through it. The second coil is then connected to this shifting magnetic field, which, in accordance with Faraday's law of electromagnetic induction, induces a voltage in the second coil. The following equation determines the induced voltage in the second coil, which is proportional to the rate of current change in the first coil:



$$V_2 = -M (dI_1/dt)$$

Where  $V_2$  is the induced voltage in the second coil,  $dI_1/dt$  is the rate of change of current in the first coil, and  $M$  represents the mutual inductance between the two coils.

The number of turns in each coil, their relative orientation and separation, as well as the permeability of the medium between them, are all parameters that affect the mutual inductance, or  $M$ . It is usually expressed in henries (H) and measures the coupling between the two coils. In many different applications, notably in transformers, mutual inductance is crucial. Transformers are components that transfer electrical energy from one circuit to another by using mutual inductance. A voltage is induced in the secondary coil by the main coil when it is linked to a power source, which changes the magnetic field and allows electrical energy to be transferred. Other components and systems, including connected inductors, transformers, inductive proximity sensors, and some communication systems, all depend on mutual inductance. The capacity of two coils or circuits to affect one another's magnetic fields and produce voltages is referred to as mutual inductance. It is a key idea in electromagnetism, and transformers and other electrical and electronic devices use it in real life.

**Coefficient of Coupling:** In a transformer or other coupled inductor system, the coefficient of coupling is a crucial metric that describes the strength of magnetic coupling between two coils. It measures how closely one coil's magnetic field interacts with the turns of the other coil. "k" stands for the coefficient of coupling, which has a value between 0 and 1. The physical configuration of the coils and the relative positions of their magnetic fields have a significant impact on the coefficient of coupling. The coefficient of coupling is closer to 1, indicating a tight magnetic coupling, when the magnetic field lines of one coil travel through a sizeable part of the turns of the other coil. The coefficient of coupling is closer to zero, indicating a loose or weak coupling, on the other hand, if the magnetic field lines do not overlap many turns of the second coil. Let's use a transformer as an example to more clearly comprehend the coefficient of coupling. Two coils, a main coil and a secondary coil, are twisted around a common magnetic core to make a transformer. The secondary coil is linked to a load, while the primary coil is connected to an AC power supply. Energy transmission between the coils is made possible by the main coil's creation of a time-varying magnetic field that induces a voltage in the secondary coil. The following variables affect a transformer's coefficient of coupling,  $k$ :

**a.Geometric Alignment:** The coils' actual geometric alignment has a big impact on the coefficient of coupling. The magnetic flux produced by one coil is more likely to cross the turns of the other coil if they are concentrically coiled or share a magnetic core, which raises the coefficient of coupling.

**b.Mutual Inductance:** The coefficient of coupling is also influenced by the mutual inductance,  $M$ , between the coils. The capacity of one coil to cause a voltage in the other coil is referred to as mutual inductance. The mutual inductance and the coefficient of coupling are connected by the equation  $k = M/\sqrt{L_1 * L_2}$ , where  $L_1$  and  $L_2$  are the main and secondary coils' respective self-inductances.

**c.Magnetic Shielding:** By containing and focusing the magnetic flux, magnetic shielding material, such as a ferromagnetic core, can improve the coupling between the coils. A greater coefficient of coupling results from this.

**d.Separation Distance:** The coupling is impacted by the separation between the coils. The magnetic field lines that travel through the other coil get thinner as the distance grows, resulting in a reduced coefficient of coupling.

The performance and design of transformers are significantly influenced by the coefficient of coupling. In order to transmit energy efficiently and cut losses, power transformers should have a high coefficient of coupling. Additionally, it makes impedance matching between the primary and secondary circuits and voltage regulation possible. A low coefficient of coupling is preferred in applications that need for a high degree of isolation, such as some signal transformers, in order to reduce undesired coupling and electromagnetic interference. The coefficient of coupling, abbreviated "k," measures how strongly two coils are magnetically coupled. It is impacted by elements such the coils' physical configuration, shared inductance, magnetic shielding, and separation distance. Transformer design and operation depend heavily on the coefficient of coupling, which also affects energy transmission, voltage control, and circuit isolation in other coupled inductor systems.

**Inductances in Series and Parallel:**Based on how the circuit is configured, the total inductance of inductors linked in series or parallel may be determined. Let's examine the equations for determining the total inductance in both series and parallel arrangements.

**a.Inductors in Series:** Series-connected inductors have a total inductance ( $L_{total}$ ) that is the sum of their individual inductances ( $L_1, L_2, L_3,$ ):

$$L_{total} = L_1 + L_2 + L_3 + \dots$$

As more inductors are added in a series connection, the overall inductance rises. This is so because the magnetic fields produced by each inductor are added together to create the overall magnetic field produced by the series combination. The algebraic sum of the various inductances is, therefore, the overall inductance[10].

**b.Inductors in Parallel:** The reciprocal of the total inductance ( $1/L_{total}$ ) is equal to the sum of the reciprocals of the individual inductances ( $1/L_1 + 1/L_2 + 1/L_3 + \dots$ ) when inductors are linked in parallel.

$$1/L_{total} = 1/L_1 + 1/L_2 + 1/L_3 + \dots$$

We use the reciprocal of both sides of the equation to determine the total inductance:

$$L_{total} = 1 / (1/L_1 + 1/L_2 + 1/L_3 + \dots)$$

As more inductors are added to a parallel connection, the overall inductance drops. This is due to the fact that as the magnetic fields produced by the many inductors combine, a larger overall magnetic field and lower inductance are produced. It's vital to remember that while the voltage across each inductor is the same in parallel connections as well as series connections, the current flowing through each inductor is different. It's also important to note that in practice, the mutual inductance between inductors may come into play and alter the total inductance calculation when they contain magnetic cores or are physically adjacent to one another. The above-mentioned formulae, however, nevertheless hold true in basic series and parallel arrangements without mutual coupling. With the use of these formulae, we may more accurately evaluate and create inductors-based circuits by calculating the equivalent inductance when inductors are connected in series or parallel.

**Energy Stored in a Magnetic Field:** The equation: gives the amount of energy held in a magnetic field.

$$E = (1/2) L I^2$$

Where E stands for the magnetic field's stored energy, L for the coil's inductance, and I for the current moving through it.

This equation results from taking into account the effort put forward to create the magnetic field in the coil. A magnetic field is created around a coil as a current passes through it. Magnetic potential energy is a sort of energy that the magnetic field holds. The magnetic field's ability to retain energy is inversely related to the square of the current through the coil. The quantity of energy stored increases with increasing current. The inductance of the coil has an impact on the energy as well. The coil's capacity to store energy in its magnetic field is measured by inductance.

The fact that energy is stored symmetrically in the magnetic field during both the charging and discharging phases of the coil leads to the factor of (1/2) in the formula. A crucial factor in many electrical and electronic devices is the magnetic field's stored energy. For instance, the performance and efficiency of inductors used in power electronics are affected by the energy stored in the magnetic field. Electrical energy may be transferred from the main coil to the secondary coil in transformers thanks to the magnetic field's stored energy. For developing and evaluating circuits containing inductors as well as for assuring the effective and secure operation of these devices, it is essential to comprehend the energy stored in a magnetic field.

**AC Excitation in Magnetic Circuits:**The application of an alternating current (AC) signal to a magnetic circuit or a magnetic component, such as an inductor or a transformer, is referred to as AC excitation in magnetic circuits. It entails the creation of a magnetic field with time-varying properties that causes voltages and currents in the circuit parts. A time-varying magnetic field is produced when an AC signal is supplied to a magnetic circuit, such as an inductor or a transformer. This alternating magnetic field alters the magnetic characteristics of the circuit's components and induces voltages in neighbouring wires. Several parameters and theoretical ideas may be used to characterize the behaviour of the magnetic circuit under AC excitation:

**a. Inductive Reactance (XL):** The resistance to the flow of AC current brought on by a time-varying magnetic field is represented by an inductor or coil's inductive reactance. It is exactly proportional to both the coil's inductance and the frequency of the AC signal. The formula  $X_L = 2\pi fL$ , where f is the frequency and L is the inductance, may be used to get the inductive reactance.

**b. Magnetic Permeability ( $\mu$ ):** How quickly magnetic flux is created depends on the material's magnetic permeability within the magnetic circuit. It has an impact on the inductance and the circuit's capacity to conduct magnetic flux. Some substances, such as ferromagnetic substances, have a higher magnetic permeability, which makes them better suited for use in magnetic circuits.

**c. Eddy Currents:**A changing magnetic field may produce circulating currents called eddy currents as it moves through a conducting material, like the core of a transformer. Eddy currents can increase heating and power losses in the magnetic circuit, which lowers the system's

efficiency. Cores that are laminated or are insulated are frequently utilized to reduce eddy currents.

**d.Magnetic Hysteresis:** A magnetic material can exhibit magnetic hysteresis, which is the phenomenon where some magnetism persists even after the excitation field has been withdrawn. It causes energy losses and may change the circuit components' magnetic characteristics.

In many applications, AC excitation in magnetic circuits is essential. Transformers, for instance, use AC excitation to induce a shifting magnetic field in order to transmit electrical energy from one coil to another. The inductive reactance and impedance of inductors and inductive components used in AC circuits are impacted by AC excitation. For the design, analysis, and optimization of electrical and electronic systems incorporating inductors, transformers, magnetic cores, and other magnetic components, it is crucial to comprehend the behavior of magnetic circuits under AC stimulation. It aids engineers in achieving the necessary performance characteristics of these systems by minimizing losses, ensuring effective power transmission, and ensuring efficiency.

**Eddy Current Loss:**The energy loss that takes place in conductive materials when they are exposed to a shifting magnetic field is referred to as eddy current loss. Eddy currents, or circular electric currents created inside the material, are what give rise to this phenomenon. Understanding eddy current loss's principles and minimizing its effects are essential for effective and dependable operation since it plays a vital role in many electrical devices and systems. The idea of eddy current loss will be thoroughly examined in this article, along with its causes, consequences, and mitigation strategies. Electrical current loops called eddy currents move about in conductive materials like metals in response to a shifting magnetic field. A magnetic field's interaction with a conductor causes the material to experience voltage and electric currents. The conductivity of the material, the strength of the magnetic field, the frequency of the magnetic field, and the geometry of the material are some of the variables that affect the size of the induced currents. One of the most obvious effects of these eddy currents is the loss of energy in the form of heat. Resistance that is encountered by the eddy currents as they go through the conductive material results in energy loss in the form of heat. Eddy current loss is the term used to describe this energy loss.

The resistivity of the material, its thickness, the frequency of the magnetic field, and the size and form of the conductive component are some examples of the variables that affect the amount of the loss. Different electrical systems and gadgets may suffer negative impacts from eddy current loss. Because the wasted energy does not help the equipment perform as it is intended to, overall efficiency suffers. The temperature rise brought on by this energy loss can have an impact on the functionality and longevity of components. In severe circumstances, excessive eddy current loss may result in component failure, overheating, and decreased efficiency. Many methods and tactics may be used to lessen the effects of eddy current loss. The lamination of conductive materials is one way that is frequently employed. The route of the eddy currents is disrupted by separating the material into thin layers or laminations, lowering the overall size of the currents and minimizing energy loss. Construction of transformers, electric motors, and generators frequently employs this technology. Utilizing materials with poor electrical conductivity is another method for lowering eddy current loss. Lower energy dissipation is achieved by choosing materials with lower conductivity, which also reduces the size of the eddy currents.

Eddy currents can also be suppressed by using magnetic materials with high resistance. Managing the magnetic field's frequency is another effective method for reducing eddy current loss. Due to the faster rates of current induction and circulation, higher frequencies cause a rise in energy dissipation. The amplitude of the eddy currents can be reduced, resulting in a reduction in the related energy loss, by lowering the frequency or employing alternating magnetic fields. Eddy current loss may occasionally be used for particular purposes. Eddy currents, for instance, are used in induction heating to heat conductive materials. Eddy currents are produced by introducing high-frequency alternating magnetic fields, which causes localized heating. Applications for induction heating include metal hardening, welding, and kitchen appliances. Eddy current loss is an important occurrence in conductive materials exposed to shifting magnetic fields, to sum up. It affects the effectiveness and performance of electrical systems and devices by causing energy to be lost as heat. Designing and running effective systems requires an understanding of the factors that contribute to eddy current loss. Eddy current loss may be reduced and system performance can be increased by using strategies including laminations, material selection, frequency control, and eddy current use for particular applications. Eddy currents result in energy losses in the form of heat and power dissipation. The following variables affect the size of the eddy current loss:

**a. Material Conductivity:** The amplitude of the eddy currents increases with material conductivity, which also causes eddy current losses to increase. Eddy current losses are negligible in materials with limited electrical conductivity, such as insulators.

**b. Magnetic Field Strength:** The magnitude of the generated eddy currents increases with the strength of the magnetic field, which increases eddy current losses.

**c. Frequency of the Magnetic Field:** Eddy current losses are directly inversely correlated with the frequency of the changing magnetic field. Eddy currents and losses grow at increasing frequency.

**d. Thickness of the Material:** Conductive materials that are thicker provide more eddy current flow resistance, reducing losses. The material can be thinned to reduce eddy current losses.

Several methods are used to reduce eddy current losses:

**a. Laminated Cores:** The core of transformers and other magnetic devices is frequently composed of thin, electrically isolated magnetic laminations or sheets. By limiting their course and lowering total eddy current losses, this layered architecture serves to reduce the production of significant eddy currents.

**b. Magnetic Shielding:** By containing the magnetic fields and avoiding their interaction with neighboring conductive materials, magnetic shielding materials, such as mu-metal, can minimize eddy current losses.

**c. Soft Magnetic Materials:** Soft magnetic materials can assist reduce eddy current losses while keeping the appropriate magnetic characteristics. These materials have high magnetic permeability and low electrical conductivity.

The design of transformers, inductors, motors, and other electrical equipment must take eddy current losses into account. To increase energy efficiency, lessen heat generation, and maximize system performance, engineers work to minimize these losses.



## CONCLUSION

A fundamental idea in physics, electromagnetic induction is important for many real-world applications. Engineers and scientists have created a variety of tools and technologies that take use of this phenomena by comprehending the connection between a shifting magnetic field and the induction of an electric current in a conductor. A few examples of how electromagnetic induction is used in daily life to provide us with electricity, effective energy transmission, and other necessary functions are generators, transformers, and induction coils. Our knowledge of the natural world continues to grow as a result of ongoing study on electromagnetic induction, which also advances the creation of cutting-edge technology.

## REFERENCES:

- [1] T. Imura and Y. Hori, "Unified Theory of Electromagnetic Induction and Magnetic Resonant Coupling," *Electr. Eng. Japan (English Transl. Denki Gakkai Ronbunshi)*, 2017, doi: 10.1002/ej.22953.
- [2] T. Imura and Y. Hori, "Unified theory of electromagnetic induction and magnetic resonant coupling," *IEEJ Trans. Ind. Appl.*, 2015, doi: 10.1541/ieejias.135.697.
- [3] A. D. Chave, "On the theory of electromagnetic induction in the earth by ocean currents.," *J. Geophys. Res.*, 1983, doi: 10.1029/jb088ib04p03531.
- [4] J. T. Weaver, "The General Theory of Electromagnetic Induction in a Conducting Half-Space," *Geophys. J. R. Astron. Soc.*, 1971, doi: 10.1111/j.1365-246X.1971.tb03584.x.
- [5] A. P. Sutton and T. N. Todorov, "Theory of electroplasticity based on electromagnetic induction," *Phys. Rev. Mater.*, 2021, doi: 10.1103/PhysRevMaterials.5.113605.
- [6] S. P. Hargunani, "Teaching of Faraday's and Lenz's theory of electromagnetic induction using java based Faraday's lab simulations.," *Latin-American J. Phys. Educ.*, 2010.
- [7] J. Guisasola, J. M. Almudí, and K. Zuza, "Diffcultades de los estudiantes universitarios en el aprendizaje de la inducción electromagnética," *Rev. Bras. Ensino Fis.*, 2010, doi: 10.1590/S1806-11172010000100011.
- [8] I. C. Rae, "A theory of electromagnetic induction in layered media: Linear motor modeling," *Q. Appl. Math.*, 1983, doi: 10.1090/qam/99621.
- [9] K. Zuza, J. M. Almudí, A. Leniz, and J. Guisasola, "Addressing students' difficulties with Faraday's law: A guided problem solving approach," *Phys. Rev. Spec. Top. - Phys. Educ. Res.*, 2014, doi: 10.1103/PhysRevSTPER.10.010122.
- [10] P. M. Binder and J. F. Guerrero, "Theory of grazing electromagnetic induction," *Eur. J. Phys.*, 2016, doi: 10.1088/0143-0807/37/6/065207.

## TRANSFORMER THEORY: PRINCIPLE AND OPERATIONS

**Mr. Vesapogu Joshi\***

\*Associate Professor,  
Department of Electrical And Electronics Engineering,  
Presidency University, Bangalore, INDIA  
Email Id-joshimanohar@presidencyuniversity.in

---

### ABSTRACT:

*A transformer is a device that transfers electric energy from one alternating-current circuit to another, either raising or decreasing the voltage. An essential part of power networks that makes for effective transmission and distribution of electrical energy is the transformer. It is essential for impedance matching, isolation, and voltage transformation. The fundamental operating concept of a transformer is the phenomena of mutual induction between two windings connected by a shared magnetic flux. The diagram on the right depicts the most basic form of a transformer. A transformer is made up of two inductive coils: main and secondary windings. An overview of the Transformer's functionality, essential parts, and importance in power systems are given in this chapter.*

**KEYWORDS:** Auto-Transformer, Importance, Ideal Transformer, Real Transformer, Transformer Losses.

---

### INTRODUCTION

In order to efficiently transmit and distribute electrical energy, transformers are a crucial part of power networks. It is essential for impedance matching, isolation, and voltage transformation. This page gives a thorough introduction to transformers, including their main functions, types, and uses in electrical power networks. The electromagnetic induction principle, which is based on Faraday's law of electromagnetic induction, governs how a transformer works. This rule states that an altering magnetic field causes a conductor to develop a voltage. A common magnetic core is encircled by two or more windings, sometimes referred to as coils, in a transformer. The load is linked to the secondary winding, which is separate from the main winding's connection to the input voltage source. Alternating current (AC) is used to power the primary winding, which produces a fluctuating magnetic field.

Through electromagnetic induction, this magnetic field causes a voltage to be induced in the secondary winding. The transformer's voltage transformation ratio is determined by the turn's ratio between the primary and secondary windings. Transformers may step up or step down the voltage by varying the number of turns in each winding. Transformers have a number of significant benefits for power systems. By increasing the voltage at the producing station and lowering transmission losses, they first enable effective long-distance power transmission. Before being distributed to end consumers, the voltage is stepped down at the destination. This voltage transition lowers current levels, reducing resistive transmission losses. The electrical isolation between the primary and secondary windings is another benefit of transformers. As it restricts the flow of current between various components of the power system, this isolation

guarantees the safety of the machinery and the employees. Additionally, it reduces the risk of electric shock and safeguards against electrical problems. Additionally, transformers are essential for impedance matching. The resistance to the passage of alternating current in a circuit is known as impedance.

It is possible to match the impedance between various parts of the power system, facilitating effective power transmission, by properly designed transformers. By ensuring that the load receives the maximum amount of power from the source, the total system performance is optimized. Based on their uses and designs, transformers come in a variety of different varieties. For voltage transformation in transmission and distribution networks, power transformers are employed[1]–[3]. To scale down the voltage for distribution to end customers, distribution transformers are used. Specialized transformers called autotransformers have a common winding on both the main and secondary sides, allowing for a more compact construction. The instrument transformer is an additional kind that is employed for measurement and protection. Voltage transformers (VTs) step down high voltages for measurement whereas current transformers (CTs) step down large currents to a safe and detectable level. Transformers are also essential in systems that use renewable energy.

They make it easier to incorporate renewable energy sources like solar and wind into the current electrical infrastructure. They make it possible to control voltage, enhance the quality of the electricity, and link renewable energy sources to the grid. To sum up, transformers are crucial parts of electricity networks. Electrical isolation, effective voltage transformation, and impedance matching are all made possible by them. The effective transmission and distribution of electrical energy is ensured by their capacity to increase or decrease voltages. Power generation, transmission, and distribution networks, as well as the incorporation of renewable energy sources, all rely heavily on transformers. The performance, dependability, and efficiency of power systems are always being improved through transformer design and technology, ensuring a dependable and sustainable supply of electrical energy.

**Working Principle of Transformer:** The electromagnetic induction phenomena serves as the foundation for the operation of a transformer in a power system. A magnetic core and primary and secondary windings are its two main working parts. A shifting magnetic field develops around the primary winding when an alternating current (AC) passes through it. Through electromagnetic induction, the secondary winding generates a voltage when the magnetic field changes. The secondary winding is linked to the load, which makes use of the voltage transformation. The following stages can be used to summarize the main working principle:

**a.Application for AC Voltage:** The transformer's primary winding is linked to an AC voltage source, such as a power grid or generator. Typically, a high voltage level of AC voltage is provided to the primary winding, making it appropriate for long-distance transmission.

**b.Magnetic Field Generation:** Alternating current is created in the winding as a result of the AC voltage flowing through the primary winding. A fluctuating magnetic field is produced around the primary winding by this alternating current. With current strength and direction, the magnetic field's intensity rises and falls.

**c.Magnetic Field Induction:** Through electromagnetic induction, the shifting magnetic field causes a voltage to be induced in the secondary winding. The rate of change of the magnetic field and the number of turns in the secondary winding both affect the induced voltage in the winding.

**d. Voltage Transformation:** The transformer's voltage transformation ratio is based on the number of turns in the primary and secondary windings. The transformer may step up or step down the voltage by varying the number of turns in each winding. The transformer raises the voltage, for instance, if the secondary winding has more turns than the main winding. The transformer lowers the voltage if the secondary winding has fewer turns.

**e. Utilization of the Load:** The secondary winding's converted voltage is then linked to the load, such as a home, business, or industrial electrical system. The converted voltage is used by the load for a variety of purposes, including lights, motors, and electrical equipment.

It's vital to remember that because induction requires a changing magnetic field, transformers can only function effectively with alternating current (AC). A conventional transformer cannot directly transform direct current (DC). However, before being fed into a transformer for voltage change, DC can be transformed into AC using electronics like as inverters. To sum up, electromagnetic induction is the basis for the way a transformer in a power system functions. When an AC voltage is delivered, it results in the formation of a fluctuating magnetic field across the primary winding. The secondary winding experiences a voltage as a result of the fluctuating magnetic field, which may then be transformed and used by the load. Transformers are crucial components of power networks because they allow for the effective transmission, distribution, and use of electrical energy.

## DISCUSSION

**Importance of Transformer:** The following justifications explain why transformers are so crucial to electricity systems:

**a. Voltage Transformation:** Transformers make it possible to transform voltage levels effectively. To reduce transmission losses, power generating often takes place at a higher voltage. For long-distance transmission, transformers increase the voltage while lowering the current and, as a result, the resistive losses. Transformers reduce the voltage to an appropriate level for distribution and use at the final location.

**b. Efficient Power Transmission:** Power transmission across long distances with the least number of losses is made possible by transformers by stepping up the voltage. Lower current levels improve the overall efficiency of the power system by reducing resistive losses in transmission lines.

**c. Electrical Isolation:** Transformers may isolate the electrical current flowing between the primary and secondary windings. By stopping the passage of electricity between separate components of the power system, this isolation assures the security of people and equipment. It reduces the chance of electric shock and safeguards against electrical problems.

**d. Impedance Matching:** Impedance matching is made possible by transformers between various parts of the power system. The resistance to the passage of alternating current in a circuit is known as impedance. It is feasible to match the impedance and maximize power transmission between coupled systems by properly constructing transformers. This guarantees maximum power transfer from the source to the load and enhances system performance as a whole.

**e. Power Quality Improvement:** Transformers assist in the enhancement of power quality in electrical systems. They aid in controlling voltage levels, guaranteeing a steady and trustworthy

power supply. Transformers reduce voltage sags, harmonics, and fluctuations, protecting delicate equipment from potential injury.

**f. Integration of Renewable Energy Sources:** Transformers are essential for the integration of renewable energy sources into the current electrical system, including solar and wind energy. They make it possible to control voltage, rectify power factor, and synchronize renewable energy installations with the grid. Transformers make it easier for variable renewable energy production to be smoothly integrated into the dependable power system, maintaining the stability of the grid and a steady supply of electricity.

**g. Load Balancing:** Transformers help in load balance within the electrical system. They contribute to the upkeep of a balanced load across the network by properly distributing electricity across various transformers. By doing this, individual components aren't overloaded, and the use of the resources that are available is maximized.

**h. Flexibility and Scalability:** Transformers enable power systems to be flexible and scalable. They may be created to satisfy different voltage specifications and adapt to shifting load demands. To meet the changing demands of the power system, transformers may be readily added or removed.

All things considered, transformers are essential parts of power systems because they allow for effective voltage transformation, provide electrical isolation, and enable impedance matching. Their significance lies in the effective transmission of electricity, the enhancement of power quality, and the incorporation of renewable energy sources. Transformers are essential for guaranteeing dependable and sustainable electrical energy generation, transmission, and distribution because of their wide range of uses and advantages.

**Construction of a Transformer:** The following essential elements are commonly used in the construction of transformers:

- 1. Core:** Materials with high permeability, such as laminated silicon steel, are used to create the core. It offers the magnetic flux produced by the windings a low-reluctance channel. Eddy current losses in the core are minimized by the laminated construction.
- 2. Windings:** Insulated copper conductors are coiled around the core to form the main and secondary windings. The voltage transformation ratio is dependent on the number of turns in each winding. To avoid electrical short circuits and provide correct electrical isolation, the windings are insulated.
- 3. Insulation:** To insulate the windings and create electrical isolation, insulating materials like paper, varnish, or synthetic materials are utilized. Insulation is essential for safeguarding the transformer's safety and dependability by avoiding arcing and short circuits.
- 4. Tanks and Enclosures:** Transformers are contained in tanks or enclosures that offer insulation and mechanical protection. For the purpose of dissipating heat produced during operation, the tank is normally built of steel and filled with insulating oil.
- 5. Cooling Systems:** Transformers need cooling systems to remove heat produced by losses in the core and windings. Common cooling techniques include forced air or liquid cooling, which uses fans or coolants to increase heat transmission, and natural convection, where the heat is dispersed via the tank surface.



### Practical Points to Consider

- 1. Efficiency:** To reduce energy losses, transformers should be constructed and operated with high efficiency. Transformer efficiency as a whole is influenced by effective cooling systems, ideal winding designs, and efficient core materials.
- 2. Load Capacity:** Transformers should be adequately sized to accommodate the anticipated load demand. During transformer selection and design, factors including maximum load current, load variations, and future load increase must be taken into account.
- 3. Voltage regulation:** Under a variety of load scenarios, transformers should produce a steady voltage. Effective voltage regulation is made possible by careful design considerations such as the turns ratio, core size, and regulation methods.
- 4. Noise reduction:** Due to magnetostriction and vibration, transformers can generate audible noise. Correct core and winding designs, mechanical isolation, and vibration dampening techniques can all be used to reduce noise levels.
- 5. Life of Insulation:** A transformer's insulation system should have a lengthy service life. The dependability and endurance of the transformer are enhanced by using high-quality insulation materials and performing routine maintenance procedures including testing and monitoring insulation resistance.
- 6. Safety:** In order to safeguard people and property, transformers should be properly built and installed. The use of protective equipment, correct insulation, suitable grounding, and compliance with applicable safety standards and regulations are all safety factors.
- 7. Impact on the environment:** Transformer design should take into account environmental factors, such as the selection of an ecologically benign and non-toxic insulating oil. Oil leakage should be minimized, and soil and water pollution should be avoided.
- 8. Maintenance and Monitoring:** Regular maintenance and monitoring are crucial for the performance and lifetime of transformers. Visual inspections, oil analysis, and insulation testing all aid in finding any possible problems and enable prompt maintenance or component replacement.

The important parts including the core, windings, insulation, tanks, and cooling systems are used in the building of transformers. Efficiency, load capacity, voltage regulation, noise reduction, insulating life, safety precautions, environmental effect, and maintenance are practical issues. These factors may be taken into account while designing and operating transformers, resulting in a dependable and effective operation of the electrical system.

**Transformer on No-Load:** When a transformer is in no-load mode, the secondary winding is open and not conducting any electricity. Although the secondary side of the transformer is not currently loaded, it is linked to the power source. Let's see what occurs in a transformer when there is no load:

**a.Primary Side:** The primary winding is connected to the AC voltage source on the transformer's primary side. The transformer's core develops a magnetic field as a result of this voltage. The parameters of the core material and the applied voltage have an impact on the magnetic field's strength[4]–[6].

**b.Magnetic Flux:** The magnetic flux is brought on by the magnetic field produced in the core. Both the transformer's main and secondary windings are connected to this flux. However, no voltage is produced in the secondary winding since no current is flowing through it.

**c.Core Losses:** The transformer still sustains core losses even in the absence of a connected load. Hysteresis loss and eddy current loss are the two halves of core losses. Eddy current loss is brought on by circulation currents created in the core, whereas hysteresis loss is the energy lost because to the core material's reversal of magnetization. The overall effectiveness of the transformer may be impacted by these losses, which appear as heat.

**d.No Output Voltage:** No output voltage is produced because there is no load attached to the secondary side, which prevents any current from flowing through the winding and creating any output voltage. The secondary winding's voltage stays at zero.

**e.Magnetizing Current:** Due to the core's magnetism, a tiny current known as the "magnetizing current" flows on the main side. While this current generates the magnetic field required for induction, it has no impact on how much power is transferred. The transformer's no-load current is represented by the magnetizing current, which is normally a small portion of the rated current.

**f.Impedance and Regulation:** A transformer's performance when there is no load is also impacted by its impedance, which is symbolized by its magnetizing reactance. The voltage regulation, or the transformer's capacity to maintain a comparatively steady output voltage under various load situations, is determined by reactance. A transformer with a low impedance will have superior voltage management when there is no load.

**g.No Secondary Side Effects:** Because there is no load attached to the secondary side, the winding is not conducting any current. Therefore, there are no voltage dips, power losses, or any secondary side load-related impacts.

The main winding of a transformer is activated and a magnetic field is created in the core while it is not in use. However, because there is no load attached, no voltage is induced in the secondary winding. There are core losses and a tiny magnetizing current experienced by the transformer, but the secondary side does not experience any output voltage or current. No-load situations have an impact on the transformer's overall performance and losses, thus they must be taken into account when designing and calculating a transformer's efficiency.

**Ideal Transformer:**The concept of an ideal transformer is a theoretical tool for streamlining transformer calculations and analysis. It makes some ideal assumptions that might not apply to real-world transformers but nonetheless serve as a valuable model for comprehending their behavior. The main presumptions and qualities of a perfect transformer are as follows:

**a.No Losses:** There aren't any energy losses in a perfect transformer. This indicates that there are no losses caused by resistance, hysteresis, or eddy currents in the windings or core and that the whole input power is properly transmitted to the output. The efficiency of a perfect transformer is therefore thought to be 100%.

**b.Perfect Magnetic Coupling:** A perfect magnetic coupling between the main and secondary windings is necessary for a flawless transformer. This results in a flawless transmission of energy since the main winding's whole magnetic flux is coupled to the secondary winding.

**c.No Leakage Inductance:** In a perfect transformer, leakage inductance, which is a measure of the magnetic flux that does not connect with the secondary winding, is supposed to be zero. Calculations are made easier and the secondary winding is guaranteed to get all of the flux thanks to this presumption.

**d.No Magnetizing Current:** In a perfect transformer, the core doesn't need to be magnetized by any current. In the ideal scenario, it is assumed that the magnetizing current, which is required to create the magnetic field in a real transformer, is zero.

**e.Ideal Current and Voltage Ratios:** The turns ratio of the windings alone determines the voltage transformation ratio of an ideal transformer. While the current ratio is inversely proportional to the turn's ratio, the main and secondary voltages are directly proportional to the turn's ratio. Regardless of the load linked to the secondary side, this supposition is valid.

**f.No Phase Shift:** The main and secondary voltages of an ideal transformer are assumed to be in phase alignment. This suggests that the voltage waveforms have a constant frequency and are completely in phase throughout the transformer.

Even though an ideal transformer offers a streamlined analysis model, it's crucial to remember that real-world transformers don't always match these ideal specifications. Real transformers experience losses as a result of core losses, resistive heating, and other issues. They also have some phase shift, limited magnetizing current, and leakage inductance. Despite these departures from the ideal, the idea of an ideal transformer is still a helpful guide for comprehending the underlying ideas behind transformer functioning, figuring out the correlations between voltage and current, and streamlining transformer circuit analysis.

**Real Transformer and their Equivalent circuit:**The fact that a real transformer has a number of non-ideal traits and losses sets it apart from an ideal transformer. A typical method for simulating a transformer's behavior is to utilize an analogous circuit model. This model is made out of a variety of ideal circuit components that simulate the behavior of the transformer in real life. The main elements of a typical equivalent circuit model for an actual transformer are as follows:

- 1. Primary and Secondary Windings:** Inductors are used to represent the transformer's primary and secondary windings. These inductors are responsible for the windings' leakage inductance and magnetizing inductance. The leakage inductance is the fraction of the magnetic flux that does not connect with the secondary winding, whereas the magnetizing inductance is in charge of creating the magnetic field.
- 2. Resistances:** In the equivalent circuit model, the resistances take the copper losses in the windings into account. Heat is lost as a result of copper losses that are brought on by the conductors in the windings.
- 3. Magnetizing Branch:** The magnetizing branch has a parallel configuration of a resistor and an ideal inductor. The resistor compensates for the core losses, such as hysteresis and eddy current losses, whereas the inductor reflects the core's magnetizing inductance.
- 4. Load Branch:** On the transformer's secondary side, the load branch symbolizes the connected load's impedance. It also has a load impedance, which, depending on the kind of load, may be a mix of resistance, inductance, and capacitance.

**5. Mutual Inductance:** The connection between the primary and secondary windings is represented by the mutual inductance. It is in charge of transferring energy within the transformer as well as magnetic flux from the primary to the secondary winding.

These components can be added to the equivalent circuit model in order to more correctly study the behavior of a genuine transformer. The model may be used to compute variables including efficiency, power losses, and voltage control. It's vital to remember that measurements and tests on the real transformer shown in Figure 1 can be used to ascertain the values of the equivalent circuit characteristics. The equivalent circuit model is often an approximation that gives adequate accuracy under ordinary operating settings because the parameters may vary with frequency, temperature, and operating conditions. For the analysis and design of transformer systems, the equivalent circuit model is a useful tool that enables engineers to comprehend and forecast the behavior of actual transformers in real-world applications.

**Transformer losses:** Diverse losses of different kinds occur while transformers are in operation. These losses have an impact on the transformer's functionality and lower overall efficiency. The following are the primary categories of losses in a transformer:

### Copper Losses

**a. Ohmic Losses or  $I^2R$  Losses:** Ohmic losses, also known as  $I^2R$  losses, happen in the main and secondary windings as a result of the conductors' resistance. Heat is produced as current passes through windings in proportion to the square of the current and the winding resistance. By employing conductors with low resistivity and greater cross-sectional areas, these losses may be reduced to a minimum.

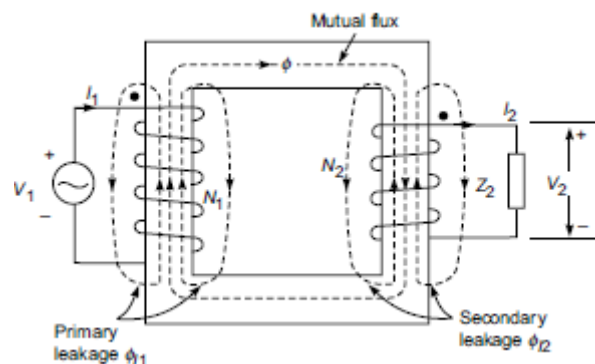

**Figure 1: Representing the Real Transformer [EEE Guide].**

**b. Eddy Current Losses:** The fluctuating magnetic field causes eddy currents to occur in the transformer's conducting core material. Energy losses result from resistive heating brought on by these circulating currents in the core material. Transformer cores are often built from laminated sheets to minimize eddy current channels and employ materials with poor electrical conductivity in order to minimize these losses.

### 2. Core Losses

**a. Hysteresis Losses:** Hysteresis losses happen as the alternating current causes the magnetic field to repeatedly magnetize and demagnetize the core material. Heat is produced in the core material as a result of the energy lost during these magnetic reversals. In order to minimize these

losses, laminated silicon steel and other materials with low hysteresis loss are frequently used to create transformer cores[7]–[9].

**b. Eddy Current Losses:** As was already mentioned, resistive heating is brought on by eddy currents induced in the core material. Utilizing laminated cores, which restrict eddy current circulation and lessen the related energy losses, can help to mitigate these losses.

### 3. Stray Losses:

**a. Leakage Inductance Losses:** This category of stray losses refers to the fraction of the magnetic flux that does not connect with the secondary winding. Energy is lost as a result of electromagnetic interactions and heating as a result of this flux leakage. These losses can be decreased by designing transformers with little leakage inductance.

**b. Stray Magnetic Field Losses:** Eddy currents and losses in neighboring conductive materials can be caused by stray magnetic fields produced by transformers. These stray losses can be reduced by shielding methods and careful design.

### 4. Dielectric Losses

**a. Insulation Losses:** The electric field stress and dielectric losses cause energy losses in the insulating materials used in transformers. The insulation between the windings and between the windings and the core is where these losses happen most frequently. These losses can be reduced by using high-quality insulating materials and appropriate design methods.

To maximize efficiency and reduce energy waste, it is crucial to take these losses into account when designing and operating transformers. Through careful core material selection, winding design, insulation systems, and cooling techniques, losses are attempted to be minimized. Transformers often balance the trade-offs between losses, cost, and other performance criteria to operate at high efficiency under normal operating circumstances.

**Efficiency and Voltage Regulation:** Efficiency and voltage control are two crucial transformer performance factors. Let's examine each of them in detail:

**Efficiency:** The ratio of the output power to the input power, stated as a percentage, is referred to as the transformer's efficiency. It shows how well a transformer transfers electricity from the main side to the secondary side. More efficiency translates to improved power use and fewer energy loss. Transformer efficiency is affected by a number of variables, including as copper losses, core losses, and load circumstances.

1. **Copper Losses:**  $I^2R$  losses, commonly referred to as copper losses, are brought on by the conductors used for winding's resistance. With the square of the current passing through the windings, these losses rise. By combining bigger conductor diameters with low resistivity materials, copper losses may be kept to a minimum [10].
2. **Core Losses:** Hysteresis losses and eddy current losses are the two types of core losses. Eddy current losses originate from circulation currents created in the core, whereas hysteresis losses are caused by the magnetic reversal in the core material. Core losses can be decreased by using materials with low hysteresis and eddy current losses, like laminated silicon steel.
3. **Conditions Under Load:** The load attached to the secondary side of a transformer affects its efficiency. In general, near-rated loads result in improved efficiency for transformers. The



efficiency may decline due to fixed losses at smaller loads, and it may decline due to rising copper losses at heavier loads.

**Voltage Regulation:** Voltage regulation describes a transformer's capacity to keep the secondary voltage essentially constant despite variations in the load current. It expresses as a percentage the voltage decrease from the no-load situation to the full-load condition. Winding resistance, leakage reactance, and magnetizing reactance are a few examples of the variables that affect voltage control.

- 1. Resistance of the Windings:** A voltage drop brought on by the resistance of the windings has an impact on the secondary voltage control. Better voltage control is the result of lower winding resistances.
- 2. Leakage Reactance:** The magnetic flux that does not connect to the secondary winding is represented by leakage reactance. Reactance generates a voltage decrease as a result, particularly when there is a load. Improved voltage control results from lower leakage reactance.
- 3. Magnetizing Reactance:** The magnetizing reactance controls the amount of magnetizing current necessary to create the magnetic field within the transformer. Larger voltage dips and worse voltage regulation may be the results of higher magnetizing reactance.

For various loading scenarios, transformer manufacturers frequently provide the efficiency and voltage regulation parameters. These factors must be taken into account in order to maximize the performance, economy, and dependability of transformer systems. Designers strive to balance efficiency and voltage control while taking into account the needs of the individual application, the nature of the load, and the available budget.

**Excitation Phenomenon in Transformer:** In transformers, the term "excitation phenomenon" describes the magnetic behavior of the transformer's core under an alternating current (AC) voltage. The magnetic field necessary for energy transfer between the primary and secondary windings must be created and maintained. Let's look more closely at the excitation phenomenon:

- a. Magnetization of the Core:** A transformer's primary winding experiences alternating current flow when an AC voltage is supplied to it. In the core, this alternating current generates an alternating magnetic field. The secondary winding experiences an equivalent alternating voltage as a result of the magnetic field.
- b. Core Saturation:** A transformer's core material has a saturation point, or the strongest magnetic field that it can withstand before losing its ability to behave magnetically linearly. The core achieves saturation when the magnetic field intensity rises, and the increase in magnetic flux becomes disproportionate to the rise in applied voltage. The magnetization curve of the transformer becomes nonlinear due to saturation.
- c. Effect of Hysteresis:** Another aspect of the excitation phenomena is hysteresis, which is the lag or delay in the magnetization and demagnetization of the core material as a result of the alternating current cycles. The magnetic characteristics of the core material cause the hysteresis effect, which results in energy losses in the form of heat.
- d. Core Losses:** In transformers, core losses are a result of the excitation phenomena. Hysteresis losses and eddy current losses are two examples of these losses. Due to the energy

lost during the core material's repeated cycles of magnetization and demagnetization, hysteresis losses happen. Circulating currents that are induced in the core material as a result of the shifting magnetic field cause eddy current losses.

- e. **No-Load Current:** To create and sustain the magnetic field, a little current known as the magnetizing current passes through the primary winding while there isn't a load on the secondary winding. The sufficient magnetic flux must be created in the core by the magnetizing current in order for power to be delivered to the load.
- f. **Voltage Regulation:** The excitation phenomena affects transformers' ability to regulate voltage. The capacity of the transformer to maintain a comparatively constant secondary voltage as the load changes is influenced by the magnetic behavior of the core, particularly its saturation characteristics and hysteresis impact. Under certain load conditions, nonlinear magnetization properties might cause problems with voltage control.

Transformer design takes into account the choice of core material, core shape, and selection of suitable operating points in order to reduce the consequences of the excitation phenomena. Eddy current losses and hysteresis losses are frequently decreased by using laminated silicon steel cores. Effective design and optimization methods reduce core losses, increase voltage control, and improve the transformer's overall performance.

**Auto-Transformer:**Electrical transformers known as autotransformers contain a single winding with many taps that enable the achievement of various voltage ratios. Autotransformers are smaller and lighter than traditional transformers because they employ a single winding for both the primary and secondary circuits. A section of the winding serves as the primary and secondary windings in an autotransformer. The common winding or common tap, which is connected to a power supply, is a collective piece of this shared winding. The primary winding and secondary winding, which make up the remaining portions of the winding, are attached to the load. In comparison to traditional transformers, autotransformers provide a number of benefits. First, because of the shared winding architecture, they are lighter and more compact, making them appropriate for applications with limited space. In addition, autotransformers are more effective than traditional transformers since they consume less wire and have reduced copper losses. Voltage control is one of autotransformers' primary uses. Autotransformers may provide a variety of output voltages by tapping the same winding at various locations.

They are frequently used in power distribution systems to step up or down voltages, enabling effective voltage regulation and control. Electrical devices like voltage regulators and variable-speed motor drives also employ autotransformers. Autotransformers do have certain restrictions, though. The input and output voltages are directly connected since the main and secondary windings are not electrically separated. As a result, any issue or disruption on the primary side might affect the secondary side. As a result, in situations where electrical isolation is essential, isolation transformers are recommended. Autotransformers offer a convenient and effective method of regulating voltage in power systems. They have advantages over traditional transformers, including smaller size, lighter weight, and lower copper losses. Their usage is constrained in applications needing electrical isolation due to the common winding construction.

**Variable Frequency Transformer:**An electrical transformer known as a variable frequency transformer (VFT) allows electrical power to be converted between various voltage levels and frequencies. It is typically employed in situations when it is necessary to transmit power across

systems that operate at several frequencies or to connect renewable energy sources to the electrical grid. VFTs allow for the modification of both the input and output frequencies, in contrast to conventional transformers, which are made for a set frequency (such as 50 Hz or 60 Hz). They do this by embedding converters and inverters, among other power electronics, within the transformer's construction. The primary and secondary windings as well as the power electronics circuits are the main parts of a VFT. The management and conversion of electrical power at various frequencies is made possible by the power electronics. The VFT can successfully vary the output frequency while retaining the correct voltage levels by modifying the switching frequency and modulation strategies. The following are some benefits of employing VFTs:

- a. **Frequency Conversion:** VFTs enable the conversion of power between several frequency standards, making it possible to integrate a variety of power sources or to connect power systems that operate at various frequencies.
- b. **Voltage** VFTs have the ability to control output voltage levels, balancing out voltage swings and guaranteeing steady power supply.
- c. **System Regulation:**Integration of Renewable Energy: VFTs are essential for incorporating renewable energy sources like solar or wind power into the current electrical system. They facilitate effective power transmission by converting these sources' variable frequency outputs to the grid's frequency.
- d. **Power Quality Improvement:** By offering capabilities for voltage control and harmonic filtering, VFTs help reduce problems with power quality.

VFTs have various drawbacks and difficulties despite their advantages. Because power electronics are incorporated, they may cause extra losses, which may reduce the efficiency of the entire system. In comparison to conventional transformers, VFTs are more expensive and complex due to the complexity of control algorithms and the requirement for sophisticated power electronics. As a result of its ability to convert electrical power between various voltage levels and frequencies, variable frequency transformers are crucial parts of contemporary power networks. They make it possible to include renewable energy sources, improve the quality of the electricity, and make it easier to transmit power across systems with various frequency standards.

## CONCLUSION

Power networks cannot function without transformers because they make it possible for electricity to be transmitted reliably and effectively. They act as the foundation for voltage change, guaranteeing lossless transmission of electrical energy across extended distances. Additionally, transformers offer isolation by dividing various components of the power system and improving security. They also make impedance matching possible, guaranteeing ideal power transmission between linked systems. The performance and dependability of power systems continue to be improved by the creation of sophisticated transformer designs and technologies, which also makes it possible to integrate renewable energy sources and boost system efficiency. The Transformer will continue to be an essential part of power systems as they develop, contributing significantly to the dependable and sustainable production, transmission, and distribution of electrical energy.

**REFERENCES:**

- [1] A. Gillioz, J. Casas, E. Mugellini, and O. A. Khaled, "Overview of the Transformer-based Models for NLP Tasks," in *Proceedings of the 2020 Federated Conference on Computer Science and Information Systems, FedCSIS 2020*, 2020. doi: 10.15439/2020F20.
- [2] J. W. Coltman, "The transformer [historical overview]," *IEEE Ind. Appl. Mag.*, 2002, doi: 10.1109/2943.974352.
- [3] M. R. Hussain, S. S. Refaat, and H. Abu-Rub, "Overview and Partial Discharge Analysis of Power Transformers: A Literature Review," *IEEE Access*. 2021. doi: 10.1109/ACCESS.2021.3075288.
- [4] M. Shayestegan, "Overview of grid-connected two-stage transformer-less inverter design," *Journal of Modern Power Systems and Clean Energy*. 2018. doi: 10.1007/s40565-017-0367-z.
- [5] H. Shadfar, M. Ghorbani Pashakolaei, and A. Akbari Foroud, "Solid-state transformers: An overview of the concept, topology, and its applications in the smart grid," *International Transactions on Electrical Energy Systems*. 2021. doi: 10.1002/2050-7038.12996.
- [6] M. Fallah, "An Overview of Different Transformer-based Language Models," *Ezra Tech Blog*, 2021.
- [7] B. Yang, J. Zhao, Z. Ji, J. Wang, and K. Liu, "Overview of hybrid transformer technologies," *Dianli Zidonghua Shebei/Electric Power Automation Equipment*. 2020. doi: 10.16081/j.epae.202001034.
- [8] J. Singh, R. Dahiya, and L. M. Saini, "Recent research on transformer based single DC source multilevel inverter: A review," *Renewable and Sustainable Energy Reviews*. 2018. doi: 10.1016/j.rser.2017.10.023.
- [9] J. S. BANOVIC, Mladen, "Classification of Transformers Family," *Technol. BASICS*, 2019.
- [10] A. Secic, M. Krpan, and I. Kuzle, "Vibro-Acoustic Methods in the Condition Assessment of Power Transformers: A Survey," *IEEE Access*. 2019. doi: 10.1109/ACCESS.2019.2923809.

## WORKING PRINCIPLE OF SINGLE-PHASE TRANSFORMER

**Mrs. Ramya\***

\*Assistant Professor,  
Department of Electrical And Electronics Engineering,  
Presidency University, Bangalore, INDIA  
Email Id-ramyak@presidencyuniversity.in

---

### ABSTRACT:

*An essential part of electrical power systems, a single-phase transformer is utilized for voltage transformation, isolation, and impedance matching. It comprises of a magnetic core and one to two windings, known as the main and secondary windings in most cases. In order to transport electrical energy between two circuits at the same frequency but with differing voltage levels, single-phase transformers are frequently utilized in power distribution systems. It is made up of two or more wire coils twisted around a single iron core. An overview of single-phase transformers, including its construction, operation, and many applications, is given in this chapter. The major points discussed in the study are briefly highlighted in the chapter.*

**KEYWORDS:** Core Losses, Eddy Current Losses, Single Phase Transformer, Turn Ratio, Voltage Transformation.

---

### INTRODUCTION

This kind of transformer is frequently utilized in domestic, business, and industrial settings. A single-phase transformer's secondary winding is linked to the load, while the primary winding is connected to the source of the input voltage. When an alternating current (AC) passes through the primary winding, it creates a magnetic field in the core. Based on the ratio of turns between the primary and secondary windings, this magnetic field subsequently produces a voltage in the secondary winding. A transformer's main purpose is to convert voltage. The transformer may increase or decrease the input voltage by adjusting the number of turns in the primary and secondary windings to the appropriate level. This is essential for effective power distribution and transmission because it enables high-voltage transmission over long distances to reduce power losses before stepping down the voltage to levels that are safe for consumers to use. Another crucial feature of single-phase transformers is isolation. A safety barrier between the input and output circuits is created by the electrical isolation between the primary and secondary windings. The linked devices or loads are shielded from high-voltage transients, surges, and faults that might happen on the primary side by this isolation[1]–[3].

In order to accomplish impedance matching, transformers with various turns ratios are used. Maximum power transmission may be obtained by matching the source and load impedances. This is crucial when connecting several electrical systems or in circumstances where the load impedance fluctuates. The transformer serves as a middleman, making sure that the load receives the most power possible. There are many different single-phase transformer configurations, including core-type and shell-type transformers. Transformers of the core-type have the windings wrapped around the core, whereas those of the shell-type have the windings around the core.



Both designs offer benefits, and the choice is made based on the needs of the individual application, such as size, cost, and efficiency. Efficiency is important while designing transformers. Transformers are made to reduce losses that result from resistive, eddy, and hysteresis losses in the core and windings.

To increase efficiency, efforts are made to employ conductors with low resistance for the windings and high-quality magnetic materials for the core. Single-phase transformers need to be periodically inspected for indicators of overheating, insulation deterioration, loose connections, and other maintenance issues. To ensure the dielectric strength of the insulating oil, routine oil analyses are carried out on transformers that are submerged in oil. To prevent against errors and odd circumstances, transformers are often fitted with safety features like temperature sensors and pressure release systems. Finally, it should be noted that single-phase transformers are crucial parts of electrical power networks. Assuring effective power transfer and secure operation, they enable voltage transformation, isolation, and impedance matching. These transformers are essential in supplying electricity to a number of industries, including the residential, commercial, and industrial sectors. The creation of more effective and sophisticated single-phase transformers will help power systems continue to advance, improving the overall performance and dependability of the system.

**Working principle of Single-Phase Transformer:** In order to move electrical energy from one circuit to another, a single-phase transformer relies on the interplay of magnetic fields and electrical currents. It is a static device made up of two or more windings coils of wire wrapped around a single magnetic core. The transformer functions according to electromagnetic induction theory, in which a shifting magnetic field causes a voltage to be induced in a nearby conductor. A laminated iron core, a secondary winding, and a primary winding make up the fundamental components of a single-phase transformer. The input voltage source is linked to the main winding, while the load or output circuit is connected to the secondary winding. For the flux produced by the windings, the core, which is typically constructed of high-permeability material like laminated silicon steel, offers a closed magnetic route. A time-varying magnetic field is produced when an alternating current (AC) passes through the primary coil.

According to Faraday's law of electromagnetic induction, this magnetic field produces a voltage in the secondary winding. The transformer's turns ratio defined as the ratio of the turns in the secondary winding to the turns in the primary winding determines the size of the induced voltage. An alternating magnetic field develops in the core during operation as a result of the primary winding's AC current. Through the secondary winding, this magnetic field induces an AC voltage. The turns ratio and the applied voltage at the primary winding both affect how much induced voltage there is. The power system determines the transformer's operating frequency, which is commonly 50 or 60 Hz. The primary winding's alternating current creates an alternating magnetic field that rises and falls in response to the shifting current. The secondary winding, which is linked to the load, experiences an alternating voltage as a result of the magnetic field. The voltage level at the secondary winding in relation to the primary winding is determined by the transformer's voltage transformation ratio. The secondary voltage of a step-up transformer is greater than the main voltage, allowing for the loss-free transmission of power across extended distances.

On the other hand, a step-down transformer lowers the voltage level, making it appropriate for use and distribution. The conservation of energy concept underlies the transformer's operation. Without accounting for losses, the power on the primary side ( $P_p$ ) is equal to the power on the secondary side ( $P_s$ ). As a result, the secondary voltage ( $V_s$ ) and secondary current ( $I_s$ ) are identical to the main voltage ( $V_p$ ) and primary current ( $I_p$ ) product. Transformers not only change the voltage but also provide an electrical barrier between the primary and secondary circuits. The insulation between the windings improves safety by preventing direct electrical contact. Transformers must have efficiency as one of its primary features. Hysteresis losses in the core, eddy current losses, and resistive heating of the windings all cause losses in the transformer. Transformer construction and design aims to reduce these losses and boost overall effectiveness. Power generation, transmission, distribution, and electrical devices all make extensive use of single-phase transformers. They are essential parts of power systems because they make it possible to regulate voltage and transmit energy effectively. Because of the requirement for greater efficiency, compact size, and compatibility with renewable energy sources, transformer design and performance continue to advance. Electromagnetic induction, where a shifting magnetic field induces a voltage in a nearby conductor, is the basis of the operation of a single-phase transformer. Transformers allow for voltage transformation and electrical isolation in power systems by employing a main and secondary winding configuration on a shared core. They are essential in the efficient transmission, distribution, and use of electrical energy.

## DISCUSSION

**Construction of Single-Phase Transformer:** A single phase transformer is an essential part of electrical power networks because it makes voltage distribution and transformation possible. It comprises of a number of crucial components that cooperate to provide effective and dependable power transfer. This page gives a thorough explanation of how a single-phase transformer is built.

- 1. Core:** The transformer's core, which acts as the magnetic circuit, is the transformer's primary component. To reduce magnetic losses, it is often built of high-permeability materials such laminated silicon steel. The primary winding's magnetic flux travels along a low-reluctance path through the core, resulting in effective energy transmission.
- 2. Windings:** Two windings, the primary winding and secondary winding, make up the transformer. The input voltage is sent to the primary winding, while the output voltage is sent out through the secondary winding. Insulated copper conductors are twisted around the core to create these windings. The voltage ratio between the main and secondary sides is determined by the number of turns in each winding.
- 3. Insulation:** Using the right insulation during the building of a transformer is essential for preventing electrical failure and ensuring safety. Paper, enamel, or synthetic varnishes are used as insulation for the windings. Insulation lowers losses brought on by leakage currents and prevents short circuits [4]–[6].
- 4. Tanks and Cooling System:** A steel or aluminum tank contains the transformer. The tank stores the transformer oil while also serving as mechanical protection. For insulation and cooling, transformer oil, such as mineral oil or synthetic oil, is utilized. The tank frequently has cooling fins or radiators added to it to disperse extra heat produced during operation.

5. **Tap Changer:** A tap changer is a device that enables modifying the transformer's turns ratio and, as a result, its output voltage. It comprises of a selection switch coupled to a series of taps on the winding. The voltage can be altered to account for fluctuations in the input voltage or load circumstances by altering the tap position.
6. **Bushings:** To connect the windings to the external power system, insulating bushings are used. They offer a way for conductors to enter and depart safely while preserving electrical isolation. Typically, bushings are constructed of porcelain or a composite material.
7. **Protective Devices:** Transformers include a number of protection mechanisms to guarantee dependable and secure functioning. These include the Buchholz relay, overcurrent protection, and over temperature protection. While over temperature protection devices defend against overheating, overcurrent protection devices protect the windings against excessive current flow. The Buchholz relay is a gas- and oil-powered instrument that looks for internal problems like short circuits or deterioration of the transformer oil.
8. **Accessories:** To improve performance and functionality, additional accessories may be built into a single-phase transformer. Examples include silica gel breathers, which regulate moisture levels inside the transformer, and conservator tanks, which handle oil expansion and contraction.

The important parts such the core, windings, insulation, tanks, cooling systems, tap changers, bushings, protective devices, and accessories are used in the building of single-phase transformers. To ensure effective power transmission, voltage transformation, and electrical isolation, each component is essential. For electrical power systems to operate reliably and safely, a single-phase transformer must be designed and built properly.

**E.M.F Equation of Single-Phase Transformer:** The induced electromotive force (EMF) in the main winding of a single-phase transformer is related to the applied voltage and the turns ratio of the transformer by the EMF equation. The equation is developed using electromagnetic induction's Faraday's law. Consider a single-phase transformer with  $N_1$  primary winding turns and  $N_2$  secondary winding turns. The main winding's applied voltage is designated as  $V_1$ , while the secondary winding's induced voltage is designated as  $V_2$ . Faraday's law states that the induced EMF in a coil is inversely proportional to the rate at which the magnetic flux connecting the coil changes. The primary winding of a transformer produces the magnetic flux, which connects the primary and secondary windings. The magnetomotive force (MMF) and the magnetic path's resistance are both exactly proportional to the magnetic flux  $\Phi$ , or, and respectively. The MMF contribution from the windings outweighs the magnetic path reluctance in a well-designed transformer. Consequently, we may write the magnetic flux as follows:

$$\Phi \propto \text{MMF} = N_1 \times I_1$$

Where  $I_1$  denotes the primary winding's current.

Since the secondary winding has a different number of turns than the primary winding, we may write:

$$\Phi = k \times N_2 \times I_2$$

Where  $I_2$  is the secondary winding's current and  $k$  is a constant relating the transformer's turns ratio, as shown by:

$$k = N_2 / N_1$$

Currently, the magnetic flux is changing at a rate of:

$$d\Phi/dt = k \times d(N_2 \times I_2)/dt$$

$N_2$  being a constant, the equation may be reduced to:

$$d\Phi/dt = k \times N_2 \times dI_2/dt$$

The secondary winding experiences an EMF as a result of the magnetic flux's rate of change. Faraday's law states that the following sources produce this EMF:

$$EMF = -d\Phi/dt$$

Therefore:  $EMF = -k \times N_2 \times dI_2/dt$

The EMF produced in a single-phase transformer's secondary winding is represented by this equation. It demonstrates how the secondary winding's current change rate ( $dI_2/dt$ ) and turns ratio ( $k$ ) affect the induced EMF. The opposition of the induced EMF to the current change is shown by the negative sign. Remember that this calculation makes the assumption that the transformer is perfect and has no losses. Real-world transformers have losses including copper and core losses, which have an impact on their performance. The link between the applied voltages, turns ratio, and induced voltage in a single-phase transformer may, nevertheless, be understood fundamentally using the EMF equation.

**Operation of Single-Phase Transformer:** Transforming voltage levels from the primary winding to the secondary winding while retaining frequency is necessary for a single-phase transformer to function. It entails the following actions:

**a. Input Voltage Application:** Alternating current (AC) voltage is applied to the transformer's primary winding as the input voltage. A power generating source or another transformer in a power distribution system may provide this voltage.

**b. Magnetic Flux Generation:** The primary winding of a transformer experiences a fluctuating magnetic field when an AC voltage is supplied to it. Due to electromagnetic induction, this magnetic field causes a matching voltage to be induced in the secondary winding[7]–[9].

**c. Voltage Transformation:** The voltage transformation between the main and secondary windings of the transformer is governed by its turn's ratio. The number of turns in the secondary winding ( $N_2$ ) divided by the number of turns in the main winding ( $N_1$ ) is known as the turns ratio. This formula for the voltage transformation is:

$$V_2 = (N_2 / N_1) \times V_1$$

Where  $V_1$  is the main winding's input voltage and  $V_2$  is the secondary winding's output voltage.

**d. Impedance Transformation:** A transformer not only converts voltage, but also permits impedance transformation. According to the turn's ratio, the secondary winding reflects the impedance that was observed by the first winding. This makes it possible to optimize power transmission by matching the source impedance on the main side with the load impedance linked to the secondary side.

**e. Energy Transfer:** Energy is transferred from the primary winding to the secondary winding by the fluctuating magnetic field within the transformer core. The secondary winding experiences an electromotive force (EMF) due to the magnetic field, which propels the current.

**f. Load Connection:** Utilizing the converted voltage and impedance, the load is linked to the secondary winding. Depending on the application, the load might be any number of electrical components, including motors, lights, or appliances.

**g. Galvanic and Electrical Isolation:** A transformer's ability to provide galvanic and electrical isolation between the main and secondary windings is one of its many noteworthy features. By preventing a direct electrical connection between the primary and secondary circuits, this separation increases safety and safeguards equipment.

**h. Efficiency and Losses:** While in use, transformers suffer from a number of losses, including copper losses caused by resistance in the windings and core losses due to hysteresis and eddy current losses. The transformer's efficiency is decreased by these losses. By choosing the right materials and conducting adequate design, these losses are attempted to be reduced.

**i. Cooling and Protection:** Transformers produce heat when they are operating, and this heat is dissipated via cooling devices like fans, radiators, or oil circulation. In order to defend against faults, high temperatures, and internal failures, transformers are also fitted with safety features including overcurrent relays, temperature sensors, and pressure relief valves.

These procedures allow for the efficient and reliable flow of electrical energy from the primary to the secondary winding of a single-phase transformer, as well as for voltage transformation and impedance matching in accordance with the turns ratio. It is essential to the creation, transmission, and distribution of electricity because it makes it possible to use electrical energy effectively.

**Single Phase Transformer's losses:** Various losses of different kinds occur while a single-phase transformer is in operation. Core losses, commonly referred to as iron losses, and copper losses are the two primary categories into which these losses may be divided.

**1. Core Losses:** Core losses can happen even when there isn't a load attached to the secondary winding and are mostly related to the magnetic characteristics of the transformer core. Core losses are composed of two parts:

**a. Hysteresis Loss:** The magnetization and demagnetization of the core material with each alternating cycle of the applied voltage causes hysteresis loss. Heat loss as a result of energy losses.

**b. Eddy Current Loss:** The changing magnetic field causes eddy currents to form in the core. These circulating currents cause energy losses and heat production. By offering an eddy current route with greater resistance, the usage of laminated or layered core materials lowers eddy current losses.

Core losses are inversely correlated with supply frequency, magnetic flux density, and core material quality. By utilizing premium core materials with less hysteresis and eddy current losses, they can be reduced.



**2. Copper Losses:** The conductor's resistance causes copper losses in the transformer windings. There are two parts to copper losses:

**a. Ohmic ( $I^2R$ ) Loss:** Resistive losses occur when current passes through the primary and secondary windings' resistance. By employing conductors with low resistance, these losses, which are inversely proportional to the square of the current flowing through the windings, may be minimized.

**b. Leakage Reactance Loss:** Transformers are not perfect, and a small amount of leakage flux exists that does not connect the two windings. This leakage flux causes the windings to develop leakage reactance, which increases losses since current passes through it.

By employing conductors with low resistivity, designing windings properly to limit leakage reactance, and choosing the right conductor diameters to reduce resistive losses, copper losses may be kept to a minimum.

It's crucial to remember that while copper losses rise with load current, core losses remain constant and unaffected by the load connected to the secondary winding. The total of core losses and copper losses is taken into consideration when evaluating the overall effectiveness of a single-phase transformer. The transformer's effectiveness is determined by:

$$\text{Efficiency} = (\text{Output Power} / \text{Input Power}) \times 100$$

The transformer's efficiency is a metric for how well it transfers electrical power from the input side to the output side while minimizing energy losses. In order to cut losses and boost efficiency, transformer designs and materials are optimized. This entails choosing the right core materials, minimizing air gaps within the core, utilizing copper conductors with excellent conductivity, and implementing efficient cooling systems to remove heat. By reducing losses, the transformer's total efficiency is raised, resulting in more cost-effective and environmentally friendly operation.

**Testing of Single-Phase Transformer:** A single phase transformer must be tested to guarantee appropriate functioning, effectiveness, and dependability. Throughout the transformer's lifetime, many tests are carried out both often and throughout the production process. The following tests are frequently carried out on single phase transformers:

- 1. Test for Turns Ratio:** This test confirms the transformer's turns ratio. Measure the voltage that results in the secondary winding after applying a known voltage to the primary winding. The measured turns ratio must line up with the transformer's required turns ratio.
- 2. Open Circuit Test (No-load Test):** The core losses, including hysteresis and eddy current losses, are determined by the open circuit test (no-load test). In this test, the primary winding is subjected to a lower voltage while the secondary winding is left open. The no-load current and losses are calculated by measuring the primary current and power input [10].
- 3. Impedance test and short circuit test:** The transformer's impedance voltage and copper losses are assessed during the transformer's short circuit test. The secondary winding is short-circuited, and the primary winding receives a lower voltage. The short circuit current and losses are calculated by measuring the primary current, voltage, and power input.

4. **Winding Resistance Test:** Test for Winding Resistance: In this test, the resistance of the primary and secondary windings is determined. Each winding is given a known DC voltage, and the resultant current is measured. Ohm's law is used to compute the resistance.
5. **Insulation Resistance Test:** The insulation resistance test assesses the transformer's insulation capabilities. The insulation resistance is measured when a high voltage DC source is supplied between the transformer core and the windings. This test guarantees that the insulation of the transformer is in good condition, avoiding any leakage current or electrical breakdown.
6. **Load Loss Test:** The load loss test calculates the transformer's overall losses while it is operating at full capacity. The input power and losses of the transformer are monitored while the secondary side is loaded with a predetermined current. This test aids in determining the efficiency and power loss characteristics of the transformer under load.
7. **Temperature Rise Test:** The temperature rise test measures the thermal performance of the transformer and assesses its capacity to disperse heat. Temperature readings are obtained throughout the transformer while it is loaded to its rated capacity in order to gauge the temperature rise. The recorded temperatures are contrasted with the temperature ranges for the transformer.
8. **Dielectric testing:** Dielectric tests verify the transformer's electrical stability and insulation integrity. In these tests, high voltage AC or DC voltages are applied for a predetermined amount of time to the windings and between the windings and the core to test for insulation failure or excessive leakage current.

Depending on the specific criteria and standards that apply to the transformer, further tests including harmonic analysis, short-time current testing, and impulsive voltage tests may also be conducted. By performing these tests, you may be confident that the single phase transformer complies with all the requirements for performance, safety, and specifications. They assist with locating any potential flaws or problems so that remedial measures may be done before the transformer is placed into operation. Throughout the transformer's working life, routine maintenance and testing are also carried out to guarantee sustained dependability and performance.

## CONCLUSION

Power distribution systems rely on single-phase transformers to effectively transport electrical energy between circuits with various voltage levels. In several applications, including those in the residential, commercial, and industrial sectors, they are crucial elements. A single-phase transformer's design, which involves winding coils around an iron core, enables strong magnetic coupling and effective energy transmission. Designing and maintaining power distribution networks requires a thorough understanding of the single-phase transformer's features and operating theory. The knowledge provided in this paper lays the groundwork for further investigation and study in the area of electrical transformers, advancing the discipline of power systems engineering.

## REFERENCES:

- [1] T. Drabek and P. Dybowski, "Control of the transformer phase powers using a single-

- phase voltage source†,” *Energies*, 2021, doi: 10.3390/en14041038.
- [2] D. Sha, D. Zhang, and J. Zhang, “A Single-Stage Dual-Active-Bridge AC-DC Converter Employing Mode Transition Based on Real-Time Calculation,” *IEEE Trans. Power Electron.*, 2021, doi: 10.1109/TPEL.2021.3058143.
- [3] L. Gu and W. Zhu, “Single-stage high-frequency-isolated three-phase four-leg buck-boost inverter with unbalanced load,” *IET Power Electron.*, 2020, doi: 10.1049/iet-pel.2019.0436.
- [4] M. Vallès, M. Bourouis, and D. Boer, “Solar-driven absorption cycle for space heating and cooling,” *Appl. Therm. Eng.*, 2020, doi: 10.1016/j.applthermaleng.2019.114836.
- [5] I. G. Krisnayoga Kusuma, I. G. Dyana Arjana, and I. W. Arta Wijaya, “STUDI ANALISA KOORDINASI RELAI GFR INCOMING BUSBAR 20 KV DAN GFR SALURAN UNTUK MENGAMANKAN GANGGUAN SATU PHASA KETANAH DI TRANSFORMATOR 3 GARDU INDUK KAPAL,” *Maj. Ilm. Teknol. Elektro*, 2017, doi: 10.24843/mite.2017.v16i02p04.
- [6] S. Riegler, E. Schweiger, C. Ettl, M. Stössl, and S. Bose, “Recommendation of site commissioning tests for rapid recovery transformers with an installation time less than 30 hours,” *Elektrotechnik und Informationstechnik*, 2018, doi: 10.1007/s00502-018-0669-5.
- [7] G. Sha *et al.*, “A Multiport Electric Energy Routing Scheme Applied to Battery Energy Storage System,” *J. Eng. (United Kingdom)*, 2021, doi: 10.1155/2021/6637926.
- [8] R. Bass, R. Harley, F. Lambert, V. Rajasekaran, and J. Pierce, “Residential harmonic loads and EV charging,” *Proc. IEEE Power Eng. Soc. Transm. Distrib. Conf.*, 2001, doi: 10.1109/PESW.2001.916965.
- [9] F. H. M. Rafi, M. J. Hossain, M. S. Rahman, and S. Taghizadeh, “An overview of unbalance compensation techniques using power electronic converters for active distribution systems with renewable generation,” *Renewable and Sustainable Energy Reviews*. 2020. doi: 10.1016/j.rser.2020.109812.
- [10] X. Luo, Q. Xiao, Q. Wang, W. Gan, B. Deng, and C. Fang, “Research on Short-Circuit Force of Distribution Transformer Based on Short-Circuit Test by Single-Phase Power and Three-phase Power,” in *2021 3rd Asia Energy and Electrical Engineering Symposium, AEEES 2021*, 2021. doi: 10.1109/AEEES51875.2021.9403173.

## OVERVIEW OF THREE PHASE TRANSFORMER

**Mrs. Ragasudha Chundampunathil\***

\*Assistant Professor,  
Department of Electrical And Electronics Engineering,  
Presidency University, Bangalore, INDIA  
Email Id-ragasudha@presidencyuniversity.in

---

### ABSTRACT:

*An essential part of power networks that enables the effective transmission and distribution of electrical energy is the three-phase transformer. Three primary windings and three secondary windings make up this transformer's structure, which enables the conversion of voltage levels while preserving the harmony between phases. This chapter gives a general overview of the three-phase transformer used in electrical power systems, emphasizing its design, operation, and applications. The summary highlights the relevance of three-phase transformers in the contemporary power sector and summarizes the major ideas covered in the chapter.*

**KEYWORDS:** *Construction, E.M.F. Equation, Operation, Transformer Losses, Three Phase Transformer.*

---

### INTRODUCTION

A transformer type known as a three-phase transformer is made to manage three-phase electrical electricity in power systems. It has a common magnetic core that is looped around three main windings and three secondary windings. The secondary windings are connected to the load or distribution system, whereas each main winding is connected to a different phase of the power system. A three-phase transformer's primary function is to maintain phase balance while converting electrical energy from one voltage level to another voltage level. This is essential for power systems that generate energy at high voltages before stepping it down to lower voltages for distribution and use. Transformers with three phases are often employed in power plants, transmission systems, industrial facilities, and commercial buildings.

A three-phase transformer is built similarly to a single-phase transformer, but with more windings and a more intricate core. Depending on the exact application and system needs, the main and secondary windings are often linked in either a star (wye) or delta form. A channel for the magnetic flux created by the currents running through the windings is provided by the magnetic core, providing effective energy transfer between phases. A three-phase transformer works using the electromagnetic coupling and magnetic induction theories. Alternating current causes a shifting magnetic field that produces a voltage in the secondary windings when it passes through the primary windings. The transformer's voltage transformation ratio is determined by the turn's ratio between the primary and secondary windings. In order to effectively transmit and distribute electrical energy, three-phase transformers are essential parts of power networks. They convert voltage while keeping phase balance, supplying dependable and stable power to a variety of applications. The reliable operation of power systems and the overall efficiency of the electrical grid depend on the right design, installation, and maintenance of three-phase transformers[1]–[3].

---

**Working Principle of Three phase Transformer:** A three-phase transformer's basic operation entails converting electrical energy between various voltage levels while preserving phase balance. Magnetic induction and electromagnetic coupling are the foundation of this procedure. Three main windings and three secondary windings are wrapped around a single magnetic core to make a three-phase transformer. The secondary windings are connected to the load or distribution system, whereas each main winding is connected to a different phase of the power system. The magnetic flux produced by the currents flowing through the windings has a route through the magnetic core. By taking into account the subsequent actions, the three-phase transformer's operating principle may be understood:

- a. **Voltage Generation:** Alternating current (AC) is the form in which electricity is produced at power plants for use in a power system. The primary windings of the three-phase transformer conduct AC electricity. Depending on the particular application and system requirements, the principal windings are often linked in either a star (wye) or delta arrangement.
- b. **Magnetic Field Production:** As the primary windings' primary current passes through them, a shifting magnetic field is produced around each winding. Through electromagnetic induction, the magnetic field causes a voltage to be induced in the secondary windings. The size of the induced voltage depends on the magnetic flux and the number of turns in the windings.
- c. **Voltage Transformation:** The magnetic flux produced by the primary winding's links with the secondary windings due to the connection between the primary and secondary windings. As a result, electrical energy can go from the main side to the secondary side. The transformer's voltage transformation ratio is determined by the turn's ratio between the primary and secondary windings. A primary voltage of 10 kV can be changed into a secondary voltage of 20 kV, for instance, if the turns ratio is 1:2.
- d. **Phase Balance:** Maintaining phase balance is one of the most important aspects of three-phase transformers. Each phase in a three-phase power system is 120 degrees apart from the others. The phase connection between the transformer's primary and secondary windings must be maintained at all costs. In order for electrical equipment to function well, it is essential that the load receive a balanced, three-phase supply free of phase changes.
- e. **Efficiency & Losses:** The transformer faces losses during the voltage transformation process as a result of a number of causes, including resistance, magnetic hysteresis, and eddy currents. Heat is produced as a result of these losses, which lowers the transformer's efficiency. Transformers are made with high-quality magnetic cores, insulated windings, and cooling mechanisms like oil or air cooling to minimize losses. Transformers that are efficient reduce losses and provide effective energy transmission.
- f. **Protection and Control:** Three-phase transformers are outfitted with protective mechanisms and control systems to ensure dependable and secure operation. To protect the transformer against faults, overloads, and high temperatures, protection devices including circuit breakers, fuses, and temperature sensors are used. To ensure stability and avoid voltage swings, control systems track and manage the voltage and current levels.



The conversion of electrical energy between various voltage levels while preserving phase balance constitutes the fundamental function of a three-phase transformer. Three-phase transformers effectively move power from the primary windings to the secondary windings thanks to the concepts of magnetic induction and electromagnetic coupling. The voltage transformation ratio is determined by the turn's ratio, and the magnetic core acts as a conduit for the magnetic flux. Three-phase transformers are essential for the effective transmission and distribution of electrical energy in power networks because they ensure phase balance and reduce losses.

## DISCUSSION

**Construction of Three Phase Transformer:** To handle the three phases, a three-phase transformer is built similarly to a single-phase transformer, but with more windings and a more intricate core design. The following essential elements are part of the construction:

- 1. Core:** Laminated sheets of electrical-grade steel are generally used to construct the core of three-phase transformers. By giving the circulating currents a channel with greater resistance, these laminations reduce eddy current losses. The core structure is created by stacking and insulating the laminations. The magnetic flux created by the windings is intended to go along a low-reluctance path through the core.
- 2. Windings:** Three sets of windings three main windings and three secondary windings make up a three-phase transformer. The core is surrounded by each set of windings, which are separated from one another and the core. The windings are often insulated with materials like paper or enamel and constructed of copper or aluminum conductors. The power source is linked to the main windings, while the load or distribution system is connected to the secondary windings.
- 3. Insulation:** In a three-phase transformer, insulation is essential to avoid electrical breakdown between the windings and the core as well as inside the windings. Electrical insulation is provided by the use of insulating materials such as varnish, paper, or composite materials, which are utilized to separate the windings. Insulation also aids in shielding the windings from pollutants like moisture, dust, and other impurities.
- 4. Cooling system:** A cooling system is used to disperse the heat produced while a transformer is operating. Oil cooling and air cooling are typical cooling techniques. Transformer oil, which serves as both a coolant and an insulator in oil-cooled transformers, is submerged into the windings and core of the device. To remove heat, the oil is circulated through radiators or cooling pipes. The windings and core of air-cooled transformers are exposed to air, and fans or natural convection help to dissipate heat.
- 5. Tap Changer:** Some three-phase transformers have a tap changer mechanism that enables the output voltage and turns ratio to be adjusted. Tap changers are used to adapt to various load situations or to make up for input voltage variations. Depending on whether the taps may be changed while the transformer is under load or not, they can either be on-load tap changers (OLTC) or off-load tap changers (OLTC) [4]–[6].
- 6. Accessories and Protection:** Three-phase transformers may also come with a number of accessories and protective mechanisms. These can include grounding systems to assure

safety and protection, pressure relief devices, temperature sensors to monitor winding temperatures, and Buchholz relays to find internal defects.

A core, many sets of windings, insulation, cooling systems, tap changers, and different accessories are all used in the building of a three-phase transformer. Together, these parts enable the efficient and dependable transfer of electrical energy between various voltage levels while preserving phase equilibrium. The building is meticulously planned to reduce losses, guarantee insulation integrity, and offer the best performance possible in power systems.

**E.M.F Equation of Three Phase Transformer:**The voltage produced in the windings of a three-phase transformer is related to the number of turns, magnetic flux, and frequency using the EMF (electromotive force) equation. Depending on whether we are looking at the main (P) or secondary (S) winding, the EMF equation changes somewhat. The EMF equations for each winding are as follows:

**1. Primary Winding (P):** The following equation describes the induced EMF in a three-phase transformer's primary winding:

$$E_{ip} = 4.44 * f * N_{ip} * \Phi_m$$

Where:  $E_{ip}$  is the induced EMF in the primary winding,

$f$  is the frequency of the AC supply,

$N_{ip}$  is the number of turns in the primary winding, and

$\Phi_m$  is the magnetic flux in Weber (Wb) linking the primary winding.

**2. Secondary Winding (S):** The following equation describes the induced EMF in a three-phase transformer's secondary winding:

$$E_{is} = 4.44 * f * N_{is} * \Phi_m$$

Where:  $E_{is}$  is the induced EMF in the secondary winding,

$N_{is}$  is the number of turns in the secondary winding, and

$\Phi_m$  is the magnetic flux in Weber (Wb) linking the secondary winding.

It's crucial to remember that the EMF calculations make the assumption that the transformer operates under ideal circumstances, with no losses and excellent magnetic coupling between the windings. The actual voltage levels in a transformer are impacted by a variety of losses, including leakage flux, core losses, and copper losses in practice. Understanding the voltage transformation process and figuring out the turns ratio necessary to obtain the desired output voltage depend on the three-phase transformer's EMF equations. Additionally, they assist in developing and choosing transformers for particular applications as well as in studying the behavior of the transformer under various load situations.

**Operation of Three Phase Transformer:**A three-phase transformer must convert electrical energy between various voltage levels while preserving phase balance in order to function. Phase balance and voltage transformation are its two fundamental components.

- 1. Voltage Conversion:** A three-phase transformer's main job is to change the voltage from one level to another. The electromagnetic interaction between the main and secondary

windings allows for the transformation. The voltage transformation ratio is based on the transformer's turns ratio. A magnetic field is produced in the transformer core when three-phase AC electricity is applied to the primary windings. Through electromagnetic induction, this magnetic field causes voltage to be induced in the secondary windings. The amount of induced voltage depends on the turn's ratio. A primary voltage of 10 kV can be changed into a secondary voltage of 20 kV, for instance, if the turns ratio is 1:2.

2. **Phase Balancing:** In a three-phase electrical system, each phase is offset from the others by 120 degrees. When a three-phase transformer is operating, maintaining phase balance is crucial. The allocation of electrical power and load among the three phases in accordance with phase balance.

The three-phase transformer's windings must be appropriately connected in order to accomplish phase balancing. Depending on the particular application and system requirements, the principal windings are often linked in either a star (wye) or delta arrangement. Similar connections are made for the secondary windings. The power is divided equally throughout the three phases and the voltage and current in each phase are balanced by making sure the windings are linked appropriately. The successful operation of electrical equipment linked to the transformer depends on maintaining phase balance. Voltage fluctuations, unbalanced currents, and poor equipment performance might result from an uneven allocation of power and load across the phases.

The functioning of a three-phase transformer includes concerns including losses, efficiency, cooling, and protection in addition to voltage transformation and phase balancing. Transformers suffer from a variety of losses, including core and copper losses brought on by magnetic hysteresis and eddy currents. Copper losses are caused by the resistance of the windings. Heat created during transformer operation is dissipated via cooling systems, such as oil or air cooling. To guarantee safe and dependable operation and guard against transformer damage, protection devices including circuit breakers and temperature sensors are fitted. A three-phase transformer's functioning entails voltage conversion between various voltage levels while preserving phase balance. The transformer effectively transforms electrical energy and equally distributes it across the three phases by correctly connecting the windings and guaranteeing the right turns ratio. To maintain a secure and dependable functioning, other factors including losses, cooling, and protection must be taken into account.

**Three Phase Transformer's losses:** Diverse losses that three-phase transformers incur during operation have an impact on their effectiveness and overall performance. The two primary categories of these losses are copper losses and core losses. An overview of the losses experienced in a three-phase transformer will be given in this response [7]–[9].

**Copper Losses:** Copper losses are caused by the transformer windings' resistance and are a direct result of the current that passes through them.  $I^2R$  losses and load losses are the two categories of copper losses.

a.  **$I^2R$  Losses:**  $I^2R$  losses, often referred to as resistive losses, are brought on by resistance that the current passing through the winding's encounters. According to Ohm's law, power is lost as heat when current flows through a conductor that has resistance. The  $I^2R$  losses in the transformer are represented by this thermal energy.

Primary winding losses and secondary winding losses are the two subgroups of the  $I^2R$  losses. The square of the current flowing through the primary winding and the resistance of the primary winding itself define the  $I^2R$  losses in the primary winding. Similar to the primary winding, the secondary winding's  $I^2R$  losses are determined by the resistance of the secondary winding and the square of the current in the secondary winding.

**Load Losses:** When a transformer is delivering electricity to a load, load losses also referred to as load current losses or load-dependent losses occur because of the current flowing through the windings. Copper losses in the main and secondary windings combine to form load losses. The square of the load current determines how much is lost. Calculating load losses involves multiplying the square of the load current by the total of the main and secondary winding resistances. With an increase in load current, load losses rise and add to the overall copper losses in the transformer.

**Core Losses:** The magnetic core of the transformer experiences core losses, sometimes referred to as iron losses or no-load losses. These losses are connected to the magnetic characteristics of the core material and are independent of the load current. Hysteresis losses and eddy current losses are the two additional subsets of core losses. As the alternating current flows through the windings, the core material is magnetized and demagnetized, resulting in hysteresis losses. The core material continually magnetizes and demagnetizes as a result of the alternating magnetic field, causing energy loss in the form of heat. The characteristics of the core material, such as its magnetic permeability and coercivity, affect hysteresis losses.

**Eddy Current Losses:** The shifting magnetic field causes eddy currents to form in the core material. These currents go through the core material and run into resistance, which causes energy to be lost as heat. The conductivity and thickness of the core laminations, as well as the frequency of the alternating current, all affect eddy current losses. Efforts are undertaken to reduce losses in three-phase transformers in order to increase their efficiency. This may be done in a number of ways:

- 1. High-quality Core Materials:** Using high-quality core materials with less hysteresis and eddy current loss can cut core losses dramatically. Due to their advantageous magnetic characteristics, silicon steel laminations are frequently employed.
- 2. Correct Core Design:** By reducing magnetic flux leakage and eddy currents, optimal core design can assist lower core losses. This includes choosing the right core form, size, and stacking method.
- 3. Effective Winding Design:**  $I^2R$  losses can be minimized by using copper or aluminum conductors with high conductivity and low resistance. Losses can also be decreased with the use of proper winding design methods, such as limiting skin and proximity effects.
- 4. Cooling systems:** Proper cooling systems, including oil or air cooling, aid in dissipating the heat produced by losses, ensuring that the transformer functions within safe temperature ranges.
- 5. Transformer Size:** Minimizing losses can be achieved by correctly sizing the transformer in accordance with the load requirements. Undersized transformers may be overloaded and cause additional losses, whereas oversized transformers may cause unneeded losses.

In summary, during operation, three-phase transformers suffer from copper losses ( $I^2R$  losses and load losses) as well as core losses (hysteresis losses and eddy current losses). These losses produce heat that needs to be dispersed and lower the efficiency of the transformer. A three-phase transformer's losses can be reduced, resulting in increased performance and efficiency, by adopting effective winding and core designs, high-quality materials, cooling systems, and optimum transformer size.

**Testing of Three Phase Transformer:** To verify their appropriate operation, performance, and conformity with design criteria, three-phase transformers must be tested. Three-phase transformers are put through a number of tests during the stages of production, installation, and maintenance. These tests aid in finding any problems, confirm their mechanical and electrical properties, and guarantee their dependability. The tests that are frequently carried out on three-phase transformers are as follows:

**1. Routine Tests:** Every three-phase transformer is subjected to routine tests to confirm the insulation integrity and fundamental electrical characteristics. These tests consist of:

1. **Test for Turns Ratio:** This test ascertains whether the turns ratio between the primary and secondary windings complies with design requirements.
2. **Winding Resistance Test:** This test determines if the primary and secondary windings' DC resistances reach the required levels, ensuring effective power transfer and minimizing losses.
3. **Open Circuit Test:** In the open circuit test, the secondary winding of the transformer is left open while the primary winding is powered with the rated voltage. This test calculates the magnetizing current and evaluates the core losses (no-load losses).
4. **Short Circuit Test:** During the short circuit test, the primary winding is cut off while a lower voltage is applied to the secondary winding. In this test, the transformer's impedance and copper losses under short-circuit circumstances are measured.

**2. Type Tests:** Type tests are performed on a sample transformer to assess how well it performs under particular operating circumstances. These tests give a thorough examination of the transformer and are more stringent. The following are some typical type tests for three-phase transformers[10]:

- a. **Test for Temperature Rise:** This test gauges the rise in temperature of the transformer at full load. It guarantees that the transformer can carry the designated load without going above the permitted temperature range.
- b. **Impulse Voltage Withstand Test:** Test evaluating the ability of a transformer's insulation to tolerate high-voltage impulses brought on by lightning strikes or switching events is known as the "impulse voltage withstand test."
- c. **Test for Short-Circuit Tolerance:** This test determines if a transformer can resist strong short-circuit currents without causing damage to its windings or other parts.
- d. **Sound Level Measurement:** During this test, the transformer's noise output is measured to make sure it complies with the required noise standards.



**3.Special testing:** Based on particular specifications or client preferences, special testing may be carried out. These tests could be: The ability of the transformer to withstand harmonic currents and voltages that may be present in the power system as a result of non-linear loads is evaluated using harmonic analysis.

- a. **Insulation Resistance Test:** To check the integrity of the insulation system, the insulation resistance test measures the insulation resistance between the windings and between the windings and the ground.
- b. **Polarity Test:** To guarantee appropriate phasing and connections, the polarity test checks the transformer windings' polarity.
- c. **Measurement of load losses and efficiency:** Under certain load circumstances, measurement of load losses and efficiency establishes the real losses and efficiency of the transformer.

It's vital to remember that testing methods may change according on global standards, particular transformer applications, and client needs. To provide accurate and trustworthy findings, testing should be done by competent professionals using the right test tools.

## CONCLUSION

By permitting the transmission and distribution of electrical energy at various voltage levels while guaranteeing phase balance, the three-phase transformer serves a critical function in power networks. Three main windings and three secondary windings are used in its construction to provide flexibility in voltage conversion. Three-phase transformers effectively transfer electricity from one phase to another by exploiting the electromagnetic coupling and magnetic induction principles. They are essential for many different applications, including as power production, transmission networks, industrial systems, and commercial buildings, because to their capabilities. Three-phase transformers must be properly designed, installed, and maintained for power systems to operate reliably and efficiently. The performance and dependability of three-phase transformers in contemporary power systems continue to be improved as a result of the development of novel transformer designs and control techniques.

## REFERENCES:

- [1] M. R. Iravani *et al.*, "Modeling and analysis guidelines for slow transients - Part III: the study of ferroresonance," *IEEE Trans. Power Deliv.*, 2000, doi: 10.1109/61.847260.
- [2] D. Korenciak and M. Gutten, "Fault diagnostics of transformer winding in time and frequency domain," *Diagnostyka*, 2020, doi: 10.29354/diag/125310.
- [3] A. Iraklis, T. Schirmer, H. Dittus, A. Lusiewicz, and J. Winter, "Overview of Three-Stage Power Converter Topologies for Medium Frequency-Based Railway Vehicle Traction Systems," *IEEE Trans. Veh. Technol.*, 2019, doi: 10.1109/TVT.2019.2895500.
- [4] E. So, R. Verhoeven, B. Simons, H. V. Parks, and D. Angelo, "A High-Precision Current Transformer for Loss Measurements of EHV Shunt Reactors," *IEEE Trans. Instrum. Meas.*, 2019, doi: 10.1109/TIM.2019.2899184.
- [5] M. A. Bahmani, E. Agheb, T. Thiringer, H. K. Hoidalén, and Y. Serdyuk, "Core loss behavior in high frequency high power transformers-I: Effect of core topology," *J. Renew.*

- Sustain. Energy*, 2012, doi: 10.1063/1.4727910.
- [6] N. Holtsmark, H. J. Bahirat, M. Molinas, B. A. Mork, and H. K. Høidalen, “An All-DC offshore wind farm with series-connected turbines: An alternative to the classical parallel AC model?,” *IEEE Trans. Ind. Electron.*, 2013, doi: 10.1109/TIE.2012.2232255.
- [7] M. Beltle, A. Muller, and S. Tenbohlen, “Statistical analysis of online ultrahigh-frequency partial-discharge measurement of power transformers,” *IEEE Electr. Insul. Mag.*, 2012, doi: 10.1109/MEI.2012.6340520.
- [8] M. R. Iravani *et al.*, “Study of ferroresonance,” *IEEE Trans. Power Deliv.*, 2000, doi: 10.1109/61.847260.
- [9] S. B. Skretas and D. P. Papadopoulos, “Efficient design and simulation of an expandable hybrid (wind-photovoltaic) power system with MPPT and inverter input voltage regulation features in compliance with electric grid requirements,” *Electric Power Systems Research*. 2009. doi: 10.1016/j.epsr.2009.03.010.
- [10] J. W. Kolar, U. Drogenik, and F. C. Zach, “VIENNA rectifier II - a novel single-stage high-frequency isolated three-phase PWM rectifier system,” *IEEE Trans. Ind. Electron.*, 1999, doi: 10.1109/41.778214.

## BASICS PRINCIPLES OF ELECTROMECHANICAL CONVERSION

**Mr. Sreekanth Kondreddy\***

\*Assistant Professor

Department of Electrical And Electronics Engineering,  
Presidency University, Bangalore, INDIA  
Email Id-ksreekanthreddy@presidencyuniversity.in

---

### ABSTRACT:

*In power systems, electromechanical conversion is essential for the effective conversion of electrical energy into mechanical energy and vice versa. An overview of the electromechanical conversion concepts used in power systems is provided in this chapter. It highlights the important elements and their functions while discussing the essential ideas and procedures involved in the conversion process. Electromagnetism, electromagnetic induction, and mechanical work are among the concepts explored. The research also examines how electromechanical conversion is used in power production, transmission, and usage. For the design, operation, and maintenance of power systems to ensure dependable and effective energy conversion, it is crucial to comprehend these concepts.*

**KEYWORDS:** *Electromechanical Conversion, Excited Magnetic Field, Electrical Energy, Energy Conversion, Permanent Magnets.*

---

### INTRODUCTION

The ability of electric energy to be transported across great distances with relative ease and high efficiency is its main advantage over other types of energy. Its primary purpose is as a transmission connection to move other types of energy, such as mechanical, acoustic, and visual energy, from one physical area to another. Natural sources of electric energy are few, as is their direct use. Clearly, two different types of energy conversion devices are required to transform a form of energy into electricity, and the other to transform it back into the original form or any other desired form. The devices for electromechanical energy conversion are the focus of this chapter. These gadgets can serve as low-energy conversion, processing, and transport transducers. These gadgets can serve as transducers for low-energy signal processing and transmission. A second group of such devices includes electromagnets, relays, actuators, etc., which are designed to produce force or torque with a restricted range of mechanical motion. Devices that convert energy continuously, such as motors or generators, fall into a third group and are used to convert and utilize large amounts of energy. The medium of a magnetic or electric field is used for electromechanical energy conversion; the magnetic field is most suited for use in actual conversion systems. Since mechanically moving parts have inertia, the fields must therefore be slowly changing, or quasistatic in nature. Although practical equipment may be built to specifically suit one way of conversion or the other, the conversion process is essentially reversible[1]–[3]. The comprehension of the electromechanical energy conversion concept is the major focus of this chapter. We'll use straightforward examples to illustrate our points. The analysis of continuous energy conversion machinery will be done in following chapters.

**Electromechanical Conversion Principles:** An essential idea in engineering is called electromechanical conversion, which deals with the conversion of electrical energy into mechanical energy or the opposite. Electric motors, generators, speakers, and transformers are just a few of the systems and gadgets we use every day that are based on this process. For engineers and scientists working in numerous areas, understanding the underlying concepts of electromechanical conversion is essential. The fundamental tenets of electromechanical conversion and their importance will be discussed in this essay.

**Electromagnetic Induction:** Michael Faraday developed electromagnetic induction in the 19th century, and it is one of the key concepts of electromechanical conversion. According to this theory, a conductor experiences an electromotive force (EMF) as a result of a fluctuating magnetic field. The passage of electrons within a conductor, such as a wire, causes the conductor to produce an electric current when it passes across magnetic field lines or encounters a changing magnetic field. Electric generators work on the basis of this concept, revolving a coil of wire in a magnetic field to transform mechanical energy into electrical energy.

**Magnetic Fields and Forces:** The interplay of magnetic fields and electric currents is another essential component of electromechanical conversion. A current-carrying conductor creates a magnetic field everywhere around it in accordance with Ampere's law. The magnetic field produced by a current-carrying coil causes mechanical motion or regulates the flow of current in a variety of electromechanical devices, including solenoids and relays. The force that a conductor carrying current experiences in a magnetic field is described by the Lorentz force equation. Electric motors' rotating motion and the movement of speaker diaphragms are both caused by this force.

**Electromechanical Transducers:** Devices that convert electrical energy into mechanical energy or the other way around are known as electromechanical transducers. A great illustration of an electromechanical transducer, which transforms electrical energy into mechanical energy, is an electric motor. They rely on the interplay of magnetic fields and electric currents to function. The motor shaft rotates when a current flows through a coil while it is in the presence of a magnetic field. Contrarily, machinery like buzzers and loudspeakers transform mechanical energy into electrical energy. An electrical signal is produced when a diaphragm is moved by an external mechanical force that interacts with a magnetic field.

**Efficiency of Energy Conversion:** When constructing and improving electromechanical systems, efficiency of energy conversion is a key factor. Efficiency, which is often stated as a percentage, is the ratio of input to output energy. The total efficiency of practical systems can be impacted by a number of elements, including mechanical friction, magnetic hysteresis, and resistive losses. By choosing the right materials, lowering electrical resistance, and enhancing the system's design and functionality, efficiency may be improved by minimizing these losses.

**Control and Regulation:** Electromechanical systems' control and regulation are essential for obtaining the intended functionality and performance. It is standard practice to use feedback control systems to regulate and stabilize electromechanical operations. These systems employ sensors to collect data on parameters like current, location, and speed, and compare it to predetermined reference values. The input electrical or mechanical parameters are then modified and controlled using the feedback signal to produce the desired output. Numerous applications, including robotics, automation, and power systems, make extensive use of this idea.

**Electromagnetism:** Electromechanical conversion and electromagnetism have many similarities. The interplay of magnetic fields and electric currents is referred to as electromagnetism. A magnetic field forms around a conductor as an electric current pass through it. This magnetic field's forces can cause neighboring conductors to move mechanically. The electric motor is one of the essential electromagnetism-based parts. A current-carrying conductor interacts with a stationary magnetic field to generate a magnetic field that causes mechanical rotation in an electric motor. To power different mechanical loads, like pumps, fans, and machines, this rotation is harnessed.

**Mechanical Work:** Another aspect influencing electromechanical conversion is mechanical work. It describes the use of force to move an object over a distance. Electric motors, which turn electrical energy into mechanical work, are frequently used in power systems to carry out mechanical work. Power input and application time have a direct impact on the quantity of work that is completed. In an electric motor, electrical energy is transformed into mechanical energy that rotates. The interaction between the magnetic fields created by the stator and the rotor causes a torque to be experienced by the motor's rotor, which is normally made up of coils or magnets. The rotor rotates as a result of this torque, producing mechanical work.

The ability to convert electrical energy into mechanical energy and vice versa is made possible by the fundamental engineering and scientific concept known as electromechanical conversion. It is based on ideas like electromagnetic induction, magnetic forces and fields, and how electromechanical transducers work. For the design, analysis, and optimization of electromechanical devices and systems, it is crucial to comprehend these concepts. As technology continues to evolve, electromechanical conversion will remain essential in sustaining our contemporary society and enabling a wide range of applications in several sectors[4]–[6].

## DISCUSSION

**Energy in Magnetic System:** Magnetic energy serves as a kind of energy storage in magnetic systems. The magnetic field's capacity to operate on magnetic materials or interact with other magnetic fields manifests itself as magnetic energy. Magnetic dipole alignment and arrangement as well as the flow of electric charges are both related to this energy. The magnetic energy in a system is affected by a number of variables, such as the magnetic characteristics of the materials involved, the strength of the magnetic field, and the arrangement of the magnetic system. The mathematical expression for the energy held in a magnetic field is:

$$E = (1/2) * \mu_0 * V * B^2$$

Where E is the magnetic energy,  $\mu_0$  is the permeability of free space, V is the volume of the magnetic field, and B is the magnetic field strength.

The magnetic dipoles within a magnetic substance, such as iron or a ferromagnetic material, align with the external field when the material is exposed to a magnetic field. The magnetic energy of the system is increased by this alignment. Magnetic hysteresis energy is a common name for the energy needed to magnetize or demagnetize a material. Magnetic systems are used in many modern gadgets and technology. Transformers, for instance, effectively move electrical energy between various voltage levels by using magnetic energy. A magnetic core is encircled by the primary and secondary coils of a transformer, allowing the magnetic field to create a voltage in the secondary coil. Magnetic energy is also used by electric motors to power them.



The torque created by the interplay of the magnetic fields produced by the stator and rotor is what propels the motor's revolution. Magnetic fields' existence and control enable the conversion of electrical energy into mechanical energy in motors. Information is stored and retrieved utilizing magnetic energy in magnetic storage devices like hard disk drives. Binary data is represented by tiny magnetic patches on the disk surface, with the direction of the magnetization standing for either a 0 or a 1.

For recording and reading data, the energy needed to alter the magnetic state of these locations is essential. It is significant to highlight that unlike other types of energy, such as electrical energy, magnetic energy is not frequently linked to losses. Most of the time, magnetic energy is preserved inside the system and is available for retrieval and use as needed. However, there may be some energy losses as a result of things like hysteresis, eddy currents, and resistance in conductive materials. Magnetic energy is the kind of energy that is held in a magnetic system. Magnetic dipole alignment and arrangement as well as the flow of electric charges are both related to this energy. Transformers, electric motors, and magnetic storage devices are a few examples of gadgets that use magnetic systems. These gadgets depend heavily on the manipulation and conversion of magnetic energy. The design and improvement of magnetic systems as well as their effective use in diverse technologies depend on an understanding of the fundamentals of magnetic energy.

**Field Energy:** The energy connected to a field, such as an electromagnetic field or a gravitational field, is referred to as field energy. Field energy is relevant to the storage and transmission of energy inside these fields in the context of electromechanical conversion. For instance, in electromagnetic systems, the electric and magnetic fields around conductors and magnets are where field energy is stored. In electrical systems, the field energy is either stored in the magnetic field produced by a current-carrying wire or in the electric field between charged particles. Through the interaction of the fields and the parts of the system, this stored energy may be transformed into other forms, such as mechanical energy.

**Mechanical Force:** The application of a force as a result of physical interaction between two things produces mechanical work or motion. Mechanical force is important in the electromechanical conversion process because it helps turn electrical energy into mechanical energy and vice versa. For instance, in electric motors, the interaction of the magnetic fields created by the stator and rotor results in a mechanical force that rotates the rotor. This mechanical force is used to propel machines or turn a generator, which transforms mechanical energy back into electrical energy, among other valuable tasks. Similar to this, in generators, the rotor is rotated within a magnetic field by applying a mechanical force, which is frequently delivered by an external source like a turbine. This mechanical force causes the stator windings to experience an electromotive force (EMF), which transforms mechanical energy into electrical energy. Overall, the electromechanical conversion process is based on the interplay of mechanical force and field energy. The fields that surround conductors or magnets contain field energy, and when these fields combine to create mechanical force, energy is transformed from electrical to mechanical forms.

**Multiple Excited Magnetic system:** Multiple magnetic fields interact to produce desired effects or functionalities in complicated electromechanical systems known as multiply-excited magnetic field systems. These systems generally comprise a number of electromagnets or permanent

magnets placed in particular arrangements to create a combined magnetic field with particular characteristics. Multiple fields, including electric power generation, magnetic levitation, magnetic resonance imaging (MRI), particle accelerators, and magnetic confinement fusion devices, use the notion of multiply-excited magnetic field systems. To accomplish certain goals, these systems frequently need to precisely manipulate the magnetic fields and their interactions. The electric generator used in power plants is one instance of a system with several excited magnetic fields. Electric generators are made up of a fixed stator with conducting coils and a spinning rotor with electromagnets. The conducting coils of the stator interact with the magnetic field created by the rotating rotor's electromagnets to produce electrical energy. The output voltage and power characteristics of the generator may be adjusted by adjusting how the electromagnets are excited.

Multiply-excited magnetic field systems are used in the field of magnetic levitation to generate stable levitation or suspension of items without any physical touch. To overcome gravitational forces, these devices make use of the attractive or repulsive interactions that exist between magnetic fields. The magnetic field produced by positioning permanent magnets or electromagnets in particular arrangements, such as Halbach arrays, can display a spatially shifting pattern that produces stable levitation or suspension of things. The usage of repeatedly excited magnetic field devices is also widespread in medical equipment like MRI scanners. A powerful and uniform magnetic field is necessary for MRI in order to align the nuclear spins of atoms inside the human body. For diagnostic reasons, this alignment enables the creation of detailed pictures. MRI systems use gradient coils and superconducting magnets to produce the precise magnetic field patterns required for imaging.

Multiplicatively excited magnetic field systems are also crucial components of particle accelerators, which are crucial instruments in high-energy physics research. These systems employ a number of magnets organized in certain patterns to quickly accelerate charged particles like protons or electrons. These magnets' magnetic fields interact to regulate the course and energy of the particles, allowing for experimentation and studies into the basic elements of matter. In magnetic confinement fusion devices like tokamaks, multiply-excited magnetic field systems are used in the search for usable fusion energy. The high-temperature plasma necessary for fusion reactions is contained and controlled in these devices using a mix of toroidal and poloidal magnetic fields. The stability and confinement of the plasma, which is essential for producing a sustained fusion reaction, are determined by the interplay between these magnetic fields. Multiply-excited magnetic field systems are intricate configurations of magnetic fields used in a variety of applications. They make it possible to produce electrical energy, conduct magnetic levitation experiments, use medical imaging, accelerate particles, and study fusion energy. These systems are exciting and significant areas of research and engineering because the accurate control and manipulation of these magnetic fields is essential for getting the required results in each application.

**Multiply-excited Magnetic Field System Principles:** The concept of superposition, which asserts that magnetic fields created by several sources may be combined to create a resultant magnetic field, underlies the operation of multiple-excited magnetic field systems. These systems can produce certain results that are not feasible with a single magnetic field by manipulating the separate magnetic fields and their interactions[7]–[9]. For instance, in electrical generators, multiple field windings are used in multiply-excited magnetic field systems

to produce a complicated magnetic field pattern inside the stator. This enables more effective power generation and greater management of the produced voltage.

### **Multiply-Excited Magnetic Field Systems Provide Advantages**

- a. Greater Control:** These systems provide greater control over the magnetic fields that are created by employing numerous magnetic fields, enabling exact modifications to fit particular needs. Efficiency in energy conversion and enhanced system performance are made possible by this degree of management.
- b. Increased Flexibility:** Multiply-excited magnetic field systems enable the production of magnetic fields with a variety of spatial distributions and inclinations. They are excellent for a variety of applications due to their adaptability, including high-power generators and specific scientific research.
- c. Increased Efficiency:** The capacity to customize the magnetic field distribution in these systems can result in an increase in the effectiveness of energy conversion and power production. Losses may be reduced and system efficiency raised by adjusting the magnetic field pattern.

Multiply-excited magnetic field systems applications:

- a. Electric Power Generation:** Multiply-excited magnetic field systems are frequently employed in the production of electric power. These systems allow for efficient and consistent energy production by managing the magnetic field distribution within generators. They are used in a variety of generating facilities, including wind, hydroelectric, and thermal ones.
- b. Motors and Actuators:** Electric motors and actuators both make use of multiplex-excited magnetic field systems. These systems allow for fine control of motor performance, including torque, speed, and efficiency, by employing numerous field windings. They are used in a variety of fields, including robotics, automotive systems, and industrial machines.
- c. Transformers:** To move electrical energy between various voltage levels, transformers use devices with multiplexed magnetic fields. The primary and secondary windings of a transformer's primary winding and secondary winding are controlled magnetic fields that allow for precise and effective voltage transformation. They are crucial elements of electricity distribution and transmission networks.
- d. Scientific Research:** In disciplines like plasma physics and particle accelerators, multi-excited magnetic field systems are very important. For the purpose of conducting high-energy physics experiments, these devices provide intricate magnetic field combinations for researching charged particle behavior and plasma confinement.

Systems with multiple excited magnetic fields provide improved control, adaptability, and efficiency. In order to combine different magnetic fields and accomplish certain goals, they make use of the superposition principle. These systems are used in scientific research, motors, transformers, and the production of electric power. Engineers and scientists may create and optimize systems that satisfy the many demands of contemporary technology and progress energy conversion and scientific research by taking use of the benefits of multiply-excited magnetic field systems.

**Forces/Torques in Systems with Permanent Magnets:** In many electromechanical systems, permanent magnets are essential for producing the forces and torques needed for motion and mechanical work. For permanent magnet systems to be designed, operated, and optimized, it is crucial to comprehend the forces and torques involved. The forces and torques in systems with permanent magnets are covered in this article in detail, along with the underlying theories, computations, and applications. Principles of Forces and Torques in Systems with Permanent Magnets: The interactions between magnetic fields and the laws of magnetism are what largely control the forces and torques in systems with permanent magnets. The Lorentz force, which asserts that a magnetic field exerts a force on a moving charged particle or current-carrying conductor, is the fundamental concept at play. Forces and torques are created in systems that contain permanent magnets as a result of the interaction between the permanent magnet's magnetic field and magnetic fields produced by other sources (such as electromagnets or other permanent magnets). Depending on the relative orientations of the magnetic fields and the magnetic characteristics of the materials involved, these forces and torques may be either attracting or repulsive. Forces and torques are calculated in systems with permanent magnets by taking into account a number of variables, such as the strength of the magnetic field, the geometry of the magnet arrangement, and the magnetic characteristics of the materials.

- a. **Magnetic Field Strength:** A permanent magnet's magnetic field strength is measured by its magnetic flux density, which is sometimes denoted by the letter "B." The magnetic field's strength determines the force or torque it produces.
- b. **Geometry:** The forces and torques are greatly influenced by the geometry of the magnet setup. The forces and torques that occur depend on variables such as the separation between magnets, their orientation, and the nature of the magnetic fields.
- c. **Magnetic characteristics:** The forces and torques in the system are influenced by the magnetic characteristics of the materials utilized, including the magnetic moment and magnetic susceptibility. Magnets of various kinds, such as ferrite magnets and neodymium magnets, have various magnetic characteristics.

Force and torque applications in systems using permanent magnets:

- a. **Electric Motors:** Permanent magnet motors, like brushless DC motors, use the stresses and torques produced by the magnetism of the permanent magnets to transform electrical energy into mechanical motion. The required torque for motor rotation is generated by the magnetic interaction between the stator and rotor.
- b. **Magnetic Levitation:** Magnetic levitation devices, such as magnetic bearings or maglev trains, require permanent magnets. To hang items or vehicles in a secure, non-contact position, magnets' repelling forces may be carefully regulated [10].
- c. **Magnetic Resonance Imaging (MRI):** For medical imaging, magnetic resonance imaging (MRI) equipment use strong magnetic fields produced by permanent magnets or superconducting magnets. The alignment of nuclear spins is manipulated by these magnets, allowing for precise imaging of the human body.
- d. **Magnetic Separation:** Permanent magnets are used in magnetic separation systems to distinguish between magnetic and non-magnetic materials. The magnets' magnetic fields may draw or resist the target materials, enabling quick separation procedures.

The operation and functioning of systems including permanent magnets depend critically on forces and torques. The design and optimization of several electromechanical systems, such as electric motors, magnetic levitation systems, MRI machines, and magnetic separation systems, are made possible by an understanding of the principles regulating these forces and torques. Engineers may develop creative approaches for effective energy conversion, accurate motion control, and magnetic manipulation in a variety of applications by utilizing the characteristics and interactions of permanent magnets.

## CONCLUSION

The effective conversion of electrical energy into mechanical energy and vice versa is made possible by electromechanical conversion, a crucial process in power systems. Understanding this conversion process requires knowledge of electromagnetism and electromagnetic induction concepts. Electric power generation, transmission, and use are made easier by a variety of parts, including generators, motors, transformers, and transmission lines, by applying these concepts. These electromechanical systems must be carefully designed, operated, and maintained in order to convert energy reliably and efficiently. A more dependable and sustainable energy future is also being paved over by improvements in technology and research, which are improving power system performance and sustainability.

## REFERENCES:

- [1] Z. U. Kocabiyikoğlu, “Principles of Electromechanical Energy Conversion,” in *Electromechanical Energy Conversion*, 2020. doi: 10.1201/9780429317637-3.
- [2] M. G. Say, “Principles of Electromechanical Energy Conversion,” *Electron. Power*, 1966, doi: 10.1049/ep.1966.0296.
- [3] T. Gonen, “Electromechanical Energy Conversion Principles,” in *Electrical Machines with MATLAB*, 2020. doi: 10.1201/b11685-10.
- [4] E. Lefeuvre, A. Badel, C. Richard, L. Petit, and D. Guyomar, “A comparison between several vibration-powered piezoelectric generators for standalone systems,” *Sensors Actuators, A Phys.*, 2006, doi: 10.1016/j.sna.2005.10.043.
- [5] B. Ma, J. Zheng, G. Lei, J. Zhu, P. Jin, and Y. Guo, “Topology Optimization of Ferromagnetic Components in Electrical Machines,” *IEEE Trans. Energy Convers.*, 2020, doi: 10.1109/TEC.2019.2960519.
- [6] P. Martins, D. M. Correia, V. Correia, and S. Lanceros-Mendez, “Polymer-based actuators: back to the future,” *Physical Chemistry Chemical Physics*. 2020. doi: 10.1039/d0cp02436h.
- [7] M. I. Yuce and A. Muratoglu, “Hydrokinetic energy conversion systems: A technology status review,” *Renewable and Sustainable Energy Reviews*. 2015. doi: 10.1016/j.rser.2014.10.037.
- [8] R. P. Magisetty and N. S. Cheekuramelli, “Additive manufacturing technology empowered complex electromechanical energy conversion devices and transformers,” *Applied Materials Today*. 2019. doi: 10.1016/j.apmt.2018.11.004.
- [9] K. Xie, D. Li, R. Qu, X. Ren, M. R. Shah, and Y. Pan, “A New Perspective on the PM



Vernier Machine Mechanism,” *IEEE Trans. Ind. Appl.*, 2019, doi: 10.1109/TIA.2018.2880144.

- [10] K. Di *et al.*, “Dielectric elastomer generator for electromechanical energy conversion: A mini review,” *Sustain.*, 2021, doi: 10.3390/su13179881.

## BASIC CONCEPTS IN ROTATING MACHINES

**Mr. Bishakh Paul\***

\*Assistant Professor,  
Department of Electrical And Electronics Engineering,  
Presidency University, Bangalore, INDIA  
Email Id-bishakhpaul@presidencyuniversity.in

---

### ABSTRACT:

*In power systems, rotating machines are essential for converting electrical energy to mechanical energy or the other way around. Rotating machines are essential parts of power systems that convert mechanical energy into electrical energy or the other way around. This chapter seeks to give a thorough explanation of the fundamental ideas surrounding spinning machines in power systems. It discusses numerous rotating machine types, their operating theories, and the crucial factors that affect their performance. The key ideas covered in the study are summarized in the chapter.*

**KEYWORDS:** *Mechanical Energy, Magnetic Flux Leakage, Rotating Machines, Rotating Magnetic Field.*

---

### INTRODUCTION

They are extensively utilized in the production, transmission, and distribution of power. This article will examine the kinds, operating concepts, and uses of rotating machines in power systems. Rotating machines are electromechanical devices made up of a stator, which is a fixed component, and a rotor, which is a rotating component. The winding or coils are contained in the stator, whilst the magnetic field is carried by the rotor. The rotor rotates when the stator receives electrical energy because the rotating magnetic field it generates interacts with the rotor and causes it to revolve. It is possible to create electrical energy or transform electrical energy into mechanical energy by using this circular motion. Generators and motors are the two primary categories of rotating devices utilized in power systems. While motors turn electrical energy into mechanical energy, generators change mechanical energy into electrical energy. Both types work according to the same underlying principles, although they do so in different ways. Power facilities that generate substantial amounts of electricity must have generators. They may be powered by steam turbines, gas turbines, or hydro turbines, among other power plants.

A voltage is induced in the stator windings when the rotor of a generator is spun by a prime mover, such as a turbine, thanks to electromagnetic induction. After that, this voltage is changed and transported over power lines to supply users with electricity. On the other hand, motors have many different uses, including in appliances, transportation systems, industrial machines, and more. A motor's stator windings receive electrical energy, which causes a spinning magnetic field to be created. The rotor rotates and performs mechanical work due to the interaction between this magnetic field and the rotor. For driving pumps, compressors, fans, conveyor belts, and other mechanical equipment, motors are essential[1]–[3].

Power systems may benefit from rotating machinery in a number of ways. They first offer a versatile and effective way to transform energy from one form to another. They are highly efficient in converting enormous amounts of electrical energy into mechanical energy or the other way around. They are therefore essential for supplying the energy needs of diverse businesses and families. Second, rotating equipment helps maintain the dependability and stability of a system. For example, generators are essential for keeping the frequency and voltage levels within reasonable bounds. By modifying their output according on system conditions, they aid in balancing the power demand and supply in a grid.

On the other side, motors make it possible to automate and regulate industrial operations, increasing production and efficiency. Additionally, the intrinsic inertia of spinning equipment ensures system stability during transient occurrences like failures or abrupt load fluctuations. This inertia contributes to the stability of the system and avoids abrupt changes in frequency or voltage. To sum up, spinning machines are essential parts of power systems. They are essential for the generation, transmission, and use of power because they allow the conversion of electrical energy to mechanical energy and vice versa. Large-scale power is produced by generators, and a variety of mechanical devices are driven by motors. In order to fulfill the energy needs of businesses and homes, this equipment help power systems remain stable, dependable, and efficient. Rotating machines will continue to develop and play an important part in the future of power systems as a result of continued improvements.

Rotating machines, which convert mechanical energy into electrical energy and vice versa, are essential parts of power systems. This essay has given a thorough explanation of the fundamental ideas pertaining to spinning machines. The fundamentals of electromagnetic induction and electromagnetism were highlighted when they were explored in relation to the workings of generators and motors. Additionally, it addressed a range of rotating machine types, including transformers, synchronous generators, DC motors, and induction motors, as well as their uses. In assessing the performance of rotating machines, the significance of important performance criteria such as efficiency, power factor, torque, and speed was highlighted. To guarantee effective and dependable operation, engineers and other professionals working in the field of power systems must understand these fundamental ideas and performance criteria. To fulfill the changing needs of contemporary power systems, rotating machine technology research and development must continue.

**Working principle of Rotating Machine:**Electromagnetism and electromagnetic induction are the fundamental concepts that underpin the operation of rotating machinery. While electrical energy is transformed into mechanical energy in motors, mechanical energy is transformed into electrical energy in generators.The interplay of magnetic fields and electric currents, which results in the conversion of electrical energy to mechanical energy or vice versa, provides the basis for the operation of spinning machines. The stator and the rotor are a spinning machine's two primary parts. The machine's stator, which is immovable, is made up of a number of coils or windings. To produce a magnetic field, these windings which are commonly constructed of copper or aluminum are organized in a certain configuration. A battery or an electrical grid are often used as the external power sources for the stator windings.

The machine's rotating component, the rotor, is in charge of creating or reacting to the magnetic field that the stator produces. Depending on the kind of spinning machine, the rotor may be

either an electromagnet or a permanent magnet. A magnetic field is produced around the stator windings when an electrical current flows through them. This magnetic field's structure and properties depend on how the windings are arranged. An alternating current (AC) machine produces a spinning magnetic field when the current periodically reverses direction. The rotor is affected by the stator's rotating magnetic field. In the instance of a generator, electromagnetic induction causes a voltage to be induced in the rotor windings as a result of the relative motion between the spinning magnetic field and the rotor. The rotor generates this voltage, which may be utilized as an output. In essence, mechanical energy is changed into electrical energy by the rotation of a turbine, for example.

In contrast, a motor's rotor receives electrical current, which generates a magnetic field. The rotor rotates as a result of the interaction between this magnetic field and the stator's spinning magnetic field. In turn, mechanical energy, which can be employed to drive motion, is created from electrical energy. The design of the windings, the type of magnetic materials employed, the regulation of electrical current, and the mechanical load supplied to the rotor are some of the variables that affect a spinning machine's efficiency and performance. These variables may be changed to regulate and optimize the machine's speed, torque, and power output for certain purposes. The generation of a magnetic field in the stator, which interacts with the rotor to produce or respond to the magnetic field, is essential to the operation of a spinning machine. Electrical energy is converted into mechanical energy in the case of motors or mechanical energy is converted into electrical energy in the case of generators as a result of this interaction.

**Generated E.M.F:** The abbreviation EMF stands for Electromotive Force, which describes the voltage or electrical potential difference produced in a spinning machine. The EMF in a generator is the voltage that is induced in the rotor windings as a result of the interaction between the spinning magnetic field that is created by the stator and the rotor. The machine's design, the machine's rotational speed, the intensity of the magnetic field, and the number of turns in the rotor windings are just a few of the variables that affect the amplitude and waveform of the EMF that is created. Faraday's rule of electromagnetic induction explains how these variables interact to produce an EMF. According to Faraday's law, an EMF is created in the conductor whenever there is a relative motion between a magnetic field and the conductor. In the case of a generator, the magnetic lines of force cross the rotor windings as the rotor rotates in the magnetic field created by the stator. The rotor windings experience a voltage as a result of this relative motion.

The pace at which the magnetic field lines pass the rotor windings determines the strength of the induced EMF. The rotor's rotational speed, the intensity of the magnetic field, and the number of turns in the rotor windings all have an impact on this rate of change. A higher induced EMF is produced by faster speeds, more powerful magnetic fields, and more winding turns on the rotor. Depending on the kind of spinning machine, the EMF's waveform varies. The induced EMF from an AC generator follows an AC waveform, often a sinusoidal waveform. The generator's rotating speed and the frequency of the AC waveform are intimately correlated. In contrast, a DC generator uses commutation to transform the generated EMF into a direct current (DC) waveform. It's crucial to remember that other elements like as the load attached to the machine, the excitation current, and the machine's design parameters all affect the produced EMF in a spinning machine. The strength and stability of the produced EMF can be impacted by several elements. Overall, the produced EMF in a spinning machine is an important factor since it affects the machine's performance and determines the electrical output of a generator. It is

possible to maximize the output and efficiency of the spinning machine by managing the elements that influence the EMF produced, such as speed, magnetic field intensity, and winding design[4]–[6].

## DISCUSSION

**Types of Rotating Machines:** Different rotating machine types are employed in diverse power system applications. The primary kinds consist of:

- 1. Synchronous Generators:** In order to produce energy, synchronous generators are frequently employed in power plants. They generate AC electricity at a set frequency while running at a steady speed. The term "synchronous generator" refers to a spinning magnetic field in the rotor that synchronizes with the magnetic field in the stator. These generators frequently work in tandem with primary mover units like gas, steam, or hydro turbines.
- 2. Induction generators:** Especially in wind turbines, induction generators are often utilized in renewable energy systems. They move at varying speeds since they are asynchronous machinery. An induction generator's rotor is powered by the mechanical energy of the turbine and is not linked to any external power source. Induction generators are renowned for being straightforward, dependable, and able to function under a variety of wind situations.
- 3. DC Generators:** Direct current (DC) is produced by DC generators, commonly known as dynamos. The AC voltage induced in the rotor windings is normally converted to a DC voltage using a commutator and brushes. Early power systems made extensive use of DC generators, and these devices are still utilized today for a variety of purposes, including traction motors and battery charging systems.
- 4. Synchronous Motors:** Synchronous motors are similar to synchronous generators in terms of structure; however, they function as motors as opposed to generators. They are frequently utilized in industrial settings where exact speed control is necessary. Because they may run at a leading power factor, synchronous motors are well suited for power factor correction in power systems.
- 5. Induction Motors:** The most popular form of motor utilized in a variety of applications, from industrial gear to home appliances, is an induction motor. They are durable, dependable, and economical. Induction motors work by inducing currents in the rotor through the stator's spinning magnetic field, which produces a torque and rotates the rotor.
- 6. Brushless DC Motors:** Due to its high efficiency, little maintenance needs, and accurate control, brushless DC (BLDC) motors are gaining popularity. Instead of using brushes and commutators, these motors employ electronic commutation. Applications for BLDC motors include robots, computer cooling fans, and electric vehicles.
- 7. Stepper Motors:** Stepper motors are specialized motors that are made to revolve in precise steps or increments. They are frequently employed in devices like 3D printers, CNC machines, and robotics that need accurate positioning. Stepper motors work by sequentially activating particular coils, which causes the rotor to rotate progressively.

These are some of the most common rotating machine types found in diverse applications and power systems. Each kind is distinct in its advantages, benefits, and acceptable uses, making them adaptable parts of contemporary power systems.



**Key Performance Parameters of Rotating Machines:** To assess and guarantee the efficient and dependable functioning of rotating devices like motors and generators, critical performance metrics are crucial. These variables consist of:

- 1. Power Rating:** A rotating machine's power rating tells you how much power it can produce or manage at its maximum. It is often stated in kW or MW and indicates how well a machine can manage or convert electrical or mechanical power.
- 2. Efficiency:** Efficiency evaluates how well a spinning machine converts input power into output power, and it is a critical performance characteristic. The ratio of output power to input power, taking into account machine losses and inefficiencies, is given as a percentage. Increased efficiency translates into improved energy conversion and lower energy losses.
- 3. Power Factor:** The ratio of real power to apparent power is known as the power factor. It displays how well an AC spinning machine uses power. The machine is said to be using power efficiently if the power factor is 1 or unity power factor, whereas a power factor of less than 1 denotes reactive power use and system inefficiency.
- 4. Voltage Regulation:** The capacity of a generator to maintain a constant voltage output despite fluctuations in the associated load is known as voltage regulation. It is the difference between the voltages at no load and full load divided by the full load voltage, and it is given as a percentage. Lower voltage regulation denotes improved output voltage stability performance.
- 5. Speed Control:** The capacity of a spinning machine, particularly a motor, to maintain a comparatively constant speed despite changes in the mechanical load is known as speed control. It is the difference between the no-load and full-load speeds divided by the full-load speeds, and it is stated as a percentage. Lower speed regulation denotes improved ability to keep a steady speed.
- 6. Starting Torque:** The torque produced by a motor at startup to overcome the inertia and resistance of the load is known as starting torque. It is a crucial variable, particularly in situations when the motor must start while carrying high weights. More beginning torque guarantees that the motor can start moving smoothly and effectively.
- 7. Temperature Rise:** The term "temperature rise" describes the rise in temperature that occurs within a spinning machine when it is operating normally. In order to avoid overheating and guarantee the machine's dependability and lifetime, it is essential to monitor and regulate the temperature. Increased temperature can cause insulation to deteriorate, systems to perform less effectively, and even cause breakdowns.
- 8. Mechanical Vibration and Noise:** Vibration and noise levels are crucial factors to take into account in rotating machines, especially for applications that call for low vibration and noise levels. The performance, dependability, and overall system operation of the machine may be impacted by excessive vibration and noise, which may be an indication of mechanical imbalances, misalignments, or bearing problems.

In determining the acceptability, effectiveness, and dependability of rotating machines in power systems and other applications, several essential performance metrics are crucial. Manufacturers frequently offer specifications for these factors, enabling customers to choose the best equipment

for their unique needs. The machines must also be regularly inspected and maintained to guarantee that they satisfy these performance standards throughout the duration of their operating lives.

**Rotating Magnetic Field:** An essential element in the operation of spinning machinery like motors and generators is a rotating magnetic field. Within the machine, a magnetic field circulates in a circular or elliptical pattern. The interplay of the stator windings and the electrical current running through them produces the spinning magnetic field. The configuration of the stator windings is the basis of the theory underlying the generation of a spinning magnetic field. The stator windings are often placed in a certain configuration known as a three-phase winding in a three-phase system. The angle that separates each phase winding from the others is normally 120 degrees. These windings produce an alternating magnetic field that changes in strength and direction when three-phase alternating current (AC) is supplied to them. Each stator winding produces a magnetic field when the three-phase AC current passes through them. The resultant magnetic field spins in a circular or elliptical pattern as a result of the interaction of these magnetic fields. The order of the phases and the current flowing through the windings determine the direction of rotation. The rotating magnetic field has a number of significant qualities and benefits, including:

1. **Flux Density:** The magnetic flux density is kept mostly constant across the air gap between the stator and the rotor by the spinning magnetic field. This magnetic field's homogeneous distribution decreases losses while enabling effective energy conversion.
2. **Induction:** In generators, the electromagnetic induction of the rotating magnetic field causes a voltage to be induced in the rotor windings. The output of this voltage is then used to be collected. In motors, the rotor rotates due to the torque produced by the interaction between the rotating magnetic field and the rotor windings.
3. **Synchronous operation:** In synchronous machines (generators and motors), the rotating magnetic field synchronizes with the frequency of the AC power system. This synchronization enables motors to run at a specified speed set by the frequency and enables generators to supply power to the grid at the required frequency.
4. **Efficiency:** The power conversion between electrical and mechanical energy is guaranteed by the rotating magnetic field. The machine may better couple with the rotor by creating a smooth, rotating magnetic field, which lowers losses and boosts overall effectiveness.

Understanding how rotating magnetic fields work is essential for comprehending how spinning machines function. It makes it possible for electrical energy to be converted into mechanical energy in motors and for mechanical energy to be converted into electrical energy in generators. The performance, effectiveness, and stability of spinning machines may be adjusted for a variety of applications by adjusting the structure and properties of the rotating magnetic field.

**Operation of Basic Machine Types:** Generators and motors are two examples of the primary machine types utilized in power systems. These machine type's function using various concepts and methods. Here is a description of how each machine type works[7]–[9]:

#### **Synchronous Power Plants:**

1. A synchronous generator's stator windings are coupled to an outside AC power source.

2. A spinning magnetic field is produced when the stator windings receive AC electricity.
3. A magnetic field is produced by a DC current stimulated by the rotor's field windings.
4. The rotating magnetic field of the stator and that of the rotor are synchronized.
5. The rotor windings experience a voltage as a result of the interaction between the two magnetic fields.
6. As the generator's output, this induced voltage is gathered and sent to the power grid.

### **Induction Generators**

1. The electromagnetic induction theory underlies the operation of induction generators.
2. An AC power supply is linked to an induction generator's stator windings.
3. A rotating magnetic field is created as the stator windings receive AC electricity.
4. The conductive bars or cages that make up the rotor are not directly coupled to an outside power source.
5. A magnetic field is produced by the rotor's currents being induced by the rotating magnetic field.
6. The rotor rotates as a result of the torque produced by the magnetic fields of the rotating stator and the rotor.
7. In wind turbines, where the rotor is propelled by the mechanical energy of the wind, induction generators are frequently utilized.

### **DC Generators**

1. DC generators work using the electromagnetic induction principle and a commutator.
2. To produce a static magnetic field, the stator has field windings or permanent magnets.
3. Armature windings are found on the rotor, which is coupled to an outside mechanical power source.
4. The armature windings cross the magnetic field as the rotor turns, producing a voltage.
5. Direct current (DC) output voltage is maintained by the commutator and brushes.
6. The commutator and brushes provide a DC output voltage that is gathered for use in a variety of applications.

### **Synchronous Motors:**

1. Synchronous motors work in reverse, but otherwise similarly to synchronous generators.
2. An AC power supply is linked to the stator windings, generating a rotating magnetic field.
3. Using a DC current, the rotor's field windings are stimulated.
4. The rotor rotates as a result of an interaction between the rotating magnetic field of the stator and the magnetic field of the rotor.

5. Synchronous motors are frequently utilized in activities like industrial processes and electric propulsion systems where precise speed control is needed.

### Induction Motors

1. The principles of electromagnetic induction and the rotating magnetic field underlie the operation of induction motors.
2. An AC power supply is linked to the stator windings, creating a rotating magnetic field.
3. The rotor, which is ordinarily a squirrel cage rotor with conductive bars, isn't directly wired into a power supply.
4. A magnetic field is produced by currents being induced by the spinning magnetic field in the rotor bars.
5. The rotor rotates as a result of the torque produced by the interaction between the rotating magnetic fields of the stator and the rotor.

Because of their efficiency, dependability, and simplicity, induction motors are often employed in a wide range of applications. These fundamental machine types each have unique benefits, drawbacks, and uses. The best machine type for a certain power system or application may be chosen by being aware of how they operate.

**Magnetic Leakage in Rotating Machines:** The occurrence where the magnetic flux produced by the stator windings does not entirely link with the rotor is known as magnetic leakage in rotating machines. Instead, a part of the magnetic flux travels through the air or other non-magnetic objects and skips the rotor entirely. The operation and design of spinning machines may need to take into account a variety of impacts and factors as a result of this magnetic flux leakage. Following are some essential details about magnetic leakage in spinning machines:

**Magnetic Flux Path:** In a perfect world, the rotor would be passed through by the magnetic flux generated by the stator windings, producing the required voltage or torque. However, some flux deviates from the intended direction and leaks into the surrounding air or other non-magnetic components due to several reasons including machine design, manufacturing errors, and magnetic saturation.

**Magnetic Flux Leakage Effects:** Effects of Magnetic Flux Leakage Magnetic flux leakage may have the following effects on the functionality of spinning machines:

- a. **Reduced Efficiency:** Due to magnetic flux leakage, some of the produced flux is lost and not actively used to convert energy. As the leakage flux does not contribute to the intended output or torque, this may lead to decreased efficiency.
- b. **Higher Losses:** The neighbouring conducting and magnetic materials are subjected to eddy currents and hysteresis losses caused by the leakage flux, which results in higher losses and decreased overall efficiency.
- c. **Distorted Magnetic Fields:** Magnetic leakage changes how the magnetic field is distributed inside the machine, resulting in a non-uniform intensity of the magnetic field and unequal torque or voltage generation.

- d. Increased Heating:** Magnetic leakage can cause localized hotspots and increased heating in certain areas of the equipment, which can reduce its dependability and shorten its lifespan.
- e. Leakage Reactance:** The leakage reactance may be used to calculate the magnetic leakage in spinning equipment. The inductive reactance connected to the magnetic flux that avoids the rotor is represented by leakage reactance. It affects the machine's electrical properties, such as voltage regulation and transient responsiveness, and performance traits [10].

**Mitigation Techniques:** Design professionals and engineers use a variety of mitigation strategies to lessen the consequences of magnetic leakage in spinning equipment.

- a. Improved Core and Winding Design:** A better core and winding design can reduce magnetic leakage and improve the flux connection between the stator and rotor.
- b. Magnetic Shielding:** By rerouting or containing the leakage flux, magnetic shielding materials can lessen their effects on neighbouring components or sensitive locations.
- c. Increased Air Gap:** Increasing the air gap between the stator and rotor can minimize flux leakage and enhance magnetic coupling in general.
- d. Finite Element Analysis (FEA):** By simulating and analysing the magnetic fields within rotating machines, advanced computational tools, such as FEA, allow designers to optimize the machine's design to reduce magnetic leakage.

Rotating machines naturally exhibit magnetic leakage, and its effects should be taken into account while designing, running, and assessing these machines' performance. Engineers may enhance the effectiveness, performance, and dependability of spinning machines in power systems and other applications by comprehending and treating magnetic leakage.

**Losses and Efficiency of Rotating Machines:** In spinning machines, "losses" refer to the energy lost or squandered while they are in operation. The effectiveness and performance of the equipment may be considerably impacted by these losses. The primary categories of losses in rotating machines and how they affect efficiency are as follows:

**Copper Losses:** The resistance of the conductors causes copper losses in the stator and rotor windings of spinning machinery. Due to the copper conductors' resistance, some electrical energy that passes through the windings is transformed into heat. By utilizing bigger conductors or materials with lower resistivity, copper losses which rise with the square of the current can be minimized. It's critical to reduce copper losses if you want to increase the effectiveness of spinning machinery.

**Iron Core Losses:** The magnetic core of the stator and rotor experiences iron core losses, sometimes referred to as core losses or iron losses. Hysteresis and eddy currents in the core material cause these losses. The core's magnetization and demagnetization when the magnetic field changes cause hysteresis losses. Circulating currents that are induced in the core by the shifting magnetic field are the cause of eddy current losses. Utilizing materials with minimal hysteresis and eddy current losses or utilizing high-quality laminated iron cores are two ways to reduce core losses.

**Mechanical Losses:** In rotating machines, mechanical losses are linked to mechanical parts like bearings, gears, and brushes (in DC machines). The causes of these losses include friction and



windage. While windage losses are caused by air resistance to spinning parts, friction losses are caused by the contact of moving parts. Mechanical losses can be reduced and efficiency can be increased by the use of appropriate lubrication, effective bearing designs, and simplified machine casings.

**Stray Load Losses:** Magnetic flux leakage causes stray load losses, sometimes referred to as stray losses or leakage losses, to develop in the magnetic circuit of spinning machinery. As was previously mentioned, magnetic flux leakage can cause localized eddy current losses and uneven magnetic fields. Optimizing design and shielding methods can assist lower stray load losses and boost effectiveness by minimizing magnetic leakage.

Efficiency, which is measured as the ratio of usable power output to total power input, is a crucial performance characteristic for spinning machinery. The different losses mentioned above must be reduced to the absolute minimum in order to enhance efficiency. Rotating machines' efficiency is sometimes represented as a percentage and is affected by a variety of variables, including design, materials, operating circumstances, and manufacturing quality. There are various ways to increase efficiency, including:

1. To cut down on copper losses, use high-grade, low-resistivity conductors in windings.
2. Using low hysteresis and eddy current losses high-grade laminated iron cores.
3. Enhancing machine design to reduce stray load losses and magnetic leakage.
4. Utilizing effective bearing systems, as well as minimizing mechanical losses through appropriate lubrication and simplified designs.

In general, strengthening rotating machines' performance, lowering their energy requirements, and decreasing running expenses are essential for a variety of applications, from power production to industrial operations.

**Rating and Loss Dissipation:** When assessing the effectiveness and potential of rotating machines, rating and loss dissipation are two critical factors to take into account.

**1. Rating:** A rotating machine's rating describes its defined capacity or ability to manage a specific amount of power. The rating, which is determined by elements including the machine's size, design, and construction, is often represented in terms of power input or output. In order to choose the best equipment for a certain application, the rating offers information about the machine's maximum power handling capacity. The rating of a generator describes how much electrical power it is capable of producing and delivering to a load or a power grid. Typically, it is measured in kW or MW, or kilowatts. The rating considers things like the generator's effectiveness, cooling capacity, and mechanical restrictions. The rating of a motor describes how much mechanical power it is capable of dispensing to a load. It often refers to the motor's capacity to move a particular load under specific operating circumstances and is stated in kW or HP. Efficiency, starting torque, speed control, and temperature constraints are all taken into account while determining the motor rating.

**2. Loss Dissipation:** Loss dissipation is the term used to describe the amount of energy lost or squandered during the operation of a spinning machine. These losses happen for a variety of reasons, including mechanical, magnetic core, and winding resistive losses.

As previously established, mechanical, copper, iron, and stray load losses are the four basic categories of losses in rotating machinery. Due to these losses, electrical or mechanical energy is transformed into heat, which needs to be dissipated in order to keep the machine's operating temperature within reasonable bounds. In order to avoid excessive heating and to guarantee the dependability and lifetime of the equipment, efficient loss dissipation is essential. The heat produced by the losses is removed using the right cooling techniques, such as air or liquid cooling systems, to keep the equipment within its thermal boundaries. Loss dissipation has an impact on the machine's overall effectiveness as well. Lower efficiency is the result of higher losses because more input power is lost as heat. In order to increase the effectiveness and performance of spinning machines, it is crucial to minimize losses through ideal design, the selection of high-quality materials, and effective cooling techniques. In order to choose the best rotating machine for a certain application, evaluate its performance potential, and ensure its dependable and effective operation, it is crucial to understand the rating and loss dissipation characteristics of rotating machines.

## CONCLUSION

The basic principles of rotating machines in power systems have been introduced in this study. We've spoken about the many kinds of spinning machinery, such as motors and generators, as well as how they work. Furthermore, significant variables including efficiency, power factor, torque, and speed have been emphasized as being critical elements in assessing the performance of rotating machines. To guarantee effective and dependable functioning, engineers and other professionals working in the field of power systems must understand these fundamental ideas. To address the changing requirements of contemporary power systems, further investigation and developments in rotating machine technologies are required.

## REFERENCES:

- [1] X. Huang, W. Yang, Y. Li, B. Qiu, Q. Guo, and L. Zhuqing, "Review on the sensitization of turbulence models to rotation/curvature and the application to rotating machinery," *Appl. Math. Comput.*, 2019, doi: 10.1016/j.amc.2018.08.027.
- [2] F. Kielmann and M. Kaufhold, "Evaluation analysis of thermal ageing in insulation systems of electrical machines - A historical review - A h," *IEEE Trans. Dielectr. Electr. Insul.*, 2010, doi: 10.1109/TDEI.2010.5595538.
- [3] Y. Lei, *Intelligent fault diagnosis and remaining useful life prediction of rotating machinery*. 2016. doi: 10.1016/c2016-0-00367-4.
- [4] F. Li, W. Hua, M. Cheng, and G. Zhang, "Analysis of fault tolerant control for a nine-phase flux-switching permanent magnet machine," *IEEE Trans. Magn.*, 2014, doi: 10.1109/TMAG.2014.2325060.
- [5] K. C. Gryllias and I. A. Antoniadis, "A Support Vector Machine approach based on physical model training for rolling element bearing fault detection in industrial environments," *Eng. Appl. Artif. Intell.*, 2012, doi: 10.1016/j.engappai.2011.09.010.
- [6] M. Knez, S. Glode, M. Ruika, and J. Kramberger, "A rotating bending approach for determination of low-cycle fatigue parameters," *Int. J. Fatigue*, 2010, doi: 10.1016/j.ijfatigue.2010.03.014.

- [7] S. Ali, M. Hamza Tahir, M. Asad Saeed, M. Kashif Khan, and N. Zaffar, "Design and Development of Fatigue Machine: Rotating Bending Fatigue Testing on different Materials," 2019.
- [8] C. Heron, "Quantifying rotor condition in synchronous machines: Tools and methodologies," *IEEE Ind. Appl. Mag.*, 2020, doi: 10.1109/MIAS.2020.2981097.
- [9] R. T. Smith, "Electromagnetic and electromechanical machines," *J. Franklin Inst.*, 1973, doi: 10.1016/0016-0032(73)90063-x.
- [10] K. Reeser, C. Conlon, and A. L. Doiron, "Triangle mesh slicing and contour construction for three-dimensional printing on a rotating mandrel," *arXiv*, 2019.

## AC ARMATURE WINDINGS:DESIGN AND ANALYSIS TECHNIQUES

Mr. Veerappa Ravi\*

\*Assistant Professor

Department of Electrical And Electronics Engineering,  
Presidency University, Bangalore, INDIA  
Email Id-raviangadi@presidencyuniversity.in

---

### ABSTRACT:

*An integral part of alternating current (AC) equipment, such as generators and motors, are AC armature windings. They are essential for transforming mechanical energy from electrical energy and vice versa. An overview of AC armature windings, including their varieties, construction, and operating principles, is provided in this chapter. Understanding armature windings' essential features and the role they play in the effective operation of AC machines is the main goal. In order to attain the necessary performance characteristics, many design factors and optimization strategies are also covered, emphasizing the need of choosing the right winding configurations. The chapter tries to offer a succinct description of the chapter's arguments and their applicability to AC machines.*

**KEYWORDS:** *Ac Armature Winding, Armature Winding, Double Layer Winding, Lap Winding, Wave Winding.*

---

### INTRODUCTION

The field windings are straightforward configurations with focused coils, or coils where every turn has the same magnetic axis. On the other hand, armature windings are a collection of coils inserted into the slots and evenly distributed around the armature perimeter. Because of their relative motion to the B-wave in the air-gap created by the field windings, the armature coils experience emfs. An ac machine has three balanced phases (equal emf magnitudes with a relative phase displacement of  $2\pi/3$  rad) thanks to the symmetrical connection of the armature coils. To provide a constant (dc) voltage between brushes in a DC machine, the armature coils are connected through commutator segments that are tapped by stationary brushes. The same number of alternating poles for which the armature winding is coiled are established when it carries current, as was previously demonstrated.

A coil can be multitier with two coil sides made up of several conductors, or it can be single-turn with two conductors with end connections. The armature length (across which the flux density is established) matches the active coil side length in which the emf is induced. The electrical angle between a coil's two sides, known as the pitch, must equal an integral number of slots. There are two options for coil pitch complete equivalent to one pole pitch or  $180^\circ$  elect. or short-pitch coils. A coil's pitch can be described in terms of either its angular span or its slots. For a full-pitch coil, the slots/pole must be an integral number [1]–[3]. Practically speaking, there are two different types of windings: single-layer and double-layer. Each coil side of a coil fills the whole slot in a single-layer winding, as seen in Figure 1(a). According to Figure 1(b), in a double-layer winding, the first coil-side of a coil occupies the higher position in one slot, and the second coil-

side occupies the lower position in a slot that is separated from the first coil-side by the coil-span. Each slot in a double-layer winding is occupied by two coil-sides, known as the top and bottom coil-sides, which are stacked one on top of the other.

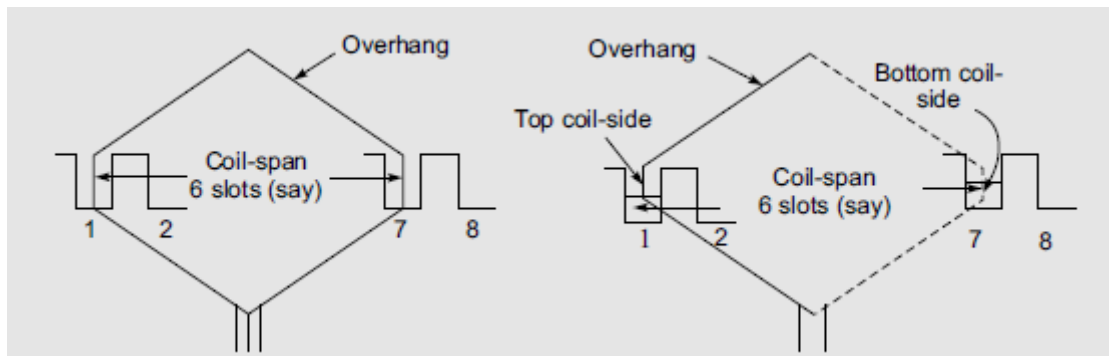

**Figure 1: (a) Single-layer coil, (b) Double-layer coil bottom coil side is shown dotted [EEE Guide].**

**AC Armature Winding:** An electric motor's AC armature winding is an essential part that transforms electrical energy into mechanical energy. It is in charge of producing the spinning magnetic field required for the motor to function. We shall examine the many forms, structures, and applications of AC armature winding in electric motors in this article. Multiple coils of wire are twisted around the armature core to create an AC armature winding. Laminated iron is commonly used for the armature core, which reduces eddy current losses. To achieve a balanced distribution of magnetic flux, the coils are equally spaced and placed in slots on the core. Lap winding and wave winding are the two main forms of AC armature winding. In lap winding, a parallel circuit is created by connecting the beginning of one coil to the end of the subsequent coil. Applications requiring low voltage and high current, such as traction motors, frequently employ this kind of winding.

However, in a series circuit, wave winding joins the start of one coil to the end of the following coil. For high-voltage, low-current applications like generators, wave winding is appropriate. The process of building an AC armature winding is multi-step. To reduce energy losses, thin iron sheets are first stacked and laminated to create the armature core. Then, to make room for the coils, the slots are meticulously carved or milled into the core. To electrically separate the coils from the core and adjacent coils, insulation materials are put into the slots. Copper wire that has a high conductivity is used to make the coils themselves. In order to increase insulation and avoid short circuits, the wire is frequently coated with enamel or a similar material. The exact requirements for the motor design, such as the voltage, current, and power rating, determine the size and form of the wire. The wire is initially inserted into the first slot, then it is wound around the core to begin winding. As the wire is moved through each slot, it coils up and fills them all. Until all necessary coils are coiled, the operation is repeated. The connecting of the coils to complete the circuit is determined by the winding pattern, whether lap or wave.

The coil ends are pulled out through access holes or terminals for connections to external electrical systems when winding is finished. Depending on the motor design, these ends, known as leads, are often attached to slip rings or a commutator. The electrical connection between the



armature winding and the external circuitry is made possible by the commutator or slip rings. Electric motors' AC armature winding is a crucial part since it contributes significantly to creating the magnetic field necessary for motor operation. A magnetic field is created when an alternating current passes through the armature winding. This magnetic field interacts with the magnetic field of the stator to produce rotational motion. The motor's performance, efficiency, and torque characteristics are influenced by the winding design, which includes the number of coils, wire gauge, and winding pattern. Finally, it should be noted that AC armature winding is a crucial component of electric motors. The motor's performance qualities are determined by its manufacture and design. Engineers may maximize motor efficiency, torque production, and overall dependability by carefully choosing the winding type, wire gauge, and connecting arrangement. Designing and producing effective and dependable electric motors for a variety of applications requires a thorough understanding of the fundamentals and complexities of AC armature winding.

**Basic Principle of AC Armature Winding:** The creation of a spinning magnetic field and aiding the transformation of electrical energy into mechanical energy in an electric motor are the fundamental tenets of AC armature windings. Let's delve deeper into these guidelines:

**a. Magnetic Field Generation:** The main objective of the armature winding is to generate a magnetic field that interacts with the magnetic field of the stator to produce rotational motion. By running an alternating current through the winding, this is accomplished. Each coil's magnetic field is produced by the current flow, and when these fields combine, they produce a spinning magnetic field.

**b. Coils and Poles:** The winding of the armature is made up of several coils that are twisted around the armature core. The necessary qualities and the individual motor design determine the number of coils. To achieve an even distribution of the magnetic field, the coils are positioned in slots on the core. The quantity of coils needed for the armature winding depends on the number of magnetic poles on the stator.

**c. Winding Types:** Lap winding and wave winding are the two most common forms of AC armature windings. Lap winding is frequently employed in high current-demanding applications like traction motors. It entails creating a parallel circuit by connecting the beginning of each coil to its end. On the other hand, wave winding is appropriate for high-voltage, low-current applications like generators. In a series circuit, it joins the start of one coil to the end of the following coil.

**d. Commutator or Slip Rings:** The ends of the armature winding coil, sometimes referred to as the leads, are linked to a commutator or slip rings. The motor design determines which option is best between the two. DC motors and some varieties of AC motors frequently employ commutators. It is made up of insulated copper segments that are joined to the armature shaft. Current can flow to the winding when the brushes make contact with the commutator segments. Other AC motors, however, employ slip rings, which enable the electrical connection without the necessity for commutation.

**e. Wire Gauge and Insulation:** Because of its superior electrical qualities, copper wire with a high conductivity is frequently employed in armature windings. The wire's size or gauge is determined by the voltage, current, and power rating requirements for the motor design. A layer

of enamel or a similar coating is also applied to the wire to increase electrical insulation between neighbouring coils and the core and avoid short circuits[4]–[6].

**f. Slot Insulation:** To electrically separate the coils from the core and from each other, insulation materials are put into the slots on the armature core. This insulation guards against electrical short circuits and guarantees that the winding is operating correctly.

Engineers may design and build AC armature windings that produce the appropriate rotating magnetic field, enabling efficient and dependable running of electric motors, by comprehending and putting these fundamental concepts into practice. The requirements and intended use of the motor determine the particular design decisions, such as the winding type, wire gauge, insulation materials, and connecting technique.

## DISCUSSION

**Types of AC Armature Winding:**Lap winding and wave winding are the two primary forms of AC armature windings. Let's investigate each kind in further depth:

**1.Lap Winding:** Traction motors and other high-current applications frequently employ lap winding. It is distinguished by creating a parallel circuit by connecting the beginning of each coil to its end. Lap winding's essential characteristics include:

- a. **Parallel Circuit:** The coils are connected by lap winding in a parallel circuit arrangement, in which each coil is connected to every other coil in turn.
- b. **Multiple Parallel routes:** The number of parallel routes created by lap winding is equal to the number of poles on the motor's stator. A portion of the overall armature current travels along each parallel line.
- c. **Greater Current Capacity:** Lap winding efficiently manages large currents because it creates parallel channels. This qualifies it for uses that call for high power output.
- d. **Robustness:** Lap winding has superior fault tolerance and robustness. The motor can still run by avoiding the malfunctioning region through other parallel routes if one coil or segment of the winding breaks.

**2. Wave Winding:** Wave winding is frequently used in generators and other devices that need high voltage and little current. It is distinguished by connecting the beginning of one coil to the end of the following coil in a series circuit. The main aspects of wave winding are as follows:

- a. **Series Circuit:** A series circuit is one in which the beginning of one coil is connected to the end of the next coil. Wave winding is used to connect the coils in this type of circuit.
- b. **Single Series Path:** In contrast to lap winding, wave winding only uses one series path to wind the armature. This is the only channel via which the full armature current passes.
- c. **Wave winding's capacity to manage high voltage:** Wave winding is made to effectively handle high voltage levels. Applications requiring high voltage output can use it.
- d. **Lower Current Capacity:** Wave winding's series arrangement results in a decreased current carrying capability when compared to lap winding. It is frequently employed in situations when a high current is not necessary.

Lap winding or wave winding is selected based on the particular motor design specifications, such as power rating, voltage, and current. For high-current applications, lap winding is favored, whereas wave winding is appropriate for high-voltage ones. Based on the planned use of the AC motor, engineers carefully choose the right winding type to achieve maximum performance and efficiency.

**Design Consideration of AC Armature Winding:** To provide optimum performance, efficiency, and dependability, various factors must be taken into account while constructing AC armature windings for electric motors. The following are some crucial design factors:

- a. **Voltage and Current Requirements:** The design specifications for the armature winding are determined by the voltage and current ratings of the motor. It is important to choose the wire gauge and insulation thickness to withstand the anticipated current and voltage levels without overheating or voltage breakdown.
- b. **Magnetic Field Distribution:** An even and balanced magnetic field distribution should be produced by the armature winding. To guarantee a uniform distribution of magnetic flux and reduce negative consequences like magnetic imbalance and cogging, this necessitates precise coil placement in the armature core's slots.
- c. **Winding Type Selection:** The selection of the winding type relies on the particular needs of the motor and can be made between lap winding and wave winding. While wave winding is favored for high-voltage applications, lap winding is appropriate for high-current applications. The number of parallel or series routes, connecting mechanism, and winding pattern are all impacted by the winding type.
- d. **Slot Configuration:** When designing the armature winding, consideration must be given to the slot shape and size. Coils should be properly accommodated in the slots to provide good insulation and for effective winding arrangement. The density of the coil packing, cooling, and simplicity of manufacturing are all impacted by the size and form of the slots.
- e. **Coil Geometry and Turns:** Each coil's configuration within the armature winding must be carefully considered. The magnetic flux that is produced by the winding is determined by the number of turns in each coil. While maintaining sufficient insulation and limiting losses, the coils' size and form should be tailored to fit into the slot area that is now open.
- f. **Materials for Insulation:** Insulation is essential for ensuring reliable operation of the armature winding and preventing short circuits. To survive the electrical, thermal, and mechanical loads experienced during motor operation, it is critical to use the right insulating materials, such as enamels, tapes, or varnishes.
- g. **Commutator or Slip Rings:** Whether to use slip rings or a commutator depends on the application and design of the motor. Commutator or slip ring design and construction should take into account things like electrical contact, brush wear, voltage drop, and maintenance needs.
- h. **Thermal considerations:** To avoid an excessive temperature rise, the armature winding design should take heat dissipation into mind. To keep the winding's temperature within acceptable ranges and guarantee effective performance, appropriate cooling systems, such as forced air or liquid cooling, should be included.

**Manufacturing Restrictions:** When designing the armature winding, manufacturing restrictions should be taken into account. To make production operations more effective and efficient, factors including coil termination, ease of winding insertion, and connection to external components should be taken into consideration[7]–[9]. Engineers may create AC armature windings that perfectly operate, are highly efficient, and are dependable by taking into account these design aspects.

**Optimization Techniques of AC Armature Winding:** To improve the effectiveness, performance, and general quality of electric motors, AC armature windings must be optimized. Here are some typical methods for AC armature winding optimization:

- a. **Magnetic Field Analysis:** Analyze the distribution of the magnetic field inside the motor using electromagnetic modeling software or analytical methods. To create a consistent and effective magnetic field, the placement and arrangement of the armature windings are optimized with the aid of this study.
- b. **Winding Layout Optimization:** To increase packing density and reduce magnetic imbalance, optimize the winding layout by placing coils in the armature slots. This may entail methods like fractional slot winding, which more uniformly distributes the coils while lowering harmonics and boosting efficiency.
- c. **Wire Selection:** Consider characteristics like electrical resistance, thermal conductivity, and mechanical strength when choosing the right wire gauge and material. The armature winding's overall efficiency is improved and resistive losses are reduced thanks to wire selection optimization.
- d. **Multi-Objective Optimization:** Take into account a variety of performance goals, including decreasing copper losses, cutting down on cogging torque, and increasing torque output. The best trade-offs between various objectives can be discovered using multi-objective optimization approaches like genetic algorithms or Pareto optimization.
- e. **Loss Reduction:** Reduce stray, copper, and iron losses as well as other losses in the armature winding to a minimum. This may be accomplished by employing proper insulating materials, careful design and material selection, lowering resistance, and optimizing magnetic pathways.
- f. **Thermal Analysis:** Conduct thermal analysis to assess the armature winding's temperature distribution and pinpoint any possible hotspots. This study aids in the optimization of cooling mechanisms, such as better ventilation or the use of more effective cooling techniques, to raise the winding's thermal performance and dependability.
- g. **Manufacturing Optimization:** During the design phase, take into account manufacturing restrictions and optimization approaches. For instance, upgrading tools, automation, and the winding process may speed up production and cut costs while enhancing uniformity and quality.
- h. **Advanced Winding Methods:** Examine advanced winding methods including dispersed, concentrated, or hybrid windings. For particular motor performance needs, these methods optimize the winding configuration, current routes, and magnetic field distribution.

- i. **Electrical Loss Reduction:** Reducing parasitic effects like the skin effect and proximity effect will help cut down on electrical losses. These effects can be reduced and the armature winding's effectiveness increased by using methods like transposition, interleaving, or using flat or rectangular conductors.
- j. **Experimental Validation and Iterative Design:** Perform prototype testing and validation to confirm the effectiveness of the improved winding design. This is known as experimental validation and iterative design. Utilize the results of the testing to iteratively improve the winding design.

Engineers can boost the performance, reliability, and efficiency of AC armature windings, which would improve the efficiency of electric motors and lower energy consumption.

**Single Layer Winding:**Electrical equipment such as transformers and electric motors employ single-layer windings, commonly referred to as single-wire windings or single-conductor windings. Each coil in a single-layer winding has a single layer of conductor turns coiled on it. The turns of a single-layer winding are coiled next to one another without interleaving or layering. This describes a continuous and contiguous layer of conductors where each turn is in direct contact with the adjacent turns. Depending on the particular application and design specifications, the winding may be either concentric or dispersed. Single-layer windings' key benefits are their simplicity and ease of production. Compared to multi-layer windings, they use fewer conductors, which lowers the cost and simplifies the winding process. Due to the lack of insulating layers in between turns, single-layer windings also offer reduced resistance and better thermal properties. Single-layer windings do have certain restrictions, though. They frequently result in longer end-winding lengths, which may result in a rise in leakage inductance and losses. By using proper design and optimization approaches, this may be reduced. In applications where simplicity, cost-effectiveness, and convenience of manufacturing take precedence over the performance benefits provided by multi-layer windings, single-layer windings are frequently utilized. They are frequently found in small- to medium-sized motors, transformers, and other electrical equipment where weight and space restrictions are not as important.

**Concentric Winding:**Concentric winding is the name of a certain method used to build transformers or electrical coils. It entails spiraling or winding a central core or former around numerous layers of insulated wire in a circular manner. In concentric winding, the turns of wire in each layer are placed side by side and each layer of wire is wound directly on top of the previous layer. Depending on the particular application and design needs, the number of layers may change. The primary benefit of concentric winding is that each layer of wire is tightly packed together, making efficient use of available space possible. Consequently, a small coil or transformer design is produced. Concentric winding also contributes to reducing electromagnetic interference between the windings and offers superior mechanical stability. Transformers, inductors, solenoids, and electric motors are just a few examples of the different electrical appliances and equipment that frequently employ concentric winding. Based on the electrical and magnetic requirements of the application, the specific winding process and parameters, such as wire gauge, number of turns, and insulation materials, are chosen[10].

**Double Layer Winding:**Lap winding, another name for double-layer winding, is a process used in the manufacture of electrical equipment including DC motors and generators. On a revolving armature or stator core, two layers of coils are wound side by side. When winding two layers of



coils, the first layer of coils is wound first, and the second layer is then added on top. Up until all of the coils are in place, the winding procedure is repeated. Each layer's coils are connected in series, and the two layers are connected in parallel. The fundamental benefit of double-layer winding is that it enables more turns to fit into a given area, increasing voltage or output. By increasing the surface area between the layers, this winding approach also improves coil cooling. Additionally, it aids in lowering the winding's overall resistance, improving efficiency. Double-layer winding does have some restrictions, though. To maintain appropriate coil connections and avoid short circuits, meticulous attention to the winding sequence is necessary. Comparing the winding process to various winding methods can potentially reveal additional complexity and time requirements. In general, double-layer winding is a frequently utilized method in electrical machines where high power output and efficiency are necessary, such as in industrial applications and electric vehicles.

## CONCLUSION

To sum up, AC armature windings are essential components of AC machines that allow electrical energy to be converted to mechanical energy and vice versa. The quality and effectiveness of these machines are substantially impacted by the armature windings' structure and design. Voltage, current, speed, and power needs all influence the choice of winding arrangement, such as lap winding or wave winding. To achieve dependable and sturdy armature windings, design factors such as conductor material, insulation, and cooling techniques are crucial. To improve performance, decrease losses, and boost overall efficiency of AC equipment, optimization techniques can be used. Engineers and researchers can progress the creation of more effective and dependable AC machines for a variety of applications by comprehending the fundamentals and properties of AC armature windings.

## REFERENCES:

- [1] S. You, S. S. Kalsi, M. D. Ainslie, R. A. Badcock, N. J. Long, and Z. Jiang, "Simulation of AC Loss in the Armature Windings of a 100 kW All-HTS Motor with Various (RE)BCO Conductor Considerations," *IEEE Access*, 2021, doi: 10.1109/ACCESS.2021.3114398.
- [2] X. Xu, Z. Huang, X. Huang, F. Dong, and Z. Hong, "AC Loss Estimation on HTS Armature Windings for a 30-kW Marine Generator Prototype," *J. Supercond. Nov. Magn.*, 2021, doi: 10.1007/s10948-020-05719-4.
- [3] S. Fukui, S. Tsukamoto, K. Nohara, J. Ogawa, T. Sato, and T. Nakamura, "Study on AC Loss Reduction in HTS Coil for Armature Winding of AC Rotating Machines," *IEEE Trans. Appl. Supercond.*, 2016, doi: 10.1109/TASC.2016.2535208.
- [4] S. Kalsi, K. Hamilton, R. G. Buckley, and R. A. Badcock, "Superconducting AC homopolar machines for high-speed applications," *Energies*, 2019, doi: 10.3390/en12010086.
- [5] a. M. Morega and J. C. Ordonez, "Thermal Stability of an HTS AC Armature Winding," *Proc. COMSOL Multiphysics User's Conf.*, 2005.
- [6] H. Shin and J. Chang, "Comparison of Radial Force at Modulating Pieces in Coaxial Magnetic Gear and Magnetic Geared Machine," *IEEE Trans. Magn.*, 2018, doi:

- 10.1109/TMAG.2017.2768552.
- [7] M. Zhang *et al.*, “AC loss estimation of HTS armature windings for electric machines,” *IEEE Trans. Appl. Supercond.*, 2013, doi: 10.1109/TASC.2013.2239341.
- [8] X. Song, N. Mijatovic, B. B. Jensen, and J. Holbøll, “Design Study of Fully Superconducting Wind Turbine Generators,” *IEEE Trans. Appl. Supercond.*, 2015, doi: 10.1109/TASC.2015.2396682.
- [9] X. Deng, Z. Jia, and X. Zhao, “Design and analysis of a novel hybrid excitation flux reversal machine,” *Appl. Comput. Electromagn. Soc. J.*, 2021, doi: 10.47037/2020.ACES.J.360215.
- [10] T. W. Ching, Y. Shi, W. Li, and L. Jian, “Design and Analysis of a Magnetless Linear Variable Reluctance Motor with Modular Mover Units for Electric Propulsion,” *IEEE Trans. Appl. Supercond.*, 2020, doi: 10.1109/TASC.2020.2975767.

## DC MACHINES: THEORY, CONSTRUCTION, AND OPERATION

**Mr. Vesapogu Joshi\***

\*Associate Professor,  
Department of Electrical And Electronics Engineering,  
Presidency University, Bangalore, INDIA  
Email Id-joshimanohar@presidencyuniversity.in

---

### ABSTRACT:

*Direct current (DC) machines are electrical equipment that change DC electrical energy into mechanical energy or the other way around. Since their conception, they have been a fundamental component of electrical engineering and have a wide range of uses in several systems and sectors. Direct current (DC) machines are electrical equipment that transform DC electrical energy into mechanical energy or the opposite. They are extensively employed in many different applications, including electric vehicles, business equipment, and renewable energy sources. An overview of DC machines is given in this chapter, along with information on their types, uses, and benefits.*

**KEYWORDS:** Armature Winding, Commutator, Dc Machines, Dc Generators, Dc Motor, Electrical Energy, Mechanical Energy.

---

### INTRODUCTION

Direct current machines, often known as DC machines, are electro-mechanical systems that use direct current to change electrical energy into mechanical energy or the other way around. They are extensively utilized in many different applications, such as those involving industrial machines, transportation networks, and renewable energy sources. An overview of DC machines' design, operation, kinds, and applications is given in this article. The stator and the rotor are the two fundamental components of DC machines. The field winding, which generates a magnetic field when direct current is fed through it, is housed in a stationary frame that makes up the stator. On the other side, the rotor is the machine's revolving component that transports the armature winding. The load current travels through the armature winding, which is coupled to the external circuit. A DC machine's operation is based on electromagnetic induction's Faraday's law. A magnetic field is produced in the space between the stator and rotor when current is run via the field winding.

When the rotor rotates, this magnetic field causes an electromotive force (EMF) to be induced in the armature winding. The rotor rotates as a result of the mechanical force created by the magnetic field's interaction with the armature winding current. DC motors and DC generators are the two primary types of DC machines. DC generators transform mechanical energy into electrical energy, and DC motors transform electrical energy into mechanical energy. Robotics, electric vehicles, and industrial machinery are just a few of the many uses for DC motors. They are appropriate for applications that call for high-performance control because they offer precise speed and torque control. Depending on how they are built, DC motors can be further categorized as series-wound, shunt-wound, or compound-wound motors[1]–[3].The field

winding and armature winding of a DC motor that is series wound are linked together. High beginning torque is offered by this design, although speed control is only moderate. Electric forklifts and locomotives are two common examples of applications that use series-wound motors and demand significant starting torque.

The field winding and armature winding of shunt-wound DC motors are linked in parallel. With this configuration, the field current can be independently controlled, improving speed control. Conveyor belts and lathes are two common applications for shunt-wound motors that demand consistent speed. DC motors with compound wounds combine the advantages of both series and shunt wound motors. Both a series field winding and a shunt field winding are present in them, resulting in a motor with a strong starting torque and accurate speed control. Hoists and elevators are two common applications for compound-wound motors that need strong torque and variable speed. Direct current power is generated by DC generators, commonly referred to as dynamos, by transforming mechanical energy into electrical energy. They are frequently utilized in applications like battery charging systems and portable power sources where a steady and consistent source of DC power is needed. Depending on how they are excited, DC generators can be further divided into many categories, including independently excited, self-excited, and permanent magnet generators. Generators that are separately stimulated have a different source of current for the field winding. They are utilized in applications that demand precision power generation, such as laboratory equipment and research facilities, and offer good voltage control.

Self-excited generators supply the field winding with current using the output current from the armature winding. Series, shunt, and compound generators are the three categories that can be further divided into. With the field winding and armature winding coupled in series, series generators can adjust voltage to a limited extent while offering high current. Shunt generators offer superior voltage control since the field winding and armature winding are connected in parallel. Compound generators provide a balance between current and voltage control by combining the qualities of both series and shunt generators. Instead of using field windings to create the magnetic field, permanent magnet generators use permanent magnets. They are suitable for portable and small-scale applications because they are portable, lightweight, and low maintenance. DC machines are adaptable electro-mechanical systems that are essential in a variety of sectors. DC machines provide dependable and effective solutions for generating electricity, operating industrial gear, and powering electric vehicles. DC machines, which come in a variety of kinds and combinations, offer versatility in addressing particular application requirements, making them an essential part of contemporary technology.

### **Historical Background of DC Machines**

DC machines were created in the early 19th century, when researchers and inventors started experimenting with electromagnetism. Michael Faraday was one of the important figures in this area, and his pioneering research on electromagnetic induction served as the impetus for the creation of DC machines. By rotating a copper disc between the poles of a horseshoe magnet in 1821, Faraday showed how electromagnetic induction works. This experiment demonstrated that a magnetic field change might cause an electric current to flow through a conductor. The discovery made by Faraday paved the path for the creation of motors and generators. Joseph Henry, another significant person in the development of DC machines, was carrying out comparable experiments at the same time. Henry successfully proved electromagnetic induction

in 1831 by employing a wire coil to create a current in a nearby coil. Transformers and other electrical devices were developed on the foundation of this idea. Michael Faraday created the homopolar motor, the first usable DC machine, in 1821. A disc or cylinder that rotated between a magnet's poles made up the homopolar motor. With the help of electromagnetic induction, this motor showed how electrical energy may be transformed into mechanical energy.

The first DC electric motor was created in the 1830s by American blacksmith and inventor Thomas Davenport. The commutator in Davenport's motor allowed the motor to rotate continuously by switching the direction of the current flowing through the armature coil. His creation paved the way for the creation of useful DC motors. DC machine development accelerated in the late 19th century thanks to the work of innovators like Zénobe Gramme and Thomas Edison. The Gramme machine was created in 1871 by Belgian electrical engineer Zénobe Gramme. It represented a considerable advancement over earlier models. A ring armature and a commutator were built into the Gramme machine to increase efficiency and performance.

The prolific inventor Thomas Edison made substantial contributions to the creation of DC devices. Edison concentrated on enhancing the functionality and design of DC motors and generators in the late 1870s. In addition to creating the first commercially successful DC power distribution system, he brought innovations like the carbon brush, a gadget that replaced the conventional mercury or copper contacts in the commutator. The development of the first centralized electric power plants, made possible by Edison's work on DC machines, allowed for the widespread use of electric lighting and the electrification of cities. The early years of electric power distribution were dominated by the DC method invented by Edison. The supremacy of DC machines was, however, challenged in the late 19th century by the invention of AC (alternating current) technology by innovators like Nikola Tesla and George Westinghouse. Long-distance power transmission and simple voltage conversion with transformers were two benefits of using AC systems.

The struggle between Edison's DC system and Westinghouse's AC system, known as the War of Currents, eventually resulted in the universal acceptance of AC power for the distribution of electric power. Due to their technical benefits, AC devices like induction motors and generators have become the standard option. Despite this, DC machines were nonetheless used in a variety of industries, such as electric traction systems, where they provided steady and manageable power for electric trams and locomotives. In addition, the usage of DC machines in applications like variable speed motors and renewable energy systems was revived by the invention of solid-state power electronics. DC machines have seen a renaissance recently thanks to improvements in power electronics and control systems, especially in renewable energy applications like wind turbines and solar power systems. They are important parts of these new technologies because of their capacity to deliver effective power conversion and control. Research into the fundamentals of electromagnetic by scientists and innovators had a key role in the historical development of DC machines. DC machines have played a major role in the advancement of electrical engineering and have had a significant influence on the modern world, starting with the early experiments of Faraday and Henry and continuing with the innovations of Davenport, Gramme, and Edison[4]–[6].



## DISCUSSION

**Construction of DC Machine:** DC machines are built with a number of crucial parts that make them functional. The stator, rotor, armature winding, field winding, commutator, brushes, and frame are some of these parts.

- a. **Stator:** The stator, which is the DC machine's stationary component, is often constructed of a magnetic substance such laminated iron cores. It contains the field winding, which when a current flows through it creates a magnetic field. The magnetic flux created by the field winding travels along the stator.
- b. **Rotor:** The DC machine's revolving component, connected to the mechanical load, is known as the rotor. It can be built in a variety of shapes, including a cylinder or a disc. The armature winding is carried by the rotor, which rotates within the stator's magnetic field.
- c. **Armature Winding:** On the rotor, there is a set of insulated conductors that make up the armature winding. In order to generate mechanical or electromotive force (EMF), it is responsible for conveying the load current and reacting with the magnetic field. The external circuit is connected to the armature winding, enabling current flow.
- d. **Field Winding:** On the stator are a number of coils that make up the field winding. To create either a series, shunt, or compound field winding configuration, it is linked in series or parallel. When a current flows through the field winding, a magnetic field is created, generating the necessary flux for interaction with the armature winding.
- e. **Commutator:** Situated on the rotor, the commutator is a cylindrical component. It is made up of copper segments that are attached to the ends of the armature winding and are isolated from one another. As the rotor turns, the commutator acts as a mechanical rectifier, changing the flow of current in the armature winding. This reversal makes sure that the machine's generated torque is still in a single direction.
- f. **Brushes:** The brushes are sliding contacts between the commutator segments and conductor carbon or graphite blocks. They enable the exchange of electrical energy between the armature winding and the external circuit by supplying current to and removing current from the commutator. The brushes are normally spring-loaded and fixed on brush holders to ensure constant contact with the commutator.
- g. **Frame:** The frame houses the DC machine's internal parts and offers structural support. Typically, it is constructed from a stiff material like cast iron or steel. The frame also serves as a casing for protection, keeping outside elements out of the machine.

The integration of the stator, rotor, armature winding, field winding, commutator, brushes, and frame is necessary for the design of DC machines. These parts cooperate to enable the controlled and effective conversion of electrical energy into mechanical energy or vice versa.

**Armature Winding and Commutator:** A dc machine is a heteropolar structure made up of a spinning armature and fixed poles. Each coil experiences an alternate emf with the identical B-wave waveform. For a 4-pole machine, as shown in Figure 1, the emfs generated as the armature spins are unidirectional and alternate between the coil-sides under each pole. The emf pattern and the coil side current pattern are identical. The only difference is that while the current in the coil-side reverses, the current exchanged with the external circuit must be unidirectional and the

voltage exchanged with the external circuit must be constant and of the same polarity (d.c.). The coil-side emf also decreases as it moves towards the outer side of the poles. This is the rectification process that the mechanical rectifier, which consists of a commutator-brush assembly, performs.

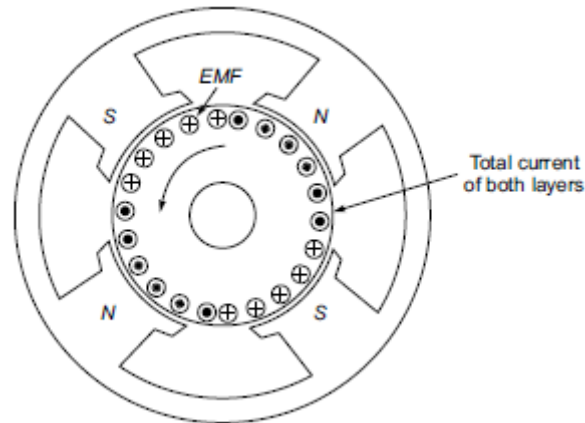

**Figure 1: Representing the 4-Pole DC Machine [EEE Guide].**

**Types of DC Machines:** The two primary categories of DC machines are DC motors and DC generators. Let's investigate each kind in greater depth:

**1.DC Motors:** DC motors are utilized in many applications that call for controlled motion and transform electrical energy into mechanical energy. They are appropriate for a wide range of industrial, commercial, and residential applications because they provide precise speed and torque control. Based on their design and the way the field winding is connected, DC motors can be further divided into different groups. Among the most common types of DC motors are:

- a. **Series-Wound DC Motor:** The field winding and armature winding of series-wound DC motors are coupled together. With its strong beginning torque, this arrangement is appropriate for uses like electric traction and hoists. Series motors can control speed to a certain extent, though.
- b. **Shunt-Wound DC Motor:** Shunt-wound DC motors have parallel connections between the armature and field windings. This arrangement offers improved speed control and a more stable speed characteristic by enabling independent control of the field current. Shunt-wound motors are frequently employed in machinery and conveyors that demand a consistent speed.
- c. **Compound-Wound DC Motor:** DC motors that are compound-wound have the advantages of both series and shunt-wound motors. They have a shunt field winding as well as a series field winding. Motors with compound windings strike a balance between strong starting torque and accurate speed regulation. They are frequently utilized in equipment including rolling mills, elevators, and electric cars.

**2.DC Generators:** Dynamos, sometimes referred to as DC generators, transform mechanical energy into electrical energy. They provide direct current power for use in a variety of applications. Depending on how the field is excited, DC generators can be divided into different groups. Among the most common types of DC generators are:

- a. **Separately Excited DC Generator:** DC generators that are separately stimulated have a different source of current for the field winding. Direct current is provided to the field winding from an external source, allowing for exact control of the voltage generated. Applications requiring precise and reliable voltage control use separately excited generators.
- b. **Self-Excited DC Generator:** Self-excited generators employ the armature winding's output current to supply the field winding with current. Three subtypes can be used to further categorize them.
- c. **Series DC Generator:** In series generators, the armature winding and field winding are wired together in series. Series generators have a limited ability to adjust voltage while producing high currents. They are frequently employed in processes like arc welding and battery charging.
- d. **Shunt DC Generator:** In shunt generators, the armature winding and field winding are connected in parallel. When compared to series generators, they offer superior voltage control. Applications that call for a consistent voltage output, including battery charging systems and small power plants, frequently use shunt generators.
- e. **DC compound generators:** Shunt and series shunt generator characteristics are combined in compound generators. They have a shunt field winding as well as a series field winding. Compound generators are appropriate for a variety of applications because they provide a balance between current and voltage control.

These are the primary categories of DC machines, which also include DC motors and DC generators and are essential in a wide range of fields and applications.

**Applications of DC Machines:** Due to their distinct qualities and capacities, DC machines are used in a wide range of industries and sectors. The following are some typical uses for DC machines:

- a. **Industrial Machinery:** DC motors are frequently employed in industrial machinery to power a variety of mechanical systems. They are used in mixers, pumps, compressors, machine tools, conveyor belts, and other machinery that needs precise torque and speed control. DC motors deliver dependable and effective power for these commercial uses [7]–[9].
- b. **Electric Vehicles:** DC motors are frequently utilized for propulsion in electric cars (EVs). They offer the torque and speed control necessary for the effective and smooth functioning of EVs, such as electric vehicles for transportation such as buses, scooters, and bicycles. DC motors aid in the creation of environmentally friendly transportation options.
- c. **Renewable Energy Systems:** Systems for producing renewable energy, such wind turbines and solar power systems, heavily rely on DC machinery. Wind turbines employ DC generators to transform mechanical energy from wind into electrical energy. Similar to this, DC generators are utilized in solar power systems to turn the sunlight collected by solar panels into usable electricity.
- d. **Battery Charging Systems:** To transform mechanical energy into electrical energy for charging batteries, battery charging systems use DC generators. They are frequently used in

products like portable power supplies, uninterruptible power supply (UPS) systems, and battery chargers for cars.

- e. **Robotics:** Due to their fine control and small size, DC motors are widely employed in robotic systems. They allow for precise placement and movement of robotic arms, grippers, and other parts. For a variety of robotics applications in industry, medicine, and research, DC motors provide the necessary power and control.
- f. **Traction Systems:** Electric trains, trams, and other electric vehicles use traction systems, which employ DC motors, particularly series-wound DC motors. They are appropriate for applications requiring rapid acceleration and large initial loads because they have a strong starting torque.
- g. **Home Appliances:** DC motors are used in a variety of household appliances, such as fans, refrigerators, washing machines, and vacuum cleaners. They contribute to the performance and energy efficiency of these appliances by ensuring dependable and efficient functioning.
- h. **Laboratory Equipment:** DC machines are used in centrifuges, stirrers, and precise motion control systems, among other laboratory apparatus. They are perfect for conducting tests and research in scientific facilities because to their exact speed and torque control.

These are but a few of the numerous uses for which DC machines are put to use. They are vital in a wide range of industries and sectors where electrical energy needs to be turned into mechanical energy or vice versa due to their adaptability, controllability, and efficiency.

**Advantages and Disadvantages of DC Machines:**When choosing DC machines for particular applications, it's crucial to take into account both their benefits and drawbacks. Let's examine the benefits and drawbacks of DC machines.

#### **Featured Benefits of DC Machines**

- a. **Accurate Speed and Torque Control:** DC machines offer superb speed and torque control, enabling accurate and effective operation in a variety of applications. They are useful for applications that demand precise control of rotational speed because they can maintain constant speed under a variety of load circumstances.
- b. **High Starting Torque:** DC motors, particularly series-wound DC motors, have a high starting torque, which makes them ideal for applications where a high initial torque is needed to start heavy loads and overcome inertia.
- c. **Simple and Robust Construction:** DC machines have a very simple and robust structure, which contributes to their durability and operational dependability. They are less complicated than some other kinds of machines, making maintenance simpler and reducing the likelihood of failure.
- d. **Wide Speed Range:** DC machines can work at both high and low speeds over a large speed range. They are excellent for applications requiring varied speeds, such as machine tools and traction systems, because to their flexibility.
- e. **Efficiency:** DC machines can operate at or close to their rated loads to attain great levels of efficiency. They are capable of efficiently converting electrical energy into mechanical energy with only little losses.

### Negative Aspects of DC Machines

- a. **Commutation and Brush Wear:** DC machines transfer electrical energy between the armature winding and external circuit using mechanical brushes and commutators. Over time, the brushes deteriorate and may need regular maintenance and replacement. Additionally, sparking and electrical noise from the commutation process may interfere with delicate electronic equipment.
- b. **Limited Speed Control Range:** While DC machines provide superior speed control, their speed control range is constrained when compared to some other machine types. Due to centrifugal forces acting on the rotating components, DC machines may experience restrictions while operating at very high speeds.
- c. **Complex Control Systems:** Pulse-width modulation (PWM) controllers, feedback mechanisms, and other complex control systems are frequently needed to achieve accurate control over speed and torque in DC machines. The complexity of control systems can raise the cost of the entire system and necessitate more technical know-how for implementation.
- d. **Cooling Requirements:** DC machines can produce heat while operating, particularly under heavy loads. To maintain ideal operating temperatures and avoid overheating, adequate cooling devices, such as fans or liquid cooling systems, may be required [10].
- e. **Limited Availability of DC Power:** Despite the adaptability of DC machines, some applications may have a limited supply of DC power sources. Rectifiers or converters are needed to convert AC power into DC power for DC devices because the majority of power networks and electrical systems use AC power.

When deciding between DC machines and other types of machines, it's crucial to take these advantages and disadvantages into account in the context of the needs for a particular application.

### CONCLUSION

Due to their capacity to transform electrical energy into mechanical energy and vice versa, DC machines are essential in a wide range of industries and applications. They provide a lot of benefits, such as great efficiency, controllability, and dependability. The numerous types of DC machines, including DC motors and generators, meet a range of requirements in a variety of industries. The development of electric vehicles, industrial automation, and renewable energy systems are all made possible by the continued evolution and development of DC machines. Future electrical systems must be efficient and sustainable, which means that understanding DC machines and furthering their development is essential.

### REFERENCES:

- [1] C. L. V. R. S. V. Prasad, G. V. S. S. Sharma, and P. N. L. Pavani, "Capability resurrection of DC sputtering machine: A case study," *Int. J. Surf. Eng. Interdiscip. Mater. Sci.*, 2021, doi: 10.4018/IJSEIMS.2021010104.
- [2] X. Hu, L. P. Tatum, S. F. Almeida, T. K. Esatu, and T. J. K. Liu, "Study of DC-Driven MEM Relay Oscillators for Implementation of Ising Machines," in *Technical Digest - International Electron Devices Meeting, IEDM*, 2021. doi:



- 10.1109/IEDM19574.2021.9720617.
- [3] S. Eriksson, "Permanent magnet synchronous machines," *Energies*, 2019, doi: 10.3390/en12142830.
- [4] S. Bazhar, J. Fontchastagner, N. Takorabet, and N. Labbe, "Hybrid Analytical Model Coupling Laplace's Equation and Reluctance Network for Electrical Machines," *IEEE Trans. Magn.*, 2017, doi: 10.1109/TMAG.2017.2654966.
- [5] M. Tavruri *et al.*, "Maximum power point tracking of PV system based on machine learning," *Energies*, 2020, doi: 10.3390/en13030692.
- [6] M. J. Lanovaz, A. R. Giannakakos, and O. Destras, "Machine Learning to Analyze Single-Case Data: A Proof of Concept," *Perspect. Behav. Sci.*, 2020, doi: 10.1007/s40614-020-00244-0.
- [7] Y. A. Alhaj, J. Xiang, D. Zhao, M. A. A. Al-Qaness, M. Abd Elaziz, and A. Dahou, "A Study of the Effects of Stemming Strategies on Arabic Document Classification," *IEEE Access*, 2019, doi: 10.1109/ACCESS.2019.2903331.
- [8] L. Ortiz, L. B. Gutiérrez, J. W. González, and A. Águila, "A novel strategy for dynamic identification in AC/DC microgrids based on ARX and Petri Nets," *Heliyon*, 2020, doi: 10.1016/j.heliyon.2020.e03559.
- [9] T. Zhang *et al.*, "Application of Radiomics Analysis Based on CT Combined With Machine Learning in Diagnostic of Pancreatic Neuroendocrine Tumors Patient's Pathological Grades," *Front. Oncol.*, 2021, doi: 10.3389/fonc.2020.521831.
- [10] T. H. Liao and C. J. Keng, "Online shopping delivery delay: Finding a psychological recovery strategy by online consumer experiences," *Comput. Human Behav.*, 2013, doi: 10.1016/j.chb.2013.03.004.

## OVERVIEW OF DC GENERATORS AND ITS FUNCTIONS

**Mrs. Ramya\***

\*Assistant Professor,  
Department of Electrical And Electronics Engineering,  
Presidency University, Bangalore, INDIA  
Email Id-ramyak@presidencyuniversity.in

---

### ABSTRACT:

*Direct current generators (DC generators), commonly referred to as dynamos or dynamos, are electromechanical devices that transform mechanical energy into electrical energy. For more than a century, they have been essential in numerous industries and applications. A major advancement in electrical engineering was the creation of DC generators, which made it possible to produce and use direct current to power a variety of appliances and systems. DC generators use the electromagnetic induction principle to transform mechanical energy into electrical energy. They are essential in a variety of operations, including manufacturing, electric vehicle production, and power generation. In this chapter, the working theory, components, and applications of DC generators are briefly discussed.*

**KEYWORDS:** *Armature Winding, Dc Generator, Excited Dc Generator, Parallel Dc Generator, Self-Excited Dc Generator.*

---

### INTRODUCTION

An electrical device that transforms mechanical energy into direct current (DC) electricity is referred to as a DC generator, sometimes known as a dynamo or a direct current generator. It functions according to the electromagnetic induction theory, which states that an electric current is produced when a conductor moves through a magnetic field. A stator, rotor, brushes, and commutator are the fundamental parts of a DC generator. The generator's stator, which is stationary, is made up of an electro- or permanently magnetized magnetic field. The revolving component of the generator is called the rotor, and it is commonly constructed from a coil of wire coiled around an iron core. According to Faraday's law of electromagnetic induction, an electromotive force (EMF) is produced when the rotor is rotated within a magnetic field because the magnetic lines of force cross the conductor. A potential difference caused by this EMF causes electrons to flow through the conductor, producing a current.

An alternating current (AC) waveform is produced as a result of the current's changing direction while the rotor rotates. Using a commutator, the generated AC is transformed into DC. A series of copper segments installed on the rotor shaft make up the commutator. Each segment is attached to the rotor coil at one end. Metal brushes in contact with the commutator segments ensure that the current flows in the same direction as the rotor rotates, essentially transforming alternating current into direct current. The brushes' DC output can be extracted and applied in a variety of ways. The DC generator's output voltage and current are affected by variables like rotational speed, magnetic field strength, and coil turn count. DC generators provide a number of benefits and uses. They are excellent for uses including battery charging, electroplating, and

electric traction systems because they can supply a consistent and reliable source of DC power. Additionally, they are utilized in little portable gadgets like hand-cranked radios and torches. Separately excited generators, shunt generators, series generators, and compound generators are some of the various types of DC generators[1]–[3].

Each variety has distinctive qualities and uses. For instance, a shunt generator produces a constant voltage by connecting a parallel field winding across the armature. In contrast, a series generator can produce a large starting torque because the field winding is linked in series with the armature. DC generators need maintenance and attention in order to operate properly. To guarantee optimum performance and longevity, the components should be inspected, cleaned, and lubricated on a regular basis. To prevent excessive wear and tear, it is also necessary to routinely inspect and replace the brushes and commutator. A DC generator is an electrical device that uses electromagnetic induction to transform mechanical energy into direct current electricity. The stator, rotor, brushes, and commutator are its primary parts. The generator creates an alternating current by rotating the rotor in a magnetic field; this alternating current is then transformed into direct current via a commutator. DC generators are used in many different industries and are renowned for their consistent and reliable power generation. In order to ensure their effective performance, proper maintenance is essential.

**Historical Background of DC Generator:**Early 19th-century scientists and innovators started experimenting with the concepts of electricity and magnetism, which led to the creation of the DC generator. Generators were made possible because to Michael Faraday's discovery of electromagnetic induction in 1831. The Pixii machine was created in 1832 by French instrument maker Hippolyte Pixii, marking the first substantial advancement. It was an early type of magneto-electric generator that generated alternating current using a spinning magnet and a coil of wire. Despite the fact that it was an AC generator, it helped to pave the way for later developments in generator technology. A number of innovators made significant contributions to the development of DC generators around the middle of the 19th century. One of the first useful DC generators was the dynamo, created in 1866 by German engineer Werner von Siemens.

Direct current was generated by the device, which was made up of a wire-wound rotor revolving within a stable magnetic field. American inventor Thomas Edison and his colleagues achieved important breakthroughs in DC generator technology in the late 19th century. Edison understood the potential of DC power for industrial and domestic uses. The Edison system, which he created, was the first DC power distribution system that was commercially feasible and employed DC generators to distribute electricity to diverse consumers. Self-excited shunt-wound generators served as the foundation for Edison's DC generators. These generators created direct current by regulating the field current using a shunt winding and using permanent magnets or electromagnets to produce the magnetic field. Early in the 20th century, DC generator development was still going strong. Generators' efficiency and design were improved by engineers and innovators, who also increased their dependability. Improved materials were introduced, such as laminated iron cores for the rotor, which helped decrease energy losses and boost overall effectiveness.

However, the widespread usage of AC power networks ultimately caused a fall in the large-scale use of DC generators. The use of transformers to efficiently change voltages during AC power transmission allowed electricity to be sent over vast distances with reduced energy loss. Despite

this, DC generators are still used in many different industries. In the early days of electric propulsion for trains and trams, while DC motors were the preferred option, they were widely used. For powering small-scale electrical equipment and charging batteries, DC generators were also essential. Recent years have seen a resurgence in interest in DC generators due to developments in power electronics and the rising demand for renewable energy sources. They work in tandem with renewable energy technologies like solar and wind power to transform the AC power produced into DC for direct use or storage. The DC generator's importance in the early development of electrical power networks is generally highlighted by the historical background of the device. DC generators continue to be utilized in certain applications and are still relevant in today's power production and conversion technologies, despite the fact that AC power has largely taken over large-scale applications.

**Working principle of DC Generator:** The fundamental idea of electromagnetic induction, which was discovered by Michael Faraday in the early 19th century, serves as the foundation for a DC generator's operation. According to this, a conductor's motion in relation to a magnetic field causes an electromotive force (EMF) or voltage to develop across the conductor. This idea is how DC generators transform mechanical energy into electrical energy. The stator, which is stationary, and the rotor, or armature, which rotates, are the two primary parts of a DC generator. Let's examine a DC generator's operation in greater detail:

1. **Magnetic Field Generation:** A DC generator's stator is where the field magnets that provide a constant magnetic field are housed. Permanent magnets or electromagnets can be used as the field magnets. In the case of electromagnets, the magnetic field is produced by feeding a direct current into the field windings.
2. **Armature and Commutator:** Within the magnetic field produced by the stator, the rotor, or armature, is a revolving component positioned on a shaft. The armature is made up of windings, which are normally constructed of copper conductors, and a laminated iron core designed to minimize eddy current losses. As the rotor rotates, the armature windings are positioned so that they intersect the magnetic field's lines. According to Faraday's law of electromagnetic induction, this relative motion creates an electromotive force, or voltage, across the armature windings. A commutator is utilized to guarantee a unidirectional flow of current. The armature windings are connected to a set of copper segments that are spaced apart and used as the commutator. The conductive elements known as brushes, which are frequently formed of carbon or graphite, make contact with the commutator segments [4]–[6].
3. **Voltage Generation:** The conductors in the armature windings cross the magnetic field lines as the armature rotates inside the magnetic field. This cutting motion creates a voltage in the armature windings in accordance with Faraday's law. The pace at which the armature conductors cut the magnetic field lines determines how much voltage is induced.

The Faraday's law equation can be used to calculate the intensity of the induced voltage:

$$EMF = N * B * A * \omega * \sin(\theta)$$

Where: EMF = Electromotive force or induced voltage

N = Number of turns in the armature winding

$B$  = Magnetic field strength

$A$  = Area of the armature coil

$\omega$  = Angular velocity of the armature

$\theta$  = Angle between the magnetic field lines and the armature conductor

4. **Commutation:** In order to transform the alternating voltage induced in the armature windings into direct current, the commutator is a key component. Different commutator segments make contact with the brushes as the armature rotates, paving the way for current flow. A section of the commutator connects to the external circuit when it comes into contact with the brushes, allowing current to flow out. The other section that had been in touch with the brushes is also simultaneously disengaged from the external circuit. Commutation, a switching process, ensures that the current in the external circuit flows in the same direction, producing a direct current output.
5. **Output and Load:** The brushes and commutator pass the direct current produced by the DC generator to the external circuit. The external circuit, sometimes referred to as the load, can include any number of appliances or machinery that make use of the generator's electrical output. The load uses the DC generator's electrical energy to carry out useful tasks. Depending on the exact application, this labor may involve driving lights, motors, electronics, or industrial operations. Electromagnetic induction serves as the foundation for a DC generator's operation. The conductors in the armature windings cross the magnetic field lines as the armature spins within the stator's magnetic field, producing a voltage. The commutator makes sure that the alternating voltage is converted into direct current, and the output DC power is then sent to the external circuit or load to be used.

## DISCUSSION

**Key Components of DC Generator:** A DC generator is made up of a number of essential parts that cooperate to transform mechanical energy into electrical energy. Let's investigate these elements in greater detail:

- a. **Stator:** The DC generator's stator is its stationary component. It houses the field magnets and acts as the main structural support. Depending on the generator type, the field magnets may be either permanent magnets or electromagnets. The magnetic field within which the armature revolves is stable and continuous thanks to the stator.
- b. **Rotor (Armature):** The rotating component of a DC generator is referred to as the rotor or armature. It is responsible for producing the electrical output and is positioned on a shaft. To minimize eddy current losses, the armature has a laminated iron core. The armature windings are looped around the core and connected to the commutator. Typically, they are constructed of copper wire.
- c. **Commutator:** An essential part of a DC generator is the commutator. It is made up of a number of installed on the armature shaft copper segments that are electrically isolated from one another. These segments are joined to the armature windings. The mechanical rectifier function of the commutator ensures that the generated alternating voltage is changed into direct current. It accomplishes this by maintaining a unidirectional flow of current by periodically reversing the connection of the armature windings to the external circuit.



- d. Brushes:** The brushes are typically constructed of carbon or graphite and are conductive materials. As the armature rotates, they come into touch with the commutator segments, allowing current to flow between the armature windings and the external circuit. The brushes are fixed to stationary holders and made to ensure appropriate contact with the commutator while offering a low-resistance electrical connection.
- e. Load:** The external circuit or devices connected to the DC generator's output terminals are referred to as the load. The load uses the electrical energy produced by the generator to carry out productive tasks. Depending on the application, other items, such as lighting, motors, electronic devices, or industrial machinery, may be included in the load.
- f. Field Excitation System:** The field excitation system is a supplementary component found in some DC generators. The current required to power the field magnets must be supplied via this system. It makes sure that the magnetic field intensity is constant and under control, which impacts the generator's performance and output voltage. For separately excited generators, the field excitation system can be a separate power source, whereas for self-excited generators, it can be a component of the generator itself.

In a DC generator, these vital parts collaborate to transform mechanical energy into electrical energy. The armature windings cross the field lines, the commutator turns the induced alternating voltage into direct current, the brushes help the current move, and the load uses the electrical energy generated by the stator.

**Types of DC Generator:**Based on their design, manner of excitation, and magnetic field makeup, DC generators can be divided into various types. Listed below are a few popular types of DC generators:

**1. Separately Excited DC Generator:** In a separately excited DC generator, the field magnets get their own supply of current from an outside source. An independent DC power supply powers the field winding, enabling fine control of the generator's output characteristics. In settings where precise control is necessary, such as in labs or research centers, this type of generator offers consistent voltage regulation. A form of separately stimulated direct current (DC) generator is one in which the field winding receives power from a different source, unrelated to the generator's output. The performance of the generator may be better controlled and regulated thanks to this independent power source. The stator, the rotor, the field winding, the armature winding, the brushes, and the commutator are the essential parts of a separately stimulated DC generator.

The magnetic field is produced when current runs through the field winding, which is commonly a coil of wire coiled around the stator's poles. A battery or another generator may be used to provide the field winding of a separately stimulated generator with DC power. Through independent control of the field current provided by this external power source, the generator's output can be precisely regulated. Another wire coil is found on the rotor and is known as the armature winding. Electromagnetic induction takes place while the rotor rotates in the magnetic field produced by the field winding, producing an electric current in the armature winding. The generator's output is this current. The commutator, a segmented cylindrical device attached to the rotor shaft, is in sliding contact with the brushes, which are conductive contacts. By converting the alternating current produced in the armature winding into direct current, the commutator functions as a mechanical rectifier.

The brushes keep in touch with the commutator segments, ensuring a single-direction flow of current. Excellent voltage regulation is one of the benefits of an independently excited DC generator. The magnetic field intensity can be adjusted by varying the current provided to the field winding, which leads to a more stable output voltage. This qualifies it for uses like those found in labs, research institutions, and some industrial processes where precise voltage control is necessary. The relationship between the field current, armature current, and generator speed of rotation can be used to estimate the output characteristics of a separately stimulated DC generator. The magnetic field is made stronger by increasing the field current, which results in a larger output voltage and improved control. In a similar vein, raising the armature current or rotational speed can boost the generator's output power. Separately excited DC generators do have certain restrictions, though. Because of their cooling and commutation capabilities' limits, they are often not suitable for high-power applications. At greater power levels, the commutation process, which involves the brushes and commutator to convert alternating current to direct current, becomes more difficult, increasing wear and sparking. Additionally, as power production rises, cooling the generator becomes more difficult. An independently excited DC generator, as the name implies, is a particular kind of DC generator in which the field winding receives power from a different source. The generator's output voltage may be precisely controlled because to this design's superior voltage regulation. The independently excited DC generator is frequently employed in circumstances where reliable and controlled DC power is required, despite potential limits in high-power applications.

**2. Self-Excited DC Generator:** With a self-excited DC generator, the generator's output serves as the source of the field current. Field excitation does not require an external power source for them. An instance of a direct current (DC) generator in which the field winding is powered by the generator's own output is known as a self-excited DC generator. The initial magnetic field necessary for functioning is produced using the electromagnetic induction principle. Series-wound, shunt-wound, and compound-wound generators are the three basic varieties of self-excited DC generators. Each variety has unique qualities and has a distinctive way of winding the field. Three sorts of self-excited DC generators can also be distinguished:

- a. Series-Wound DC Generator:** In a series-wound generator, the armature winding and field winding are linked in series. As a result, the load and the field winding both experience the same current flow. Due to their high beginning torque, series-wound generators are well suited for applications requiring a high initial torque, such as electric traction systems. The field winding and armature winding are linked in sequence in a generator that is wound in this way. This implies that the current travels through both windings at the same rate. The armature current creates a magnetic field through the series winding as the generator begins to rotate. A cumulative effect is created when this magnetic field reinforces the primary magnetic field generated by the stationary field poles. The series-wound generator offers a strong beginning torque and is appropriate for uses requiring a lot of starting power, including electric traction systems [7]–[9].
- b. Shunt-Wound DC Generator:** In a shunt-wound generator, the field winding and armature winding are linked in parallel. Compared to the armature winding, the field winding has a lot of turns and a comparatively high resistance. Shunt-wound generators offer good voltage regulation and a comparatively stable terminal voltage. They are frequently utilized in situations including homes, businesses, and factories where a reliable power source is

necessary. The field winding and armature winding are connected in parallel in a shunt-wound generator. The field winding has a higher resistance than the armature winding and is often made up of numerous rounds of thin wire. A magnetic field is produced as the generator runs because some of the armature current is directed to the field winding. Due to the relatively constant field current, the shunt-wound generator offers superior voltage regulation. It is frequently employed in situations where a constant and reliable output voltage is necessary, like electrical power distribution systems.

- c. Compound-Wound DC Generator:** These generators incorporate the advantages of both series- and shunt-wound designs. They have a shunt field winding as well as a series field winding. In comparison to series-wound generators, this arrangement offers superior voltage regulation and higher starting torque. In applications like electric power plants where a balance between voltage stability and starting performance is necessary, compound-wound generators are frequently used. Series and shunt field windings are both used in a compound-wound generator. It has two separate sets of field windings: a parallel shunt winding and a series winding coupled in series with the armature. The benefits of both series and shunt-wound generators are present in this design. In order to maintain a constant output voltage under fluctuating loads, the series winding increases the magnetic field intensity under high loads. When both good voltage management and a strong starting torque are necessary, the compound-wound generator is frequently used.

Self-excited DC generators are renowned for being straightforward and simple to use. They do, however, have some restrictions. As the magnetic field strength depends on the output current, they may have poor voltage regulation under variable loads. Furthermore, self-excited DC generators could have trouble starting, especially when a big initial current is needed. A self-excited DC generator is a kind of DC generator that powers the field winding with its own output. Series-wound, shunt-wound, and compound-wound generators are the three primary varieties of self-excited generators. Each variety is ideal for particular uses and has unique properties. Direct current electricity can be produced at a low cost with the help of self-excited DC generators, although they may have issues with starting and voltage regulation.

**3. Permanent Magnet DC Generator:** Instead of electromagnets, permanent magnets are used to create the magnetic field in a permanent magnet DC generator. These lightweight, portable generators are frequently utilized in small-scale applications that call for a moderate amount of power. Portable electronics, miniature wind turbines, and automotive applications all frequently use permanent magnet DC generators. A powerful magnet A direct current (DC) generator that uses permanent magnets to generate the necessary magnetic field is referred to as a DC generator, also referred to as a PMDC generator. PMDC generators, in contrast to other forms of DC generators, don't need field windings or an outside power source to produce the magnetic field. The stator (stationary part), rotor (spinning part), permanent magnets, armature winding, brushes, and commutator are the essential parts of a permanent magnet DC generator. Typically, a ferromagnetic core with slots to retain the armature winding makes up the stator of a PMDC generator. A coil of wire that has been twisted around the core and is attached to the external circuit is the armature winding. The permanent magnets, on the other hand, are housed inside the rotor. Neodymium or samarium cobalt are two common examples of high magnetic strength materials used to create permanent magnets. These magnets offer a consistent magnetic field since they are magnetized.

A stationary magnetic field is produced in the stator by the permanent magnets as the rotor rotates. Electromagnetic induction takes place in the armature winding while the rotor rotates in the magnetic field. According to Faraday's law of electromagnetic induction, this causes the induction of an electromotive force (EMF). Electricity is produced when a current flows through the armature winding as a result of the EMF. In order to transform the induced alternating current (AC) into direct current (DC), the brushes and commutator are essential components. The brushes maintain sliding contact with the segmented copper rings that make up the commutator, which is positioned on the rotor shaft. To guarantee that the output current is in a single direction (DC), the commutator rotates and periodically reverses the direction of current flow in the armature winding. Enduring magnet DC generators have a number of benefits. Compared to other kinds of generators, they have a small, lightweight design and a straightforward construction.

They are very dependable and suited for applications where a self-contained power supply is required because they don't have field windings or other power sources. Portable power supply, battery charging devices, and miniature wind turbines are just a few examples of small-scale applications that frequently make use of PMDC generators. PMDC generators do have certain restrictions, though. The magnetic field strength created by the permanent magnets is fixed and difficult to modify. This restricts the generator's output voltage regulation and control. A PMDC generator's ability to produce power is also constrained by how powerful the permanent magnets are, which could prevent it from being used in high-power applications. An overview of a permanent magnet Permanent magnets are used in a certain type of DC generator to produce the magnetic field needed to generate energy. They are appropriate for a variety of small-scale applications because of their simplicity, dependability, and compactness. When using PMDC generators, the fixed magnetic field strength and the constrained power output must be taken into account.

**4.Series-Parallel DC Generator:** A series-parallel DC generator is made up of several parallel-connected series-wound generators. The advantages of series-wound generators, such as a strong starting torque, are preserved while a larger power output is possible. Applications requiring high power output and dependable performance, including massive industrial processes or the production of electricity, frequently use series-parallel generators. A form of direct current (DC) generator known as a series-parallel DC generator combines the qualities of parallel- and series-wound generators. It is appropriate for a variety of applications since it is built to achieve a balance between strong starting torque and effective voltage management. Two sets of field windings series field winding and a shunt field winding make up the series-parallel DC generator. For the necessary performance, these windings are coupled in a series-parallel arrangement.

Similar to a series-wound generator, the series field winding and armature winding are coupled in series. The series field current can flow through both windings in this set up. When the generator is first turned on, the series winding creates a strong magnetic field that results in a high beginning torque. Comparable to a shunt-wound generator, the shunt field winding is linked in parallel with the armature winding. The shunt winding has a higher resistance than the series winding and is made up of numerous rounds of thin wire. By allowing a portion of the armature current to pass through the shunt winding in this design, the magnetic field intensity is increased overall. The advantages of both types of generators are provided by the combination of series

and shunt field windings. The series field winding produces a powerful magnetic field during startup, which enables the generator to deliver a large beginning torque. This qualifies the series-parallel DC generator for uses that demand an initial power surge, like heavy machinery or electric traction systems.

The shunt field winding is used once the generator is operating. The shunt winding modifies the magnetic field's intensity to adjust the output voltage. The generator can maintain a constant output voltage under various loads by regulating the shunt field current. This qualifies the series-parallel DC generator for uses such electrical power distribution systems that demand good voltage regulation. The series-parallel DC generator's adaptability is one of its benefits. A larger range of operating conditions and load requirements are possible with the combination of series and shunt windings. It offers both the voltage management of a shunt-wound generator and the high starting torque of a series-wound generator. The series-parallel DC generator does, however, have several drawbacks. Due to the complexity of the winding structure, careful planning and upkeep are required. Additionally, the performance of the generator may be impacted by changes in load circumstances, and field current regulation needs to be effectively handled to guarantee optimal performance. A series-parallel DC generator combines the advantages of shunt-wound and series generators. It is appropriate for a wide range of applications thanks to its high starting torque and efficient voltage regulation. The series-parallel DC generator is frequently employed in systems, such as electric vehicles, cranes, and industrial machines, where both high starting power and reliable voltage output are necessary. These are some of the most prevalent DC generator kinds, each with unique properties and useful applications. The required voltage regulation, starting torque, power output, and particular application requirements are only a few examples of the variables that influence the generator type selection.

**Application of DC Generators:**As a result of its capacity to transform mechanical energy into direct current, DC generators are used in a wide range of industries. Here are a few typical uses for DC generators:

- a. **Electricity Generation:** When a direct current power supply is required, DC generators are employed to produce electricity. They can be used in off-grid or isolated regions without access to the main power system. When converting generated alternating current (AC) into direct current (DC) for storage or immediate consumption, small-scale power plants, backup power systems, and renewable energy systems like solar and wind power frequently use DC generators.
- b. **Telecommunications:** Powering telecommunication systems is a crucial function of DC generators. Mobile base stations, signal repeaters, and distant communication towers are all powered by them. Particularly in locations without reliable or limited access to the grid, these systems frequently need a consistent and dependable source of direct current to function.
- c. **Automotive Industry:** To charge the battery and power the electrical systems in cars, DC generators, also referred to as alternators, are widely employed. In order to replenish the battery and power the different electrical parts of the car, such as lights, ignition systems, and entertainment systems, the alternator transforms mechanical energy from the engine into electrical energy [10].



- d. **Industrial Processes:** DC generators have a variety of uses in industry. They are employed in electroplating processes, which involve applying metal coatings on surfaces using a regulated direct current. The direct current required for arc welding and other welding procedures is provided by DC generators, which are also used in welding operations.
- e. **Railway Systems:** Historically, DC generators have been crucial to the operation of railway systems. They were used to provide the traction motors and other onboard electrical equipment with electricity for electric trains. While many contemporary railway systems now use AC power, some older systems and particular applications continue to run on DC generators.
- f. **Research and Laboratory Equipment:** DC generators are a common piece of equipment in research institutions and laboratories. They offer a reliable and controlled source of direct current for use in tests, experiments, and scientific apparatus. Accurate measurements and study inquiries are made possible by the precise control that researchers have over the voltage, current, and power output thanks to DC generators.
- g. **Battery Charging:** DC generators are used in applications that include battery charging. Batteries in many different systems, such as those in cars, boats, RVs, and renewable energy systems, are recharged using them. Direct current that is steady and well-regulated can be supplied by DC generators to effectively charge the batteries.
- h. **Aerospace and Aviation Applications:** DC generators are used to power a variety of electrical equipment onboard airplanes, satellites, and spacecraft. They are essential for supplying avionics, communication systems, navigational equipment, and other electronic components with electrical power.

These are only a handful of the numerous uses for which DC generators are put to use. They are vital in a variety of industries and fields where a stable and controlled electrical power source is needed due to their adaptability, dependability, and capacity to deliver direct current.

**Losses in DC Generator:** Different kinds of losses occur while DC generators are in operation. The generator's overall effectiveness and performance are impacted by these losses. Here are a few typical loss kinds in DC generators:

1. **Copper Losses:**  $I^2R$  losses, commonly referred to as copper losses, are brought on by the resistance of the field and armature windings. When current passes through the windings, resistance results in heat being produced as power is lost. By reducing resistance in the design and utilizing materials with low resistivity, these losses can be reduced to a minimum.
2. **Iron Losses:** The magnetic core of the generator experiences iron losses, also known as core losses or magnetic losses. Hysteresis loss and eddy current loss are the two parts that make up these losses. The energy lost during hysteresis is a result of the core material's reversal of magnetization as the magnetic field changes direction. When circulating currents are induced in the core material, resistive losses result, which is known as eddy current loss. High-quality laminated iron cores are used to help cut down on these losses.
3. **Brush Contact or Brush-Contact Resistance Losses:** Resistance losses can be caused by brush contact or brush-contact when the brushes of a DC generator make contact with the commutator segments. Heat is produced when there is insufficient contact between the

brushes and the commutator. To reduce these losses, it's critical to maintain adequate brush contact and to frequently inspect and replace brushes.

4. **Losses from windage and friction:** Losses from windage result from the mechanical resistance that the generator's rotating parts like the rotor or armature experience as they move through the air. The interaction between various rotating parts and stationary parts, like bearings, causes friction losses. High-quality bearings, appropriate lubrication, and effective rotating component design can all help to cut down on these losses.
5. **Stray Load Losses:** Magnetic flux leaks within the generator cause losses known as stray load losses. Energy is lost when a portion of the magnetic flux does not connect with the armature winding. By carefully planning and insulating the magnetic circuit to keep the magnetic flux on the intended route, these losses can be reduced.
6. **Mechanical and Brush Mechanical Losses:** In a DC generator, mechanical losses are brought on by the mechanical friction and mechanical resistance that various rotating components must overcome. These losses include friction from bearings, brushes, and air. Regular maintenance, effective design, and appropriate lubrication reduce these losses.

A DC generator's efficiency is a crucial performance factor; hence attempts are made to lower these losses in order to boost total efficiency. In order to reduce losses and increase a DC generator's efficiency, design optimization, material choice, and routine maintenance are essential.

## CONCLUSION

The crucial machinery that enables the transformation of mechanical energy into electrical energy is the DC generator. They function according to the electromagnetic induction principle, which states that a conductor's motion within a magnetic field causes an induced voltage across the conductor. The rotor, stator, commutator, brushes, and load are the major elements of a DC generator. DC generators may deliver a consistent output of direct current by maintaining a constant magnetic field and rotational speed. DC generators are widely used in many industries, including the production of energy, where they act as the main source of electricity. They are used in electric automobiles as well, transforming the engine's mechanical energy into electrical energy to run the car's systems. Additionally, DC generators are used in industrial operations like welding, electroplating, and electrolysis that call for a consistent and controlled DC power source. To sum up, DC generators are essential tools that allow mechanical energy to be transformed into electrical energy. They are vital in a variety of applications across many industries due to their adaptability and capacity to deliver a steady supply of direct current. Future DC generator technology advances are anticipated to further improve their overall performance, dependability, and efficiency.

## REFERENCES:

- [1] V. Madonna, P. Giangrande, and M. Galea, "Electrical Power Generation in Aircraft: Review, Challenges, and Opportunities," *IEEE Trans. Transp. Electrification*, 2018, doi: 10.1109/TTE.2018.2834142.
- [2] I. Boldea, "Electric generators and motors: An overview," *CES Trans. Electr. Mach. Syst.*, 2020, doi: 10.23919/tems.2017.7911104.

- [3] R. Prenc, A. Cuculić, and I. Baumgartner, “Advantages of using a DC power system on board ship,” *J. Marit. Transp. Sci.*, 2016, doi: 10.18048/2016.52.05.
- [4] O. A. Ahmed and J. A. M. Bleijs, “An overview of DC-DC converter topologies for fuel cell-ultracapacitor hybrid distribution system,” *Renewable and Sustainable Energy Reviews*. 2015. doi: 10.1016/j.rser.2014.10.067.
- [5] S. Castellan, R. Menis, A. Tessarolo, F. Luise, and T. Mazzuca, “A review of power electronics equipment for all-electric ship MVDC power systems,” *International Journal of Electrical Power and Energy Systems*. 2018. doi: 10.1016/j.ijepes.2017.09.040.
- [6] Z. R. Labidi, H. Schulte, and A. Mami, “A Model-Based Approach of DC-DC Converters Dedicated to Controller Design Applications for Photovoltaic Generators,” *Eng. Technol. Appl. Sci. Res.*, 2019, doi: 10.48084/etasr.2829.
- [7] R. Yang, R. Xu, W. Dou, M. Benner, Q. Zhang, and J. Liu, “Semiconductor-based dynamic heterojunctions as an emerging strategy for high direct-current mechanical energy harvesting,” *Nano Energy*. 2021. doi: 10.1016/j.nanoen.2021.105849.
- [8] M. Chai, B. D. Reddy, S. Lingeswaren, S. K. Panda, D. Wu, and X. Chen, “Progressing towards DC electrical systems for marine vessels,” in *Energy Procedia*, 2017. doi: 10.1016/j.egypro.2017.12.643.
- [9] K. A. Kaczmarek, “The tongue display unit (TDU) for electrotactile spatiotemporal pattern presentation,” *Scientia Iranica*. 2011. doi: 10.1016/j.scient.2011.08.020.
- [10] J. Shair, H. Li, J. Hu, and X. Xie, “Power system stability issues, classifications and research prospects in the context of high-penetration of renewables and power electronics,” *Renewable and Sustainable Energy Reviews*. 2021. doi: 10.1016/j.rser.2021.111111.

## CLASSIFICATION OF DIRECT CURRENT MOTORS

**Mrs. Ragasudha Chundampunathil\***

\*Assistant Professor,  
Department of Electrical And Electronics Engineering,  
Presidency University, Bangalore, INDIA  
Email Id-ragasudha@presidencyuniversity.in

---

### ABSTRACT:

*An electrical motor known as a DC (Direct Current) motor transforms electrical energy into mechanical energy by interacting with magnetic fields. Since their creation, DC motors have been widely used in several applications and have been essential to the advancement of contemporary technologies. Electric automobiles to industrial automation systems all use DC motors in various applications. An overview of DC motors is given in this chapter, along with information on kinds, uses, and benefits. The purpose is to present a thorough grasp of DC motors and their importance in various sectors.*

**KEYWORDS:** *Brushed Dc Motor, Brushless Dc Motor, Compound Dc Motor, Differential Compound Dc-Motor, Series Field Winding.*

---

### INTRODUCTION

An electrical device known as a DC (Direct Current) motor transforms electrical energy into mechanical energy. It is frequently used in a variety of applications, including robotics, commercial machinery, electric cars, and more. It functions on the idea of electromagnetic induction. The stator, rotor, commutator, and brushes are the main elements of a DC motor. A stationary magnetic field created by electromagnetic windings or permanent magnets makes up the stator. On the other hand, the rotor, which rotates with the motor, is where the armature winding is located. A magnetic field is produced inside the stator when a DC voltage, referred to as the input voltage ( $V_{in}$ ), is applied to the motor. The rotor rotates as a result of the torque produced by the magnetic field interaction between the armature winding and the stator. The commutator is a multi-segmented cylindrical structure that is connected to the rotor and is typically composed of copper. The commutator segments are in touch with the brushes, which are commonly formed of carbon or graphite.

They serve as the electrical link between the armature winding and the power supply. The commutator segments make contact with the brushes as the rotor rotates, which changes the direction of the current flowing through the armature winding. The rotor will continue to rotate in the same direction as a result of the current being reversed. Brushed DC motors and brushless DC motors are the two primary types of DC motors. While brushless motors employ electronic circuits and permanent magnets to accomplish the same task, brushed motors use the commutator and brushes to change the direction of current flow. The ability of DC motors to deliver accurate speed control and torque regulation is one of their key benefits. The speed and torque characteristics can be carefully regulated by altering the input voltage or the current passing through the motor. DC motors are appropriate for applications demanding swift acceleration or heavy loads because they also have a strong starting torque. In addition, compared to other motor

types, they are often smaller, lighter, and more affordable. DC motors do have certain limits, though. Regular maintenance is necessary for the brushes in brushed DC motors since they can eventually cause mechanical and electrical wear. By doing away with the brushes, brushless DC motors get over this problem, resulting in less maintenance and better durability. The dependability, controllability, and versatility of DC motors make them popular across a range of sectors[1]–[3]. DC motors are essential for transferring electrical energy into mechanical motion, whether they are powering a little toy or a massive industrial equipment.

**Working Principle of DC Motor:**Based on the interactions of a magnetic field and an electric current, electromagnetism governs the operation of a DC (direct current) motor. To create rotating motion, it transforms electrical energy into mechanical energy. The idea of Lorentz force can be used to describe the fundamental operation of a DC motor. The stator, which is stationary, and the rotor, which rotates, are the two primary components of the motor.

- a. **Stator:** A permanent magnet or an electromagnet that produces a static magnetic field makes up the stator. It is in charge of producing a magnetic field that engages the rotor.
- b. **Rotor:** The rotor is made up of a wire coil wound around a core and a shaft. The stator contains the rotor, which is free to spin. Whenever an electric current flows through it, it behaves like an electromagnet.

A current flow through the rotor coil when a DC voltage is provided to the motor. This current creates a magnetic field around the rotor coil using Ampere's right-hand rule. A force known as the Lorentz force is produced by the interaction of the magnetic fields of the rotor and stator. The rotor experiences a torque as a result of the Lorentz force, which then results in rotational motion. A commutator and brushes arrangement controls the direction of the current flow in the rotor coil, ensuring that the direction of the magnetic field in the rotor changes at the right moments. A split metal ring that is attached to the rotor coil makes up the commutator. As the rotor rotates, carbon brushes make direct contact with the commutator segments, allowing current to pass across various segments. As a result, there is constant rotation because the magnetic fields in the rotor and stator are always in alignment. The amount and polarity of the applied voltage can be changed to regulate the DC motor's speed and direction. The motor's speed and torque can be changed to suit different applications by changing the voltage or adding extra control circuits. In general, the production of a magnetic field by the interaction of current-carrying conductors with electro- or permanent magnets produces rotational motion in a DC motor.

**Construction of Brushed DC Motor:**A motor that uses direct current (DC) transforms electrical energy into mechanical energy to create rotating motion. It consists of the stator, rotor, commutator, brushes, and housing, among other essential parts. Let's examine a DC motor's design in greater detail.

- a. **Stator:** The stator, which is the motor's stationary component, is often composed of a metal frame or core. It holds the field windings, which are typically soft steel or iron laminations wrapped in copper wire. A static magnetic field is created by the field windings and interacts with the rotor to propel rotation.
- b. **Rotor:** The motor's rotating component, the rotor is attached to the shaft. The armature windings are carried by a laminated iron core. Copper wire is used for the armature windings,



which are wrapped around the core. When current passes through the rotor windings, they behave like electromagnets and produce a magnetic field that interacts with the magnetic field of the stator.

- c. **Commutator:** Mounted on the rotor shaft, the commutator is a cylindrical object. It is constructed of copper segments that are isolated from one another. Usually, the number of armature windings equals the number of segments. As the rotor rotates, the commutator permits current to flow into and out of the armature windings. Additionally, it makes sure that the current changes direction when it needs to in order to maintain constant rotation.
- d. **Brushes:** The brushes are blocks of carbon or graphite that transmit electricity and come into direct touch with the commutator segments. Typically, they are spring-loaded to maintain reliable contact. Through the commutator, the brushes transmit current from the power source to the armature windings. In order to provide appropriate electrical connection and current flow, the brushes are essential.
- e. **Housing:** The motor is contained in a housing that supports and protects its internal parts. A non-magnetic material, like steel or aluminum, is often used to create the housing. Additionally, it offers a framework for attaching the motor and could have cooling components like vents or fins to release heat produced during operation.

**Working Principle:** A magnetic field is produced when a DC voltage is provided to the motor, causing current flow through the stator's field windings. In parallel, current passes through the rotor's armature windings, producing a second magnetic field. The Lorentz force is created as a result of the magnetic fields of the stator and rotor interacting. The rotor experiences a torque as a result of the Lorentz force, which generates rotational motion. The commutator segments make contact with the brushes as the rotor turns, which changes the direction of the current flowing through the armature windings. By ensuring that the magnetic fields in the rotor and stator are always in line with one another, continuous rotation is made possible. The magnitude and polarity of the applied voltage can be changed, as well as the use of additional control circuits, to alter the motor's speed and direction. The motor's speed and torque can be controlled to fit certain applications by altering the voltage or managing the current flow. A stator, rotor, commutator, brushes, and casing make up a DC motor. The field windings are carried by the stator, whilst the armature windings are carried by the rotor. The commutator and brushes allow current to be transferred to the armature windings, producing rotational motion and a revolving magnetic field. The housing supports and shields the internal parts of the motor. The applied voltage can be changed, or control circuits can be used, to alter the motor's speed and direction.

**Construction of Brushless DC Motor:** Brushless DC (BLDC) motors are a kind of DC motor that improve efficiency and dependability by doing away with the requirement for brushes and commutators. They are extensively employed in many different fields, including as aircraft, electric vehicles, and industrial automation. The following crucial parts are used in brushless DC motor construction:

- a. **Stator:** The stator, which houses the stator windings, is the stationary component of a brushless DC motor. Several coils are often coiled around laminated iron cores. The number of stator windings and the motor's pole count are correlated. Typically, the stator windings are three-phase windings that are organized in a star (Y) or delta pattern. When these windings are activated by an outside power source, a revolving magnetic field result.

- b. Rotor:** Permanent magnets are found in the brushless DC motor's rotating component, or rotor. The permanent magnets can either be integrated into the rotor or installed on the surface of the rotor. The number of poles in the stator and the number of rotor magnets are correlated. The rotor rotates as a result of an interaction between the magnetic poles of the rotor magnets and the revolving magnetic field produced by the stator windings.
- c. Hall Effect Sensors:** Mounted on the stator, Hall effect sensors are a feature of brushless DC motors. The location of the rotor magnets is determined via hall effect sensors. They give the motor controller feedback, allowing for precise control of the motor's performance. Normally, the Hall effect sensors are fixedly arranged and equally spaced all around the stator. The motor design and the desired degree of position sensing precision determine how many Hall effect sensors are needed.
- d. Motor Controller:** A key element of brushless DC motors is the motor controller. It is in charge of regulating the power supply to the stator windings depending on the information the Hall effect sensors provide. The time and order of energizing the stator windings are chosen by the motor controller using electrical circuitry and algorithms. The motor controller can synchronize the position of the rotor with the rotating magnetic field, leading to efficient and smooth motor operation, by precisely managing the power supply to the windings.
- e. Optional Enclosure:** Brushless DC motors may be housed in a protective housing or casing in some situations. The enclosure offers the motor components physical security and could also have features for heat dissipation, noise cancellation, and ingress security.

In general, the integration of stator windings, rotor magnets, Hall effect sensors, and a motor controller is required for brushless DC motor development. By doing away with brushes and commutators, this design provides enhanced efficiency, dependability, and precise control in a variety of applications[4]–[6].

## DISCUSSION

### Types of DC Motors

Based on their design, performance traits, and intended uses, DC motors can be divided into a number of categories. Following are a few popular types of DC motors:

**1.Brushed DC Motors:** The most popular kind are brushed DC motors, commonly referred to as conventional or classic DC motors. They include an armature-powering rotor with a commutator and carbon brushes. Rotational motion is produced when the commutator changes the direction of current flow in the armature coil. Brushed DC motors are renowned for being straightforward and affordable. Direct current (DC) electric motors, sometimes referred to as commutator motors, include brushed DC motors. Due to their controllability, affordability, and simplicity, they are frequently employed in a variety of applications. A stator, rotor, brushes, commutator, and armature winding are among the essential parts of a brushed DC motor's fundamental structure. The stator, which is the motor's stationary component, is commonly made of permanent magnets or electromagnets.

The force required for motor operation is generated by the magnetic field that the stator produces. The motor's rotating component, known as the rotor, is attached to the output shaft. The armature winding, a collection of wire windings, interacts with the magnetic field generated

by the stator. The current that creates the magnetic field on the rotor is carried by the armature winding. The conductive contacts on the brushes slide against the commutator. They are in charge of supplying electrical current to the rotor windings and are often constructed of carbon or graphite. The rotor shaft is home to the segmented cylindrical commutator. It is made up of distinct copper segments that are spaced apart by insulation. In order to maintain proper current flow, the brushes must remain in contact with the commutator segments. An interaction between the magnetic field generated by the stator and the current flowing through the armature winding is necessary for a brushed DC motor to function. The armature winding generates an electromagnetic field that interacts with the magnetic field of the stator as current runs through it.

The force produced by this engagement propels the rotor into rotation. A crucial part in turning the applied DC voltage into spinning motion is played by the commutator. The brushes and commutator change the direction of current flow in the armature winding as the rotor rotates, ensuring that the magnetic field is constantly aligned with the field of the stator and producing continuous spinning. Brushed DC motors have a number of benefits. Comparatively speaking to other motor kinds, they are relatively cheap and simple. They are useful for applications that need precision control, such as robotics, industrial machinery, and automotive systems, because of their construction, which makes it simple to manage speed and torque. In addition to having a strong beginning torque, brushed DC motors have a significant power output. Brushed DC motors can have restrictions, too. Over time, the brushes and commutator deteriorate and need regular maintenance or replacement.

Additionally, inefficiencies like heat generation and energy losses may result from mechanical friction between the brushes and commutator. Furthermore, due to mechanical restrictions, brushed DC motors are typically not appropriate for high-speed applications. Since they outperform brushed DC motors in terms of efficiency, dependability, and maintenance needs, brushless DC motors (BLDC) have grown in popularity in recent years. BLDC motors are better suited for contemporary applications since they use electronic commutation rather than brushes and commutators. In conclusion, brushed direct-current (DC) motors are a common type of electric motor. They are made up of brushes, a commutator, a rotor with an armature winding, and a stator. Compared to brushless DC motors, these motors are less suitable for high-speed applications and offer simplicity, controllability, and cost.

**2.Brushless DC Motors:** Due to their increased dependability and efficiency, brushless DC motors (BLDC motors) have become more common. They energize the stator windings using electronic controllers, which eliminates the need for brushes and commutators. A brushless DC motor's rotor is typically made of permanent magnets. In comparison to brushed DC motors, BLDC motors have benefits including improved efficiency, a longer lifespan, and less maintenance. They are frequently employed in systems that need for precise control, such as industrial automation, robotics, and electric cars. Electric motors that use electronic commutation rather than brushes and a commutator are referred to as brushless DC motors (BLDC), also known as electronically commutated motors (ECMs). They are superior to brushed DC motors in terms of efficiency, dependability, and controllability. Consumer electronics, industrial machinery, and automotive systems are just a few of the fields and applications where BLDC motors are finding increasing use.

A stator, a rotor, plus a collection of sensors and electronics for commutation control make up a brushless DC motor. A precise design of stationary windings is used to construct the stator. The electronic control system determines the order in which these windings are powered on. On the other hand, the rotor is made of permanent magnets, which establish a constant magnetic field. A BLDC motor's rotor has no windings, unlike brushed DC motors. Reduced mechanical friction and wear results from the rotor's lack of windings since brushes and commutators are no longer necessary. Sensors and electrical circuits are frequently used in conjunction to control the commutation in BLDC motors. For instance, Hall effect sensors are frequently employed to determine where the rotor magnets are located. By providing feedback to the control system, these sensors enable it to precisely time and order the current commutation in the stator windings. This electrical commutation makes sure that the magnetic field lines up with the location of the rotor, allowing for effective and seamless functioning. Brushless DC motors have a number of benefits over brushed DC motors. First off, BLDC motors are more efficient since they don't have brushes or commutators, which lowers energy losses and gets rid of the mechanical friction those parts cause.

Improved performance, lessened power usage, and extended operational life are all results of this efficiency. Brushless DC motors, on the other hand, provide accurate speed and torque control. Robotics, CNC machines, and medical equipment, which require precise motion control, can all benefit from the electronic commutation system's ability to control motor settings precisely and quickly. Thirdly, BLDC motors are renowned for being dependable and long-lasting. Because there are no brushes, problems with brush wear, arcing, and sparking are eliminated, resulting in less maintenance and a longer motor lifespan. Electronic commutation also enables a quieter performance, less vibration, and smoother functioning. In addition, compared to brushed DC motors, brushless motors may run at higher speeds. The mechanical restrictions imposed by brushes and commutators are eliminated by their absence, allowing BLDC motors to operate at higher rotational speeds. Brushless DC motors have a few drawbacks despite their many benefits.

They often rely on electronic speed controllers (ESCs) to control the commutation process and need more complicated control circuits. When compared to brushed DC motors, this complexity may result in higher starting costs. Additionally, to dissipate the heat produced by the stator windings, brushless DC motors could need extra cooling components like fans or heat sinks. Brushless DC motors are electric motors with precise control, increased effectiveness, and little maintenance thanks to electronic commutation. In comparison to brushed DC motors, they are more efficient, dependable, controllable, and capable of higher speeds. Because of these qualities, BLDC motors are frequently used in a variety of applications where accurate and effective motor control is necessary.

**3.Series DC Motors:** In series DC motors, the armature and field windings are connected. High starting torque and a low-speed characteristic are produced by this design. For applications requiring a strong beginning torque, including electric traction, forklifts, and hoists, series motors are noted for their ability to deliver a high torque even at low speeds. Their speed regulation, meanwhile, could not be as accurate as that of other DC motor types. A form of direct current (DC) electric motor known as a series DC motor is one in which the armature and field windings are connected in series. Due to their strong starting torque, simplicity, and durability, these motors are frequently utilized in a variety of applications. A stator, a rotor, field windings,

armature windings, brushes, and a commutator make up the assembly of a series DC motor. The field windings are normally housed in the stator, which is the stationary component of the motor.

The stator poles are wrapped in the field windings, which are formed of several wire turns. A magnetic field is produced by the field windings as electricity passes through them. The revolving component of the motor is the rotor, sometimes referred to as the armature, and it is attached to the output shaft. It is made up of armature windings, which are wire windings. The magnetic field created by the field windings interacts with these windings, creating a torque that turns the rotor. The brushes, which are normally constructed of graphite or carbon, keep sliding contact with the commutator. The rotor shaft is home to the segmented cylindrical commutator. It is made up of copper pieces that are isolated from one another. By periodically switching the flow of current in the armature windings, the brushes and commutator are in charge of turning the input DC voltage into a spinning motion. The operation of series DC motors is dependent on the electromagnetic interaction of the magnetic fields produced by the armature and field windings.

The magnetic field produced by the series windings as current flows through them interacts with the magnetic field produced by the armature windings. The force created by this engagement propels the rotor into rotation. The high starting torque of series DC motors is one of their distinguishing features. The field and armature windings are set up in series, allowing the armature current to pass through both windings. As a result of the increased armature current, the magnetic field generated by the field windings becomes stronger, which raises the torque at startup. DC motors in series are renowned for their superb speed regulation. A higher magnetic field and relatively constant speed are produced as the load increases and the armature current increases. This qualifies series DC motors for uses including electric vehicles, locomotives, and heavy equipment that require constant speed control under a variety of load circumstances.

Series DC motors can have restrictions, though. Due to the high current passing through the windings, they may experience decreased efficiency at low loads. Additionally, because speed rises with decreasing load, controlling their speed might be difficult. In order to efficiently manage the speed, additional control mechanisms are needed, such as external resistors or electronic speed control. Series DC motors are electric motors with a series connection between the armature and field windings. They are sturdy, have a high beginning torque, and have superb speed regulation. The efficiency and speed control of series DC motors may be constrained when used with light loads, but they are frequently utilized in applications where strong torque and reliable speed control are necessary[7], [8].

**4. Shunt DC Motors:** DC motors with a shunt connection between the armature and field windings are known as shunt motors. Compared to series motors, shunt motors have a steadier speed characteristic. They are frequently used in equipment like industrial pumps, conveyor belts, and tools that need to run at a steady speed. Shunt motors are renowned for their consistent performance and good speed regulation. Shunt Electric motors that run on direct current (DC) are known as DC motors, and they are distinguished by having the field and armature windings connected in parallel, or shunt. These motors' simplicity, controllability, and versatility make them popular in a wide range of applications. A shunt DC motor is made up of a number of essential parts, including a stator, rotor, field windings, armature windings, brushes, and



commutator. The field windings are normally housed in the stator, which is the stationary component of the motor.

The stator poles are wrapped in the field windings, which are formed of several wire turns. A magnetic field is produced by the field windings as electricity passes through them. The revolving component of the motor is the rotor, sometimes referred to as the armature, and it is attached to the output shaft. It is made up of armature windings, which are wire windings. The magnetic field created by the field windings interacts with these windings, creating a torque that turns the rotor. The brushes, which are normally constructed of graphite or carbon, keep sliding contact with the commutator. The rotor shaft is home to the segmented cylindrical commutator. It is made up of copper pieces that are isolated from one another. By switching the flow of current in the armature windings, the brushes and commutator are in charge of turning the input DC voltage into a spinning motion. The operation of shunt DC motors is based on the electromagnetic interaction of the magnetic fields produced by the armature windings and field windings. The magnetic fields generated by the parallel-connected field and armature windings interact when current passes through them. Due to the field windings' parallel connection to the armature, the magnetic field it produces is essentially constant. The rotor rotates because of the torque produced by the force this constant magnetic field exerts on the armature windings. Shunt DC motors have a number of benefits.

They offer good speed regulation, which means that even with increasing loads, the speed remains largely constant. This qualifies them for uses including conveyors, machine tools, and pumps that need reliable speed control. Shunt DC motors also provide a variety of speed control options. The speed of the motor can be changed by altering the voltage provided to the armature windings. Because of this, they are flexible to a variety of operating environments. Shunt DC motors are also excellent for a variety of applications due to their great efficiency and ability to run at both high and low speeds. Shunt DC motors do have certain limits, though. Compared to other motor types, they frequently have lesser starting torque, which may need the use of extra devices, like a starting winding or a different starting motor, for applications requiring strong starting torque. Shunt DC motors are electric motors with parallel connections between the armature and field windings. They are versatile, have a wide speed control range, and provide good speed regulation. Shunt DC motors are frequently employed in applications where reliable speed control and adaptability to various operating circumstances are necessary.

**5.Compound DC Motors:** Series and shunt motor characteristics are combined in compound DC motors. They have a shunt field winding as well as a series field winding. Cumulative compound motors and differential compound motors are two other varieties of compound motors. The characteristics of both series DC motors and shunt DC motors are combined in compound DC motors, also referred to as compound-wound DC motors. They have parallel connections between a series field winding and a shunt field winding. Compound DC motors can now offer the benefits of both series and shunt motors thanks to this combination. Similar to shunt DC motors, compound DC motors are built similarly. Its components include a rotor, a stator, brushes, commutator, and field windings. The field windings are normally housed in the stator, which is the stationary component of the motor.

There are two different sets of field windings for compound DC motors: a series field winding and a shunt field winding. The armature winding and the series field winding are coupled in

series. It is made up of a few rounds of strong wire and is intended to transport a sizable amount of electricity. Strong magnetic fields are generated by the series field winding, which results in high beginning torque and the capacity to carry big loads. The armature winding and the shunt field winding are coupled in parallel. It is built to carry a relatively low current and is composed of numerous rounds of tiny wire. The shunt field winding creates a magnetic field that is largely continuous and effectively controls and regulates speed. The motor's rotating component, known as the rotor or armature, is attached to the output shaft. It is made up of armature windings, which are wire windings. The magnetic fields created by the series and shunt field windings interact with the armature windings to produce torque that turns the rotor. The commutator, a segmented cylindrical device positioned on the rotor shaft, is kept in sliding contact with the brushes using this mechanism.

The commutator and brushes reverse the direction of current flow in the armature windings to turn the applied DC voltage into a rotational motion. Series and shunt field windings work together to affect how a compound DC motor operates. Applications requiring heavy load starts can benefit from the series field winding's strong starting torque. The motor maintains a comparatively consistent speed under varying load situations because to the shunt field winding's effective speed regulation. Cumulative compound and differential compound are the two categories into which compound DC motors can be divided. The series field winding and the shunt field winding work together to strengthen the magnetic field in a cumulative compound motor. In applications like hoists, elevators, and heavy machines, this type of motor has a strong starting torque. The series field winding and the shunt field winding compete with one another in a differential compound motor, weakening the magnetic field. A compromise between high beginning torque and accurate speed regulation is offered by this kind of motor.

In applications like fans, blowers, and machine tools that need a moderate starting torque and speed control, differential compound motors are employed. Compound DC motors provide high starting torque and excellent speed regulation, combining the benefits of both series and shunt motors. But they also have some things to take into account. Additional maintenance and careful management may be necessary due to the intricacy of the motor design and the requirement for exact balancing between the series and shunt fields. Compound DC motors, in essence, are electric motors that combine the advantages of shunt and series motors. They have a parallel connection between a shunt field winding and a series field winding. Compound DC motors are well suited for a variety of applications demanding both heavy load starts and speed control and offer high starting torque and good speed regulation.

**a.Cumulative Compound Motors:** The series field winding aids the shunt field winding in cumulative compound motors, increasing torque. These motors are frequently used in equipment like rolling mills, elevators, and heavy machinery that needs high starting torque and good speed regulation. When the series field winding and the shunt field winding work together, a compound DC motor is said to be cumulative. A higher magnetic field is produced by this design, resulting in greater starting torque and enhanced load carrying capacity. The series field winding and the shunt field winding are connected in parallel in a cumulative compound motor. A few turns of thick wire are used in the series field winding, which carries a sizable amount of current. It generates a magnetic field whose strength depends on the armature current.

On the other hand, the shunt field winding carries a little amount of current and is made up of numerous turns of fine wire. It generates a magnetic field that is generally steady. In a cumulative compound motor, the series and shunt field windings work together to increase the magnetic field as a whole. Due to its high current, the series field winding considerably increases the strength of the magnetic field as a whole. This produces a motor with a strong beginning torque that is appropriate for applications where the motor must start while carrying heavy loads. Cumulative compound motors' high starting torque is especially useful in applications like hoists, cranes, elevators, and heavy machinery where the motor must overcome initial resistance or inertia. Cumulative compound motors also have the advantage of being able to carry heavier loads without experiencing a major speed reduction. The armature current increases together with the load placed on the motor. As a result, the magnetic field produced by the series field winding is strengthened. By making up for the increased load, the magnetic field is raised, enabling the motor to run at a reasonably constant speed. The relatively constrained speed control range of cumulative compound motors is one disadvantage, though.

The motor's speed tends to drop as the load rises because of the robust series field winding. Their suitability in applications requiring accurate speed control over a large range may be limited by this trait. Additional control methods, such as variable voltage control or electronic speed controllers, can be used to more efficiently modify the voltage provided to the motor and manage its speed in order to lessen the impact of this constraint. To sum up, cumulative compound motors are compound DC motors with parallel connections connecting the series field winding and the shunt field winding, which support one another. They are suitable for applications that demand heavy load starts and constant speed under fluctuating loads because they have high starting torque and improved load handling capabilities. Their range of speed regulation, however, might be constrained, necessitating the use of additional control mechanisms for exact speed regulation.

**b. Differential Compound Motors:** Differential compound motors provide a more consistent speed characteristic because the series field winding opposes the shunt field winding. Differential compound motors are used in places like paper mills and printing presses where a steady speed under fluctuating loads is necessary. Compound DC motors called differential compound motors have a series field winding and a shunt field winding that are in opposition to one another. In comparison to the cumulative compound motor, this configuration produces a weaker magnetic field and offers a balance between high beginning torque and effective speed regulation. The series field winding and the shunt field winding are connected in parallel in a differential compound motor. Their polarities are in opposition to one another, nevertheless. A few turns of thick wire are used in the series field winding, which carries a sizable amount of current. In contrast to the shunt field winding, it creates a magnetic field that is proportionate to the armature current but points in the other direction.

On the other hand, the shunt field winding carries a little amount of current and is made up of numerous turns of fine wire. In contrast to the series field winding, it generates a magnetic field that is roughly constant but points in the wrong direction. In a differential compound motor, the combined impact of the series and shunt field windings causes their magnetic fields to partially cancel one another. As a result, in comparison to a cumulative compound motor, the overall magnetic field is weaker. Differential compound motors provide a compromise between strong speed regulation and high beginning torque. When compared to a series motor, a motor with

opposing magnetic fields created by the series and shunt field windings exhibits less speed variation under varied loads. Due to this, differential compound motors are appropriate for applications requiring a good amount of speed control and a moderate beginning torque. Diverse industries use differential compound motors for things like fans, blowers, machine tools, and conveyor systems.

They offer a larger working range compared to a pure series or shunt motor because they strike a balance between the traits of the two types of motors. Differential compound motors have the advantage of being able to tolerate small variations in load without experiencing large speed fluctuations. As the load changes, the opposing magnetic fields aid in preserving a largely constant speed. It's crucial to remember that differential compound motors might not offer cumulative compound motors the same beginning torque. In comparison to a cumulative compound motor, the opposing field windings decreased magnetic field reduces the beginning torque. Differential compound motors are compound DC motors with parallel connections between the series field winding and the shunt field winding but distinct polarity. They are suitable for applications that need for moderate starting torque and reasonable speed control because they offer a balance between high beginning torque and good speed regulation. Compared to series motors, they offer greater speed management even though they do not have the same high beginning torque as cumulative compound motors[9], [10].

**c. Permanent Magnet DC Motors:** a constant magnet A permanent magnet DC motor Permanent magnets are used on the rotor of DC (PMDC) motors rather than field windings. The armature winding of the stator interacts with the permanent magnets' magnetic field to produce rotation. Because of their small size, great efficiency, and consistent performance, PMDC motors are well-known. Small appliances, fans, toys, and automotive applications all frequently use them. a DC permanent magnet (PMDC) motors are electric motors that create the magnetic field required for their operation using permanent magnets. Due to their small size, excellent efficiency, and simplicity, these motors are widely used. A stator, a rotor, permanent magnets, armature windings, brushes, and a commutator are among the essential parts of a PMDC motor. The field poles are normally housed in the stator, which is the stationary component of the motor. A steady magnetic field is produced by permanent magnets found inside the field poles.

The revolving component of the motor is the rotor, sometimes referred to as the armature, and it is attached to the output shaft. It consists of an armature winding and a ferromagnetic material core. The magnetic field produced by the permanent magnets interacts with the armature windings to produce torque, which turns the rotor. The commutator, a segmented cylindrical device positioned on the rotor shaft, is kept in sliding contact with the brushes using this mechanism. The commutator and brushes reverse the direction of current flow in the armature windings to turn the applied DC voltage into a rotational motion. A PMDC motor works by interacting its current-carrying armature windings with the magnetic field produced by the permanent magnets. A magnetic field is created as a current pass through the armature windings. This magnetic field interacts with the fixed magnetic field produced by the permanent magnets.

The Lorentz force, which is produced by this interaction, propels the rotor's rotation. PMDC motors have a number of benefits. High motor efficiency is achieved by the steady and powerful magnetic field provided by permanent magnets. The lack of field windings minimizes the

motor's complexity and upkeep requirements. PMDC motors are appropriate for applications where weight and space are constrained, such as in robotics, portable electronics, and automotive applications because of their small size and high power-to-weight ratio. PMDC motors are very simple to reverse and provide strong speed control. The applied voltage can be changed, or electronic speed control techniques can be used to change the motor's speed. This qualifies them for uses that call for precise speed control, such as industrial automation, conveyors, and machine tools. PMDC motors' reliance on permanent magnets to produce the magnetic field is one of their drawbacks, though.

The nature and properties of the permanent magnets determine the strength of the magnetic field. The performance of the motor may be impacted if the magnets gradually demagnetize or deteriorate. In addition, compared to other motor types, the cost of premium permanent magnets might be somewhat high. A permanent magnet DC motors are electric motors that produce the magnetic field using permanent magnets. They have benefits including great efficiency, small size, and effective speed control. Robotics, portable electronics, automotive systems, and industrial automation are just a few of the many applications that PMDC motors are employed in. However, how well they perform is based on how strong and long-lasting the permanent magnets are. Each kind of DC motor has distinctive qualities and is appropriate for particular applications. The needed torque, required speed control, efficiency, size restrictions, and cost considerations are only a few examples of the variables that affect the choice of DC motor type.

**Applications of DC Motor:** Due to their adaptability, dependability, and capacity for fine control, DC motors are used in a variety of businesses and sectors. Here are a few notable uses for DC motors:

- a. Industrial Automation:** Systems for industrial automation frequently use DC motors. Conveyor belts, assembly lines, robotics, packaging equipment, and CNC machines are just a few of the machines and equipment they power. They are perfect for these applications because they can deliver exact speed control and torque, enabling the efficient and precise movement of materials and components.
- b. Electric Vehicles:** The development of electric vehicles (EVs) has been greatly aided by the use of DC motors. In EVs, they are utilized to drive the wheels, supplying the propulsion system with the torque and power required. Traditional DC motors have been extensively employed in early electric car models because to their simplicity and affordability, even if newer technologies like brushless DC motors are gaining ground in this industry.
- c. Aerospace and Defense:** Defense and aerospace industries both use DC motors in a number of applications. Actuators in aircraft that operate flaps, landing gear, and control surfaces use them. DC motors are also used to power missile launchers, satellite positioning systems, guidance systems, and other essential defense and aerospace components. They are appropriate for these demanding applications due to their small size, strong torque, and consistent performance.
- d. Home Appliances:** A range of household gadgets employ DC motors to operate efficiently and consistently. They are utilized in a variety of appliances, including fans, vacuum cleaners, washing machines, and dishwashers. DC motors improve the performance and usefulness of these products by providing advantages including energy efficiency, quiet operation, and variable speed control.



- e. **Renewable Energy Systems:** DC motors are important components of systems that use renewable energy. To transform wind or solar energy into electrical energy, they are utilized in wind turbines and solar tracking systems. To maximize the capture of renewable energy sources, DC motors are used to change the position and angle of solar panels or wind turbine blades.
- f. **Medical Equipment:** A variety of medical gadgets and equipment use DC motors. Infusion pumps, blood analyzers, ventilators, dental drills, and surgical robots all contain them. DC motors ensure the accurate and secure operation of medical equipment through precise control and dependable performance.
- g. **Automotive Industry:** While brushless DC motors are becoming more popular in the industry because they are better suited for electric vehicles, conventional DC motors are still used in several automotive systems. They are employed in auto mechanisms such as power windows, power seats, and windshield wiper systems because they are straightforward and reasonably priced.
- h. **Robotics:** For joint actuation, locomotion, and manipulation activities in robotics, DC motors are frequently utilized. They give robots the torque and control they need to accomplish precise and difficult tasks in the sectors of industry, research, and medicine.
- i. **Marine Applications:** DC motors are used in the marine sector to power steering systems, propulsion systems, winches, and other machinery aboard boats and ships. They are suitable for marine applications due to their durable construction and capacity to function under challenging conditions.

These are just a handful of the numerous uses for DC motors. Because of their adaptability and dependability, they are a crucial part of many industries and enable accurate and effective management of mechanical systems. DC motors are expected to find even more unique and varied applications in the future as technology develops.

**Advantages of DC Motor:** DC motors are favored in many applications due to their numerous benefits. These are some of the main benefits of DC motors:

1. **Strong Starting Torque:** DC motors have a strong starting torque that enables them to start a load effectively despite its inertia. This trait is especially useful when driving big loads or in applications that need frequent starting and stopping.
2. **Speed Control:** DC motors provide exceptional capabilities for speed control. A DC motor's speed can be easily changed over a large range by altering the voltage delivered to the motor or by applying electronic control techniques. In applications where maintaining a particular speed is essential, such conveyor systems or robotics, this exact speed control is essential.
3. **Efficiency:** High efficiency is a well-known characteristic of DC motors. They can reduce energy waste by converting a sizable amount of electrical energy into mechanical energy. In many applications, this efficiency helps to lower power consumption and operational expenses.
4. **Simple and Robust Design:** DC motors have a straightforward design that makes them simple to comprehend, produce, and maintain. A rotor, stator, and commutator in brushed

DC motors are some of their fundamental parts. Their durable design guarantees dependable performance and longevity in a variety of settings.

5. **Compact Size:** Because DC motors are available in small sizes, they are suited for applications where there is a lack of space. Their compact size makes it simple to integrate them into various systems without taking up much room.
6. **Cost-Effectiveness:** Compared to some other motor types, DC motors are typically less expensive. They are easy to manufacture and maintain because of their simplicity design and use of basic control mechanisms. Because of their affordability, DC motors are a common choice across numerous industries.
7. **Instantaneous Reaction:** When the input voltage or control signals change, DC motors react instantly. They are suited for applications that call for swift and accurate motions because of their ability to start, halt, and change direction swiftly.
8. **Reliability:** DC motors are renowned for their dependability and lengthy service lives. They can run reliably for a long time if maintained and cared for properly. Their overall reliability is a result of their simple design and lack of intricate control mechanisms.
9. **Wide Variety of Sizes and Types:** To accommodate various applications, DC motors are offered in a wide variety of sizes, power ratings, and types. There is a DC motor available to satisfy individual requirements, whether it is a small motor for a handheld device or a huge motor for industrial gear.
10. **Compatibility with Power Sources:** DC motors are compatible with a range of power sources, including batteries, rectified AC power, and DC power supply. They can be employed in a variety of applications and sectors because to their adaptability.

In general, DC motors are well suited for a wide range of applications across industries, including industrial automation, electric cars, home appliances, and robots. These benefits include high starting torque, speed control, efficiency, simplicity, and reliability.

## CONCLUSION

DC motors have played a significant role in the advancement of contemporary technology and are used in a wide range of sectors. They are appropriate for a variety of applications thanks to their capacity to offer precise control, strong torque, and efficient operation. DC motors are essential for providing the appropriate motion and functionality in robotics and electric vehicles alike. In many situations, their simplicity, dependability, and affordability make them the best option. To satisfy the expanding demands of many industries, it is crucial to continue research and innovation in the field of DC motors. This is because new motor technologies, including brushless DC motors, are emerging. In general, DC motors continue to be a crucial part of many applications and are likely to continue influencing technological development in the future.

## REFERENCES:

- [1] L. I. Santos, R. M. Palhares, M. F. S. V. D'Angelo, J. B. Mendes, R. R. Veloso, and P. Y. Ekel, "A New Scheme for Fault Detection and Classification Applied to DC Motor," *TEMA (São Carlos)*, 2018, doi: 10.5540/tema.2018.019.02.327.
- [2] T. Zimnickas, J. Vanagas, K. Dambrauskas, A. Kalvaitis, and M. Ažubalis, "Application

- of advanced vibration monitoring systems and long short-term memory networks for brushless DC motor stator fault monitoring and classification,” *Energies*, 2020, doi: 10.3390/en13040820.
- [3] D. Ravi, B. M. Reddy, S. L. Shimi, and P. Samuel, “Bidirectional dc to dc converters: An overview of various topologies, switching schemes and control techniques,” *Int. J. Eng. Technol.*, 2018, doi: 10.14419/ijet.v7i4.5.20107.
- [4] S. Singh, “DC motor drives,” in *Modeling, Simulation and Control of Electrical Drives*, 2019. doi: 10.1049/pbce118e\_ch4.
- [5] M. S. Bhaskar *et al.*, “Survey of DC-DC non-isolated topologies for unidirectional power flow in fuel cell vehicles,” *IEEE Access*, 2020, doi: 10.1109/ACCESS.2020.3027041.
- [6] L. Lu and W. Wang, “Fault diagnosis of permanent magnet dc motors based on multi-segment feature extraction,” *Sensors*, 2021, doi: 10.3390/s21227505.
- [7] D. Kumar, R. K. Nema, and S. Gupta, “A comparative review on power conversion topologies and energy storage system for electric vehicles,” *International Journal of Energy Research*. 2020. doi: 10.1002/er.5353.
- [8] Y. J. Yang, E. J. Jeon, J. S. Kim, and C. K. Chung, “Characterization of kinesthetic motor imagery compared with visual motor imageries,” *Sci. Rep.*, 2021, doi: 10.1038/s41598-021-82241-0.
- [9] L. L. Li, J. Q. Liu, W. B. Zhao, and L. Dong, “Fault diagnosis of high-speed brushless permanent-magnet dc motor based on support vector machine optimized by modified grey wolf optimization algorithm,” *Symmetry (Basel)*., 2021, doi: 10.3390/sym13020163.
- [10] R. S. Araujo, C. R. Silva, S. P. N. Netto, E. Morya, and F. L. Brasil, “Development of a Low-Cost EEG-Controlled Hand Exoskeleton 3D Printed on Textiles,” *Front. Neurosci.*, 2021, doi: 10.3389/fnins.2021.661569.

## SYNCHRONOUS MACHINE:THEORY, MODELING, AND APPLICATIONS

**Mr. Sreekanth Kondreddy\***

\*Assistant Professor,  
Department of Electrical And Electronics Engineering,  
Presidency University, Bangalore, INDIA  
Email Id-ksreekanthreddy@presidencyuniversity.in

### ABSTRACT:

*Because of their low rotational synchronous speeds that generate voltage at grid frequency, synchronous generators are widely employed for variable speed wind turbine applications. Synchronous generators may be an effective choice for variable speed wind turbine operation. Consider the stator windings coupled to a three-phase alternating-current source to understand the functioning of a synchronous motor. The result of the stator current is to create a magnetic field that rotates at 120 f/p rotations per minute for f hertz and p poles. Important electrical devices known as synchronous machines are frequently employed in electric propulsion systems, industrial applications, and power generation. The operational concepts, design, and applications of synchronous machines are highlighted in this chapter.*

**KEYWORDS:** *Synchronous Machine's Applications, Synchronous Machines, Synchronous Generator, Synchronous Motors, Special-Purpose Synchronous Machines.*

### INTRODUCTION

An electrical device that transforms mechanical energy into electrical energy is a synchronous machine, commonly referred to as a synchronous generator or alternator. It functions according to the electromagnetic induction principle, in which the machine's revolving magnetic field causes the stator windings to produce an alternating current (AC). We shall go over a synchronous machine's construction, operation, and applications in this essay. A synchronous machine's operation is based on electromagnetic induction's Faraday's law. It is made up of a revolving component known as the rotor and a stationary component called the stator. The three-phase winding that makes up the stator is typically inserted into slots on the inner edges of the stator core. The stator windings conduct an AC current, which results in the creation of a revolving magnetic field. The rotor is a cylindrical device set on a shaft constructed of a laminated iron core. A source of direct current (DC) is used to excite the field windings that are present. The revolving magnetic field of the stator interacts with the magnetic field produced by the rotor windings. Synchronous functioning is achieved by the rotor's attempt to align itself with the stator's magnetic field. The rotor must rotate at the same rate as the revolving magnetic field of the stator, which is dictated by the frequency of the AC supply, in order to ensure synchronization. The following formula determines the synchronous machine's speed[1]–[3]:

Speed (in RPM) = (120 x Frequency) / Number of Poles

The synchronous machine has a number of crucial traits. First off, it runs at a constant synchronous speed, which makes it perfect for applications that need exact synchronization and a

stable pace, like power generation in power plants. Second, it can function as a motor or a generator. The rotor functions as a motor, transforming electrical energy into mechanical energy when mechanical power is applied to it. On the other hand, the stator functions as a generator when electrical power is applied, transforming mechanical energy into electrical energy. A sturdy frame to hold the stator and rotor as well as bearings to let the rotor shaft rotate are all parts of the building of a synchronous machine. To reduce eddy current losses, the stator core is constructed of silicon steel that has been laminated. Slots in the rotor winding isolate the winding from the rotor core.

DC power is often provided to the field windings via slip rings or brushless excitation devices. There are many industries that use synchronous machinery. They serve as generators in power plants, transforming mechanical energy from turbines into electrical energy. They offer the grid with a dependable and coordinated power supply. Synchronous motors are employed in industrial settings where precise control of speed and torque is necessary, such as in compressors, pumps, and high-torque applications. They are also utilized in synchronous condensers for voltage stability and power factor correction. A synchronous machine, to sum up, is a flexible electrical device that changes mechanical energy into electrical energy and vice versa. A spinning magnetic field creates AC current in the stator windings according to the electromagnetic induction theory that underlies its operation. The design consists of a stator and rotor, with DC field windings driving the rotor. Power generating, industrial applications, and other industries that need accurate synchronization and torque control frequently use synchronous machines.

**Historical background of Synchronous Machine:** The synchronous machine's origins can be traced to the late 19th century, when electrical engineering was just getting started. Here is a quick rundown of the significant turning points and contributions that resulted in the creation of synchronous machines:

- a. **Early Electric Generators:** In the early 1800s, scientists like Joseph Henry and Michael Faraday made important strides in our understanding of electromagnetic induction, which served as the basis for the development of electric generators. These early generators produced electricity using stationary coils and a spinning magnet, or armature.
- b. **Direct Current (DC) Machines:** The first useful DC generators and motors were created in the 1870s by eminent innovators including Thomas Edison and Zénobe Gramme. These devices converted mechanical energy into electrical energy and vice versa using commutators and brushes. During this time, DC machines saw widespread adoption for a variety of applications.
- c. **Alternating Current (AC) is first introduced:** The late 19th century saw the emergence of AC power transmission, supported by innovators like Nikola Tesla and George Westinghouse. For long-distance transmission, AC power was preferable over DC power because it could be readily stepped up or down using transformers. Due of this, AC generators or alternators were required.
- d. **Synchronous Machines:** The polyphase system, created in the late 1880s by engineers like Galileo Ferraris and Mikhail Dolivo-Dobrovolsky, revolutionized the production and distribution of AC power. They understood that effective power generation and transmission could be achieved by utilizing synchronous machines and three-phase AC systems.



- e. **Invention of Synchronous Generators:** Synchronous generators were initially created independently in 1887 by Charles F. Scott and Oliver B. Shallenberger. A synchronous generator is also referred to as an alternator. Synchronous generators used an electromagnet's revolving magnetic field to create electricity in stationary armature windings. Compared to their predecessors, these generators were more efficient and reliable.
- f. **Design and technological improvements:** Synchronous machines have undergone considerable design and technological advancements over time. The discovery of superior insulating materials, the advent of brushless excitation systems, and improvements in solid-state electronics for control and monitoring were among the notable contributions.
- g. **Industrial Applications:** The production of electricity by synchronous machinery is widely used in power plants. Synchronous generators were widely utilized in large hydroelectric projects, thermal power plants, and later nuclear power plants. They provide a consistent and coordinated power supply to the expanding electrical grids around the world.
- h. **Motor Applications:** Synchronous machines were used to create electricity, but they were also used to create synchronous motors. They were excellent for a variety of industrial applications, including compressors, pumps, and heavy machinery, due to their ability to run at a consistent pace and deliver tremendous torque.
- i. **Current Developments:** Synchronous machines are still developing nowadays. Advanced materials, better cooling systems, digital control systems, and increased efficiency are all features of contemporary designs. The development of specialized synchronous generators and motors to capture clean energy has also resulted from the integration of renewable energy sources like wind turbines and solar power systems.

In summary, the history of synchronous machines ranges from the earliest electromagnetic induction experiments to the development of useful synchronous generators and motors. The contemporary electrical infrastructure we rely on today was shaped by these machines, which were crucial in the development of electrical power generation, transmission, and many industrial applications.

## DISCUSSION

**Construction of Synchronous Machine:** A synchronous machine is built with a number of essential parts that operate together to transform mechanical energy into electrical energy or the opposite. Here is a description of how a synchronous machine is built:

1. **Stator:** The stator, which makes up the exterior structure of the synchronous machine, is its stationary component. To reduce eddy current losses, it has a stator core constructed of laminated silicon steel. The stator core supports the stator windings and acts as a conduit for the magnetic flux. Three-phase windings called stator windings are frequently arranged in slots on the inner side of the stator core. When the winding arrangement receives three-phase AC electricity, a spinning magnetic field is produced.
2. **Rotor:** Mounted on a shaft, the rotor is the component of the synchronous machine that rotates. To minimize eddy current losses, it has a laminated silicon steel rotor core. The rotor core has slots that can hold the rotor windings and is shaped like a cylinder. The field windings on the rotor, which are commonly activated by a DC current source, are known as

the field windings. Synchronous functioning is achieved when the revolving magnetic field of the stator interacts with the magnetic field produced by the field windings.

3. **Bearings:** The rotor shaft of the synchronous machine is supported and allowed to rotate by bearings. Depending on the size and usage of the machine, several bearing types, such as ball bearings or roller bearings, are utilized. The bearings minimize friction losses and guarantee the rotor rotates smoothly.
4. **Excitation System:** The excitation system provides the rotor windings with the appropriate DC current. Older versions used slip rings and brushes to supply DC current, while newer synchronous machines frequently use brushless excitation systems. Brushless excitation systems offer a more dependable and upkeep-free alternative by doing away with the requirement for brushes.
5. **Frame and Housing:** A strong frame that offers structural support and security houses the synchronous machine. Steel is frequently used for the frame, which is constructed to withstand the mechanical and electromagnetic stresses encountered during operation. The machine is covered by a housing or enclosure to increase protection against the environment and to assure operator security.
6. **Cooling System:** In order to retain peak performance, synchronous machines must be cooled down after use. Depending on the machine's rating and use, different cooling techniques are used, including air cooling, hydrogen cooling, and water cooling. Fans, radiators, heat exchangers, or direct cooling techniques are frequently used in cooling systems to control the machine's temperature.
7. **Terminal Box:** The stator windings are connected to outside electrical circuits at the terminal box. It has terminals or bus bars that enable the equipment to be connected to the load or electrical system.

A synchronous machine is built using a sophisticated process that calls for accurate design and manufacturing methods in order to guarantee efficient and dependable performance. Each component is essential to creating and managing the magnetic fields required for synchronous operation and the conversion of electrical energy.

**Types of Synchronous Machines:** Synchronous machines come in a variety of varieties, each with a distinct design and use. The various synchronous machine types, such as synchronous motors, synchronous generators, and special-purpose synchronous machines, will be discussed in this essay.

**1.Synchronous Generators:** Synchronous generators, sometimes referred to as synchronous alternators, are mostly used to transform mechanical energy into electrical energy. They are frequently used in hydroelectric facilities, power plants, and other sizable electricity producing systems. On the basis of the electromagnetic induction principle, synchronous generators produce an alternating current (AC) in the stator windings[4]–[6].

- a. **Salient Pole Synchronous Generators:** Salient pole synchronous generators have rotors that resemble salient poles in shape, with projecting poles. They are frequently employed in applications like hydroelectric power plants where low speed and great power output are necessary. The salient pole design offers superior stability during abrupt load fluctuations

and facilitates simple field winding excitation. These generators can also be used in situations when a lot of poles are needed.

- b. Cylindrical Rotor Synchronous Generators:** A smooth cylindrical shape characterizes the rotor of cylindrical rotor synchronous generators. On the rotor's surface, slots are used to mount the field winding. In thermal power plants, gas turbine power plants, and other settings where high speed and moderate power output are needed, these generators are frequently utilized. When compared to salient pole generators, the cylindrical rotor design offers a superior power-to-weight ratio and enables effective cooling.

**2.Synchronous Motors:** Electric motors that use the synchronous operation concept, in which the rotor rotates at the same rate as the spinning magnetic field generated by the stator, are known as synchronous motors. Applications for them can be found throughout a number of sectors, including manufacturing, transportation, and energy conversion systems.

- a. Non-Excited (Hysteresis) Synchronous Motors:** Non-excited synchronous motors, commonly referred to as hysteresis motors, are unique varieties of synchronous motors that don't need an additional excitation device. They make use of a high hysteresis, low coercivity magnetic material for their hysteresis rotor. The hysteresis rotor rotates at the same rate as the stator field when subjected to a rotating magnetic field. These motors are frequently employed in devices like clocks, record players, and medical equipment that need strong torque and consistent speed.
- b. Permanent Magnet Synchronous Motors (PMSMs):** The magnetic field is produced by permanent magnets on the rotor in permanent magnet synchronous motors. They are ideal for a variety of applications, including robotics, electric cars, and industrial automation, because to their high efficiency, high power density, and accurate speed control. Due to the lack of rotor windings and their corresponding losses, PMSMs have a small footprint and excellent dynamic responsiveness.
- c. Brushless Excitation Synchronous Motors:** Also known as brushless motors, brushless excitation synchronous motors use a different excitation mechanism to deliver DC current to the rotor windings. Compared to motors with slip rings and brushes, these motors are more dependable and require less maintenance. Applications like computer disk drives, robotics, and aerospace systems all make extensive use of brushless motors because they offer high-speed operation, precision control, and low maintenance requirements.

**3.Special-Purpose Synchronous Machines:** Synchronous motors and generators are not the only kind of synchronous machines available; a number of other synchronous machines with special functions are also available.

- a. Synchronous Condensers:** Synchronous condensers are synchronous equipment used in electrical power systems to stabilize voltage and rectify power factor. They don't require a mechanical load to function, and their main purpose is to balance the reactive power on the grid. In order to keep the desired power factor and maintain the voltage levels, synchronous condensers can generate or absorb reactive power.
- b. Synchronous Reluctance Motors:** Synchronous reluctance motors, also referred to as switched reluctance motors, use the idea of reluctance torque to produce motion. These motors have stator windings and a rotor with prominent poles. The rotor aligns with the

stator's magnetic field when the stator currents are controlled, producing torque effectively. Because of their high efficiency, dependability, and affordability, synchronous reluctance motors are ideal for use in industrial machines, HVAC systems, and electric cars.

- c. Doubly-Fed Induction Generators (DFIG):** Doubly-fed induction generators (DFIG) are synchronous machines that are employed in wind turbines and other renewable energy systems. They have a wound rotor with independent excitation, which is connected to a slip ring assembly for power transfer. The variable speed functioning of DFIGs enables effective grid integration and electricity generation. When compared to fixed-speed induction generators, they have benefitted such greater power management, lower mechanical stress, and improved grid stability.

There are many different types of synchronous machines, each of which is created to meet a particular need for output power, speed, control, and efficiency. While synchronous motors are used to transform electrical energy into mechanical energy, synchronous generators are used to transform mechanical energy into electrical energy. Applications for specialized synchronous machines include power systems, industry, and renewable energy systems. Examples include synchronous condensers, reluctance motors, and doubly-fed induction generators. The wide variety of synchronous machines enables accurate and effective electrical energy conversion in a variety of engineering and technological disciplines.

**Excitation system of Synchronous Machine:**By delivering the necessary direct current (DC) stimulation to the rotor windings, excitation systems play a critical part in the operation of synchronous machines. The rotor's magnetic field strength is managed by the excitation system, allowing the synchronous machine to run at the required voltage and power factor. Synchronous machines use a variety of excitation systems, including the following:

- a. DC Excitation Systems:** The most classic and typical excitation system utilized in synchronous machines is the DC excitation system. They entail using a different DC power source to deliver excitation current to the rotor windings. A rectifier coupled to an external DC source, such as a battery or an alternator powered by a tiny primary mover, can provide the DC power. The synchronous machine operates properly thanks to the stable and dependable stimulation provided by the DC excitation system.
- b. Brushless Excitation Systems:** Due to their benefits in terms of decreased maintenance, increased dependability, and superior control, brushless excitation systems have become more and more common. The brushes and slide rings used in conventional DC excitation systems are not necessary with these systems. The AC output of a three-phase exciter is instead converted to DC current by a revolving rectifier assembly installed on the rotor shaft in brushless excitation systems. The rotor windings are subsequently given the DC current. Brushless excitation systems are appropriate for situations that call for precise voltage and power factor management because they provide greater voltage regulation and control capabilities.
- c. Static Excitation Systems:** To control the excitation current, static excitation systems also referred to as digital excitation systems use solid-state components like thyristors or insulated gate bipolar transistors (IGBTs). Compared to conventional DC excitation systems, these systems offer more sophisticated control features and quicker response times. Numerous control features, including as automatic voltage regulation, power factor management, and

reactive power compensation, can be offered by static excitation systems. Large power plants and synchronous equipment that are connected to the grid frequently employ them.

- d. Permanent Magnet Excitation Systems:** Systems that use permanent magnets incorporated in the rotor to generate the excitation current are known as permanent magnet excitation systems. These systems do not require field windings or external DC sources. The rotor windings are guaranteed to self-excite because the permanent magnets produce a steady magnetic field. Systems for permanent magnet excitation are straightforward, highly effective, and operate without maintenance. They are frequently employed in small-scale synchronous machinery, like tiny motors or generators. The size of the synchronous machine, the necessary control features, the desired efficiency, and the particular application are only a few of the variables that influence the excitation system selection. The choice of excitation system relies on the required performance and operating circumstances, each of which has advantages and limitations.

Excitation systems are crucial parts of synchronous machines because they supply the rotor windings with the required excitation current. Synchronous machines frequently employ DC excitation systems, brushless excitation systems, static excitation systems, and permanent magnet excitation systems, each of which has certain advantages in terms of control, dependability, and efficiency. The synchronous machine's unique requirements and the application it supports determine the excitation system to use.

**Power Factor:** Power factor is a crucial metric for determining how effectively electrical systems use power. In an AC circuit, it shows the proportion of actual power (active power) to apparent power. The power factor ranges from 0 to 1, with 1 being a perfect or unity power factor. Real power (P) and reactive power (Q) are the two parts of power in an AC circuit. Reactive power is the power required to create and maintain magnetic fields in inductive or capacitive loads, whereas real power is the actual power that does practical work, such as running motors or producing heat.

The cosine of the angle ( $\theta$ ) between the voltage and current waveforms in an AC circuit is used to determine the power factor (PF):

$$PF = \cos(\theta) = P / S$$

S is the apparent power, which is determined by adding the vectors of reactive power (Q) and actual power (P):

$$S = \sqrt{P^2 + Q^2}$$

For effective power use, it is preferable for the real power and perceived power to be in phase, which is indicated by a power factor of 1 (unity power factor). Reactive power is wasted when the voltage and current waveforms have a time lag, which is shown by a power factor of less than 1 (lagging power factor). When the current waveform precedes the voltage waveform, the power factor is greater than 1 (leading power factor)[7]–[9].

**Efficiency:** Efficiency refers to a system's or device's ability to convert input power into usable output power. Efficiency is frequently referred to as electrical efficiency when referring to electrical systems, and it is computed as the ratio of output power to input power. The efficiency of a synchronous machine, such as a motor or generator, is influenced by a number of variables,



including magnetization losses, mechanical losses, and electrical losses. Copper losses from resistance occur in the stator and rotor windings as well as core losses from eddy currents and hysteresis in the magnetic core. These are examples of electrical losses. Friction losses, windage losses, and bearing losses are examples of mechanical losses. Due to the energy needed to magnetize the rotor field winding, magnetization losses happen. The formula for a synchronous machine's overall efficiency ( $\eta$ ) is as follows:

$$\eta = (\text{Output Power} / \text{Input Power}) \times 100\%$$

Depending on the load circumstances and the synchronous machine's operating point, efficiency can change. Synchronous machines often operate more efficiently at near- or rated loads because there, losses are kept to a minimum. The efficiency may drop under lighter loads or overload circumstances because of higher losses. By reducing the reactive power component and, consequently, the overall perceived power and the related losses, improving power factor can improve the efficiency of electrical systems. System efficiency can be raised by using power factor adjustment techniques, such as the use of capacitors or synchronous condensers. Efficiency measures how well a system or device turns input power into usable output power, whereas power factor measures how well power is used in electrical systems. Optimizing power use and reducing energy losses in electrical systems requires regulating power factor and efficiency.

**Significance of Synchronous Machine in the field of Electrical Engineering:** Electrical engineering places a lot of emphasis on power factor and efficiency. They are noteworthy for the following main reasons:

- a. **Power System Operation and Stability:** Power factor has an impact on these two factors. Increased reactive power flow, which results in voltage dips, increased line losses, and decreased system efficiency, are all effects of a low power factor (lagging). Additionally, it may lead to poor voltage regulation, voltage flicker, and a reduction in power transfer efficiency. The voltage profile and stability of the power system can be improved by increasing power factor.
- b. **Energy Efficiency and Cost Savings:** Increasing power factor strongly correlates with increased energy efficiency and cost savings. Higher reactive power demand caused by low power factor necessitates larger transformers, more generation capacity, and higher transmission and distribution losses. The apparent power demand is decreased by increasing power factor, which lowers electricity costs, increases energy efficiency, and optimizes resource utilization.
- c. **Performance of Electrical Equipment:** Synchronous equipment, transformers, cables, and other electrical devices are made to function effectively at particular power factors. Low power factors can shorten equipment longevity, increase equipment overheating, and diminish efficiency. Electrical equipment performs best and lasts the longest when the power factor is kept high.
- d. **Enhancing Power Quality:** Power factor correction is essential for raising power quality. Harmonic distortions, voltage drops, and voltage swings can all be caused by a poor power factor. These problems may have an impact on delicate electrical and electronic equipment, leading to malfunctions, a shorter lifespan, and more frequent maintenance needs. Power

quality is enhanced by maintaining a high-power factor, resulting in steady and dependable equipment performance.

- e. **Environmental Impact:** Low power factor causes inefficient power utilization, which increases losses during power generation, transmission, and distribution. Increased carbon emissions and environmental damage are a result of these losses. The demand for electrical power is decreased, resulting in lower greenhouse gas emissions and positive effects on the environment. This is accomplished through increasing power factor and overall system efficiency.
- f. **Utility regulations compliance:** Customers with low power factors are frequently subject to fines or additional fees from the utilities. By maintaining a high-power factor, one can abide by utility laws and stay out of trouble. In order to promote energy-efficient behaviors, some utilities also offer incentives or discounts to consumers who actively raise power factor.

The fields of electrical engineering are greatly affected by power factor and efficiency. They have an impact on utility regulatory compliance, equipment performance, equipment efficiency, power quality, and environmental impact. To ensure reliable and sustainable functioning of electrical systems while reducing energy losses and environmental effect, electrical engineers work to optimize power factor and efficiency.

**Applications of Synchronous Machine:** Numerous industries and sectors use synchronous machines in various ways. The following are some of the main uses for synchronous machines:

**Power Generation:** Alternators, usually referred to as synchronous generators, are widely utilized in power generation systems. The mechanical energy is transformed into electrical energy by them. Power facilities, such as thermal power plants, hydroelectric power plants, and nuclear power plants, use synchronous generators to create electricity on a massive scale. They contribute to the overall energy supply by generating power in a steady and reliable manner.

**Grid Synchronization and Stability:** Synchronous generators are essential for maintaining the synchronization and stability of the grid. To make sure that the electrical power generated is in phase and frequency with the grid, they are synchronized with it. Synchronous generators sustain reactive power, regulate voltage, and promote grid stability under both typical and unusual operating situations. They aid in keeping the voltage and power factor within reasonable bounds.

**Motor Operation:** Synchronous motors are employed in many industrial applications where accurate speed control and strong torque capabilities are necessary. They work in sectors including manufacturing, mining, petroleum, and chemicals. Applications that require constant speed operation, such pumps, compressors, conveyors, and machine tools, frequently use synchronous motors.

**Renewable Energy Systems:** Systems for producing renewable energy use synchronous machinery, particularly synchronous generators. Synchronous generators are used in wind turbines to transform the wind's rotational energy into electrical energy. They offer grid synchronization and management for effective energy production. In hydroelectric power plants, synchronous generators are also employed to transform the mechanical energy of moving water into electrical energy[10].

**Excitation Systems:** Excitation systems employ synchronous machines directly. Electrical power systems use synchronous condensers for voltage stabilization and power factor adjustment since they are essentially synchronous machines working without a mechanical load. To control the power factor and maintain voltage levels, they generate or absorb reactive power.

**Applications that Demand High accuracy:** Synchronous machines are used in sectors that demand high accuracy and control. They are employed in robotics and automation systems, for instance, where exact motion control and synchronization are crucial. Synchronous motors are appropriate for uses like CNC machines, robotics, and printing presses because they provide precise speed control and positioning capabilities.

**Research and Testing:** Synchronous machines are frequently used in research labs and testing facilities, which is research and testing. Researchers and engineers can study and examine numerous facets of electrical machines, power systems, and control systems using them as test equipment for a variety of electrical and mechanical studies. A dependable environment for performing experiments and verifying theoretical ideas is provided by synchronous machines.

Synchronous machines have a wide range of uses, including power production, grid synchronization, motor operation, renewable energy systems, excitation systems, high-precision applications, research, and testing. They are valuable assets in a variety of industries and sectors due to their adaptability, dependability, and controllability, which helps ensure the stable and effective operation of electrical systems.

## CONCLUSION

In many fields, including power generation and industrial uses, synchronous machines are essential. The revolving magnetic fields of the stator and rotor must be in synchronism in order for these machines to work. While synchronous motors offer accurate speed control in industrial applications, synchronous generators are frequently utilized to convert mechanical energy into electrical power. Through effective excitation control, synchronous machines' efficiency and power factor can be maximized. Electrical engineers and technicians working in power systems and related industries must comprehend the basic ideas behind synchronous machines and how they are used.

## REFERENCES:

- [1] S. Eriksson, "Permanent magnet synchronous machines," *Energies*. 2019. doi: 10.3390/en12142830.
- [2] S. D'Arco, J. A. Suul, and O. B. Fosso, "A Virtual Synchronous Machine implementation for distributed control of power converters in SmartGrids," *Electr. Power Syst. Res.*, 2015, doi: 10.1016/j.epsr.2015.01.001.
- [3] Z. Q. Zhu, D. Liang, and K. Liu, "Online Parameter Estimation for Permanent Magnet Synchronous Machines: An Overview," *IEEE Access*. 2021. doi: 10.1109/ACCESS.2021.3072959.
- [4] M. Ashabani and J. Jung, "Synchronous voltage controllers: Voltage-based emulation of synchronous machines for the integration of renewable energy sources," *IEEE Access*, 2020, doi: 10.1109/ACCESS.2020.2976892.

- [5] O. Mo, S. Darco, and J. A. Suul, "Evaluation of Virtual Synchronous Machines with Dynamic or Quasi-Stationary Machine Models," *IEEE Trans. Ind. Electron.*, 2017, doi: 10.1109/TIE.2016.2638810.
- [6] S. D'Arco and J. A. Suul, "Equivalence of virtual synchronous machines and frequency-droops for converter-based Microgrids," *IEEE Trans. Smart Grid*, 2014, doi: 10.1109/TSG.2013.2288000.
- [7] B. Barac, M. Krpan, T. Capuder, and I. Kuzle, "Modeling and Initialization of a Virtual Synchronous Machine for Power System Fundamental Frequency Simulations," *IEEE Access*, 2021, doi: 10.1109/ACCESS.2021.3130375.
- [8] A. Tayyebi, D. Grob, A. Anta, F. Kupzog, and F. Dorfler, "Frequency Stability of Synchronous Machines and Grid-Forming Power Converters," *IEEE J. Emerg. Sel. Top. Power Electron.*, 2020, doi: 10.1109/JESTPE.2020.2966524.
- [9] K. Sebaa, Y. Zhou, Y. Li, A. Gelen, and H. Nouri, "Low-frequency Oscillation Damping Control for Large-scale Power System with Simplified Virtual Synchronous Machine," *J. Mod. Power Syst. Clean Energy*, 2021, doi: 10.35833/MPCE.2020.000340.
- [10] M. Ebrahimi, S. A. Khajehoddin, and M. Karimi-Ghartemani, "An Improved Damping Method for Virtual Synchronous Machines," *IEEE Trans. Sustain. Energy*, 2019, doi: 10.1109/TSTE.2019.2902033.

## SYNCHRONOUS GENERATOR AND ALTERNATOR: A BRIEF OVERVIEW

**Mr. Bishakh Paul\***

\*Assistant Professor,  
Department of Electrical And Electronics Engineering,  
Presidency University, Bangalore, India,  
Email Id-bishakhpaul@presidencyuniversity.in

### ABSTRACT:

*Alternators and synchronous generators are essential parts of electrical power systems that produce alternating current (AC). These devices are widely employed in many different applications, including portable generators and power plants. An overview of synchronous generators and alternators' functions and main distinctions is given in this chapter. It emphasizes how crucial these electrical devices are for producing alternating current (AC) for a range of uses. Additionally, the chapter skims over several of their fundamental concepts and parts. Synchronous generator, alternator, AC generation, rotating magnetic field, excitation, and stator are some of the keywords related to this chapter.*

**KEYWORDS:** *Brushless Synchronous Generator, Self-Excited Synchronous Generator, Synchronous Generator, Synchronous Alternator, Synchronous Alternator Applications.*

### INTRODUCTION

Alternators and synchronous generators are essential parts of electrical power systems that produce alternating current (AC). These devices are widely employed in many different applications, including portable generators and power plants. We will examine the construction, functionality, and operating concepts of synchronous generators and alternators in this thorough introduction. We will also go over how they differ from one another, how they are used, and how important they are to electrical engineering[1]–[3].

**Synchronous Generator:** Alternators, commonly referred to as synchronous generators, are crucial components used to transform mechanical energy into electrical energy. They are essential to power generation systems because they provide electricity for homes, businesses, and a variety of other uses. We shall examine the fundamental concepts, design, and operation of synchronous generators in this post. Let's first comprehend the fundamental idea that drives a synchronous generator's operation. The electromagnetic induction theory, which Michael Faraday first identified in the early 19th century, underlies how these generators work. According to Faraday's law, an electromotive force (EMF) is induced in a conductor when it is exposed to a fluctuating magnetic field. This idea is the basis for synchronous generators, which produce electricity. A synchronous generator is built from a number of essential parts. The rotor and the stator are the two major components. The generator's revolving component, known as the rotor, is normally constructed of a solid iron core with slots for insulated copper wires that act as electromagnets. The stator, which surrounds the rotor and is stationary, is made up of a laminated



iron core with slots for the stator windings. A three-phase system is created by connecting these windings together.

The interaction between the rotor and the stator is the foundation of a synchronous generator's operation. A magnetic field is produced by the rotor, often referred to as the field winding, when it is energized by a DC current. According to Faraday's law, this magnetic field causes a voltage to be induced in the stator windings. The desired electrical output is created when an AC current flows through the stator windings as a result of the induced voltage. Synchronous generators must run at a constant speed, referred to as the synchronous speed, in order to achieve synchronization with the power system. The electrical system's frequency and number of poles define the synchronous speed. A generator's speed is directly inversely correlated to the number of its poles, hence generators with more poles would run at slower speeds. Controlling the power factor is a crucial feature of synchronous generators. How well a generator transforms mechanical power into electrical power is determined by its power factor. The phase angle between the voltage and current waveforms has an impact on it. Synchronous generators can manage the power factor and raise the system's overall effectiveness by modifying the excitation current.

Synchronous generators are widely used in the production of electricity, especially in large-scale power plants. To transform the mechanical energy from these sources into electrical energy, these generators are frequently connected to steam turbines, hydro turbines, or gas turbines. Synchronous generators ensure a steady supply of electricity by supplying the necessary power to suit the needs of businesses, communities, and nations. Synchronous generators are also utilized in a number of specific applications. They are used in renewable energy systems where rotational motion is used to produce electricity, such as wind turbines and tidal power plants. Synchronous generators are also used as auxiliary power sources in diesel-electric trains and ships. Modern technologies and control methods have been created to improve the performance and efficacy of synchronous generators. Excitation systems, voltage regulators, and automatic synchronizing systems are some of these technologies. These developments make it possible for generators to adapt to variations in electrical demand, keep their operations steady, and deliver dependable electricity to the grid. Synchronous generators are essential tools for transforming mechanical energy into electrical energy, to sum up. These generators use the interaction between the rotor and stator to generate electricity using the principles of electromagnetic induction. They are essential to the production of power because they provide homes, businesses, and other uses with energy. Synchronous generators are constantly evolving, assuring the efficiency and dependability of power networks all over the world.

**Synchronous Alternator:** An electrical device that changes mechanical energy into electrical energy is a synchronous alternator, commonly referred to as a synchronous generator. Like other kinds of generators, it works on the electromagnetic induction principle. A generator that generates alternating current (AC) is explicitly referred to as a "alternator" in this context. A synchronous alternator is built similarly to a synchronous generator, and it operates on the same basic principles. A rotor and a stator make up its two primary parts. The alternator's revolving component is called the rotor, while the stator is stationary. A field winding inside the rotor is stimulated to produce a magnetic field by a direct current (DC). The stator is made up of stator windings coupled in a three-phase configuration. Through electromagnetic induction, the magnetic field produced by the field winding induces a voltage in the stator windings when the

rotor is rotating. Alternating current flows through the stator windings as a result of this voltage. The alternator's speed of rotation and number of poles affect the frequency and voltage of the electricity it produces. The primary distinction between a synchronous alternator and other generator types, such as asynchronous (induction) generators, is that a synchronous alternator's output frequency is governed by the rotor's rotational speed and the number of poles. It runs at a constant pace known as the synchronous speed, which is inversely related to the frequency of the electricity generated.

Because of this, synchronous alternators can be used in systems like power grids and large-scale power generation systems where a stable and consistent frequency is necessary. Compared to other generator types, synchronous alternators provide a number of benefits. Their capacity to manage the power factor is a key asset. The effectiveness of power transfer between the generator and the load is gauged by the power factor. Synchronous alternators can manage the power factor and raise the system's overall efficiency by modifying the excitation current sent to the field winding. Synchronous alternators also have the benefit of being able to run in parallel with other generators. Parallel connections between generators enable them to share the electrical load, resulting in a more dependable and effective power source. Synchronous alternators can be connected in parallel without generating disruptions or imbalances since they are made to synchronize their voltage, frequency, and phase with the current power supply.

In power production systems, ranging from small-scale applications to major power plants, synchronous alternators are widely utilized. In thermal power plants, hydroelectric power plants, and gas turbine power plants, they are frequently used. In these applications, the synchronous alternators are driven by mechanical energy from steam turbines, water turbines, or gas turbines, which generates electricity. Synchronous alternators are also utilized in numerous commercial and industrial situations, including renewable energy systems, backup power systems, and emergency power sources. To deliver dependable power during power outages or in remote locations without access to the main power grid, they might be linked with diesel engines or turbines. a synchronous alternator is an electrical device that uses electromagnetic induction to transform mechanical energy into electrical energy. It generates alternating current with a constant frequency and runs at a fixed speed known as the synchronous speed. Advantages of synchronous alternators include power factor control and the capacity to run in parallel with other generators. To deliver a dependable and effective electricity supply, they are frequently employed in power production systems, industrial applications, and renewable energy systems.

**Working principle of Synchronous Generator and Alternator:**Both synchronous generators and synchronous alternator's function using the electromagnetic induction principle, hence their operating principles are very similar. Let's investigate how these machines function. A synchronous generator, also called a synchronous alternator, uses the interaction of a spinning magnetic field and stationary conductors to transform mechanical energy into electrical energy. A rotor and a stator are the two major parts of the generator. A synchronous generator's revolving component, known as the rotor, typically has a solid iron core with holes for insulated copper wires. Field windings is a common name for these conductors. With the exception of brushless excitation systems, slip rings and brushes are normally used to connect the field windings to an external DC power supply. A magnetic field is produced in the rotor when the field windings are energized with direct current. On the other hand, the stator, which encloses the rotor, is the generator's fixed component.

The core is made of laminated iron and has spaces for the stator windings. The stator windings are connected to the load or electrical system and are normally organized in a three-phase design. The rotor revolves at a steady speed when it is powered by a prime mover, like a steam turbine or a gas engine. Through electromagnetic induction, the magnetic field produced by the field windings induces a voltage in the stator windings as the rotor rotates. A change in the magnetic field induces a voltage in a conductor, in accordance with Faraday's law of electromagnetic induction. Alternating current (AC) flows in the stator windings as a result of the induced voltage. The rotor's rotating speed and the generator's pole count both affect the frequency of the AC output. The rotor and stator's design and construction dictate how many poles the generator will have. The synchronous generator must be run at a speed that corresponds to the synchronous speed, which is inversely proportional to the frequency of the electrical system to which it is connected.

The generator won't be able to keep synchronization with the system and may encounter instability or failure if it deviates greatly from the synchronous speed. The excitation current supplied to the field windings of the synchronous generator can be changed to alter the output voltage and frequency. The rotor's magnetic field strength can be altered by adjusting the excitation current, which will also alter the output voltage and reactive power flow. Synchronous generators can manage the voltage and power factor of the electrical system to which they are attached. A synchronous generator's or alternator's operating mechanism entails creating a revolving magnetic field in the rotor through the field windings. Alternating current is produced as a result of the voltage that this magnetic field causes to appear in the stator windings. The generator may deliver a controlled output voltage and frequency by staying in sync with the electrical system and managing the excitation current.

## DISCUSSION

**Types of Synchronous Generator and Alternator:** The architecture, excitation techniques, and application requirements of synchronous generators and alternators determine the various varieties of these devices. Let's examine a few of the often employed types[4]–[6]:

**1. Salient Pole Synchronous Generator:** The rotor of a salient pole synchronous generator has prominent poles and concentrated windings. A greater air gap is provided by the salient poles, making cooling and maintenance simpler. Salient pole generators work well for low-speed applications and are frequently seen in hydroelectric power facilities. A clear pole A particular kind of synchronous generator known as a synchronous generator is distinguished by the design of its rotor. The rotor in this design has protruding poles that are bolted or otherwise connected to the rotor core, hence the term salient pole. These poles often feature concentrated windings and are composed of laminated steel. Numerous benefits come with the salient pole design, which is frequently employed in large-scale power generation applications. Its capacity to deliver a higher level of reactance is one of its main advantages. Reactance is a measurement of the resistance to alternating current flow induced by the generator's inductive and capacitive components. T

he generator can attain a larger reactance by having salient poles, which is advantageous for stability and voltage management. A solid rotor core with slots to accommodate the pole windings is a necessary component of the construction of a salient pole synchronous generator. Typically, copper conductors that have been varnished or covered with various insulating materials form the pole windings. Electromagnets are created by connecting these windings in

sequence. A primary mover, such as a steam turbine or a hydraulic turbine, moves the rotor core along a shaft. A laminated iron core with slots for the stator windings makes up the stator of a salient pole generator. A three-phase system is normally created by connecting the stator windings in a three-phase arrangement. In response to the revolving magnetic field created by the rotor poles, the stator windings are what provide the induced voltage. The magnetic field in the rotor windings of a salient pole synchronous generator must be maintained, which depends on the excitation system. Through slip rings and brushes, direct current (DC) is provided to the rotor windings.

The rotor's magnetic field, produced by the excitation current, interacts with the stator windings to induce voltage. In comparison to non-salient pole generators, salient pole generators have higher stability characteristics. The generator can tolerate and recover from rapid changes in mechanical torque or electrical load thanks to the salient pole design's increased moment of inertia. This characteristic is crucial in power systems because the generator must retain stability and be able to resist disruptions. Salient pole generators also have the ability to handle greater short-circuit currents. Higher current carrying capacity is made possible by the pole windings' huge cross-sectional area, which is advantageous in power systems where fault currents might be sizable. The generator's ability to improve system fault-clearing and overall system reliability is improved by this capability. Salient pole generators do have some restrictions, though. Their inability to travel at high speeds is one of their key limitations. The rotor is mechanically stressed by the salient poles, and fast spinning speeds can generate centrifugal forces that harm or distort the rotor's construction. Salient pole generators are therefore often built to run at slower speeds than non-salient pole generators. A salient pole synchronous generator is a particular kind of synchronous generator distinguished by the design of its rotor. The salient pole design has benefits including better stability, higher short-circuit current handling capacity, and higher reactance. In large-scale power production applications where stability, dependability, and fault-clearing capabilities are crucial, these generators are frequently used. However, due to mechanical limitations, their operational speed is constrained.

**2. Cylindrical Rotor Synchronous Generator:** A dispersed winding is included on the cylinder rotor of a cylindrical rotor synchronous generator. Typically, the winding is encased in slots all the way around the rotor. Thermal power facilities frequently employ cylindrical rotor generators, which are appropriate for high-speed applications. The design of the rotor distinguishes a cylindrical rotor synchronous generator from other synchronous generator types. The rotor of a cylindrical rotor generator is smooth and cylindrical in shape, devoid of any projecting poles, in contrast to a salient pole synchronous generator. This design has some benefits and is frequently utilized in a range of power generation applications. A laminated steel solid rotor core is used in the manufacturing of cylindrical rotor synchronous generators. A prime mover, such as a steam turbine or a gas turbine, is used to propel the rotor core, which is positioned on a shaft. The rotor can be designed more simply and compactly because there are no salient poles. In a cylindrical rotor generator, the stator, not the rotor, typically houses the field winding.

A laminated iron core with slots for the stator windings makes up the stator. A three-phase system is normally created by connecting the stator windings in a three-phase arrangement. The spinning magnetic field necessary for the generator's operation is produced by these windings. The cylindrical rotor synchronous generator requires an external DC power source for

excitation in order to produce the magnetic field in the stator windings. An excitation system, which normally consists of a separate DC generator or an excitation transformer, provides the excitation current to the stator windings. The magnetic field in the stator can be created and controlled using the DC current provided by this excitation mechanism. Operating at high speeds is one of the benefits of a cylindrical rotor synchronous generator. Because there are no prominent poles, the rotor is less mechanically stressed and can handle faster rotational speeds. In situations where high-speed operation is necessary, such as in gas turbine power plants or other industrial operations, this characteristic is especially helpful. The enhanced cooling capabilities of cylindrical rotor generators is another benefit.

The rotor's smooth cylindrical design allows for improved airflow, which improves the cooling of the rotor core. Compared to salient pole generators, this leads to lower temperatures and better thermal performance. Efficiency and power factor control are two additional benefits of cylindrical rotor synchronous generators. The rotor's eddy current losses and hysteresis losses are decreased when conspicuous poles are absent, increasing overall efficiency. Furthermore, since the generator's power factor can be more precisely controlled thanks to the field winding's stator location, greater voltage management and power quality are made possible. It is important to keep in mind that cylindrical rotor synchronous generators could have some restrictions.

When compared to prominent pole generators, the absence of salient poles can result in less reactance. The transient stability and fault current handling capabilities of the generator may be impacted by this. Therefore, additional steps are required to reduce these difficulties, such as suitable system design and protective equipment. A synchronous generator with a cylindrical, smooth rotor and no projecting poles is known as a cylindrical rotor synchronous generator. High-speed operation, enhanced cooling, efficiency, and power factor control are just a few benefits of this design. When high-speed operation, a compact construction, and precision control are necessary, these generators are frequently used in a variety of power generation applications. When using cylindrical rotor generators in power systems, attention must be paid to reactance and transient stability issues.

**3. Brushless Synchronous Generator:** In order to excite the rotor, brushes and slip rings are not necessary with brushless synchronous generators. To provide the excitation current to the rotor windings, they employ a brushless excitation system that frequently relies on permanent magnets or spinning rectifiers. Compared to generators with brushes, brushless generators are more reliable and require less maintenance. A brushless synchronous generator, usually referred to as a brushless alternator, is a kind of synchronous generator that does away with the brushes and slide rings that are frequently present in conventional generators. This design has a number of benefits, including increased performance, decreased maintenance, and higher reliability. Brushes and slip rings are employed in a conventional synchronous generator to transport the excitation current to the rotor winding, which produces the magnetic field.

But in order to maintain optimum operation, brushes and slip rings need to be cleaned and replaced on a regular basis. Brushless synchronous generators get around these restrictions by using different kinds of stimulation. A spinning rectifier assembly installed on the rotor shaft normally makes up the excitation system of a brushless synchronous generator. The alternating current generated in the stator windings is transformed into direct current (DC) using diodes or other solid-state components found in this assembly. After that, the rotor windings receive the



DC power, doing away with brushes and slide rings in the process. Similar to a conventional generator, the stator of a brushless synchronous generator is made of a laminated iron core with slots for the stator windings. A three-phase system is created by connecting the stator windings, which are organized in three phases. The generator's output of alternating current (AC) is produced by these windings. A brushless synchronous generator's increased reliability is one of its main benefits.

There are no wearable parts or components that need routine maintenance because there aren't any brushes or slide rings involved. This lowers the likelihood of failures and increases the generator's overall reliability, making it appropriate for situations where continuous running is essential. Reduced maintenance requirements are also a result of the absence of brushes and sliding rings. The costs and downtime related to the generator's maintenance are greatly decreased by not needing to replace, adjust, or clean the brushes and slide rings on a regular basis. As a result, brushless synchronous generators are ultimately more economical and efficient. In comparison to conventional generators, brushless synchronous generators also provide improved performance. The efficiency of the generator is increased by cutting down on the electrical losses caused by brushes and slide rings. Furthermore, brushless generators offer greater voltage management and control, producing reliable and high-quality electricity. Moreover, complex control and monitoring systems can be added to brushless synchronous generators. The performance of the generator, including voltage, current, frequency, and other factors, can be continuously monitored by these systems. In order to guarantee the generator's safe and dependable functioning, they permit real-time changes and offer protection systems.

Many different businesses and power generation systems use brushless synchronous generators. They are frequently used in standby generators, mobile power units, and backup power systems where dependability, low maintenance requirements, and excellent performance are crucial. They are also used to transform mechanical energy into electrical energy in renewable energy systems like wind turbines and hydroelectric plants. A brushless synchronous generator, as the name implies, does away with the necessity for brushes and slip rings in the excitation system. This design has benefits like increased performance, decreased maintenance needs, and higher reliability. In many different applications, brushless generators are frequently utilized, especially in backup power systems and renewable energy systems where dependability, low maintenance, and high performance are essential.

**4. Self-Excited Synchronous Generator:** Synchronous generators that can generate the required excitation current for the rotor windings on their own are known as self-excited generators. They either rely on the initial current provided by an additional winding known as an exciter or residual magnetism in the rotor. Self-excited generators are frequently employed in standby or small-scale applications. A synchronous generator that can provide its own excitation without the use of an external excitation device is known as a self-excited synchronous generator. Self-excited generators produce the required magnetic field for operation using their own output voltage, in contrast to other types of generators that need an additional excitation source. In synchronous generators, self-excitation can be attained in a number of ways. The electromechanical, permanent magnet, and capacitor types of techniques are the most popular.

a. **Capacitor Excitation:** A capacitor is linked in parallel with the generator's stator winding in capacitor-excited synchronous generators. The remaining magnetism in the rotor core of the generator causes a modest voltage to be induced in the stator windings when the generator begins to rotate. The capacitor is charged by the induced voltage, which also produces an excitation current. The rotor magnetic field is subsequently made stronger by the excitation current, increasing voltage generation[7]–[9].

b. **Electromechanical Excitation:** In electromechanical self-excitation, the generator makes use of a tiny auxiliary DC generator called a revolving exciter or a pilot exciter. DC power is generated by the pilot exciter, which is connected to the generator shaft. The magnetic field is produced by the generator's rotor windings, which receive this DC power. The generator shaft may or may not incorporate the revolving exciter as a separate component.

c. **Permanent Magnet Excitation:** In place of electromagnets or field windings, permanent magnets installed on the rotor are used in permanent magnet self-excitation. It is not necessary to use external excitation since permanent magnets provide a magnetic field that is constant. The magnetic field created by the rotating rotor creates voltage in the stator windings, which causes self-excitation and energy production.

The generator runs like a typical synchronous generator after the self-excitation is created. Three-phase AC voltage is generated as a result of the interaction between the revolving magnetic field created by the rotor poles and the stator windings. Applications for this AC voltage range from power production to industrial operations to electrical supply. Small-scale power production systems, including portable generators, small industrial applications, and backup generators for homes, frequently employ self-excited synchronous generators. Since these generators don't need external excitation devices, they are straightforward, small, and economical.

However, compared to generators with independent excitation systems, they might be constrained in terms of voltage regulation and control. Self-excited synchronous generators can be fitted with voltage control systems to get over the problems with voltage regulation. These devices, like automated voltage regulators (AVRs), keep an eye on the voltage at the generator's output and regulate the excitation current to keep it stable. The precise voltage control offered by AVR systems ensures that the generator output stays within predetermined bounds. A self-excited synchronous generator is a kind of synchronous generator that has the ability to generate its own excitation without the help of an outside excitation source. They use a variety of techniques to create the magnetic field necessary for power production, including capacitor, electromechanical, or permanent magnet excitation. Self-excited generators are frequently employed in small-scale applications where cost efficiency and simplicity are crucial. To maintain steady and dependable functioning, however, voltage regulation techniques, such as automatic voltage regulators, may be required.

5. **Permanent magnet synchronous generators (PMSGs):** The magnetic field is produced by permanent magnets inside the rotor of PMSGs. These generators have benefits including increased efficiency, smaller size, and less maintenance because they don't need a separate excitation system. In wind turbines and other renewable energy sources, PMSGs are frequently used. The magnetic field required for power generation is created by permanent magnets on the rotor in permanent magnet synchronous generators (PMSGs), a particular type of synchronous

generator. PMSGs are ideal for a variety of applications, including electric vehicle propulsion and renewable energy systems, thanks to their high efficiency, small size, and improved dependability. A PMSG is made up of a revolving rotor and a stator that are both stationary. A laminated iron core with slots for the stator windings makes up the stator. A three-phase system is normally created by connecting the stator windings in a three-phase arrangement. When three-phase alternating current (AC) is applied to these windings, the spinning magnetic field is produced.

Permanent magnets, commonly composed of neodymium iron boron (NdFeB) or samarium cobalt (SmCo), are installed on the rotor of a PMSG. A fixed magnetic field is created by positioning the permanent magnets in a precise manner. Electrical power is produced as a result of the interaction between the fixed magnetic field of the permanent magnets and the spinning magnetic field created by the stator windings. The great efficiency of PMSGs is one of their main benefits. Permanent magnets are used instead of rotor windings, which eliminates the need for excitation losses that are generally present in conventional generators. PMSGs are a popular option for energy conversion systems as a result of the decreased electrical losses and increased general efficiency that follow from this. PMSGs are also renowned for their lightweight construction and compact size. The construction is made simpler by the lack of field windings and excitation mechanisms, resulting in a smaller, lighter generator. This characteristic is especially helpful in applications like electric cars and portable power systems where weight and space restrictions are crucial. Comparing PMSGs to generators with field windings, better dependability is another benefit.

The permanent magnets don't need upkeep or external excitation and have a lengthy working life. By doing away with the need for brushes, slide rings, or commutators, less wear and maintenance is required. PMSGs offer improved dependability and a longer service life as a result. Especially in wind turbines, PMSGs are widely used in renewable energy systems. PMSGs are ideal for cheaply and efficiently capturing wind energy due to their high efficiency and compact size. They are also used in hydroelectric power facilities, which use PMSGs to transform the rotational motion of water turbines into electrical power. In addition, PMSGs are used in electric vehicles (EVs). PMSGs are ideal for electric propulsion systems due to their high power density, lightweight construction, and increased efficiency. PMSGs in EVs help to increase energy efficiency and prolong the driving range. Power electronics converters and control systems are used to regulate and control the voltage output of PMSGs. To meet the needs of the connected electrical grid or the particular load, these systems modify the frequency and voltage of the generated electricity. To sum up, permanent magnet synchronous generators (PMSGs) are synchronous generators that rely on permanent magnets on the rotor to produce the magnetic field required for power production. They provide benefits like increased reliability, compact size, and great efficiency. PMSGs are frequently employed in electric vehicles, renewable energy systems, and a variety of other applications where high dependability, compactness, and efficiency are essential.

**6. Wound Rotor Synchronous Generator:** The rotor windings of wound rotor synchronous generators are coupled to external resistors or a changeable external circuit. This enables the generator's output characteristics, such as voltage regulation and reactive power management, to vary under control. When certain operating characteristics are required, such as in big industrial facilities or grid stabilization systems, wound rotor generators are utilized in specialized

applications. An example of a synchronous generator is a wound rotor generator, which generates power by using the magnetic field produced by wound rotor windings on the rotor. Wound rotor generators use electromagnets on the rotor to create the magnetic field, as opposed to permanent magnet synchronous generators (PMSGs), which rely on permanent magnets. A stator and a rotor are components of a wound rotor synchronous generator. A laminated iron core with slots for the stator windings makes up the stator.

A three-phase system is normally created by connecting the stator windings in a three-phase arrangement. When three-phase alternating current (AC) is applied to these windings, the spinning magnetic field is produced. A wound rotor synchronous generator has field windings or electromagnets on the rotor. Through slip rings and brushes, these windings are connected to an external DC power supply. The rotor windings receive a DC current from the external power source, which generates the magnetic field required for power production. Usually, the rotor windings are coupled in a star or delta pattern. The magnetic field produced by the rotor windings and the stator windings interact when the device is in operation. This interaction causes the stator windings to experience voltage, which produces electricity. The speed of rotation and the quantity of poles on the stator and rotor affect the output voltage and frequency of the generator. The capacity to better manage the generated power is one of the benefits of wound rotor synchronous generators.

The voltage and reactive power output of the generator can be adjusted by changing the excitation current sent to the rotor windings. This functionality is especially helpful in applications like grid-connected power systems where accurate voltage and power factor management is necessary. Utility power plants and other large-scale power generation systems, as well as industrial applications, frequently employ wound rotor synchronous generators. Compared to other generator types, these generators offer better stability and fault tolerance. The generator can more effectively tolerate and recover from system disturbances, such as abrupt load shifts or failures, by modulating the excitation current. Additionally, the use of wound rotor windings increases the generator's design and operational flexibility. To meet the needs of a particular power system, the rotor windings can be simply changed or modified. Due to their adaptability, wound rotor generators can be used in a variety of grid layouts and operational environments. Wound rotor synchronous generators do, however, also have significant drawbacks. Slip rings and brushes bring up possible wear and tear as well as upkeep requirements. To guarantee good operation, these components must be regularly inspected, cleaned, and replaced. Furthermore, compared to other generator types, the generator is more expensive and complex overall due to the inclusion of rotor windings.

A wound rotor synchronous generator is a kind of synchronous generator that makes use of the wound rotor windings on the rotor to provide the magnetic field needed for power production. They have benefits like better stability, more design freedom, and higher control over voltage and reactive power. In large-scale power generation systems, where precise control and stability are essential, wound rotor generators are frequently utilized. However, the presence of slip rings and brushes adds complexity and requires maintenance. It's crucial to note that generator and alternator refer to the same device that transforms mechanical energy into electrical energy, and they are frequently used interchangeably. Depending on the situation and location, there may be a difference between the two names. These are a few examples of the standard synchronous

generator and alternator types. The choice of a specific kind is influenced by the application, power needs, operating environment, and required control capabilities.

**Difference between Synchronous Generator and Synchronous Alternator:** Alternators and synchronous generators are two examples of electrical devices used to produce alternating current (AC). Despite having identical operating principles, synchronous generators and alternators differ greatly from one another. Let's delve more into these distinctions:

1. **Configuration:** The configuration of synchronous generators and alternators is the key distinction between them. In synchronous generators, the stator is the component that is stationary, while the rotor rotates. The field winding that creates the revolving magnetic field is inside the rotor. Alternators, on the other hand, have a rotor and a stator, with the rotor being stationary and the stator rotating. In alternators, the field winding, which creates the revolving magnetic field, serves as the rotor.

2. **Synchronization:** Synchronous generators need to be synchronized with a third-party power grid. In order to ensure effective operation and power transfer, they must match the frequency and phase of the grid. An excitation system that manages the magnetic field of the rotor allows for synchronization. On the other hand, alternators can work independently and do not require synchronization with a third-party grid. They deliver power at the voltage and frequency needed by the connected load[10].

3. **Voltage Regulation:** Another aspect that sets synchronous generators and alternators apart from one another is voltage regulation. Modern voltage regulation methods are more common in synchronous generators. The synchronous generator's excitation system enables accurate control of the rotor's magnetic field, enabling voltage regulation to uphold constant output voltage levels. To regulate and change the output voltage in accordance with the demands of the load, alternators frequently rely on external voltage regulators.

4. **Size and Power Output:** Synchronous generators are massive and have high power outputs, making them ideal for large-scale power generation. They are frequently employed in utility-scale applications and power plants. On the other hand, alternators are more suited to smaller-scale applications due to their typical lower size. They are frequently utilized in mobile or off-grid power applications, portable generators, and automotive systems.

5. **Applications:** Thermal power facilities, hydroelectric power plants, and wind farms all use synchronous generators extensively. They offer the grid with a dependable and coordinated power supply. Alternators are used in a wide range of situations and industries, including portable generators, construction machinery, aircraft, and automotive systems. They are frequently employed to supply electricity in off-the-grid regions, operate electrical systems, and charge batteries.

The configuration, synchronization requirements, voltage regulation systems, size, power output, and uses of synchronous generators and alternators vary. Alternators are more portable, adaptable, and independent power sources appropriate for smaller-scale and mobile applications. Synchronous generators are typically utilized in large-scale power generation and require synchronization with an external grid. When choosing the right electrical machine for a particular application, it is crucial to comprehend these differences.



**Applications of Synchronous Generator and Synchronous Alternator:** Synchronous generators and synchronous alternators are used in a variety of locations and industries. Let's look at how each is applied:

**Synchronous Generator Applications:**

- a. **Power Plants:** Synchronous generators are widely utilized in power facilities, including wind farms, hydroelectric power plants, and thermal power plants. On a big scale, they are in charge of transforming mechanical energy into electrical energy. These power plants generate electricity, which is then sent to the grid for distribution to consumers in the residential, commercial, and industrial sectors.
- b. **Renewable Energy Systems:** Synchronous generators are frequently utilized in renewable energy systems, including wind farms and hydroelectric power plants. Synchronous generators transform the rotational energy from wind or water turbines into electrical energy. For effective power transfer, these generators make sure the electricity generated is coordinated with the grid's frequency and voltage.
- c. **Industrial Applications:** Synchronous generators are used in a variety of industrial settings where a steady and dependable power supply is necessary. They are employed in sectors like petrochemicals, mining, oil and gas, and manufacturing. When the grid is down, synchronous generators supply backup power to keep crucial machinery and processes running continuously.
- d. **Emergency Power Systems:** Synchronous generators are a crucial component of emergency power systems, including standby generators and backup generators. These generators are made to provide electricity in case of crises like blackouts. To guarantee uninterrupted operation and avoid disturbances, they are frequently deployed in hospitals, data centers, telecommunications facilities, and other essential infrastructure.
- e. **Applications in the Marine and Offshore Sector:** Synchronous generators are extensively employed in the marine and offshore sectors. They supply maritime vessels, offshore platforms, and ships with electrical power. In order to provide electricity for propulsion, lighting, HVAC systems, and other onboard electrical systems, synchronous generators can be powered by engines or turbines.

**Synchronous Alternator Applications:**

- a. **Automotive Systems:** Synchronous alternators are frequently utilized in automobile systems. They are frequently found in vehicles, trucks, buses, and motorbikes to provide electrical power for operating different electrical systems, including lights, ignition systems, infotainment systems, and other onboard electronics. They also serve to charge the vehicle's battery.
- b. **Airplanes:** Synchronous alternators produce electrical power for a variety of uses in airplanes. They supply energy for vital aircraft systems such the avionics, lighting, communication, and navigation systems. Synchronous alternators guarantee a steady power supply while the aircraft is in flight, helping to ensure its safe operation.
- c. **Construction Equipment:** Excavators, bulldozers, cranes, and compactors are just a few examples of the construction machinery that uses synchronous alternators. They

provide the necessary electricity to run the equipment's electrical systems, including the hydraulics, lighting, and onboard electronics. This heavy-duty equipment have a dependable power supply in synchronous alternators.

- d. **Portable Generators:** Synchronous alternators are frequently utilized in portable generators. These generators are made to offer supplemental or temporary electricity for outdoor activities, in isolated regions, or at night. For generating AC power in portable generators used for camping, outdoor events, construction sites, and emergency circumstances, synchronous alternators offer a small and effective alternative.
- e. **Off-grid Power Systems:** Synchronous alternators are used in off-grid power systems, which are those that do not have access to a central power grid. These systems are frequently employed in isolated locations, rural areas, and small towns. Synchronous alternators offer a dependable and independent power supply for off-grid applications when paired with suitable power sources, like diesel engines or renewable energy systems.

These are a some of the most common uses for synchronous generators and alternators. Both devices are crucial in producing AC power for numerous sectors, infrastructure, and daily uses, guaranteeing that there is always access to electricity when and when it is required.

## CONCLUSION

Alternators and synchronous generators are essential electrical devices used to produce alternating current (AC) electricity. Both of them work using the electromagnetic induction principle, which states that a spinning magnetic field causes a voltage to be induced in the stator windings. These devices have a wide range of uses in industrial settings, renewable energy systems, and power plants. In order to transform mechanical energy into electrical energy, the synchronous generator is often coupled to a prime mover, such as a turbine or an engine. To create the magnetic field in the rotor and ensure synchronization with the grid frequency, a direct current (DC) excitation system is necessary. Large power facilities frequently use synchronous generators to supply electricity to the grid. An alternator, on the other hand, is a particular kind of synchronous generator created for mobile and small-scale applications. It is frequently utilized in vehicles, airplanes, and portable generators. To produce AC power, alternators also rely on an excitation system and rotating magnetic field. In conclusion, synchronous generators and alternators are essential for producing and distributing electricity. Alternators offer a portable and adaptable solution for modest power generation needs, but synchronous generators are best suited for large-scale applications. Designing effective and dependable electrical systems requires a thorough understanding of the concepts and operation of these devices.

## REFERENCES:

- [1] Electrical4U, "Alternator Synchronous Generator And Types of Alternators," *Electrical 4 U*, 2019.
- [2] Electrical4U, "Armature Reaction in Alternator or Synchronous Generator," <https://www.electrical4u.com/>, 2020.
- [3] V. Ostovic, J. M. Miller, V. K. Garg, R. D. Schultz, and S. H. Swales, "A magnetic-equivalent-circuit-based performance computation of a lundell alternator," *IEEE Trans.*

- Ind. Appl.*, 1999, doi: 10.1109/28.777190.
- [4] J. Riedemann *et al.*, “Design and building of an automatic alternator synchronizer based on open-hardware arduino platform,” *IEEE Access*, 2019, doi: 10.1109/ACCESS.2019.2932294.
- [5] S. K. Sahdev, “Synchronous Generators or Alternators,” in *Electrical Machines*, 2019. doi: 10.1017/9781108355582.007.
- [6] C. He and T. Wu, “Analysis and Design of Surface Permanent Magnet Synchronous Motor and Generator,” *CES Trans. Electr. Mach. Syst.*, 2019, doi: 10.30941/CESTEMS.2019.00013.
- [7] J. S. Artal-Sevil, R. Dufo, M. Astaneh, J. A. Domínguez, and J. L. Bernal-Agustín, “Development of a small wind turbine for stand-alone system in rural environment. Reuse and recycling of electric motors,” *Renew. Energy Power Qual. J.*, 2018, doi: 10.24084/repqj16.455.
- [8] J. Sohn, S. Hong, and M. Sunwoo, “Alternator torque model based on equivalent circuit of synchronous generator for electric power management,” *IEEE Trans. Veh. Technol.*, 2013, doi: 10.1109/TVT.2013.2266416.
- [9] M. A. Awadallah and M. M. Morcos, “A fuzzy-logic-based AVR for a stand-alone alternator feeding a heater load,” *IEEE Power Eng. Rev.*, 2001, doi: 10.1109/MPER.2001.4311076.
- [10] M. Kozak, “Alternating Current Electric Generator Machine Inverters in a Parallel Power Sharing Connection,” *IEEE Access*, 2019, doi: 10.1109/ACCESS.2019.2902647.

## SYNCHRONOUS MOTOR: THEORY, MODELING, AND APPLICATIONS

**Mr. Veerappa Ravi\***

\*Assistant Professor,  
Department of Electrical And Electronics Engineering,  
Presidency University, Bangalore, INDIA  
Email Id-raviangadi@presidencyuniversity.in

---

### ABSTRACT:

*A common type of AC motor utilized in many industrial and commercial applications is the synchronous motor. They are renowned for their capacity to run at a fixed speed set by the power supply's frequency and the motor's number of poles. The frequency of the power source and the quantity of poles in the motor define the speed at which the synchronous motor, a type of AC motor, runs. To accomplish synchronous operation, this motor relies on the idea of magnetic field synchronization between the stator and rotor. In this chapter, we give a general review of synchronous motors, covering their design, functionality, and uses.*

**KEYWORDS:** *Cylindrical Rotor, Excited Synchronous Motors, Synchronous Motor, Non-Excited Synchronous Motors.*

---

### INTRODUCTION

A common type of AC motor utilized in many industrial and commercial applications is the synchronous motor. They are renowned for their capacity to run at a fixed speed set by the power supply's frequency and the motor's number of poles. By synchronizing the magnetic fields of the motor's stator and rotor, this fixed speed operation is made possible. We will examine synchronous motors' operating principle, construction, features, benefits, and applications in this in-depth introduction to them. The complexities of synchronous motor operation, such as the idea of magnetic field synchronization and the numerous types and configurations of synchronous motors, will be thoroughly discussed[1]–[3].

**Synchronous Motors:** A common type of AC (alternating current) electric motor utilized in many industrial and commercial applications is the synchronous motor. They are renowned for their fine-grained speed regulation, excellent efficiency, and capacity to sustain constant speed under a variety of load circumstances. We shall examine the advantages, applications, and working theory of synchronous motors in this introduction. A synchronous motor works on the basis of synchronism between the rotating magnetic field generated by the stator, which is the motor's stationary component, and the rotor, which is the revolving component. Synchronous motors, unlike induction motors, need an outside power source to generate a spinning magnetic field in the rotor. The rotor windings are normally supplied with direct current from this external power source, which is typically a DC (direct current) excitation system. The stator and the rotor are the two fundamental components that make up a synchronous motor. The stator's core, windings, and frame are all parts of the stator. When linked to a three-phase AC power source,

the stator windings, which are typically organized in a three-phase configuration, are responsible for creating a rotating magnetic field.

The rotor, on the other hand, is made up of field windings and a rotor core. The DC power supply excites the field windings, which produces a magnetic field that interacts with the stator's revolving magnetic field. A synchronous motor's operation is dependent on the interaction of the magnetic fields of the rotor and stator. A spinning magnetic field is produced when three-phase AC power is applied to the stator windings. The DC power source excites the field windings on the rotor, which produces a constant magnetic field. The rotor rotates at a synchronous speed that depends on the frequency of the AC power source and the number of poles in the motor due to the interplay of these two magnetic fields. Synchronous motors have the capacity to run at a constant speed regardless of the load conditions, which is one of their key benefits. They are perfect for applications that need accurate speed control, such as industrial motors, process control systems, and synchronous generators, due to this property. Synchronous motors are an energy-efficient option for many applications due to their great efficiency.

A further benefit of synchronous motors for power factor correction in electrical systems is that their power factor is controllable by altering the excitation current. Numerous industries, including oil and gas, pulp and paper, mining, chemical processing, and power generation, use synchronous motors extensively. They are frequently utilized in sizable pumps, conveyors, mills, compressors, and other heavy machinery that needs great torque and controlled speed. Power plants use synchronous generators to generate electricity and synchronize with the grid. Synchronous motors are adaptable devices that have great speed control, high efficiency, and the capacity to sustain steady speed under a variety of load circumstances. Their design, which is based on how magnetic fields interact, enables accurate control and dependable functioning. These motors are widely used in commercial and industrial settings, where they help keep a variety of machines and systems running effectively and dependably.

**Working principle of Synchronous Motor:** The idea of synchronism between the magnetic fields created by the revolving stator and the rotor serves as the foundation for the operation of synchronous motors. Synchronous motors, unlike induction motors, need an outside power source to generate a spinning magnetic field in the rotor. A revolving magnetic field forms inside the stator when a three-phase AC power source is coupled to the stator windings. The stator's number of poles affects how quickly the magnetic field rotates. Let's use a four-pole motor as an illustration. In this instance, the magnetic field completes one rotation (360 degrees) in two cycles of the AC power supply (i.e., a speed of 3600 RPM with a 60 Hz power source). A separate DC power source is used to excite the field windings that make up the synchronous motor's rotor. A stationary magnetic field is produced in the rotor by the DC power source's direct current flowing through the rotor windings. The revolving magnetic field of the stator interacts with this magnetic field.

The speed of the revolving magnetic field generated by the stator and the speed of the stationary magnetic field in the rotor must be equal for the motor to run in synchronism. In other words, the stator's spinning magnetic field "locks onto" the rotor's stationary magnetic field. The rotor must first be initially accelerated toward the synchronous speed via external means in order to establish this synchronism. The term "synchronous starting" refers to the action of getting the rotor close to synchronous speed by the use of an auxiliary motor or other devices. The DC



excitation is applied once the rotor is getting close to the synchronous speed, at which point the rotor synchronizes with the stator's revolving magnetic field. Once the synchronous motor is running, no matter what load is put on it, it keeps its speed constant. This characteristic results from the stator and rotor's built-in synchronism. The motor adjusts the torque to match the load when the load on it varies, but the speed doesn't. The synchronous motor is useful for applications that need precise speed control, such industrial drives and process control systems, because it can maintain a steady speed. Additionally, leading power factor operation of synchronous motors enables power factor correction in electrical systems, enhancing efficiency and lowering energy usage. The synchronism between the rotor's stationary magnetic field and the stator's spinning magnetic field is essential to a synchronous motor's operation. By giving the rotor a DC stimulation, the rotor can lock onto the revolving magnetic field of the stator and establish synchronism. The motor is beneficial in applications demanding precise speed control and excellent efficiency since it maintains a constant speed independent of the load.

## DISCUSSION

**Construction of Synchronous Motor:** Synchronous motors are made of a number of essential parts that come together to make the motor function. The stator, rotor, excitation system, and supporting structures are some of these parts. Let's examine each of these aspects individually:

- a. **Stator:** The stator is the component of a synchronous motor that is stationary. A stator core, stator windings, and a stator frame make up the device. Eddy current losses are decreased by the stator core's construction of layered laminations of high-grade electrical steel. In order to create a sturdy framework with slots for the stator windings, the laminations are glued together. Typically, the stator windings are organized into a dispersed winding with three phases. The stator frame offers the stator core and windings mechanical support and security.
- b. **Rotor:** The synchronous motor's revolving component is known as the rotor. It consists of a field winding and a rotor core. Additionally constructed from laminated electrical steel, the rotor core is attached to the motor shaft. To reduce eddy current losses, the laminations are separated from one another by insulation. The field windings are attached to an external DC power supply and are looped around the rotor core. The field windings are excited by the DC power source, which produces a magnetic field in the rotor that interacts with the revolving magnetic field in the stator.
- c. **Excitation System:** The excitation system provides the rotor field windings with DC current. It typically consists of control circuits and a DC power source, like a generator or rectifier. To adjust the size and polarity of the DC current and hence the strength and direction of the rotor magnetic field, the excitation system. The power factor and efficiency of the synchronous motor can be managed by changing the excitation current.
- d. **Structures Supporting Synchronous Motors:** Synchronous motors are housed in strong frames that offer mechanical support and safety. The frames are created to withstand the mechanical forces and vibrations that occur during operation and are frequently composed of cast iron or steel. The frames also serve as mounting locations for the bearings that support and guarantee the smooth rotation of the motor shaft.

Additionally, additional parts like cooling systems that aid in dissipating heat produced during operation may be included with synchronous motors. To keep components at their ideal

operating temperatures, a variety of cooling techniques, such as air or liquid cooling, can be used. The stator, rotor, excitation system, and supporting structures are all parts of the building of synchronous motors. The rotor's field windings, which are energized by a DC power source, produce the spinning magnetic field, while the stator's stator windings generate the stationary magnetic field. To regulate the motor's performance, the excitation system controls the excitation current. Synchronous motors may operate efficiently and dependably in a variety of industrial and commercial applications because to their strong construction and accurate design.

**Characteristics of Synchronous Motor:** Synchronous motors are distinguished from other types of motors by a number of features. Selecting the right motor for a given application requires an understanding of these properties. The following are some synchronous motors' salient features:

- a. **Synchronization:** The frequency and number of poles of the AC power supply are in synchronism with how synchronous motors operate. The frequency of the power supply and the quantity of poles in the motor determine the synchronous speed, which the rotor turns at precisely. Synchronous motors are ideal for applications that require constant speed due to the exact speed control made possible by their synchronous action.
- b. **Constant Speed:** Regardless of the load, synchronous motors operate at a constant speed. The rotor revolves at synchronous speed after locking onto the stator's revolving magnetic field. The motor adjusts its torque to fit the load even if the load changes, maintaining a constant speed. In applications where precise speed control and synchronization with other equipment are necessary, this property is helpful.
- c. **High Efficiency:** Synchronous motors are well renowned for their excellent efficiency. Especially when faced with heavy loads, they outperform induction motors in terms of efficiency. Their increased effectiveness is a result of the absence of rotor losses like copper and iron losses. Synchronous motors are frequently used in situations where high energy efficiency and low running costs are required [4]–[6].
- d. **Power Factor Correction:** Synchronous motors are capable of operating at a leading power factor. The excitation current can be changed to alter the motor's power factor. Leading power factor operation lowers the reactive power drawn from the power grid and contributes to an improvement in the power factor of electrical systems as a whole. When power factor correction is required to increase the effectiveness of electrical systems, synchronous motors are used.
- e. **Starting Methods:** Synchronous motors need particular starting techniques to get them toward synchronous speed before synchronization can take place. Common beginning techniques include accelerating the rotor to nearly synchronous speed with electrical drives, pony motors, or auxiliary motors. The excitation system is turned on when the motor is almost at synchronous speed, and the rotor then locks into synchronism with the revolving magnetic field of the stator.
- f. **Control and Stability:** Synchronous motors are incredibly stable and have good control. By accurately regulating the excitation current, their speed may be managed. Synchronous motors are useful for applications that need precise speed control, like industrial drives, robotics, and precision control systems, because to this capability. Synchronous motors also

have strong stability against disturbances and can react swiftly to modifications in load circumstances.

- g. **Applications:** Synchronous motors have a wide range of uses in the energy, pulp and paper, oil and gas, chemical processing, and other industries. Large industrial machinery including compressors, pumps, fans, mills, and conveyors frequently employ them because they offer accurate speed control, great efficiency, and power factor adjustment.

In Summary, Synchronization, consistent speed, high efficiency, power factor correction, precision control, and stability are just a few of the distinctive qualities of synchronous motors. They are appropriate for a variety of applications thanks to these qualities, where accurate speed control, energy efficiency, and power factor enhancement are crucial.

**Types of Synchronous Motor:**Based on the methods used for field excitation, there are basically two types of synchronous motors: non-excited (also known as reluctance motors) and excited (also known as synchronous generator/motors or salient pole motors). Let's investigate each kind in greater depth:

1. **Non-Excited (Reluctance) Synchronous Motors:** Reluctance motors, also known as non-excited synchronous motors, work on the basis of magnetic reluctance. These motors rely on the rotor's innate resistance to create a spinning magnetic field because they lack a separate field excitation device. The rotor of a reluctance motor is constructed of salient poles on a laminated steel core. Due to magnetic attraction and a desire to reduce magnetic reluctance, the stator windings produce a revolving magnetic field that causes the rotor poles to align themselves with the stator field. The rotor rotates in accordance with the spinning magnetic field as the rotor poles line up with the stator field. Reluctance motors are frequently utilized in low-power applications where ease of use and affordability are crucial considerations. A separate DC excitation source for the rotor is not necessary with non-excited synchronous motors, also referred to as reluctance synchronous motors.

Reluctance synchronous motors rely on the principle of magnetic reluctance to produce torque and achieve synchronous operation, as opposed to conventional synchronous motors, which use field windings and excitation systems. We shall review the advantages, applications, and working theory of non-excited synchronous motors in this topic. Non-excited synchronous motors operate on the basis of the rotor's magnetic reluctance. The term reluctance describes a magnetic circuit's resistance to the transmission of magnetic flux. The salient poles of the rotor of a non-excited synchronous motor are built with magnetically soft material. Compared to the surrounding air or non-magnetic areas, these poles have a lower magnetic reluctance. As a result, a rotating magnetic field is created when three-phase AC power is applied to the stator windings. To reduce magnetic resistance, the rotor poles align themselves with the stator magnetic field. This produces a torque that drives the rotor in synchronism with the stator field. A stator, rotor, and control system make up a non-excited synchronous motor's construction. A three-phase design of stator windings makes up the stator, which is comparable to that of a typical synchronous motor. As was already indicated, the rotor is constructed with magnetically soft material for the salient poles.

The control system is in charge of controlling the power supplied to the stator windings and preserving the synchronization between the fields of the rotor and stator. Compared to conventional synchronous motors, non-excited synchronous motors provide a number of

benefits. They simplify the motor design and lower maintenance needs by doing away with the necessity for a separate DC excitation system. Cost reductions and increased dependability result from this. Second, the lack of losses related to the excitation mechanism allows reluctance synchronous motors to operate at high efficiencies. The strong torque characteristics of these motors also enable smooth and accurate regulation of rotational speed. In many different industries where precise speed control and excellent efficiency are necessary, non-excited synchronous motors are used. They are frequently employed in fields like robotics, automation, and motion control technology.

For applications that require variable speed operation, such as machine tools, textile machines, packaging equipment, and conveyor systems, reluctance synchronous motors are appropriate. They are ideal for applications demanding quick acceleration and deceleration because to their high torque density and ability to provide precise speed control. Reluctance synchronous motors, also known as non-excited synchronous motors, provide a special method for achieving synchronous operation without the requirement for a separate excitation mechanism. These motors offer accurate speed control, high efficiency, and exceptional torque characteristics by relying on the magnetic reluctance concept. They are used in many different industries, especially in systems that need quick responses and variable speed control. Non-excited synchronous motors are an excellent choice for many industrial and commercial applications due to their simplicity, dependability, and performance.

**2. Excited (Synchronous Generator/Motor or Salient Pole) Synchronous Motors:** In order to produce a magnetic field in the rotor, excited synchronous motors also referred to as synchronous generator/motors or salient pole motors need a separate DC excitation system. In order to create a magnetic field, these motors have field windings on the rotor that are activated by a DC power source. The rotor rotates at synchronous speed as a result of the interaction between the revolving magnetic field created by the stator and the magnetic field of the rotor. Excited synchronous motors can be further divided into different groups according to the rotor construction: In order to achieve synchronous operation, excited synchronous motors also referred to as synchronous generators or salient pole synchronous motors excite the rotor windings.

These motors are frequently employed in industrial applications needing precise speed control as well as in power generation, where they serve as synchronous generators. We shall review the advantages, applications, and working theory of excited synchronous motors in this topic. The interaction between the magnetic fields of the stator and rotor is the foundation of the operation of excited synchronous motors. Similar to non-excited synchronous motors, excited synchronous motors use three-phase AC electricity to energize the stator windings, which results in a revolving magnetic field. In contrast, the rotor of excited synchronous motors has field windings that are coupled to an additional DC power source called the excitation system. The rotor windings receive direct current from the excitation system, which generates a magnetic field that interacts with the stator's rotating magnetic field.

The stator, rotor, and excitation system make up the structure of excited synchronous motors. Similar to other synchronous motor stator designs, this one includes stator windings arranged in three phases. Salient poles, which are extensions or projections from the rotor core, are incorporated into the rotor's design. These salient poles house the field windings, which are

linked to the excitation system. The rectifiers, regulators, and control devices that are part of the excitation system deliver the proper DC current to the rotor windings. Excited synchronous motors have a number of benefits for industrial and power generation applications. One of their main benefits is their capacity to produce electricity at a steady frequency, which makes them perfect for power generation and grid synchronization. Additionally, these motors have good efficiency and excellent voltage regulation.

Additionally, excited synchronous motors provide accurate speed control, making them appropriate for uses like robotics, CNC machines, and paper mills that demand precise speed and position control. Excited synchronous motors are widely used in power plants as synchronous generators that transform mechanical energy into electrical energy. They are frequently employed in thermal, hydroelectric, and renewable energy systems like wind turbines. Excited synchronous motors are used in industrial settings in a variety of equipment and systems like compressors, pumps, fans, and conveyors that demand great precision and speed control. Excited synchronous motors, often referred to as synchronous generators or salient pole synchronous motors, depend on the excitation of rotor windings to accomplish synchronous operation. They have benefits including steady output frequency, great voltage regulation, high efficiency, and accurate speed control. These motors are widely employed in power generation and a variety of industrial applications where accurate and dependable performance is necessary.

a. **Cylindrical Rotor:** Synchronous motors with cylindrical rotors have a cylindrical rotor. The field windings are positioned parallel to the rotor shaft on the surface of the rotor. These motors are frequently employed in high-power settings like power plants, where a lot of electrical power is produced or transformed. A rotor design that is frequently utilized in synchronous motors and generators is the cylindrical rotor. It has a cylindrical shape, with a rotor core that is also cylindrical in nature. The cylindrical rotor design has some benefits in terms of manufacturing simplicity, construction quality, and performance. We shall examine the characteristics, operation, benefits, and applications of cylindrical rotor designs in this talk. The steel or another magnetically permeable material, such as solid or laminated cylindrical core, makes up the cylindrical rotor. To reduce eddy current losses, rotor cores typically consist of a stack of laminations.

The windings for the rotor are inserted into slots on the rotor's surface or deep inside the core. Depending on the motor design, the windings are coupled to create one or more sets of poles. The interaction between the magnetic fields of the stator and the rotor is the foundation of the operation of cylindrical rotor synchronous motors and generators. A spinning magnetic field is produced when three-phase AC power is applied to the stator windings. The revolving magnetic field of the stator interacts with the windings of the rotor, which are energized by a different DC power source. This contact produces torque and synchronizes the magnetic fields of the rotor and stator. Synchronous motor and generator designs with cylindrical rotors have a number of benefits. Their sturdy construction, which enables excellent mechanical strength and stability, is one of their main features. A strong construction that can bear high mechanical loads and centrifugal forces is provided by the solid cylindrical core. The cylindrical rotor design also provides excellent thermal characteristics, enabling effective heat dissipation and better cooling. The applicability of cylindrical rotor designs for high-speed applications is another benefit.



The rotor's balanced design and symmetrical construction help to boost stability at high rotational speeds while reducing vibrations. Because of this, synchronous motors and generators with cylindrical rotors are well suited for high-speed applications like turbo-generators, centrifugal compressors, and turbo equipment. Numerous industrial applications frequently use cylindrical rotor designs. They are used in large-scale synchronous generators that produce electricity in thermal, hydroelectric, and nuclear power facilities. The grid receives consistent and dependable electrical power from these generators. Cylindrical rotor synchronous motors are utilized in industrial settings for big pumps, compressors, fans, and rolling mills where accurate speed control, high torque, and stability are crucial. Synchronous motors and generators with cylindrical rotor designs have advantages in terms of design, functionality, and high-speed operation. The cylindrical rotor's sturdy and well-balanced structure offers mechanical stability, little vibration, and effective cooling. Power generating and other industrial applications that call for dependable, high-performance electrical devices frequently adopt this design[7]–[9].

**b. Salient Pole Rotor:** Salient pole synchronous motors have rotors with salient poles that stick outward. These salient poles are wrapped in the field windings. Typically, there aren't many salient poles, which results in better torque characteristics at slower speeds. Large industrial compressors and pumps, as well as other applications requiring significant starting torque, frequently use salient pole motors. A typical rotor design found in synchronous motors and generators is the salient pole rotor. It is distinguished by having projecting poles on its surface that are equally placed all the way around the rotor's diameter. Specific benefits are provided by the salient pole rotor design in terms of construction, performance, and control. We shall analyze the salient pole rotor designs' characteristics, operating idea, benefits, and applications in this discussion. The salient pole rotor has a magnetically permeable rotor core constructed of laminated steel or some similar material. Salient poles, which resemble protrusions or teeth and extend outward from the surface of the core, are present. These poles are activated by DC field windings and are magnetically distinct from one another. To produce a magnetic field inside the rotor, the field windings are wound around the poles and connected to a different DC power source.

The interaction between the magnetic fields of the stator and the rotor is the foundation for the operation of salient pole rotor synchronous motors and generators. A spinning magnetic field is produced when three-phase AC power is applied to the stator windings. The interaction between the revolving magnetic field of the stator and the magnetic field created by the rotor poles causes torque to be produced and synchronizes the magnetic fields of the rotor and stator. Synchronous motor and generator designs with salient pole rotors have a number of benefits. One of its main benefits is their capacity to produce strong torque at low speeds. Larger air gaps between the protruding poles and the stator winding enable a higher magnetic reluctance, which strengthens magnetic interactions and boosts torque generation. Because of this, salient pole rotor machines are appropriate for heavy-duty pumps, crushers, and mills that demand significant starting torque.

The adaptability of salient pole rotor designs in terms of control and excitation is another benefit. The distinct DC field windings provide fine-grained control of the rotor magnetic field, allowing modifications to the machine's performance parameters including reactive power compensation and power factor management. Because of this, salient pole rotor machines are well suited for applications involving grid synchronization and voltage regulation as well as power system

stability and control. Many industrial and power generation applications use salient pole rotor designs. They are frequently used in large-scale synchronous generators in power plants, such as wind turbine generators, hydroelectric generators, and generators from thermal power plants. The grid receives consistent and dependable electrical power from these generators. Applications include industrial drives, fans, blowers, and printing presses that call for high torque and precise control use prominent pole rotor synchronous motors. In summary, synchronous motors and generators with prominent pole rotor designs have advantages in terms of high torque production, control flexibility, and stability.

They are excellent for high beginning torque applications due to their projecting poles and wider air gaps, which boost torque at low speeds. Performance characteristics can be fine-tuned thanks to the precise control and excitation provided by the independent DC field windings. Power generating and other industrial applications that call for reliable, high-performance electrical machines frequently use salient pole rotor machines. Both varieties of excited synchronous motors enable power factor adjustment, accurate speed control, and good efficiency. They are excellent for a variety of applications, including industrial drives, generators, power systems, and more thanks to their design and properties. There are two primary categories of synchronous motors: non-excited (reluctance) and stimulated synchronous generator/motor or salient pole. While excited motors need a separate DC excitation source to produce a rotating magnetic field, non-excited motors run on magnetic reluctance. Based on the rotor design, the excited motors can also be divided into salient pole or cylindrical rotor motors.

**Advantage of Synchronous Motor:** Synchronous motors are a popular option for many applications because they provide a number of benefits over other motor types. Here are a few of synchronous motors' main benefits:

1. **Precision Speed Control:** Synchronous motors offer great precision speed control, enabling fine-grained control of rotational speed. Due to the frequency of the AC power source and the quantity of poles in the motor, they run at a constant speed known as the synchronous speed. Because of this characteristic, synchronous motors are appropriate for uses including industrial drives, robotics, and precision machines that need for reliable and exact speed control.
2. **High Efficiency:** Synchronous motors are well renowned for their excellent efficiency. Compared to other motor types, such induction motors, they often function at a greater efficiency level. This effectiveness is related to synchronous motors' lack of rotor losses and their capacity to keep their power factor near to unity. Reduced energy use, financial savings, and increased environmental sustainability are all benefits of high efficiency.
3. **Power Factor Correction:** Synchronous motors are a viable option for power factor correction in electrical systems. The excitation current that is supplied to the rotor windings can be changed to alter the motor's power factor. This feature enhances the system's total power factor, lowering the need for reactive power and enhancing the effectiveness of the electrical distribution system.
4. **Constant Speed Operation:** Regardless of the load circumstances, synchronous motors operate at a constant speed. Changes in the applied load or fluctuations in the supplied voltage have no impact on them. They are particularly suited for applications that need a

consistent and continuous speed, including synchronous clocks and generators in power plants, because of this property.

5. **Torque Capability:** Synchronous motors are well suited for applications requiring high starting torque or severe load circumstances due to their high torque capability. Since high torque is necessary for starting and operating big weights in industrial machinery like pumps, compressors, and conveyors, this characteristic makes them a good fit.
6. **Reactive Power Support:** Synchronous motors are capable of offering the electrical grid reactive power support. They can produce or absorb reactive power as needed by altering the excitation current, which helps to control the voltage and stabilize the grid. Synchronous motors are advantageous in power system stability and control due to this property, particularly in large-scale power generation and distribution systems [10].
7. **Reliability and Durability:** Synchronous motors are renowned for their dependable design and strong construction. They are built to resist demanding applications, challenging working environments, and repeated start-stop cycles. Synchronous motors have a long operational life and offer dependable performance with little downtime and maintenance expenses with proper maintenance.

Synchronous motors are the favored option for many different industries and applications, including power generation, industrial machinery, robotics, HVAC systems, and more because to these benefits. Their precise speed regulation, high efficiency, and other qualities boost performance, save energy, and increase system dependability as a whole.

**Applications of Synchronous Motors:** Synchronous motors are used in many different systems and sectors because of their unique advantages and qualities. Here are a few typical uses for synchronous motors:

1. **Power Generation:** Synchronous generators, which are simply synchronous motors run backward, are widely employed in power plants to produce electricity. By rotating at a consistent speed and matching the frequency of the electrical grid, they transform mechanical energy into electrical energy. Thermal power plants, hydroelectric power plants, wind turbines, and other renewable energy systems all use synchronous generators.
2. **Industrial Machinery:** Synchronous motors are used in a variety of industrial machinery and equipment that calls for highly precise speed control. They are frequently found in crushers, pumps, fans, mixers, conveyors, and compressors. These motors operate with dependability and efficiency, guaranteeing precise speed control and a strong starting torque for heavy loads.
3. **Robotics and Automation:** Synchronous motors are essential components of robotics and automation systems that call for accurate and synchronized movement. Robotic arms, CNC machines, automated production systems, and other devices that require precise control over rotational speed, location, and synchronization all make use of them.
4. **HVAC Systems:** Synchronous motors are used in HVAC systems, which include heating, ventilation, and air conditioning. To ensure dependable and effective performance, they are employed in pumps, fans, and air handling devices. Synchronous motors ensure consistent

speed operation and accurate regulation of air flow rates for the best HVAC system performance.

5. **Synchronous Clocks:** Synchronous clocks, where precision and synchronization are essential, frequently employ synchronous motors. These clocks, which are normally powered by the frequency of the electrical grid, ensure accurate timekeeping by operating at synchronous speed. In public spaces, railroad stations, airports, and other sites where precise timekeeping is necessary, synchronized clocks are used.
6. **Aerospace and Defense:** Synchronous motors are used in applications in the aerospace and defense industries. They are utilized in a variety of aircraft systems, including the landing gear, engine control, and flight control surfaces. In challenging aircraft conditions, synchronous motors provide precise control, high torque, and dependable operation.
7. **Alternative Energy Systems:** Synchronous motors are used in alternative energy systems, including wave energy converters and tidal power generation. These motors provide a dependable and effective method of utilizing renewable energy sources by converting the mechanical energy from the tides or waves into electrical energy.
8. **Power System Stability and Control:** Synchronous motors are used in applications that involve the stability and control of power systems. They support power factor correction, reactive power compensation, and voltage regulation. By supplying or absorbing reactive power as necessary, synchronous condensers, which are synchronous motors run without mechanical loads, are used to maintain electrical grids.

These are but a few instances of the numerous uses for which synchronous motors are put to use. They are excellent for a variety of industries and systems that demand dependable, efficient, and precisely regulated rotating motion due to their exact speed control, high efficiency, power factor control, and other advantages.

## CONCLUSION

Due to their benefits like high efficiency, precise speed control, and dependable performance, synchronous motors are extensively employed in a variety of sectors. These motors are useful for applications requiring constant speed, such as in power plants, industrial operations, and electric vehicle propulsion systems, due to their synchronous functioning. The motor works at a set speed, ensuring steady operation and reliable output thanks to the magnetic field synchronization between the stator and rotor. Synchronous motors continue to be an essential component of contemporary electrical systems thanks to continual developments in motor control technology, which increase performance and energy economy.

## REFERENCES:

- [1] X. Sun, L. Chen, and Z. Yang, "Overview of bearingless permanent-magnet synchronous motors," *IEEE Trans. Ind. Electron.*, 2013, doi: 10.1109/TIE.2012.2232253.
- [2] J. Faiz and H. Nejadi-Koti, "Demagnetization Fault Indexes in Permanent Magnet Synchronous Motors-An Overview," *IEEE Trans. Magn.*, 2016, doi: 10.1109/TMAG.2015.2480379.
- [3] W. Deng and S. Zuo, "Electromagnetic vibration and noise of the permanent-magnet

- synchronous motors for electric vehicles: An overview,” *IEEE Transactions on Transportation Electrification*. 2019. doi: 10.1109/TTE.2018.2875481.
- [4] Y. Ye, F. Peng, and Y. Huang, “Overview of Multi-Motor Synchronous Motion Control Technology,” *Diangong Jishu Xuebao/Transactions of China Electrotechnical Society*. 2021. doi: 10.19595/j.cnki.1000-6753.tces.200343.
- [5] R. T. Ugale, B. N. Chaudhari, and A. Pramanik, “Overview of research evolution in the field of line start permanent magnet synchronous motors,” *IET Electr. Power Appl.*, 2014, doi: 10.1049/iet-epa.2013.0241.
- [6] T. J. Vyncke, K. Boel, J. A. A. Melkebeek, and R. K. Boel, “Direct Torque Control of Permanent Magnet Synchronous Motors – An Overview,” *3rd Benelux Young Res. Symp. Electr. Power Eng.*, 2006.
- [7] E. Gundabattini, A. Mystkowski, R. Raja Singh, and S. D. Gnanaraj, “Water cooling, PSG, PCM, Cryogenic cooling strategies and thermal analysis (experimental and analytical) of a Permanent Magnet Synchronous Motor: a review,” *Sadhana - Acad. Proc. Eng. Sci.*, 2021, doi: 10.1007/s12046-021-01650-z.
- [8] I. Boldea, “Electric generators and motors: An overview,” *CES Trans. Electr. Mach. Syst.*, 2020, doi: 10.23919/tems.2017.7911104.
- [9] K. Ullah, J. Guzinski, and A. F. Mirza, “Critical Review on Robust Speed Control Techniques for Permanent Magnet Synchronous Motor (PMSM) Speed Regulation,” *Energies*. 2020. doi: 10.3390/en15031235.
- [10] vishal thakur and A. SHARMA, “Overview of Electric Scooter Operating on Synchronous Reluctance Motor (Synrm),” *SSRN Electron. J.*, 2021, doi: 10.2139/ssrn.3979093.



## SPECIALIZATION INDUCTION MACHINE: PRINCIPLES, DESIGN, AND ANALYSIS

**Mr. Vesapogu Joshi\*\***

\*Associate Professor,  
Department of Electrical And Electronics Engineering,  
Presidency University, Bangalore, INDIA  
Email Id-joshimanohar@presidencyuniversity.in

### ABSTRACT:

*An electrical machine with many industrial applications is the induction machine. It is a favored option for many power systems due to its durability, dependability, and affordability. This presentation gives a general review of the field of induction machines, emphasizing its core ideas, developments, and applications. The objective is to give a thorough overview of the subject while highlighting the most recent findings and advancements. Included in the list of topics are rotor design, stator winding arrangements, control schemes, and optimization methods. The report also analyzes the possibility for future improvements of induction machines and the effect of specialization on their performance and efficiency.*

**KEYWORDS:** *Induction Machine, Rotating Magnetic Field, Squirrel-Cage Induction Machine, Wound-Rotor Induction Machine.*

### INTRODUCTION

Asynchronous or induction machines are a class of electric motor or generator utilized extensively in a wide range of commercial and industrial applications. They are known as induction machines because the electromagnetic induction principle is how they work. A stator and a rotor are part of an induction machine's fundamental design. The stator is made out of an iron laminated core with regularly spaced slots for insulated copper windings. A revolving magnetic field is created when an alternating current (AC) is run via the stator windings. On the other hand, the rotor can be either a wound rotor or a squirrel cage rotor. The laminated iron cores of the squirrel cage rotor have conductive bars or short-circuited copper or aluminum conductors inserted into the slots. The three-phase windings of the wound rotor are connected to the outside world through slip rings and brushes. The electromagnetic induction principle serves as the foundation for an induction machine's operation. The rotor windings experience voltage and current induction when the stator's revolving magnetic field cuts across the rotor's conductors.

The rotor rotates because of an interaction between the magnetic fields produced by the induced current and the magnetic field of the stator. The rotor of an induction machine rotates at a little slower rate than the stator-generated spinning magnetic field. Slip is the term for this discrepancy, which enables the induction machine to produce torque. The slip and torque produced by the motor increase with increasing motor load. Induction machines are renowned for their dependability, durability, and affordability. They are widely utilized in many different applications, including those requiring mechanical power, such as industrial machinery, pumps,

compressors, fans, conveyors, and many other devices. They are also frequently used as generators in power plants. It's crucial to note that my knowledge cutoff date for induction machines is September 2021, thus there may have been developments since then[1]–[3].

**Working principle of Induction Machine:**One of the most often used electric motors in a variety of applications, from industrial gear to home appliances, is the induction machine, commonly referred to as the asynchronous motor. It works on the electromagnetic induction theory, which Michael Faraday discovered at the beginning of the 19th century. An induction machine's operation relies on the interplay of magnetic fields and electric currents to generate mechanical rotation. The stator and the rotor are the two primary parts of an induction machine. The machine's rotating component is the rotor, while the stator is its stationary component. A set of windings in the stator are connected to an alternating current (AC) power supply and are organized in a certain configuration. On the other hand, the rotor can be either a wound rotor or a squirrel cage rotor. A rotating magnetic field is produced when the stator windings are coupled to the AC power supply.

The interplay of the AC current and the configuration of the stator windings results in the rotating magnetic field. The number of poles in the stator windings controls how quickly the magnetic field rotates. A three-phase induction motor, which has three sets of stator windings separated by 120 degrees, is the most typical design. Let's now take a look at the squirrel cage rotor, the most popular rotor type utilized in induction machines. The cylindrical rotor is made of laminated iron cores that have conducting bars placed in them. The bars, which resemble a squirrel cage, are shorted at each end by conducting rings. Due to the electromagnetic induction principle, when the revolving magnetic field from the stator reaches the rotor, it induces a voltage in the rotor bars. Electric currents pass through the rotor bars as a result of the induced voltage. Lenz's law states that the rotor currents' direction opposes the change in the magnetic field that causes them. As a result, the revolving magnetic field of the stator interacts with the magnetic field produced by the rotor currents.

The torque created by this contact leads the rotor to begin rotating in the same direction as the magnetic field. The rotating magnetic field rotates at a little slower rate than the rotor. Slip, or the difference in speed, is required for the induction machine to work. The torque is produced by the rotor currents, which are produced by the slip between the revolving magnetic field and the rotor conductors. As soon as it begins rotating, the induction machine runs on its own. The slip lessens as the rotor picks up speed, bringing it closer to the synchronous speed, or the speed of the revolving magnetic field. The slip is zero at synchronous speed, and the magnetic fields of the stator and rotor conductors are stationary. As a result, no voltage is induced in the rotor bars, which prevents the formation of any rotor currents or torque. The induction machine has a number of benefits, including straightforward design, durability, and few maintenance needs. Due to its effectiveness, dependability, and capacity to manage a range of loads, it is widely employed. It does, however, have significant drawbacks, such as slower speed control than other motor types. The creation of a spinning magnetic field in the stator of an induction machine causes currents to be induced in the conductors of the rotor through electromagnetic induction. The rotor rotates as a result of the torque created by the magnetic fields of the stator and rotor interacting. The induction machine can effectively transform electrical energy into mechanical energy for a variety of applications thanks to this self-sustaining operation.

**Construction of Induction Machine:** An induction machine, also known as an induction motor, is built from a number of essential parts that cooperate to make it work. Let's look at the design of a conventional three-phase squirrel cage induction motor shown in Figure 1, the most prevalent design utilized in a variety of applications.

1. **Stator:** The stator, which is the induction machine's stationary component, generates the rotating magnetic field. It consists of a laminated iron core with slots for the stator windings on the inner periphery. In order to create many poles, the stator windings, which are commonly constructed of copper or aluminum, are placed in a certain configuration. The intended speed and the motor's performance characteristics determine the number of poles.
2. **Rotor:** The induction machine's revolving component is known as the rotor. The rotor of a squirrel cage induction motor is made up of laminated iron cores that are stacked vertically to form a cylindrical shape. The iron core slots contain the rotor conductors, which are typically constructed of aluminum or copper bars. The bars are shorted at each end by conducting end rings, giving the device the appearance of a squirrel cage, hence the name "squirrel cage rotor." Induced currents go through the rotor conductors, creating the rotor magnetic field and torque.
3. **Bearings:** The rotor shaft is supported by the bearings, which also enable smooth rotation. Typically, either ball bearings or sleeve bearings are used in induction devices. Sleeve bearings are simpler and less expensive, frequently used in less demanding applications, while ball bearings offer lower friction and higher precision, making them suited for high-performance applications.
4. **End Shields:** The end shields protect the stator and rotor and support the motor mechanically. They are firmly fastened to the stator frame and commonly made of steel or cast iron.
5. **Frame:** The exterior structure that connects all the components together is called the frame. It gives the motor's internal components mechanical strength and defense. Typically, cast iron, steel, or an alloy of aluminum is used to create the frame.
6. **Ventilation System:** Induction machines produce heat while they are operating, so a good ventilation system is necessary to keep the temperature of the motor within reasonable bounds. Through apertures in the frame and the employment of cooling fans, ventilation is made possible, helping to dissipate the heat produced by the motor.
7. **Terminal Box:** The terminal box, which is on the outside of the motor, is where the electrical connections are kept. It offers a practical location for attaching the motor to the power source and enables the connection of control components, including thermal overload relays and safety equipment.
8. **Insulation System:** The motor's electrical insulation between its many components must be maintained at all times. Short circuits are avoided, and electrical breakdown is guarded against. The stator windings, rotor conductors, and other important components are covered with insulating tapes, enamel, varnish, mica, and other materials.

The main parts of a conventional squirrel cage induction motor are as follows. Depending on the particular motor design and intended application, extra features and components like as cooling

fins, vibration sensors, and noise reduction techniques may also be present. An induction machine's precise structure and design may change depending on elements including power rating, efficiency requirements, climatic conditions, and needs for a particular application.

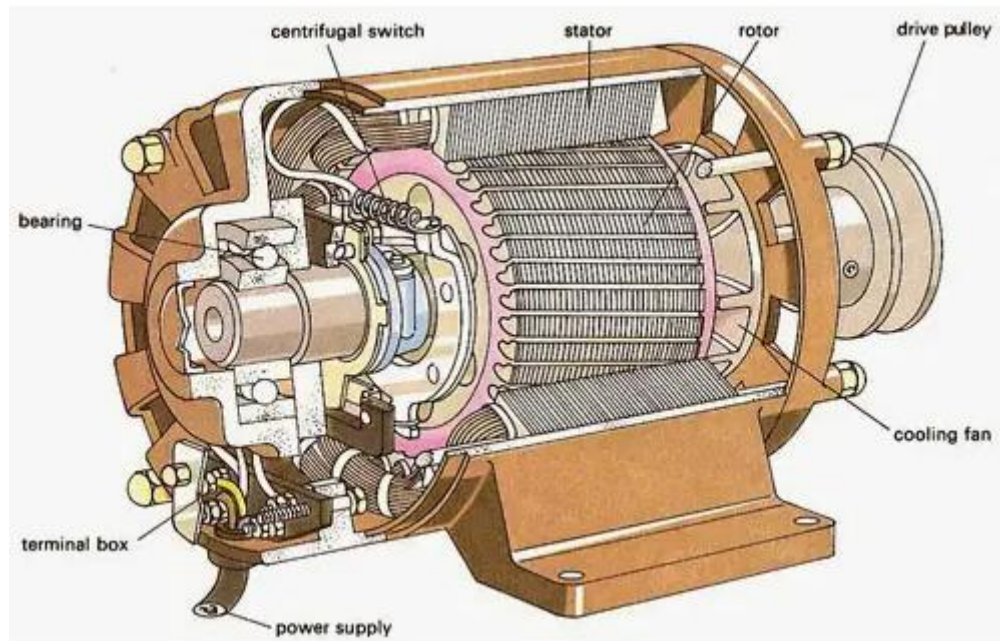

**Figure 1: Construction of Three Phase Induction Motor [StudyElectrical].**

## DISCUSSION

**Types of Induction Machine:** Based on the type of rotor construction, there are basically two types of induction machines Figure 1 squirrel cage induction machines and wound rotor induction machines. Let's investigate each kind in greater depth:

**1. Squirrel Cage Induction Machines:** The most prevalent and commonly utilized type of induction motor is the squirrel cage induction machine. They are appropriate for a variety of applications because to their straightforward and durable design. The term squirrel cage refers to the rotor's look, which is similar to a squirrel cage wheel. The rotor is made up of short-circuited conducting bars often comprised of aluminum or copper that are inserted into slots between laminated iron cores. Conducting end rings link the bars at both ends. A spinning magnetic field is created when an AC voltage is given to the stator windings. This rotating magnetic field causes currents to be created in the rotor bars. The magnetic field created by these induced currents in the rotor bars interacts with the revolving magnetic field of the stator to produce torque and cause the rotor to rotate.

Machines with squirrel cage induction are renowned for their ease of use, affordability, strong starting torque, and toughness. However, their ability to control speed is rather limited. Due to their durability, simplicity, and affordability, squirrel cage induction machines, sometimes known as induction motors, are widely employed in many different fields and applications. These electromagnetic electric motors have a stator and a rotor and work on the electromagnetic principle. The operation, design, benefits, and applications of squirrel cage induction devices will all be covered in this article. The interaction between the magnetic field generated by the stator



and the induced currents in the rotor is the basis of the operation of a squirrel cage induction machine. A laminated iron core with slots that can hold the stator winding, which is normally a three-phase winding, makes up the stator. A rotating magnetic field is produced when the stator winding receives three-phase alternating electricity. Currents in the rotor conductors are generated by this revolving magnetic field and are short-circuited by the end rings to create a closed loop[4]–[6].

A squirrel cage induction machine's rotor is constructed of laminated iron cores with "squirrel cage" conductors, or conductive bars, placed evenly between them. These conductors are inserted into the rotor slots and are commonly constructed of copper or aluminum. The term comes from the fact that the conductors' configuration and form resemble a squirrel cage. A magnetic field that opposes the magnetic field of the stator is created when the rotating magnetic field interacts with the conductors of the rotor. The rotor rotates as a result of the interaction's torque. The ease of building of squirrel cage induction devices is one of their key benefits. The lack of slip rings and brushes, which are found in other types of motors, decreases the likelihood of mechanical failure and removes the need for maintenance. Squirrel cage motors are extremely dependable and appropriate for continuous operation in challenging conditions because to their sturdy design.

The versatility of squirrel cage induction machines to work at different speeds is another benefit. The speed of the spinning magnetic field can be changed by varying the frequency of the supplied current, allowing for different motor speeds. Due of this characteristic, squirrel cage induction motors can be used in conveyors, pumps, and fans, among other devices that need to be able to control speed. The high starting torque of squirrel cage induction motors is well recognized for allowing them to start big loads. The differential in speed between the revolving magnetic field and the rotor allows for the creation of this beginning torque. The relative speed is high when the motor is first turned on, which causes a high starting torque. The torque reduces and reaches a steady-state value when the rotor nears its synchronous speed (the speed of the rotating magnetic field). Squirrel cage induction devices have a fairly high efficiency, often between 85% and 95%. They are more cost- and energy-effective because of this efficiency. Additionally, because squirrel cage motors have a high-power factor and use less reactive power, they increase the quality of the electricity and lower the load on the electrical grid.

A variety of businesses use squirrel cage induction machines. They are frequently employed in industrial processes where sturdy and dependable motors are needed, such as pumps, compressors, blowers, and conveyors. Due to its effectiveness and low maintenance needs, squirrel cage motors are also frequently employed in HVAC systems, refrigeration units, and domestic appliances. Squirrel cage motors are utilized in the automobile industry to power the traction and auxiliary systems in electric and hybrid vehicles. In summary, squirrel cage induction machines are flexible and often employed electric motors that work by interacting between the revolving magnetic field of the stator and the induced currents in the conductors of the rotor. They are appropriate for a wide variety of applications across numerous industries thanks to their simplicity, resilience, variable speed capability, high starting torque, and efficiency. Squirrel cage induction machines continue to be a key component of the technology that powers our contemporary world because to continual improvements in motor technology.



**2. Wound Rotor Induction Machines:** Compared to squirrel cage machines, wound rotor induction machines, sometimes referred to as slip ring induction machines or wound rotor motors, have a more intricate design. A laminated iron core with three-phase windings that resemble the stator windings make up the rotor. The winding ends of the rotor are carried out to external terminals using slip rings and brushes, unlike squirrel cage rotors. The rotor windings can be connected to extra external circuits or external resistance thanks to the slip rings. Greater control over the motor's performance is made possible by this feature, which also makes it possible to use features like variable speed and strong beginning torque. The torque and speed characteristics of the motor can be changed by adjusting the external resistance linked to the rotor windings. Applications requiring precise speed control, including big industrial drives, hoists, and elevators, frequently use wound rotor induction devices.

Due to its simplicity, dependability, and affordability, squirrel cage induction machines account for the bulk of induction machines used in a variety of applications. Typically, wound rotor induction machines are used in applications that call for sophisticated control capabilities and variable speed needs. The decision between the two types is influenced by a number of variables, including the needs of the application, the required level of control, and cost concerns. When compared to squirrel cage induction motors, wound rotor induction motors also referred to as slip ring induction motors offer a few advantages and features. We shall examine the advantages, applications, and working theory of wound rotor induction devices in this article. A winding rotor induction machine operates on a similar concept as a squirrel cage induction machine. Its stator and rotor, both of which are necessary for the motor to function, make up this component.

Similar to other induction motors, the stator is made of a laminated iron core with slots for the stator winding. When supplied with alternating power, the stator winding typically a three-phase winding generates a revolving magnetic field. A wound rotor induction machine's rotor is distinct from a squirrel cage rotor. The rotor is made out of a three-phase winding with several coils and exterior terminals connected to slip rings rather than short-circuited conductive bars. These slip rings enable the connection of external resistors or other circuits to the rotor windings. The external resistors combine to provide an external resistance circuit that is programmable, allowing the torque and speed characteristics of the motor to be altered. The rotor windings experience a voltage when the motor is running because of the stator's revolving magnetic field. The rotor windings experience current flow as a result of this induced voltage. Slip rings and external resistors offer a way to regulate the rotor current and, as a result, the torque and speed of the motor.

The torque-speed characteristic of the motor can be changed by altering the resistance connected to the rotor windings. The capability of wound rotor induction devices to produce high beginning torque is one of its key benefits. The motor can generate a larger starting torque compared to squirrel cage induction machines by including external resistors in the rotor circuit. Due to this characteristic, wound rotor motors are appropriate for large pumps, crushers, and mills as well as other machinery that requires significant starting torque. The flexibility to modify speed control is another benefit of wound rotor induction machines. The torque-speed curve of the motor can be changed, enabling speed control over a broad range, by altering the resistance connected to the rotor windings. This qualifies wound rotor motors for uses including crane systems, winders, and conveyor belts where precise speed control is required. Additionally, wound rotor induction machines display favorable efficiency and power factor traits.

Although slightly less than squirrel cage motors, wound rotor motor efficiency can still be quite good. Additionally, by modifying the external resistance, the motor's power factor can be enhanced, lowering the need for reactive power from the power source. Numerous systems and businesses use wound rotor induction devices. They are frequently employed in sectors including mining, cement, and metal processing where changeable speed control and strong beginning torque are crucial. Elevators, escalators, and hoists are just a few examples of equipment that uses wound rotor motors for fine control over speed and torque. They are also used in systems that require soft starting to lessen the mechanical strain on the powered equipment. Compared to squirrel cage induction machines, wound rotor induction machines offer a number of advantages, including a high beginning torque and customizable speed control. They offer flexibility in a variety of applications due to its capacity to alter the torque-speed characteristics through external resistance. Despite having a little lower efficiency than squirrel cage motors, wound rotor induction machines are nonetheless very important in sectors where their unique qualities are needed.

**Importance of Induction Machine:**Both squirrel cage and winding rotor types of induction machines are very important in many different fields and applications. Here are several major justifications for the importance of induction machines:

- a. **Versatility:** Induction machines are flexible and useful in a variety of settings. They are typically found in transportation, HVAC, home appliances, industrial operations, and renewable energy systems. Their capacity to offer dependable and effective power conversion and control underpins their adaptability.
- b. **Cost-effectiveness:** When compared to other kinds of electric machines, induction machines are less expensive. With no brushes or slip rings (in the case of squirrel cage motors) or a straightforward rotor winding configuration (in the case of wound rotor motors), they have a rather straightforward construction. They are an affordable option for a variety of applications due to their simplicity, which lowers manufacturing costs.
- c. **Reliability and Toughness:** Induction machines are renowned for their dependability and toughness. They can work in demanding conditions including dust, humidity, and vibration without noticeably degrading performance. In squirrel cage motors, the lack of brushes and slip rings minimizes a frequent cause of wear and maintenance, enhancing overall reliability.
- d. **High Efficiency:** The normal efficiency range for induction machines is between 85% and 95%. Because of its great efficiency, industrial and commercial applications use less energy and spend less money on operational expenses. By limiting power losses and lowering carbon emissions, it also helps to sustain the environment.
- e. **Induction Motor Control:**To satisfy particular application needs, induction machines provide a variety of control systems. Frequency control, voltage control, or rotor resistance control (in wound rotor motors) can all be used to regulate speed. Induction machines are able to respond to various load circumstances thanks to their flexible control [7]–[9].
- f. **High Starting Torque:** Because squirrel cage induction machines have a high starting torque, they can start huge loads without the aid of external devices. This trait is especially useful in applications with high inertia loads or high torque requirements during initiation.

- g. **Maintenance-Free Operation:** Because they don't have brushes or slip rings, squirrel cage induction machines require very little maintenance. As a result, they are more suitable for applications where continuous operation is essential since downtime and maintenance costs are reduced.
- h. **Power Factor Improvement:** Induction machines can help electrical systems with their power factor. The reactive power demand from the power supply can be minimized, improving the overall power quality and system efficiency, by applying effective power factor correction techniques and capacitor banks.
- i. **Integration with Renewable Energy:** Systems using renewable energy can be effectively integrated with induction machines. Their durability, dependability, and capacity for variable speed operation make them suitable for use in wind turbines and hydroelectric power generation.
- j. **Legacy and Market Dominance:** Induction machines have a mature market with well-established infrastructure and support and have been used extensively for many years. Induction machines are a popular option for many applications because to their availability and the substantial knowledge and skill in their design, operation, and maintenance. Induction machines, then, are extremely important in many different sectors and applications because of their adaptability, affordability, robustness, reliability, high efficiency, and controllability. They provide a variety of systems' power conversion and control requirements, promoting energy efficiency, sustainability, and dependable operation.

**Impact of Specialization of Performance and Efficiency:** Specialization has a considerable effect on the functionality and effectiveness of induction devices. In comparison to generic off-the-shelf machines, specialist induction machines can achieve greater performance and increased energy economy through customization and optimization. The following are some significant ways that specialization affects effectiveness and performance:

- a. **Improved Torque Production:** Induction machines' ability to produce torque can be enhanced by the use of specialized rotor designs like skewed or double-cage rotors. For a particular machine size, these designs maximize the magnetic field distribution, increasing torque output. The induction machine's overall performance is improved by increased torque output, which enables it to carry heavier loads or run at slower speeds.
- b. **Reduced Losses:** Specialization enables the induction machine to experience less losses overall, which boosts productivity. Losses from resistive, iron, and stray losses can be reduced by optimizing the architecture of the rotor and stator as well as the material choice. Lower energy consumption and increased machine efficiency are the results of reduced losses.
- c. **Customized regulation methods:** For precise regulation of torque and flux in induction machines, specialized control methods, such as vector control or model predictive control, are used. These cutting-edge control strategies optimize the machine's performance, resulting in better dynamic responsiveness and energy economy. For particular applications, specialized control algorithms can also be created, improving performance and efficacy there.

- d. **Optimal Winding Configurations:** Specialization enables stator winding configurations to be tailored to meet particular application needs. It is possible to apply concentrated windings or fractional slot windings to reduce copper losses and increase machine effectiveness. The induction machine can function more effectively and save energy if the winding configuration is adjusted to the load profile of the application.
- e. **Optimization of Design Parameters:** Design parameter optimization is made possible through specialization, which includes improvements in shape, material choice, and operating circumstances. The most effective solutions can be discovered by using mathematical simulation, modeling, and optimization techniques. Design optimization takes into account elements like electromagnetic performance, mechanical stress, and thermal management, resulting in a machine that is well-tailored and performs at its best.
- f. **Application-Specific Performance:** Specialization enables induction machines to be tailored to meet certain application needs. For instance, the machine can be adjusted for high-torque applications to give the maximum amount of torque while maintaining efficiency. Control techniques can be tailored for variable speed applications to offer precise speed control and energy savings. Performance and efficiency can be improved by customizing the machine to the unique requirements of the application.

Specialization has a clear effect on the functionality and effectiveness of induction machines. Specialized induction machines can produce more torque, reduce losses, increase control, and generally operate more efficiently by customizing, optimizing, and modifying them to particular application needs. Benefits from this include lower operating expenses, better system performance, and energy savings. The performance and effectiveness of induction machines in a variety of applications can surely be further improved by the investigation and development of specialized approaches.

**Applications of Induction Machines:** Due to their durability, dependability, and affordability, induction machines are used in a wide range of sectors. The following are some typical uses for induction machines:

- a. **Industrial Machinery:** Industrial machinery, including pumps, compressors, fans, conveyors, and machine tools, frequently uses induction machines. They are perfect for powering and managing a variety of industrial operations because of their capacity to withstand heavy loads, offer flexible speed control, and function in severe settings.
- b. **HVAC Systems:** Heating, ventilation, and air conditioning (HVAC) systems frequently use induction devices. They provide reliable and effective performance for the fans and blowers that are used in buildings to circulate air and control temperature.
- c. **Electric Vehicles:** The propulsion systems of electric vehicles (EVs) utilise induction machinery. They supply the required torque and speed management for dependable and efficient vehicle operation. Due to their benefits including high power density, regenerative braking, and reliable performance, induction machines are appropriate for EV applications.
- d. **Renewable Energy Systems:** Induction machines are crucial components of renewable energy sources, especially in wind turbines and hydropower generators. They transform water or wind energy's mechanical energy into electrical energy. Due to its versatility in

managing varying loads and speeds, induction machines are ideal for capturing renewable energy sources.

- e. **Household Appliances:** Appliances used in the home include washing machines, refrigerators, air conditioners, and dishwashers. These appliances use induction technology. They contribute to the overall energy efficiency and performance of these appliances by ensuring efficient and dependable functioning [10].
- f. **Treatment of Water and Wastewater:** Pumps, mixers, and aerators are frequently powered by induction motors in water and wastewater treatment facilities. They ensure effective water and wastewater treatment by providing dependable operation, ruggedness, and the capacity to manage a range of flow rates and loads.
- g. **Oil and Gas Sector:** Drilling rigs, compressors, pumping systems, and other equipment all make use of induction machines in the oil and gas sector. They are ideal for the rigorous requirements of the industry due to their dependability, resilience, and capacity to function in difficult settings.
- h. **Mining Operations:** Conveyor systems, crushers, and grinding mills are just a few of the applications for which induction machines are used in mining. They are ideal for mining operations due to their capacity to manage big loads and perform dependably in challenging environments.
- i. **Power Production and Distribution:** Synchronous generators, or induction machines, are utilized in power production facilities to transform mechanical energy into electrical energy. They help with the effective distribution and management of electrical power by being used in substations for voltage regulation and reactive power compensation.
- j. **Agriculture:** Induction machines are used in agriculture to power machinery such as grain handling equipment, irrigation systems, and other agricultural equipment. They operate with dependability and effectiveness, which helps to boost output and cut costs.

These are only a handful of the numerous applications that induction devices can be used for. They are a popular option for powering various systems and processes in a variety of industries thanks to their adaptability, dependability, and affordability.

**Advantages of Induction Machines:** There are a number of benefits that induction machines provide, which lead to their extensive use in numerous applications. These are a few of the main benefits of induction machines:

1. **Reliable and Robust:** Induction machines are renowned for these qualities. They don't contain any brushes or commutators that could wear out or need maintenance, thus their construction is straightforward and robust. This design element increases the machine's toughness and guarantees continuous use with little downtime.
2. **Cost-Effective:** When compared to other kinds of electrical devices, induction machines are more affordable. They are less expensive to produce, buy, and maintain because to their straightforward design and capacity for mass production. The lack of brushes and commutators also lowers maintenance expenses over the machine's lifetime.



3. **Great Efficiency:** Induction machines provide great levels of efficiency, particularly at increasing loads. The lack of brushes decreases energy losses and friction, which improves overall efficiency. Depending on the operating conditions and design refinements, efficiencies typically vary from 80% to 95%.
4. **Wide Range of Power Ratings:** Induction devices come in a wide range of power ratings, ranging from a few watts to several megawatts. Due to their adaptability, they are appropriate for a wide range of applications, including power production systems, industrial machines, and small appliances.
5. **Self-Starting and Self-Regulating:** Induction machines are naturally able to start without the aid of external devices or elaborate control systems. They also have a self-regulating nature, which means that depending on the load conditions, they automatically change their speed and torque. These features make the machine's operation and control simpler, which facilitates system integration.
6. **High Torque-to-Inertia Ratio:** Due to their high torque-to-inertia ratio, induction machines are capable of rapidly accelerating and decelerating loads. Conveyors, cranes, and hoists are a few examples of applications that can benefit from this capability because they frequently start, stop, and reverse.
7. **Good Overload Capability:** Induction machines can withstand brief overload circumstances without suffering serious performance loss or damage because to their good overload capability. In applications where there are intermittent high loads or brief power surges, this property is helpful.
8. **Voltage Fluctuations:** Induction machines are not very sensitive to voltage changes. The supply voltage can vary somewhat without having a substantial impact on their performance or efficiency. This quality qualifies them for use in areas with erratic power systems or where voltage swings are frequent.
9. **Low Noise and Vibration:** When operating, induction devices make only moderate amounts of noise and vibration. This qualifies them for uses including HVAC systems, home appliances, and office machinery where noise reduction and smooth performance are crucial.
10. **Compatibility with Variable Frequency Drives:** Induction machines can be readily controlled and run with variable frequency drives (VFDs) thanks to their compatibility. VFDs provide for accurate speed and torque control, which enhances system performance and energy economy. Induction machines are highly suited for applications requiring variable speed control, such as electric vehicles, pumps, and fans, thanks to their interoperability with VFDs. Induction machines are favored by many sectors because to these benefits, where their dependability, affordability, efficiency, and diversity satisfy the needs of numerous applications.

## CONCLUSION

Finally, specialization is essential for improving the effectiveness and performance of induction devices. Significant gains in machine operation and energy efficiency have been made possible through advances in rotor design, stator winding designs, and control techniques. The creation of specialized solutions for certain applications has also benefited from optimization approaches,

improving overall performance. With possible improvements in areas like problem detection and diagnosis, sophisticated control algorithms, and integration with renewable energy sources, the investigation of specialization has created new possibilities for the future of induction machines. The performance, dependability, and application range of induction machines will surely continue to improve as a result of ongoing research and development in specialty, making them an even more desirable option for a variety of industrial industries.

#### REFERENCES:

- [1] S. W. Chong and X. Ye, "Task 1," in *Developing Writing Skills for IELTS*, 2020. doi: 10.4324/9780429290169-17.
- [2] A. Gonzalez, G. Corsini, S. Lobos, D. Seelenfreund, and M. Tello, "Metabolic specialization and codon preference of lignocellulolytic genes in the white rot basidiomycete *ceriporiopsis subvermispora*," *Genes (Basel)*, 2020, doi: 10.3390/genes11101227.
- [3] P. Vateekul, M. Kubat, and K. Sarinnapakorn, "Hierarchical multi-label classification with SVMs: A case study in gene function prediction," *Intell. Data Anal.*, 2014, doi: 10.3233/IDA-140665.
- [4] J. Herbst, "A machine learning approach to workflow management," in *Lecture Notes in Computer Science (including subseries Lecture Notes in Artificial Intelligence and Lecture Notes in Bioinformatics)*, 2000. doi: 10.1007/3-540-45164-1\_19.
- [5] A. An and N. Cercone, "Rule quality measures for rule induction systems: Description and evaluation," *Comput. Intell.*, 2001, doi: 10.1111/0824-7935.00154.
- [6] G. Bolis, L. Di Pace, and F. Fabrocini, "A machine learning approach to computer-aided molecular design," *J. Comput. Aided. Mol. Des.*, 1991, doi: 10.1007/BF00135318.
- [7] O. Lezoray, D. Fournier, and H. Cardot, "Neural network induction graph for pattern recognition," *Neurocomputing*, 2004, doi: 10.1016/j.neucom.2003.10.010.
- [8] R. S. Michalski, "Inferential Theory of Learning as a Conceptual Basis for Multistrategy Learning," *Mach. Learn.*, 1993, doi: 10.1023/A:1022653218449.
- [9] V. Podgorelec, M. Šprogar, and S. Pohorec, "Evolutionary design of decision trees," *Wiley Interdiscip. Rev. Data Min. Knowl. Discov.*, 2013, doi: 10.1002/widm.1079.
- [10] E. Baksa-Varga and L. Kovács, "Modeling generalization and specialization with Extended Conceptual Graphs," in *Open Computer Science*, 2012. doi: 10.2478/s13537-012-0023-7.

## STUDY OF INDUCTION MOTORS: PRINCIPLE AND APPLICATIONS

**Mrs. Ramya\***

\*Assistant Professor

Department of Electrical And Electronics Engineering,  
Presidency University, Bangalore, INDIA  
Email Id-ramyak@presidencyuniversity.in

---

### ABSTRACT:

*Due to their durability, dependability, and affordability, induction motors are frequently employed in both industrial and domestic settings. The working theory, design, and performance traits of induction motors are highlighted in this chapter's overview. The stator, rotor, and air gap between them are the main parts of an induction motor that are covered in detail. Additionally, the numerous varieties of induction motors, including winding rotor and squirrel cage motors, are examined along with their unique benefits and drawbacks. The essential ideas of motor starting, speed control, and efficiency enhancement methods for induction motors are also covered in this chapter. The technology of induction motors is also addressed in terms of typical applications and emerging trends. Overall, this chapter provides a thorough explanation of the workings and uses of induction motors.*

**KEYWORDS:** *Induction Motor, Single-Phase Induction Motor, Slip-Ring Induction Motor, Three-Phase Induction Motor, Squirrel-Cage Induction Motor, Wound-Rotor Induction Motor.*

---

### INTRODUCTION

Due to its simplicity, dependability, and efficiency, induction motors are a type of electric motor that are frequently employed in a wide range of applications. They are frequently used in industrial equipment, home appliances, fans, pumps, and many other devices that need to convert mechanical energy. Electromagnetic induction is the fundamental idea behind induction motors. These motors are made up of a spinning component known as the rotor and a stationary component known as the stator. The rotor is made up of a collection of conducting bars or coils, whereas the stator is made up of a set of insulated windings arranged in a certain design. A revolving magnetic field is produced when an alternating current (AC) is applied to the stator windings. The conductors of the rotor generate a voltage and current as a result of this revolving magnetic field. An electromagnetic force is produced, which drives the rotor to revolve, as a result of the relative motion between the rotor conductors and the rotating magnetic field. An induction motor's rotor can be either a wound rotor or a squirrel cage rotor. The short-circuited conductive bars that make up the squirrel cage rotor resemble a cage for squirrels, hence the name.

On the other hand, the wound rotor has three-phase windings that are comparable to those in the stator. Due to its simplicity and durability, the squirrel cage rotor is the most popular design used in induction motors. Induced currents flow in the conductive bars as the rotor turns, producing magnetic fields that interact with the revolving magnetic field of the stator. The torque created by this reaction keeps the rotor turning. A few benefits of induction motors include their great

efficiency, durability, and comparatively inexpensive price. Additionally, they are self-starters, able to get going without help from others. They also have a lengthy operating life and need little maintenance. Induction motors, however, also have their limitations. Their speed is influenced by the power supply's frequency and the motor's number of poles. Compared to other motor types, such DC motors, they also have less options for speed control. Induction motors are widely utilized because of their simplicity, dependability, and efficiency in a variety of industries and applications. They are a necessary part of innumerable devices and systems because of their capacity to transform electrical energy into mechanical energy.

**Working Principle of Induction Motor:**An induction motor's operation is based on the idea of electromagnetic induction. It involves the interaction of the induced currents in the rotor with the revolving magnetic field produced by the stator. A magnetic field that alternates in direction and rotates at a synchronous speed is produced when an AC voltage is delivered to the stator windings. This rotational speed is governed by the frequency of the power source and the number of poles in the motor. The rotor experiences voltage and current as a result of this revolving magnetic field. The generated current moves through the short-circuited conductive bars in a squirrel cage rotor. Lenz's law states that the induced current generates a magnetic field of its own that interacts with the revolving magnetic field of the stator. Electromagnetic torque is a force that results from the interaction of the two magnetic fields. The rotor begins to rotate as a result of the electromagnetic torque and accelerates to a speed just below the synchronous speed.

Slip is the term for the discrepancy between the synchronous speed and the actual rotor speed. The slip enables the motor to constantly produce torque. More current and magnetic fields are generated in the rotor as a result of the relative motion between the rotating magnetic field and the rotor conductors as the rotor turns. These induced magnetic fields combine with the magnetic field of the stator to produce torque that keeps the rotor rotating. The stator and rotor do not need to be physically connected for the induction motor to work. The electromagnetic fields are used for the power transfer. Induction motors benefit from this property, which makes them more reliable and straightforward. It's crucial to remember that an induction motor's speed is influenced by the power supply's frequency and the number of poles in the motor. Although the speed control range is constrained in comparison to other motor types, the torque output can be changed by varying the voltage and frequency of the power source. The formation of a rotating magnetic field in the stator, the induction of currents in the rotor, and the interplay of these magnetic fields to provide the required torque for motor rotation make up the general working principle of an induction motor[1]–[3].

## DISCUSSION

**Construction of Induction Machine:**An induction machine, also known as an induction motor, is built from a number of essential parts that cooperate to make it work. Let's look at the design of a conventional three-phase squirrel cage induction motor shown in Figure 1, the most prevalent design utilized in a variety of applications.

1. **Stator:** The stator, which is the induction machine's stationary component, generates the rotating magnetic field. It consists of a laminated iron core with slots for the stator windings on the inner periphery. In order to create many poles, the stator windings, which are commonly constructed of copper or aluminum, are placed in a certain configuration. The intended speed and the motor's performance characteristics determine the number of poles.

2. **Rotor:** The induction machine's revolving component is known as the rotor. The rotor of a squirrel cage induction motor is made up of laminated iron cores that are stacked vertically to form a cylindrical shape. The iron core slots contain the rotor conductors, which are typically constructed of aluminum or copper bars. The bars are shorted at each end by conducting end rings, giving the device the appearance of a squirrel cage, hence the name squirrel cage rotor. Induced currents go through the rotor conductors, creating the rotor magnetic field and torque.
3. **Bearings:** The rotor shaft is supported by the bearings, which also enable smooth rotation. Typically, either ball bearings or sleeve bearings are used in induction devices. Sleeve bearings are simpler and less expensive, frequently used in less demanding applications, while ball bearings offer lower friction and higher precision, making them suited for high-performance applications.
4. **End Shields:** The end shields protect the stator and rotor and support the motor mechanically. They are firmly fastened to the stator frame and commonly made of steel or cast iron.
5. **Frame:** The exterior structure that connects all the components together is called the frame. It gives the motor's internal components mechanical strength and defense. Typically, cast iron, steel, or an alloy of aluminum is used to create the frame.
6. **Ventilation System:** Induction machines produce heat while they are operating, so a good ventilation system is necessary to keep the temperature of the motor within reasonable bounds. Through apertures in the frame and the employment of cooling fans, ventilation is made possible, helping to dissipate the heat produced by the motor.
7. **Terminal Box:** The terminal box, which is on the outside of the motor, is where the electrical connections are kept. It offers a practical location for attaching the motor to the power source and enables the connection of control components, including thermal overload relays and safety equipment.
8. **Insulation System:** The motor's electrical insulation between its many components must be maintained at all times. Short circuits are avoided, and electrical breakdown is guarded against. The stator windings, rotor conductors, and other important components are covered with insulating tapes, enamel, varnish, mica, and other materials.

The main parts of a conventional squirrel cage induction motor are as follows. Depending on the particular motor design and intended application, extra features and components like as cooling fins, vibration sensors, and noise reduction techniques may also be present. An induction machine's precise structure and design may change depending on elements including power rating, efficiency requirements, climatic conditions, and needs for a particular application.

**Performance Characteristics of Induction Motors:** An induction motor's operational efficiency and capability can be determined in large part by looking at its performance characteristics. An induction motor's main performance qualities include:

- a. **Efficiency:** The motor's efficiency is a metric for how well it transforms electrical power into mechanical power. Less energy is lost and operations are more productive with higher efficiency. Induction motors often operate at or close to their rated load with good efficiency.



- b. **Power Factor:** Power factor is a measurement of the motor's voltage and current's phase relationship. An improved use of electrical power is indicated by a greater power factor. With induction motors, the current typically follows the voltage with a lagging power factor. Power factor correction procedures can be used to increase power factor.
- c. **Starting and Pull-out Torque:** Starting torque and pull-out torque are two terms used to describe the highest torque that a motor may produce while still operating steadily. Starting torque is the torque produced by the motor during startup. Due to its ability to start under load, induction motors have a comparatively high beginning torque. However, as speed rises, their pull-out torque falls.
- d. **Speed Control:** Compared to other motor types like DC motors, induction motors have less precise speed control. The frequency of the power source and the number of poles affect an induction motor's speed. However, some speed control techniques, including variable frequency drives (VFDs), can be used to partially alter the motor speed.
- e. **Overload Capability:** An induction motor's capacity to withstand brief overloads without suffering harm is referred to as its overload capability. Induction motors are made to withstand brief periods of moderate overloading, such as those that occur during startup or unexpected load changes. Continuous operation under extreme overload risks overheating and motor damage.
- f. **Noise and Vibration:** Induction motors typically function with low noise levels of vibration. Some motors, however, could have higher noise and vibration levels as a result of things like an imbalanced rotor or poor attachment. Noise and vibration can be reduced with proper maintenance and balance.
- g. **Maintenance and Reliability:** Induction motors are renowned for their dependability and low maintenance needs. They are easy to maintain because of their straightforward construction, which excludes brushes and commutators. Long-term reliability is still dependent on regular maintenance, lubrication, and monitoring of motor performance.

The usefulness of an induction motor for particular applications is highly dependent on these performance features. To guarantee best performance and efficiency, these aspects must be taken into account while choosing and using an induction motor.

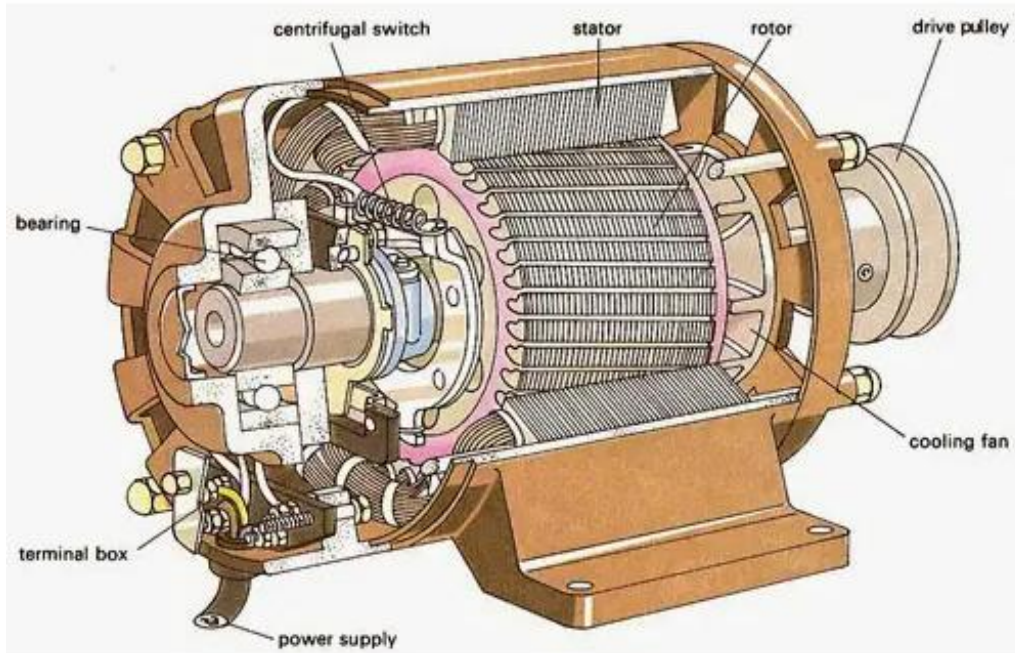

**Figure 1: Construction of Three Phase Induction Motor [StudyElectrical.**

**Single-phase Induction Motor:** In many situations where three-phase electricity is not easily accessible, single-phase induction motors are employed extensively. They are frequently found in commercial equipment, small industrial gear, and domestic appliances. These motors are renowned for their simplicity, affordability, and dependability. A single-phase induction motor operates on a similar fundamental tenet as a three-phase induction motor. To generate rotational motion, it depends on the interaction of a stationary rotor and a spinning magnetic field. A revolving magnetic field can be produced with a single-phase power supply; however, it only generates a pulsing magnetic field. Three major parts: a stator, a rotor, and a starting mechanism make up a single-phase induction motor. A laminated iron core and uniformly spaced windings make up the stator. The main winding and an auxiliary winding sometimes referred to as the starting winding are normally organized in two groups. While the auxiliary winding is linked in series with a beginning capacitor, the main winding is connected directly to the power source. The main winding of the motor produces a magnetic field that alternates in polarity when power is applied to it.

A phase shift between the magnetic field of the main winding and the rotor is simultaneously created by the auxiliary winding and beginning capacitor. A revolving magnetic field is produced by this phase shift, and this produces current in the rotor. A single-phase induction motor's rotor can be either a winding type or a squirrel cage type. The conductive bars and laminated iron cores that make up the squirrel cage rotor are short-circuited at both ends by conducting rings. The revolving magnetic field causes current to flow through the rotor bars, creating its own magnetic field in the process. This magnetic field interacts with the magnetic field of the stator to cause the rotor to rotate. With a wound rotor, the speed and torque characteristics of the motor can be adjusted by connecting the rotor windings to external resistors or rheostats. Due to the auxiliary winding and starting capacitor, single-phase induction motors can start on their own. The starting winding and capacitor establish a phase difference between the main winding and

the rotor when the motor is first started, which generates the necessary torque to start the motor. The starting winding and capacitor are normally cut off from the circuit by a centrifugal switch after the motor reaches a specified speed. Single-phase induction motors are generally effective, dependable, and adaptable machines utilized in a variety of applications. They are appropriate for a variety of residential, commercial, and light industrial usage because of their straightforward design and little maintenance needs.

**Starting of Single-phase Induction Motor:** In many situations where three-phase power is either unavailable or uneconomical, single-phase induction motors are frequently used. Due to the lack of a rotating magnetic field, single-phase induction motor starting procedures are different from those for three-phase induction motors. Single-phase induction motors can be started using a variety of techniques. The most typical ones consist of:

a. **Split-Phase Induction Motor:** This technique combines a starting winding and a centrifugal switch with the main winding. Electrically, the main winding is electrically farther away from the starting winding, resulting in a phase difference between the two windings. Once the motor has reached roughly 75% of its rated speed, the centrifugal switch disconnects the starting winding.

b. **Induction motor with a start capacitor:** This technique employs a start capacitor in addition to the primary winding. The phase shift produced by the start capacitor aids in the motor's starting. Approximately 75–80% of the motor's rated speed is reached before a centrifugal switch cuts the start capacitor off from the circuit.

c. **Induction motor with a capacitor-start and run capacitor:** This technique uses an induction motor with a capacitor-start and a run capacitor. The run capacitor adds a second phase shift while the motor is operating, increasing its efficiency. The start capacitor causes the initial phase shift.

d. **Permanent Split Capacitor (PSC) Induction Motor:** Using this technique, an auxiliary winding and a run capacitor are continually connected in series. The phase shift caused by the run capacitor allows the motor to turn on and run. Applications where the load torque is comparatively consistent frequently employ PSC motors.

These starting techniques provide the single-phase induction motor the phase shift it needs to run and produce a rotating magnetic field. When the motor reaches its rated speed, the starting device such as a centrifugal switch or capacitors is cut off from the circuit, and the motor just uses its primary winding to continue operating. It's crucial to remember that the choice of starting method is influenced by various elements, including the motor's size, the required torque, and the features of the particular application[4]–[6].

**Three Phase Induction Motor:** An electric motor type that is frequently utilized in numerous industrial applications is the three-phase induction motor. It may transform electrical energy into mechanical energy and functions on the basis of the electromagnetic induction principle. The operation, design, and uses of a three-phase induction motor will all be covered in this essay. A three-phase induction motor's operation relies on the interaction of the conductors of the rotor with the stator's revolving magnetic field. The stator and the rotor are the two major components of the motor. The stator is made up of a laminated core with slots that are evenly spaced out and

filled with three-phase windings. An AC source, typically a three-phase power supply, is connected to these windings.

A rotating magnetic field is produced when the stator windings receive three-phase power. The time-phased currents passing through the three windings create this spinning magnetic field. Due to electromagnetic induction, the revolving magnetic field causes voltages to be induced in the rotor windings, also referred to as rotor bars or conductors. These conductors are carried by the rotor's laminated iron cores. By shorting rings or bars at the ends of the rotor conductors, a closed circuit is created. The rotor conductors experience a voltage as the stator's revolving magnetic field passes by them. This induced voltage causes currents to flow through the conductors of the rotor in accordance with Faraday's law of electromagnetic induction. The torque produced by the interaction of the rotor currents and the revolving magnetic field causes the rotor to rotate. The relative speed differential between the revolving magnetic field and the rotor is what is referred to as the induction motor's slip in this phenomenon.

The motor may rotate and produce torque thanks to the slip. A three-phase induction motor is built from a variety of parts. To reduce energy losses from eddy currents, silicon steel sheets that have been laminated form the stator core. Copper or aluminum conductors are frequently used in the stator windings. The rotor may be of the squirrel cage type, in which case the rotor conductors are short-circuited, or it may be of the wound kind, in which case the rotor windings are coupled to outside resistances or slip rings for added control. Three-phase induction motors have a number of benefits, including straightforward and durable design, high reliability, little maintenance needs, and effective functioning. They are extensively utilized in industrial applications such as machine tools, pumps, compressors, fans, and conveyors. They are excellent for a variety of applications due to their versatility, adaptability to varied loads, and ability to function in hostile situations. A three-phase induction motor, in summary, is an essential part of many industrial systems. Its electromagnetic induction-based operating system facilitates the transformation of electrical energy into mechanical energy. The motor's structure and design enable efficient and dependable performance in a variety of applications. Three-phase induction motors' adaptability and extensive use have a substantial positive impact on the development of industrial processes and technology.

**Starting of Three Phase Induction Motor:** One of the following techniques is generally used to start three-phase induction motors:

- a. **Direct-On-Line (DOL) Starter:** Using this technique, the main contractor is closed, connecting the motor directly to the power source. When the motor starts, it pulls a lot of inrush current typically 5-7 times the rated current. For small and medium-sized motors where the inrush current does not significantly reduce the voltage or disrupt the power system, DOL starters are frequently employed.
- b. **Star-Delta Starter:** This technique is used to start larger motors with less beginning current and with less fluctuating voltage. Each phase of the motor is initially linked to a terminal on the starter in a "star" configuration. As a result, each winding receives a voltage that is 1/3 (or roughly 58%) of the line voltage. The motor is converted to a "delta" mode, where the windings are connected in series to the full line voltage, after a predetermined amount of time, often a few seconds. A contactor is used to switch the motor windings in order to go



from star to delta. The starting current is decreased by the star-delta starter to roughly one-third of the DOL starting current.

- c. **Starter with an autotransformer:** This approach is comparable to the star-delta starter but lowers the voltage provided to the motor windings during beginning. The autotransformer taps enable a smoother start and lower starting current by allowing for a range of voltage decrease. When the star-delta approach is unable to regulate the starting current of large motors sufficiently, autotransformer starters are frequently utilized. Three-phase induction motors are frequently started using these techniques, and the choice is made based on the size of the motor, the required starting torque, and the capacity of the power system.

**Types of Induction Motors:** Based on the type of rotor construction, there are basically two types of induction machines: squirrel cage induction machines and wound rotor induction machines. Let's investigate each kind in greater depth:

1. **Squirrel Cage Induction Motors:** The most prevalent and commonly utilized type of induction motor is the squirrel cage induction machine. They are appropriate for a variety of applications because to their straightforward and durable design. The term "squirrel cage" refers to the rotor's look, which is similar to a squirrel cage wheel. The rotor is made up of short-circuited conducting bars (often comprised of aluminum or copper) that are inserted into slots between laminated iron cores. Conducting end rings link the bars at both ends. A spinning magnetic field is created when an AC voltage is given to the stator windings. This rotating magnetic field causes currents to be created in the rotor bars. The magnetic field created by these induced currents in the rotor bars interacts with the revolving magnetic field of the stator to produce torque and cause the rotor to rotate. Machines with squirrel cage induction are renowned for their ease of use, affordability, strong starting torque, and toughness. However, their ability to control speed is rather limited.

Due to their durability, simplicity, and affordability, squirrel cage induction machines, sometimes known as induction motors, are widely employed in many different fields and applications. These electromagnetic electric motors have a stator and a rotor and work on the electromagnetic principle. The operation, design, benefits, and applications of squirrel cage induction devices will all be covered in this article. The interaction between the magnetic field generated by the stator and the induced currents in the rotor is the basis of the operation of a squirrel cage induction machine. A laminated iron core with slots that can hold the stator winding, which is normally a three-phase winding, makes up the stator. A rotating magnetic field is produced when the stator winding receives three-phase alternating electricity. Currents in the rotor conductors are generated by this revolving magnetic field and are short-circuited by the end rings to create a closed loop.

A squirrel cage induction machine's rotor is constructed of laminated iron cores with "squirrel cage" conductors, or conductive bars, placed evenly between them. These conductors are inserted into the rotor slots and are commonly constructed of copper or aluminum. The term comes from the fact that the conductors' configuration and form resemble a squirrel cage. A magnetic field that opposes the magnetic field of the stator is created when the rotating magnetic field interacts with the conductors of the rotor. The rotor rotates as a result of the interaction's torque. The ease of building of squirrel cage induction devices is one of their key benefits. The lack of slip rings and brushes, which are found in other types of motors, decreases the likelihood



of mechanical failure and removes the need for maintenance. Squirrel cage motors are extremely dependable and appropriate for continuous operation in challenging conditions because to their sturdy design. The versatility of squirrel cage induction machines to work at different speeds is another benefit.

The speed of the spinning magnetic field can be changed by varying the frequency of the supplied current, allowing for different motor speeds. Due of this characteristic, squirrel cage induction motors can be used in conveyors, pumps, and fans, among other devices that need to be able to control speed. The high starting torque of squirrel cage induction motors is well recognized for allowing them to start big loads. The differential in speed between the revolving magnetic field and the rotor allows for the creation of this beginning torque. The relative speed is high when the motor is first turned on, which causes a high starting torque. The torque reduces and reaches a steady-state value when the rotor nears its synchronous speed (the speed of the rotating magnetic field). Squirrel cage induction devices have a fairly high efficiency, often between 85% and 95%. They are more cost- and energy-effective because of this efficiency. Additionally, because squirrel cage motors have a high-power factor and use less reactive power, they increase the quality of the electricity and lower the load on the electrical grid.

A variety of businesses use squirrel cage induction machines. They are frequently employed in industrial processes where sturdy and dependable motors are needed, such as pumps, compressors, blowers, and conveyors. Due to its effectiveness and low maintenance needs, squirrel cage motors are also frequently employed in HVAC systems, refrigeration units, and domestic appliances. Squirrel cage motors are utilized in the automobile industry to power the traction and auxiliary systems in electric and hybrid vehicles. In summary, squirrel cage induction machines are flexible and often employed electric motors that work by interacting between the revolving magnetic field of the stator and the induced currents in the conductors of the rotor. They are appropriate for a wide variety of applications across numerous industries thanks to their simplicity, resilience, variable speed capability, high starting torque, and efficiency. Squirrel cage induction machines continue to be a key component of the technology that powers our contemporary world because to continual improvements in motor technology.

**2. Wound Rotor Induction Motors:** Compared to squirrel cage machines, wound rotor induction machines, sometimes referred to as slip ring induction machines or wound rotor motors, have a more intricate design. A laminated iron core with three-phase windings that resemble the stator windings make up the rotor. The winding ends of the rotor are carried out to external terminals using slip rings and brushes, unlike squirrel cage rotors. The rotor windings can be connected to extra external circuits or external resistance thanks to the slip rings. Greater control over the motor's performance is made possible by this feature, which also makes it possible to use features like variable speed and strong beginning torque. The torque and speed characteristics of the motor can be changed by adjusting the external resistance linked to the rotor windings. Applications requiring precise speed control, including big industrial drives, hoists, and elevators, frequently use wound rotor induction devices[7]–[9].

Due to its simplicity, dependability, and affordability, squirrel cage induction machines account for the bulk of induction machines used in a variety of applications. Typically, wound rotor induction machines are used in applications that call for sophisticated control capabilities and variable speed needs. The decision between the two types is influenced by a number of variables,

including the needs of the application, the required level of control, and cost concerns. When compared to squirrel cage induction motors, wound rotor induction motors also referred to as slip ring induction motors offer a few advantages and features. We shall examine the advantages, applications, and working theory of wound rotor induction devices in this article. A winding rotor induction machine operates on a similar concept as a squirrel cage induction machine.

Its stator and rotor, both of which are necessary for the motor to function, make up this component. Similar to other induction motors, the stator is made of a laminated iron core with slots for the stator winding. When supplied with alternating power, the stator winding typically a three-phase winding generates a revolving magnetic field. A wound rotor induction machine's rotor is distinct from a squirrel cage rotor. The rotor is made out of a three-phase winding with several coils and exterior terminals connected to slip rings rather than short-circuited conductive bars. These slip rings enable the connection of external resistors or other circuits to the rotor windings. The external resistors combine to provide an external resistance circuit that is programmable, allowing the torque and speed characteristics of the motor to be altered. The rotor windings experience a voltage when the motor is running because of the stator's revolving magnetic field. The rotor windings experience current flow as a result of this induced voltage. Slip rings and external resistors offer a way to regulate the rotor current and, as a result, the torque and speed of the motor.

The torque-speed characteristic of the motor can be changed by altering the resistance connected to the rotor windings. The capability of wound rotor induction devices to produce high beginning torque is one of its key benefits. The motor can generate a larger starting torque compared to squirrel cage induction machines by including external resistors in the rotor circuit. Due to this characteristic, wound rotor motors are appropriate for large pumps, crushers, and mills as well as other machinery that requires significant starting torque. The flexibility to modify speed control is another benefit of wound rotor induction machines. The torque-speed curve of the motor can be changed, enabling speed control over a broad range, by altering the resistance connected to the rotor windings. This qualifies wound rotor motors for uses including crane systems, winders, and conveyor belts where precise speed control is required. Additionally, wound rotor induction machines display favorable efficiency and power factor traits.

Although slightly less than squirrel cage motors, wound rotor motor efficiency can still be quite good. Additionally, by modifying the external resistance, the motor's power factor can be enhanced, lowering the need for reactive power from the power source. Numerous systems and businesses use wound rotor induction devices. They are frequently employed in sectors including mining, cement, and metal processing where changeable speed control and strong beginning torque are crucial. Elevators, escalators, and hoists are just a few examples of equipment that uses wound rotor motors for fine control over speed and torque. They are also used in systems that require soft starting to lessen the mechanical strain on the powered equipment. Compared to squirrel cage induction machines, wound rotor induction machines offer a number of advantages, including a high beginning torque and customizable speed control. They offer flexibility in a variety of applications due to its capacity to alter the torque-speed characteristics through external resistance. Despite having a little lower efficiency than squirrel cage motors, wound rotor induction machines are nonetheless very important in sectors where their unique qualities are needed.

**Applications of Induction Motors:** Due to their durability, dependability, and affordability, induction machines are used in a wide range of sectors. The following are some typical uses for induction machines:

- a. **Industrial Machinery:** Industrial machinery, including pumps, compressors, fans, conveyors, and machine tools, frequently uses induction machines. They are perfect for powering and managing a variety of industrial operations because of their capacity to withstand heavy loads, offer flexible speed control, and function in severe settings.
- b. **HVAC Systems:** Heating, ventilation, and air conditioning (HVAC) systems frequently use induction devices. They provide reliable and effective performance for the fans and blowers that are used in buildings to circulate air and control temperature.
- c. **Electric Vehicles:** The propulsion systems of electric vehicles (EVs) utilise induction machinery. They supply the required torque and speed management for dependable and efficient vehicle operation. Due to their benefits including high power density, regenerative braking, and reliable performance, induction machines are appropriate for EV applications.
- d. **Renewable Energy Systems:** Induction machines are crucial components of renewable energy sources, especially in wind turbines and hydropower generators. They transform water or wind energy's mechanical energy into electrical energy. Due to its versatility in managing varying loads and speeds, induction machines are ideal for capturing renewable energy sources.
- e. **Household Appliances:** Appliances used in the home include washing machines, refrigerators, air conditioners, and dishwashers. These appliances use induction technology. They contribute to the overall energy efficiency and performance of these appliances by ensuring efficient and dependable functioning [10].
- f. **Treatment of Water and Wastewater:** Pumps, mixers, and aerators are frequently powered by induction motors in water and wastewater treatment facilities. They ensure effective water and wastewater treatment by providing dependable operation, ruggedness, and the capacity to manage a range of flow rates and loads.
- g. **Oil and Gas Sector:** Drilling rigs, compressors, pumping systems, and other equipment all make use of induction machines in the oil and gas sector. They are ideal for the rigorous requirements of the industry due to their dependability, resilience, and capacity to function in difficult settings.
- h. **Mining Operations:** Conveyor systems, crushers, and grinding mills are just a few of the applications for which induction machines are used in mining. They are ideal for mining operations due to their capacity to manage big loads and perform dependably in challenging environments.
- i. **Power Production and Distribution:** Synchronous generators, or induction machines, are utilized in power production facilities to transform mechanical energy into electrical energy. They help with the effective distribution and management of electrical power by being used in substations for voltage regulation and reactive power compensation.

- j. **Agriculture:** Induction machines are used in agriculture to power machinery such as grain handling equipment, irrigation systems, and other agricultural equipment. They operate with dependability and effectiveness, which helps to boost output and cut costs.

These are only a handful of the numerous applications that induction devices can be used for. They are a popular option for powering various systems and processes in a variety of industries thanks to their adaptability, dependability, and affordability.

**Advantages of Induction Motors:** There are a number of benefits that induction machines provide, which lead to their extensive use in numerous applications. These are a few of the main benefits of induction machines:

1. **Reliable and Robust:** Induction machines are renowned for these qualities. They don't contain any brushes or commutators that could wear out or need maintenance, thus their construction is straightforward and robust. This design element increases the machine's toughness and guarantees continuous use with little downtime.
2. **Cost-Effective:** When compared to other kinds of electrical devices, induction machines are more affordable. They are less expensive to produce, buy, and maintain because to their straightforward design and capacity for mass production. The lack of brushes and commutators also lowers maintenance expenses over the machine's lifetime.
3. **Great Efficiency:** Induction machines provide great levels of efficiency, particularly at increasing loads. The lack of brushes decreases energy losses and friction, which improves overall efficiency. Depending on the operating conditions and design refinements, efficiencies typically vary from 80% to 95%.
4. **Wide Range of Power Ratings:** Induction devices come in a wide range of power ratings, ranging from a few watts to several megawatts. Due to their adaptability, they are appropriate for a wide range of applications, including power production systems, industrial machines, and small appliances.
5. **Self-Starting and Self-Regulating:** Induction machines are naturally able to start without the aid of external devices or elaborate control systems. They also have a self-regulating nature, which means that depending on the load conditions, they automatically change their speed and torque. These features make the machine's operation and control simpler, which facilitates system integration.
6. **High Torque-to-Inertia Ratio:** Due to their high torque-to-inertia ratio, induction machines are capable of rapidly accelerating and decelerating loads. Conveyors, cranes, and hoists are a few examples of applications that can benefit from this capability because they frequently start, stop, and reverse.
7. **Good Overload Capability:** Induction machines can withstand brief overload circumstances without suffering serious performance loss or damage because to their good overload capability. In applications where there are intermittent high loads or brief power surges, this property is helpful.
8. **Voltage Fluctuations:** Induction machines are not very sensitive to voltage changes. The supply voltage can vary somewhat without having a substantial impact on their performance

or efficiency. This quality qualifies them for use in areas with erratic power systems or where voltage swings are frequent.

9. **Low Noise and Vibration:** When operating, induction devices make only moderate amounts of noise and vibration. This qualifies them for uses including HVAC systems, home appliances, and office machinery where noise reduction and smooth performance are crucial.
10. **Compatibility with Variable Frequency Drives:** Induction machines can be readily controlled and run with variable frequency drives (VFDs) thanks to their compatibility. VFDs provide for accurate speed and torque control, which enhances system performance and energy economy. Induction machines are highly suited for applications requiring variable speed control, such as electric vehicles, pumps, and fans, thanks to their interoperability with VFDs.

Induction machines are favored by many sectors because to these benefits, where their dependability, affordability, efficiency, and diversity satisfy the needs of numerous applications.

**Slip-Ring Induction Motor:** A common type of electric motor used in many industrial and commercial applications is the induction motor. It functions according to the electromagnetic induction principle, which transforms electrical energy into mechanical energy to power spinning gear. The stator, which has an insulated wire winding and a laminated core, is the essential component of an induction motor. A revolving magnetic field is produced when the stator windings are coupled to an alternating current (AC) power source. The rotor, an essential part of the motor, experiences voltage as a result of this rotating magnetic field. The two different types of rotors are squirrel cage rotors and wrapped rotors. The most typical and straightforward type is the squirrel cage rotor. It is made up of conductive bars parallel to the rotor's axis and laminated iron cores. The term comes from the way the bars are short-circuited at the ends by conductive end rings, giving the appearance of a squirrel cage. The squirrel cage rotor interacts with the stator's revolving magnetic field to induce current in the bars, which generates a second magnetic field.

The two magnetic fields' interaction produces torque, which moves the rotor around. The wound rotor, on the other hand, is built differently. It has a laminated core with slots that are filled with insulated wire windings. The ends of the windings are exposed and attached to rotor rheostats or external resistors with variable resistance. Through a series of slip rings and brushes, the stator windings and the rotor windings are joined. These slip rings allow the rotor windings to revolve and connect to external electrical sources. The features of the motor, such as starting torque and speed control, can be changed by adjusting the resistance in the rotor circuit. The slip rings, which are installed on the rotor shaft, give the rotor windings an ongoing electrical connection. They are normally isolated from the rotor shaft and composed of high-conductivity materials like copper or bronze. The passage of electrical current between the rotating component (rotor) and the stationary component (stator) is ensured by carbon brushes in contact with the slip rings.

A revolving magnetic field is created when an AC voltage is delivered to the stator windings, which is a brief summary of how an induction motor works. Through the slip rings, this magnetic field creates voltage in the rotor windings. The magnetic field produced by the induced voltage interacts with the magnetic field of the stator because it causes current to flow in the rotor windings. The two magnetic fields interact to create a torque that propels the rotor into rotation. The rotor revolves at a speed that is somewhat slower than the stator's revolving



magnetic field. Slip is a percentage-based term used to describe this speed disparity. The motor load, rotor resistance, and the number of poles all have an impact on the slip, which is required for the creation of torque. The reliability, resilience, and simplicity of induction motors are well known. They are extensively utilized in numerous systems, including pumps, fans, compressors, conveyors, and many more.

The lack of brushes and commutators, which are present in other motor types, reduces wear and tear and removes the need for routine maintenance. The electromagnetic induction principle underlies the operation of induction motors, which are versatile and frequently used electric motors. It depends on the interplay of the induced magnetic field in the rotor and the stator's revolving magnetic field. A wound rotor induction motor's slip rings and brushes enable external electrical connections and motor characteristic control. Because of their versatility, dependability, and ease of use, induction motors are popular.

## CONCLUSION

Induction motors, which provide a number of benefits like simplicity, robustness, and cost-effectiveness, are crucial in many industrial and domestic contexts. Their electromagnetic induction-based operating concept enables the transformation of electrical energy into mechanical energy. Induction motors are built with a stator and rotor separated by an air gap, which allows for effective power transfer and dependable operation. Induction motors come in a variety of designs, including winding rotor and squirrel cage motors, which offer versatility in terms of performance and uses. Smooth and controlled acceleration is ensured by motor starting techniques like direct-on-line starting and reduced voltage starting methods. Pole changing arrangements and variable frequency drives are two speed control techniques that allow for exact motor speed adjustment to meet application-specific needs. Energy savings and lower running costs are made possible by efficiency enhancement approaches, such as the adoption of high-efficiency motor designs and power factor correction.

## REFERENCES:

- [1] T. D. Lopes, A. Raizer, and W. V. Júnior, "The use of digital twins in finite element for the study of induction motors faults," *Sensors*, 2021, doi: 10.3390/s21237833.
- [2] K. Wang, R. Huai, Z. Yu, X. Zhang, F. Li, and L. Zhang, "Comparison study of induction motor models considering iron loss for electric drives," *Energies*, 2019, doi: 10.3390/en12030503.
- [3] V. Goman, V. Prakht, V. Kazakbaev, and V. Dmitrievskii, "Comparative study of induction motors of IE2, IE3 and IE4 efficiency classes in pump applications taking into account CO2 emission intensity," *Appl. Sci.*, 2020, doi: 10.3390/app10238536.
- [4] O. AlShorman *et al.*, "Sounds and acoustic emission-based early fault diagnosis of induction motor: A review study," *Advances in Mechanical Engineering*. 2021. doi: 10.1177/1687814021996915.
- [5] P. Lumyong and P. Sarikprueck, "A Study on Induction Motor Efficiency Improvement for Implementing in Electric Vehicle," in *ICEMS 2018 - 2018 21st International Conference on Electrical Machines and Systems*, 2018. doi: 10.23919/ICEMS.2018.8549478.

- [6] M. Ghaseminezhad, A. Doroudi, S. H. Hosseinian, and A. Jalilian, "Analytical field study on induction motors under fluctuated voltages," *Iran. J. Electr. Electron. Eng.*, 2020, doi: 10.22068/IJEEE.17.1.1620.
- [7] A. Gugaliya, S. Boral, and V. N. A. Naikan, "A hybrid decision making framework for modified failure mode effects and criticality analysis: A case study on process plant induction motors," *Int. J. Qual. Reliab. Manag.*, 2019, doi: 10.1108/IJQRM-08-2018-0213.
- [8] A. Herawati, M. A. Saputra, and I. N. Anggraini, "Analisis Pengaruh Sudut Penyalaan TRIAC terhadap Pengaturan Kecepatan Motor Induksi Satu Fasa Menggunakan Cycloconverter," *J. Amplif. J. Ilm. Bid. Tek. ELEKTRO DAN Komput.*, 2021, doi: 10.33369/jamplifier.v11i1.15766.
- [9] A. Rasyadan, S. bin Yaacob, P. Krishnan, M. Rizon, and C. K. Ang, "Simulation of SPWM fed three-phase induction motor drive mathematical model using MATLAB simulink," *J. Robot. Netw. Artif. Life*, 2020, doi: 10.2991/jrnal.k.200909.006.
- [10] O. Çetin, A. Dalcalı, and F. Temurtaş, "A comparative study on parameters estimation of squirrel cage induction motors using neural networks with unmemorized training," *Eng. Sci. Technol. an Int. J.*, 2020, doi: 10.1016/j.jestch.2020.03.011.

## STARTING AND SPEED CONTROL OF THREE-PHASE INDUCTION MOTOR

**Mrs. Ragasudha Chundampunathil\***

\*Assistant Professor,  
Department of Electrical And Electronics Engineering,  
Presidency University, Bangalore, INDIA  
Email Id-ragasudha@presidencyuniversity.in

### ABSTRACT:

*One of the most popular types of electric motors in numerous industrial applications is the three-phase induction motor. This motor offers great efficiency and reliable performance because to its electromagnetic induction-based operation. The starting and speed control strategies used in three-phase induction motors are the main topics of this chapter. It examines the many techniques employed to turn on the motor and sustain accurate speed control while it is operating. The main conclusions and findings from the study are outlined in the chapter.*

**KEYWORDS:** *Auto-Transformer Starter, Direct-On-Line Starter, Direct Torque Control, Field Oriented Control, Starter, Soft Starter, Star-Delta Starter, Vvzf, Variable Frequency Drive.*

### INTRODUCTION

A three-phase induction motor must be started and its speed must be controlled. Due to its durability, simplicity, and dependability, induction motors are frequently utilized in a variety of industrial applications. This type of motor is used in a variety of devices, including pumps, compressors, fans, and conveyor systems. Effective starting approaches and speed control strategies are used to ensure efficient functioning and the motor's protection. The introduction of starting and speed control techniques for three-phase induction motors will be covered in this essay. A three-phase induction motor's starting process is crucial because it must overcome the rotor's inertia and provide enough torque to accelerate. The simplest way to start a motor is by connecting it directly to the power source, which is known as direct-on-line (DOL) beginning. However, DOL starting generates a large inrush current that can lead to voltage drops and power system disruptions.

Alternative starting techniques are therefore used to address these problems. The star-delta starter is a common starting technique. In order to reduce the starting current, it includes initially connecting the motor in a star configuration. The motor is shifted to a delta arrangement for regular operation once it reaches a particular speed. Although the star-delta starter has a restricted starting torque, it is effective at reducing the starting current. The auto transformer starter is yet another starting technique. It lowers the voltage provided to the motor while starting by using an auto transformer. The beginning current can be adjusted, resulting in a smooth and steady acceleration of the motor, by tapping the transformer at various voltage levels. Compared to the star-delta approach, the auto transformer starter offers superior starting torque, but it has restrictions on the highest starting torque that can be achieved. Additionally, electronic soft starts are becoming more and more well-liked. These starters use silicon-controlled rectifiers (SCRs)

or thyristors as power electronic components to regulate the voltage and current provided to the motor during starting. With adjustable starting torque, they allow precise control over the starting process and smooth acceleration.

Additionally, electronic soft starts include features like improved motor diagnostics and overload protection[1]–[3]. Speed control becomes essential in many applications once the motor has effectively started. A three-phase induction motor's speed can be controlled using a variety of techniques. Voltage regulation is one such technique. The supplied voltage to the motor can be changed to alter its speed. This approach has drawbacks because it reduces the motor's torque and effectiveness. As a result, it works best for applications that don't need precise speed control. Stator voltage control is another widely used speed control technique. The magnetic field created in the motor can be altered, changing the speed, by altering the voltage delivered to the stator windings. This approach can result in a reduction in torque at low speeds but offers strong speed control across a broad range. Another efficient strategy for speed control is frequency control. The motor's synchronous speed can be altered, which will alter the motor's real speed, by altering the power supply's frequency. Variable frequency drives (VFDs) or inverters are frequently used to control frequency.

They provide precise adjustment of the motor's speed and torque by converting the fixed-frequency AC power source into variable-frequency AC power. Additionally, speed control can be achieved by using rotor resistance control. The rotor circuit's external resistance can be added to modify the speed of the motor by adjusting the slip. In contrast to the methods previously discussed, this one is less effective and less widely employed. Induction motors that operate in three phases must start and be controlled at a specific speed. Direct-on-line, star-delta, auto transformer, and electronic soft starters are just a few of the beginning techniques used to provide controlled and smooth motor acceleration while reducing the impact on the power system. Voltage control, stator voltage control, frequency control with VFDs or inverters, and rotor resistance control are all examples of speed control techniques. Every approach has benefits and drawbacks, and the best option will depend on the requirements of the individual application. Three-phase induction motors may be efficiently run, which improves their performance and lengthens their lifespan, with the right starting and speed control procedures.

**Starting techniques of Three Phase Induction Motor:** Three-phase induction motors can be started using a variety of methods. These methods aim to minimize the effect on the power system while ensuring a smooth and regulated start. Let's look at some of the most common ways to start:

- a. **Direct-On-Line (DOL) Starting:** This is the easiest and most direct means of starting. This method applies full voltage across the motor windings by connecting the motor directly to the power source. Due to the significant inrush current that arises during the startup phase, the power system may experience voltage dips and other issues. When the power source is capable of handling the inrush current and the motor is small with low starting torque requirements, DOL starting is appropriate.
- b. **Star-Delta Starting:** Wye-Delta Starting is another name for star-delta starting, which is a common technique for medium-sized to large induction motors. It includes limiting the starting current by first connecting the motor windings in a star configuration during the starting period. The motor is shifted to a delta configuration for routine operation once it

achieves a specific speed (usually between 70 and 80 percent of the rated speed). Star-delta starting has a lower beginning current requirement but a lower starting torque.

- c. **Auto Transformer Starting:** The auto transformer starting technique lowers the voltage provided to the motor during starting by use of an auto transformer. The beginning current can be adjusted, resulting in a smooth and steady acceleration of the motor, by tapping the transformer at various voltage levels. When opposed to the star-delta approach, auto transformer starting offers more starting torque. Regarding the highest beginning torque that can be achieved, it is however constrained.
- d. **Reactor Starting:** When starting a reactor, a motor is connected in series with an external reactor. The reactor restricts the motor's starting current and lowers the voltage that is provided to it. This approach is less popular but may be appropriate for situations that call for a gradual start and a lower inrush current. Reactor starting has larger losses and costs than DOL beginning but offers better torque control.
- e. **Electronic Soft starts:** Electronic soft starts regulate the voltage and current provided to the motor while beginning using power electronic components like thyristors or silicon-controlled rectifiers (SCRs). They give the beginning process a precise level of control, enabling customizable starting torque and smooth acceleration. Additionally, electronic soft starts include features like improved motor diagnostics and overload protection. In situations where a regulated start and less mechanical stress on the motor are desirable, they are frequently used. These are a few of the methods for starting three-phase induction motors that are frequently employed. Various considerations, including motor size, required torque, power system limitations, and requirements for a particular application, influence the starting technique choice. To ensure effective and consistent motor starting, the best methodology must be chosen for the specific motor and application at hand. Each technique has its benefits and drawbacks.

## DISCUSSION

**Starter:** A starter is a device or mechanism used in power systems to start and regulate the functioning of electric motors or other high-power electrical machinery. It aids in supplying the necessary current, voltage, and control signals needed to smoothly start and accelerate the motor or other piece of machinery. A starter's main job is to manage the significant inrush current that happens when a motor starts up. An electric motor consumes a large amount of current when it first turns on. This current can be several times more than the motor's typical operating current. This high current may result in voltage dips, motor overheating, and winding damage. By regulating the current flow and gradually raising the voltage provided to the motor, the starter aids in resolving these problems. Depending on the size, function, and control needs of the motor, different types of starters are employed in power systems. Several popular starts include:

- a. **Direct-On-Line (DOL) Starter:** The most basic and typical starter used for tiny motors is the direct-on-line (DOL) starter. It establishes a direct connection between the motor and the power source, enabling the motor to get the entire voltage when starting. Electric motors are started and controlled by a Direct-On-Line (DOL) starter, a form of motor starting used in electrical systems. It is the most straightforward and typical way to start an induction motor. During the starting procedure, the DOL starter maintains a complete line voltage connection with the power supply. This indicates that the motor starts abruptly because it obtains the entire voltage and torque when



the starter is turned on. When starting current is not an issue or the motor load is low, the DOL starter is commonly utilized for small- to medium-sized motors. A contactor, an overload relay, and a start button make up the DOL starter. The contactor closes when the start button is depressed, allowing the entire supply voltage to reach the motor. The motor is shielded from excessive current by the overload relay.

The overload relay will trip and disconnect the motor from the power supply if the current exceeds a predetermined limit, protecting the motor from harm. The simplicity of the DOL starter is one of its key benefits. It takes little wiring and is simple to install. It does, however, have some restrictions. High inrush currents can come from the abrupt application of full voltage to the motor, which could be because of voltage dips in the power supply system and mechanical strain on the motor windings. This can be a problem if the power supply system is underpowered or if the motors are larger. Other motor starter types, like star-delta starters or soft starters, are frequently utilized to reduce the high starting current. To lessen the inrush current and give the motor a smoother start, these starters lower the voltage or gradually raise it while the motor is starting.

**b. Star-Delta Starter:** The Star-Delta Starter is a starter that is utilized with larger motors. The motor windings are first connected in a star pattern, which lowers the voltage applied to the motor during startup. It shifts the windings to a delta arrangement after a given amount of time or speed, enabling the motor to run at full voltage. When starting electric motors, a Star-Delta starter is utilized to lessen the inrush current and beginning torque. It is frequently used for motors that are medium to large in size. With its unique motor winding structure, the Star-Delta starter can operate in either the Star mode or the Delta mode, which are two separate operating modes. The motor windings are coupled in a star (or wye) form while in the star mode. By decreasing the voltage delivered to each winding, the beginning current and torque are decreased. The starter shifts to the delta mode when the motor reaches a particular speed, which causes the windings to be rearranged into a delta (or mesh) configuration.

The motor operates in this mode with its maximum voltage and torque. Typically, a contactor, a timer, and a control circuit make up a Star-Delta starter. The contactor first connects the motor windings in a star configuration when the starter is turned on, enabling the motor to start with less current. The contactor shifts the windings to the delta configuration after a predetermined amount of time, giving the motor its full voltage and torque. The motor must be given time to accelerate and attain an appropriate speed before the greater voltage is delivered during the change from star to delta configuration. The length of this delay may typically be adjusted and is determined by the load needs and characteristics of the motor. A gradual transition is ensured by the timer, which also prevents unexpected voltage and torque fluctuations that can harm the motor or other connected equipment.

Comparing the Star-Delta starter to the Direct-On-Line (DOL) starter, there are a number of benefits. It avoids voltage dips and prevents undue mechanical stress on the motor during starting by lowering the starting current. It is especially helpful for motors that need a lot of starting torque or when the power supply system has a lot of limitations. It's crucial to keep in mind, though, that the Star-Delta starter requires more wiring and a complicated control circuit than the DOL starter. The installation is more expensive and complex because of the timer and control components. Additionally, the motor briefly loses torque while switching from star to

delta mode, which could have an impact on some applications. The Star-Delta starter is a common option for medium- to large-sized motors when a smooth and controlled start is sought because it achieves a balance between lowering the beginning current and giving enough torque for motor operation[4]–[6].

c. **Auto-Transformer Starter:** Similar to a star-delta starting, the auto-transformer starter employs an auto-transformer to lower the voltage provided to the motor during startup. However, a tap on the transformer winding is used to reduce the voltage. When starting a motor, the beginning current and voltage are reduced by using an auto-transformer starter (ATS). It frequently serves as a motor for medium- to large-sized motors. In order to supply a variable voltage to the motor during starting, the autotransformer starter uses an autotransformer, which is a single winding transformer with numerous taps. The voltage delivered to the motor can be changed by tapping various locations along the winding, which lowers the beginning current and torque. An autotransformer, a contactor, and a control circuit normally make up an autotransformer starter. The contactor shuts when the starter is turned on, joining the motor to the autotransformer.

Depending on the desired voltage decrease, the control circuit adjusts the position of the tap on the autotransformer. The autotransformer first applies a lower voltage to the motor during beginning, which lowers the starting current and torque. The tap on the autotransformer is gradually shifted to apply a higher voltage when the motor accelerates and reaches a particular speed, delivering full voltage and torque for typical operation. Similar to the Star-Delta starter, the Auto-Transformer starter has advantages in terms of lower starting current and torque. It lessens the mechanical stress placed on the motor during startup and helps to reduce voltage drop in the power supply system. When the power supply system is underpowered or has a large inertia load on the motor, it is especially helpful.

The Auto-Transformer starter delivers a more progressive and regulated voltage transfer than the Star-Delta starter. In order to provide a smoother acceleration, the autotransformer enables constant modification of the voltage provided to the motor. Applications that need for precise control during motor initiation may find this useful. The Auto-Transformer starter does have certain restrictions, though. The autotransformer is one of the extra parts needed, which raises the price and complexity of the system. Careful consideration must be given to the control circuit's design to guarantee correct voltage regulation and transition. The autotransformer's structure could also result in some energy losses. In general, the Auto-Transformer starter is a practical choice for lowering the starting torque and current of medium- to large-sized motors. In order to facilitate smoother operation and lessen strain on the motor and power supply system, it offers a regulated and adjustable voltage reduction during startup.

d. **Soft Starter:** A soft starter provides a regulated and smooth startup by gradually raising the voltage provided to the motor. The high inrush current is eliminated by using solid-state electronics to manage the voltage and current. An electric motor starter known as a "soft starter" is used to start and control the acceleration of electric motors gradually. It is intended to provide a smoother and more regulated motor running by reducing the inrush current and mechanical stress during beginning. Instead of applying full voltage to the motor at beginning like Direct-On-Line (DOL) starters or Star-Delta starters do, a Soft Starter uses solid-state components like

thyristors or silicon-controlled rectifiers (SCRs) to raise the voltage and torque provided to the motor gradually.

Power semiconductor components that are coupled in series with the motor's power supply lines make up the Soft Starter. By adjusting the thyristors' firing angles, these devices regulate the voltage and current fed to the motor. A control circuit is also a part of the Soft Starter, and it keeps track of the motor's parameters and modifies the voltage as necessary. The Soft Starter starts the motor with a low voltage and gradually raises it over a predetermined period of time. The motor windings and other associated equipment experience less electrical and mechanical stress as a result of the slow voltage ramp-up, which controls the inrush current. Customizable acceleration profiles offered by the Soft Starter make it possible to fine-tune the motor's performance in accordance with the demands of the application. Soft starters have a number of benefits. They avoid voltage dips and lessen the need to oversize the electrical system by restricting the initial current. As a result, there are energy savings, longer motor lifespans, and less mechanical component wear and tear.

In addition to offering fine control over acceleration and deceleration, soft starters also make operation more comfortable and reduce shock loads. Soft Starters can also provide other functions including motor protection, fault detection, and interfaces for integrating with control systems. Phase loss detection, motor braking, and motor overload protection may all be included into some sophisticated models. Notably, soft starters are typically appropriate for a variety of motor sizes and uses, such as pumps, fans, compressors, and conveyor systems. However, they are frequently employed with motors that don't need a lot of beginning torque or when a controlled and progressive start is preferred. Soft Starters reduce the starting current and mechanical stress by enabling a regulated and gradual startup for electric motors. They provide enhanced effectiveness, motor safety features, and fine control over acceleration and deceleration. To improve the performance and dependability of motors, soft starters are frequently employed in a variety of industrial and commercial applications.

**e. Variable Frequency Drive (VFD):** Variable Frequency Drive (VFD): A VFD, also referred to as an adjustable speed drive, controls the motor's speed and torque in addition to starting it. This is done by changing the voltage and frequency that are provided to the motor, which allows for exact control of motor performance. An electronic device used to control the speed and torque of electric motors by adjusting the frequency and voltage of the power supplied to the motor is referred to as a variable frequency drive (VFD), also known as an adjustable speed drive (ASD) or an inverter drive. It is frequently used in commercial and industrial applications to increase motor performance, save energy, and control precisely. The entering fixed-frequency AC power is changed into a variable-frequency output by the VFD in order to operate. An inverter, a DC bus, and a rectifier make up its three primary parts. DC electricity is then stored on the DC bus after being converted from AC power by the rectifier. The inverter changes the DC electricity back into controllable AC power with a changeable frequency and voltage. The output frequency and voltage of the VFD can be changed to regulate the motor's speed and torque in accordance with the demands of the application. This enables the motor to run at its highest efficiency level and provides for a wide range of speed control, from extremely low speeds to high speeds.

**Speed control Techniques:** A three-phase induction motor's ability to control speed is essential for industrial applications that call for variable speed operation. One can reduce energy

consumption, improve process effectiveness, and exert exact control over machines by adjusting the motor's speed. There are various techniques used to manage speed, and each has benefits and drawbacks. This post will examine various methods for controlling the speed of a three-phase induction motor. Understanding a three-phase induction motor's fundamental operating principle is crucial before exploring speed control techniques. It consists of a stator with three-phase windings that are powered by an AC power source, and either a wound or squirrel cage type of rotor. The stator windings conduct three-phase currents, which produce a rotating magnetic field. This magnetic field's rotation creates currents in the rotor, which produces a torque that powers the motor.

Changing the number of poles in the motor is one of the simplest ways to alter speed. This method can be used with motors that have coiled rotors. The number of poles can be altered by adjusting the connections in the rotor windings, which will also modify the synchronous speed of the motor. Due to the physical adjustments that must be made to the motor and the consequently constrained speed ranges, this approach is not appropriate for the majority of applications. Voltage control is another extensively used speed control technique. The magnetic field intensity and speed of the motor can both be changed by adjusting the supplied voltage to the motor. Usually, either an autotransformer or a variable voltage inverter is used to perform this strategy. Voltage regulation can reduce torque at low speeds and result in inefficient motor operation, despite being straightforward and inexpensive. Another widely used strategy for speed control is frequency control.

The power supply's frequency can be changed while the voltage is kept constant to alter the motor's speed. Inverters or variable frequency drives (VFDs) are used to implement this technique. VFDs create variable frequency AC output to control the motor speed after converting the AC source to DC. A wide speed range, good torque control, and high efficiency are all features of frequency control. For speed control applications, pulse width modulation (PWM) approaches have grown in favor recently. PWM includes quickly turning on and off the motor's power source. This effectively controls the average voltage and, in turn, the speed. Insulated gate bipolar transistors (IGBTs), a type of power electronic device, are frequently used to perform this method. PWM can enhance efficiency, minimize harmonics, and give precise control, but it can also introduce high-frequency noise and call for intricate control algorithms. Field-oriented control, or vector control, is a sophisticated speed control technique that provides exceptional performance and dynamic response.

It entails separating the stator current into the magnetizing current and the torque-producing current. These two elements can be independently controlled to accurately control the motor's speed and torque. To obtain accurate control, vector control needs complex algorithms and input from motor sensors like encoders or resolvers. Other specialized approaches are utilized for speed control in particular applications in addition to the aforementioned ones. These include senseless control, slip energy recovery systems, and direct torque control (DTC). Fast torque and flux control is provided by DTC without the use of intricate coordinate transformations. To recover and transfer energy back to the power source during speed regulation, SERS makes use of additional circuits. By calculating rotor position and speed with the help of algorithms and motor measurements, sensor less control systems do away with the requirement for external sensors. A three-phase induction motor's speed regulation is essential for reaching peak performance in a variety of industrial applications. There are numerous approaches, each with

benefits and drawbacks. The desired speed range, required torque, efficiency factors, and budgetary restrictions all play a role in the choice of speed control mechanism. Modern industrial systems can now have improved energy efficiency and performance thanks to engineers' and researchers' ongoing exploration of new technologies and algorithms to increase motor control approaches[7]–[9].

**Type of Speed Control Techniques:** Three-phase induction motors can be controlled at different speeds using a variety of methods. Some of the frequently used techniques are listed below:

- a. **Voltage Control:** This technique includes changing the motor's power supply voltage. The motor's speed can be altered by changing the voltage; conversely, it can be raised by decreasing the voltage. Voltage management, however, may have an impact on the motor's efficiency and torque-speed characteristics.
- b. **Frequency Control:** Controlling the power supply's frequency while keeping the voltage constant is known as frequency control. The speed of the motor can be altered by altering the frequency, and the opposite is true for the other way around. Variable frequency drives (VFDs) or inverters are frequently used to control frequency.
- c. **Pole Changing:** Motors with wrapped rotor structure can use this technique. The number of poles can be altered by changing the connections in the rotor windings, which will also alter the motor's synchronous speed and, in turn, its operating speed. However, pole change is usually restricted to a few distinct speed steps and necessitates physical adjustments to the motor.
- d. **Slip Power Recovery:** In applications where regenerative braking is necessary, slip power recovery systems (SERS) are utilized to manage speed. SERS use additional circuits to collect the slip power from the rotor and send it back to the power source, regulating the motor's speed in the process.
- e. **Cascade Control:** To improve dynamic performance, cascade control combines speed control and torque control. It uses an inner torque control loop and an outer speed control loop as its two control loops. The speed control loop modifies the motor's speed based on the output of the torque control loop, which modifies the motor's torque.
- f. **Direct Torque Control (DTC):** DTC is a sophisticated control method that offers quick and precise torque and speed management without the need for a separate position or speed sensor. To directly manage torque and flux, DTC makes use of the motor model and measurements of stator currents and voltages. It provides accurate control and outstanding dynamic response.
- g. **Control without Sensors:** Sensor less control techniques do not require external speed or location sensors. These methods make estimates of the rotor position and speed based on stator current and voltage measurements. Sensor less control techniques can lower costs and improve system reliability, but proper estimation necessitates sophisticated algorithms.
- h. **Pulse Width Modulation (PWM):** PWM techniques quickly turn on and off the motor's power supply, efficiently regulating the average voltage and speed. PWM offers finer control, lower harmonic content, and more effectiveness. It frequently works in tandem with inverters or VFDs.



Each speed control system has benefits and drawbacks, and choosing the best one for a given application depends on things like the needed speed range, torque characteristics, efficiency standards, and cost considerations.

**Variable Voltage Variable Frequency Control(VVVF):** Voltage that varies by varying the voltage and frequency of the power delivered to the motor, a technique known as variable frequency (VVVF) control can be used to regulate the speed and torque of electric motors. This control method is widely employed in many different applications, such as business operations, transportation networks, and renewable energy sources. We shall discuss the idea of VVVF control, as well as its benefits and applications, in this post. The idea behind VVVF control is that an AC motor's speed is inversely proportional to the frequency of the power applied to it. The voltage and frequency can be changed in order to precisely adjust the motor's speed and torque. Applications that need for accurate speed control, smooth acceleration and deceleration, and minimal energy usage benefit most from this control technology. A power source, an inverter, a microcontroller or digital signal processor, and the motor itself make up the VVVF control system.

The power source transforms the grid's incoming AC power into a DC voltage. This DC voltage is then changed into an AC voltage by the inverter, which has a variable frequency and amplitude. The voltage and frequency output of the inverter are adjusted in accordance with the motor's speed and torque needs by the microcontroller or digital signal processor. In order to complete the desired task, the motor finally transforms electrical energy into mechanical energy. In VVVF systems, the control method is frequently based on pulse-width modulation (PWM). PWM operates by abruptly turning on and off the electricity supplied to the motor at a set frequency. The average voltage and, consequently, the motor's speed, can be changed by varying the breadth or duration of each pulse. The needed pulse width is determined by the system's control logic or the intended speed or torque specified by the operator by the microcontroller or digital signal processor. VVVF control has a number of benefits over other conventional forms of motor control.

First off, it offers accurate speed control under a variety of operating circumstances. Elevators, conveyor belts, and machine tools are just a few examples of applications that benefit from the smooth and exact acceleration and deceleration made possible by the ability to modify both the voltage and frequency. Second, efficient energy usage is made possible by VVVF control. The system can minimize energy losses and maximize motor efficiency by regulating the voltage and frequency in accordance with the requirements of the motor under load. This energy-saving function is crucial in sectors like HVAC systems, pumps, and compressors where motors use a large amount of electricity. The motor and the driving machinery are less mechanically stressed because to VVVF regulation. It lowers wear and tear on the mechanical components, prolonging their lives and lowering maintenance costs by offering smooth acceleration and deceleration.

VVVF control is used in a variety of systems and sectors. VVVF control enables precise speed and acceleration control in transportation systems, such as electric trains and trams, leading to smoother trips and lower energy use. VVVF control is used in renewable energy systems to maximize the energy derived from these sources by optimizing the operation of solar tracking systems and wind turbines. To sum up, variable voltage variable frequency (VVVF) control is a flexible and effective way to regulate the speed and torque of electric motors. It offers accurate

speed control, increased energy economy, and decreased mechanical stress by regulating both the voltage and frequency provided to the motor. VVVF control is widely used in many different industries and is essential for maximizing the performance of systems that are powered by electric motors[10].

**Field Oriented Control(FOC):**A control method used to precisely manage the speed and torque of AC motors, notably three-phase induction motors and synchronous motors, is called field-oriented control (FOC), sometimes known as vector control. FOC enables high-performance and effective motor operating by providing independent control of the magnetic flux and torque components of the motor. We shall examine the idea of field-oriented control, along with its guiding principles, benefits, and applications, in this post. Decoupling the control of the magnetic flux (sometimes referred to as the field) and torque components of the motor is the essential tenet of field-oriented control. It is feasible to drive the motor as though it were a separately excited DC motor by disconnecting these components, which makes the control method simpler and boosts performance.

FOC entails converting the motor's three-phase AC currents and voltages into the d-q reference frame, a rotating reference frame with two coordinates. The torque component is represented by the q-axis in this frame, while the magnetic flux component is represented by the d-axis. Mathematical transformations, such as the Park and Clarke transforms, are used to create the transformation. The control algorithm can separately control the magnitude and phase angle of the current components in the d-q reference frame, consequently regulating the magnetic flux and torque of the motor. The motor currents are normally adjusted by the control algorithm based on the intended speed and torque setpoints using a proportional-integral (PI) controller or more sophisticated control approaches, like model-based controllers or adaptive control algorithms. Field-Oriented Control has many advantages. To begin with, FOC enables precise and dynamic control of motor speed and torque.

The motor can respond to changes in the control commands quickly and accurately by independently managing the magnetic flux and torque components. FOC is thus appropriate for applications requiring high-performance motor control, such as industrial automation, robotics, and electric cars. Second, excellent motor efficiency is made possible by FOC. The control algorithm can maximize motor efficiency and decrease energy losses by tuning the magnetic flux and torque components. This is crucial in applications like electric vehicles and renewable energy systems where energy efficiency is essential. Field-Oriented Control also enhances motor efficiency and stability. It lessens the impact of one component on the other by disengaging the control of magnetic flux and torque, resulting in a smoother and more stable motor performance. This increases the motor's capacity to manage disturbances and fluctuations in load, improving system reliability as a whole. FOC is widely used in many different fields and applications.

Electric vehicle propulsion systems frequently use it to produce effective and dynamic motor control. FOC is used in industrial automation to precisely control motors in conveyor systems, machine tools, and robotics. In order to maximize energy production and grid integration, it is also used in renewable energy systems, such as wind turbines and hydropower generators. by separating the management of the magnetic flux and torque components, Field-Oriented management (FOC) is a potent control technique that permits accurate control of AC motors.

FOC has applications in a variety of industries and helps enhance automation, renewable energy systems, and electric mobility by offering high-performance, efficient, and stable motor control.

**Direct Torque Control (DTC):**In order to obtain exact and dynamic control of motor torque and speed, direct torque control (DTC) is a control technique used in AC motor drives. DTC is renowned for its capacity to deliver quick and precise torque response while keeping the control algorithm's complexity to a minimum. The idea of direct torque control, as well as its benefits and applications, will be discussed in this article. The essential idea behind direct torque control is to directly regulate the flux and torque of the motor without the need of any intermediary processes, such field-oriented control. DTC accomplishes this by monitoring the motor's flux and torque readings continually and modifying the control variables as necessary. The control algorithm for DTC determines the intended motor voltage vector and chooses the best voltage vector from a preset collection of voltage vectors. DTC operates in a discrete time domain. Based on minimizing the difference between the actual and intended torque and flux values, a choice is made. Torque control, flux control, and voltage vector selection make up the three primary parts of the DTC control algorithm. Based on user input or system demands, the torque control component determines the desired torque. The magnetic flux of the motor is controlled by the flux control component to a predetermined reference value. Based on the torque and flux errors, the voltage vector selection component chooses the best voltage vector to apply to the motor. DTC has a number of benefits over other control methods. First off, it provides quick and precise torque control.

DTC is appropriate for applications that demand quick and precise torque changes, such as robots, machine tools, and material handling systems because it directly controls the torque and achieves a rapid torque response and perfect torque regulation. Additionally, DTC offers outstanding dynamic performance. Fast sampling and calculation are made possible by the control algorithm's discrete character, which leads to speedy torque and flux adjustments. As a result, the motor can react to changes in load conditions quickly, resulting in stable and effective functioning. The robustness of DTC to parameter changes and disruptions is another benefit. DTC is less susceptible to changes in parameter since it does not rely on accurate motor parameter information. Additionally, the discrete character of DTC's control mechanisms aids in the rejection of disturbances, ensuring steady motor performance even in the face of outside disturbances.

DTC is used in a variety of systems and businesses. In order to produce effective and responsive motor control, which improves vehicle performance and energy economy, it is frequently employed in electric and hybrid electric vehicles. In high-speed machinery, robots, and servo systems used in industrial automation, precise torque and speed control is essential. To maximize power production and grid integration, it is also used in renewable energy systems like wind turbines and hydroelectric generators. Direct Torque Control (DTC) is a control method that directly modifies the flux and torque of an AC motor to give accurate and dynamic control. With its quick torque response, superior dynamic performance, and tolerance to shocks, DTC offers benefits in a variety of applications, from renewable energy systems to electric vehicles and industrial automation.

**Application Consideration of Starting and Speed Control of Three Phase Induction Motor:**Several aspects need to be taken into account when evaluating the use of starting and

speed control strategies for three-phase induction motors. These factors aid in choosing the best approach for a certain application. The following are some crucial things to think about:

- a. **Motor Power Rating:** Choosing the best starting and speed control strategy depends in large part on the motor's power rating. Direct-on-line (DOL) starting can frequently provide an appropriate starting solution for smaller motors with lower power ratings. However, more advanced starting methods like star-delta beginning or auto-transformer starting may be advantageous for larger motors with greater power ratings.
- b. **Load Characteristics:** The type of load that is connected to the motor has a significant impact on the requirements for starting and speed control. The torque requirements, starting torque specifications, and speed fluctuations vary depending on the load. The adoption of approaches that offer a higher torque during the starting phase, such as star-delta starting or variable frequency drive (VFD) control, may be necessary for heavy loads with high starting torque needs. Direct-on-line (DOL) starting or other easier beginning procedures might be appropriate for lighter weights.
- c. **Speed requirements:** It is essential to take into account the desired speed range and control precision. Techniques like field-oriented control (FOC) or direct torque control (DTC), which are capable of providing accurate and dynamic speed regulation, may be preferred if precise speed control is required for the application. In addition to providing flexible speed control, variable frequency drive (VFD) control is ideally suited for applications that call for varied speeds or speed ramps.
- d. **Efficiency and Energy Savings:** In many applications, energy efficiency is a crucial factor. By altering the motor's speed and matching it to the load needs, variable frequency drive (VFD) control techniques can help improve energy consumption. Energy savings are possible by lowering the speed when full power is not required. By reducing losses and enhancing motor performance, VVVF control and other sophisticated control strategies like FOC and DTC also help to increase efficiency.
- e. **Application-Specific Requirements:** Depending on the application, several beginning and speed control methods may be selected. For instance, approaches like DTC or VFD control with quick response times might deliver the appropriate performance in applications requiring rapid acceleration or deceleration. Techniques that reduce mechanical stress during starting, such star-delta starting, may be advantageous for applications that frequently start and stop, like conveyors or cranes.
- f. **Cost considerations:** It's important to assess the costs associated with putting various beginning and speed control approaches into practice. Simpler methods like DOL beginning might be more economical, but they might not offer as much control or efficiency as more sophisticated methods. The advantages and performance needs of the application should be considered when comparing the costs of extra equipment, such as variable frequency drives or control systems.

You may choose the best starting and speed control method for a three-phase induction motor by carefully taking into account these application-specific criteria. The chosen method must be compatible with the motor's power rating, the load's characteristics, the application's speed requirements, efficiency objectives, and any other particular needs.

## CONCLUSION

In this work, we looked into three-phase induction motor starting and speed control strategies. For applications where a large starting torque is not necessary, the direct-on-line (DOL) starting technique offers a quick and affordable solution for starting motors. The star-delta starter is appropriate for applications with low load needs because it provides a moderate beginning torque with reduced current during starting. The variable frequency drive (VFD) technology is a great option for applications demanding accurate speed control and energy savings. By adjusting the motor's frequency and voltage, VFDs enable smooth starting, customizable speed control, and efficient operation. This method is very useful in situations when different speeds are required, like in conveyor systems and pumps. In conclusion, the unique application requirements determine the starting and speed control method to use with a three-phase induction motor. While the VFD technique offers sophisticated control features and energy efficiency, the DOL and star-delta methods are appropriate for applications with various load characteristics. In varied industrial contexts, the selection and application of these approaches guarantee optimum motor performance, dependability, and energy savings.

## REFERENCES:

- [1] A. S. Zein El Din, A. E. Lashine, and S. S. Shokralla, "Improvement of starting characteristic and speed control of three-phase induction motor using microprocessor," *Electr. Mach. Power Syst.*, 1998, doi: 10.1080/07313569808955821.
- [2] G. Joshi and A. J. Pinto Pius, "ANFIS controller for vector control of three phase induction motor," *Indones. J. Electr. Eng. Comput. Sci.*, 2020, doi: 10.11591/ijeecs.v19.i3.pp1177-1185.
- [3] M. I. Abdelwanis, E. M. Rashad, I. B. M. Taha, and F. F. Selim, "Implementation and control of six-phase induction motor driven by a three-phase supply," *Energies*, 2021, doi: 10.3390/en14227798.
- [4] S. Grover and M. M. Mankar, "Minimization of Starting Torque and Inrush Current of Induction Motor by Different Starting Methods using MATLABSIMULINK," *Int. J. Trend Sci. Res. Dev.*, 2019, doi: 10.31142/ijtsrd22935.
- [5] A. Pradipta, S. Triwijaya, and M. Ridwan, "Performance and Analysis of Indirect Torque Control-Based Three-Phase Induction Motor," *ELKHA*, 2021, doi: 10.26418/elkha.v13i2.49181.
- [6] G. Akbar, M. Mughal, and S. S. H. S. Bukhair, "MATLAB/simulink modelings and experimental design of variable frequency drive for speed control of three-phase induction motor," *Int. J. Recent Technol. Eng.*, 2019, doi: 10.35940/ijrteB3068.078219.
- [7] M. S. A. Sari, H. Suyono, and A. Lomi, "Analysis of 3 Phase Induction Motor Speed Control with Direct Torque Control (DTC) Method Based on PID Control," *J. Ecotipe (Electronic, Control. Telecommun. Information, Power Eng.*, 2020, doi: 10.33019/jurnalecotipe.v7i2.1476.
- [8] A. A. Menaem, M. Elgamel, A. H. Abdel-Aty, E. E. Mahmoud, Z. Chen, and M. A. Hassan, "A Proposed ANN-Based Acceleration Control Scheme for Soft Starting Induction Motor," *IEEE Access*, 2021, doi: 10.1109/ACCESS.2020.3046848.



- [9] X. Zhou, C. Wang, and Y. Ma, "Vector speed regulation of an asynchronous motor based on improved first-order linear active disturbance rejection technology," *Energies*, 2020, doi: 10.3390/en13092168.
- [10] M. I. Daoud, A. A. Elserougi, A. M. Massoud, R. Bojoi, A. S. Abdel-Khalik, and S. Ahmed, "Zero-/Low-Speed Operation of Multiphase Drive Systems With Modular Multilevel Converters," *IEEE Access*, 2019, doi: 10.1109/ACCESS.2019.2893526.

## GENERALIZED THEORY OF ELECTRICAL MACHINES

**Mr. Sreekanth Kondreddy\***

\*Assistant Professor

Department of Electrical And Electronics Engineering,  
Presidency University, Bangalore, INDIA  
Email Id-ksreekanthreddy@presidencyuniversity.in

---

### ABSTRACT:

*A thorough framework that offers a unifying method for studying and modeling numerous kinds of electrical machines is called the Generalized Theory of Electrical Machines (GTEM). With the help of this theory, it will be possible to comprehend the behavior and operation of various machine topologies, including DC machines, synchronous machines, and induction machines. GTEM makes it easier to analyze machines under various operating situations and enables the creation of effective control techniques by utilizing a broad mathematical framework. This chapter gives a general introduction of the GTEM, outlining its main ideas, mathematical formulation, and electrical machine applications.*

**KEYWORDS:** *Basic Two-Pole Machine, Clarke Transformation, Kron's Primitive Machine, Park's Transformation, Three Phase System.*

---

### INTRODUCTION

The study of electrical machinery has been essential to the growth and development of contemporary society. Electrical devices, such as motors and generators, are crucial elements in a variety of applications, from renewable energy systems to industrial automation and transportation. For effective operation and ideal design, it is essential to comprehend how these devices behave and work. To evaluate and simulate electrical machinery, numerous theories and models have been created over time. The Generalized Theory of Electrical Machines (GTEM), which offers a consistent methodology for researching various types of machines, is one such theory. The GTEM creates a common framework that transcends the limitations of specific machine topologies, which marks a key turning point in the field of electrical machines.

Traditional theories lack a consistent mathematical formulation and frequently concentrate on certain machine types, such as DC machines, synchronous machines, or induction machines. The development of sophisticated control schemes and optimization methods is hampered by the difficulties presented by this fragmented approach when examining and contrasting various machine topologies. By proposing a generalized mathematical framework that covers a wide range of electrical devices, the GTEM addresses these constraints. A common language and set of guiding principles for the analysis and modeling of electrical machines are the main goals of the GTEM. It is feasible to examine the behavior and performance of machines under diverse operating settings by using a generalized method, regardless of their unique topology. This makes it possible for scientists and engineers to comprehend the fundamental ideas that underlie machine operation better, supporting the creation of sophisticated control strategies and optimization algorithms.

The GTEM's capacity to encompass the distinctive features of several machine topologies under a single mathematical framework is one of its main advantages. It has always been difficult to compare the performance of various machine kinds or come up with universal control schemes since different machine type's call for different mathematical models and analysis methods. By chaptering the key components of any machine architecture and re-creating them as generalized mathematical equations, the GTEM gets over this restriction. As a result, it is possible to analyze machines holistically and with ease identify and compare their similarities and differences. Additionally, the GTEM makes it easier to model and simulate electrical devices in a variety of operating environments. The theory permits the creation of thorough machine models that can precisely describe the dynamic behavior of machines during transient events, steady-state operation, and fault circumstances by adding a generalized mathematical framework.

This skill is essential for building reliable control systems that can adjust to changing operating conditions as well as for forecasting and optimizing machine performance. The GTEM's applicability to the field of control systems and optimization is a significant additional benefit. The theory facilitates the construction of sophisticated control techniques that can be applied to many machine topologies by offering a unifying mathematical model of electrical machines. This creates new opportunities for raising system stability, enhancing energy effectiveness, and maximizing machine performance. The GTEM also enables the seamless coordination and management of several machines for the best power generation, transmission, and distribution. This is done by integrating electrical machines into intricate power systems. The Generalized Theory of Electrical Machines (GTEM), in conclusion, is a significant development in the study of electrical machines. GTEM offers a single language and set of rules for studying and modeling various types of machines by presenting a unified mathematical framework. By incorporating the distinctive traits of diverse machine topologies into a single framework, this theory overcomes the limits of conventional theories. The GTEM makes it easier to comprehend how machines behave, allows for precise modeling and simulation, and helps the creation of cutting-edge control schemes and optimization methods. Finally, by offering a complete tool for developing, assessing, and operating electrical machines, the GTEM advances electric power systems and energy conversion technologies[1]–[3].

**Basic Two-Pole Machine:** A simplified illustration of an electrical machine made up of a rotor and a stator, each with two magnetic poles, is known as a basic two-pole machine. This machine acts as a fundamental building block for comprehending electrical machine concepts and is frequently employed as a starting point for researching more intricate machine topologies. In a standard two-pole machine, the rotor is normally a cylindrical part that revolves inside the stator. Two magnetic poles, known as the north and south poles, are used in its construction, and they are either magnetized by permanent magnets or by an excitation current. To create torque and make it possible to convert electrical energy to mechanical energy, or the other way around, the magnetic field of the rotor interacts with the magnetic field created by the stator. On the other hand, the stator, which encloses the rotor, is a stationary element. Additionally, it has two magnetic poles that are positioned in two different directions to produce a magnetic field that interacts with the rotor's field.

To strengthen the magnetic field, the stator's poles are often built by winding coils around magnetic cores. An external power source or electrical source is linked to the coils, allowing for the creation of a spinning magnetic field. A rotating magnetic field is produced when an

electrical current is transmitted via the stator windings. In the case of a wound rotor, this revolving field induces a voltage that, in turn, produces a current in the rotor windings or, in the case of permanent magnets, results in the interaction of magnetic fields. The rotor rotates as a result of the torque created by the interaction of the magnetic fields of the stator and rotor. This rotational motion can be used to produce power or move mechanical loads. Depending on the application and the flow of energy, the fundamental two-pole machine can operate as a motor or a generator. The stator windings function as a motor when electrical energy is applied, transforming electrical energy into mechanical energy to move a load. The rotor, on the other hand, functions as a generator when it is mechanically driven, transforming mechanical energy into electrical energy.

Fundamental concepts like electromagnetic theory and circuit theory can be used to understand the behavior of the basic two-pole machine. To characterize its performance traits, such as torque-speed characteristics, efficiency, and power factor, mathematical models and equations can be constructed. These models help in the design and optimization of more complicated electrical devices by offering insights into the machine's operation. The fundamental two-pole machine, which shows how the magnetic fields of the rotor and stator interact, is a basic illustration of electrical machines. It offers a condensed framework for comprehending the fundamentals of electrical energy conversion and acts as a starting point for researching more intricate machine topologies. Engineering professionals can construct effective and dependable solutions for a variety of industrial and commercial applications by carefully examining the behavior and performance of electrical devices.

## DISCUSSION

**Transformer with a Moveable Secondary Winding:** A specific kind of transformer called a "transformer with movable secondary winding" has a secondary winding that can be physically changed in reference to the main winding. The transformer's voltage and current ratios can be adjusted thanks to this design's changeable coupling between the windings. The primary and secondary windings of a conventional transformer are fixed and stationary with respect to one another. The primary winding's magnetic field induces a voltage in the secondary winding, and the turns ratio controls the output's voltage and current levels. The secondary winding's position can be adjusted in a transformer with a moveable secondary winding, which changes the magnetic coupling between the windings and affects the transformer's performance. A sliding or rotating device that enables the winding to be physically moved is typically used to create the movable secondary winding. The magnetic coupling between the windings can be changed to alter the transformer's voltage and current transformation ratios. This is done by modifying the secondary winding's position.

This offers a way to regulate the transformer's output voltage or current. Voltage regulation is one of the main uses for a transformer with a variable secondary winding. The effective turns ratio can be altered, changing the output voltage, by moving the secondary winding's position. When a variable output voltage is needed, like in power supply systems or voltage regulation for delicate equipment, this capability is especially helpful. Transformers used for impedance matching are another example of an application. The transformer may match the impedance of the source and load by altering the coupling between the windings, maximizing the efficiency of power transfer. When signal integrity is important, this is frequently used in audio systems or

telecommunications equipment. In applications where precise control over the output voltage or current is required, transformers with variable secondary windings can also be employed. For experimental setups, laboratory tools, or specific industrial operations that demand exact control over power characteristics, this includes variable voltage transformers. It is important to note that compared to conventional fixed-winding transformers, transformers with moveable secondary windings may require additional design considerations.

To ensure smooth and dependable functioning, the mechanical mechanism utilized to change the winding position must be carefully constructed. For the transformer to remain functional and safe, mechanical stability and electrical insulation are essential. A transformer with a secondary winding that can be moved provides the ability to adjust the coupling between the windings, giving the user control over the ratios of voltage to current transformation. Applications made possible by this include impedance matching, voltage regulation, and accurate control of power characteristics. These transformers provide flexibility and adaptability in various electrical systems where changeable output voltages or currents are necessary by utilizing a movable secondary winding.

**Kron's Primitive Machines:** Often referred to as Kron's Primitive Theory, Kron's Primitive Machine is a theoretical framework for studying electrical power systems. It was created by Hungarian-American electrical engineer Arthur A. Kron in the 1930s and is based on the idea of simplification in machine representation when modeling power networks. A power system is represented by a collection of connected primitive machines in the context of Kron's Primitive Machine. Each primitive machine is a representation of an electrical machine, such as a motor or generator that is linked to a system of transmission lines and other electrical parts. The steady-state operation of the machine and the movement of power throughout the system are the main concerns of the basic machine model.

The main goal of Kron's Primitive Machine is to portray the complicated dynamics of power systems as a set of machine-simplified dynamics. Each primitive device is made up of an electrical device that is coupled to an equivalent impedance that corresponds to the properties of the transmission lines and network elements it is attached to. A collection of algebraic equations that represent the power flow and voltage relationships inside each primitive machine are used to describe the behavior of each machine. These equations are obtained using the network topology of the power system and the fundamentals of electrical circuit theory. A mathematical framework for evaluating the behavior and stability of power systems is provided by Kron's Primitive Machine. Engineers can investigate the steady-state behavior, power flow, and voltage profiles of the power system by simulating it as a collection of connected primitive machines. Potential problems like voltage drops, power losses, and system instability can be found with this study. One benefit of Kron's Primitive Machine is its simplicity, which makes it possible to compute and analyze enormous power systems effectively.

Engineers may evaluate the effects of various operating circumstances and system parameters on the performance of the entire system thanks to the model, which offers a systematic method for researching the interactions between machines and the power network. Kron's Primitive Machine, it should be noted, is a simplification of the actual complexity of power systems. It makes the assumption that everything is in a steady state and ignores dynamic impacts like transient behavior or control actions. Therefore, more complex and detailed models are needed



for thorough power system analyses, even though they are beneficial for early analysis and approximation. Kron's Primitive Machine is a conceptual framework for analyzing electrical power systems. It simplifies complex dynamics and enables effective study of steady-state power flow and voltage profiles by depicting a power system as a collection of connected primitive machines. For a thorough understanding of power system operation and stability, it is crucial to combine this simplified model with more in-depth and thorough analysis approaches, even if it offers insightful information on power system behavior[4]–[6].

**Linear Transformations in Machines:**In machine learning and many related applications, linear transformations are crucial. A mathematical procedure known as a linear transformation uses a linear equation to convert an input vector to an output vector. Linear transformations are frequently used in the context of machine learning to process and change input data for tasks including feature extraction, dimensionality reduction, and classification. Matrix representations of linear transformations are common in machine learning. The elements of the output vector are obtained by multiplying each element of the input vector by its corresponding element in the matrix and then adding the resulting products. The computation of the transformation can be done quickly and effectively thanks to this matrix multiplication. Feature extraction is a typical machine learning application for linear transformations. It is feasible to extract new features or representations that capture significant patterns or relationships in the data by applying a linear transformation to the input data.

For instance, in image processing, features from images are extracted using linear transformations like convolutional processes, enabling tasks like object detection and recognition. Principal component analysis (PCA) and other dimensionality reduction strategies make use of linear transformations as well. PCA tries to maintain the key characteristics of high-dimensional data while reducing its dimensionality. This is accomplished by identifying a linear transformation that maximizes the variance of the converted data while mapping the input data to a lower-dimensional space. The most important information is retained after this linear transformation, which is symbolized by an orthogonal matrix. Additionally, the core of linear regression models are linear transformations. A linear relationship between input features and a target variable is what linear regression seeks to fit. The input features teach the model the coefficients of the linear transformation that best predicts the target variable.

Based on the input data, this linear transformation makes it possible to forecast the target variable. In neural networks, linear transformations are very frequently used, especially in the form of linear layers or completely connected layers. In a neural network, the input data is first transformed linearly by a linear layer before being subjected to a nonlinear activation function. With the help of this combination, neural networks may learn intricate mappings between input and output regions, enabling operations like speech recognition, image classification, and natural language processing. Finally, it should be noted that linear transformations are essential to machine learning and many other applications. They allow for the processing and manipulation of input data, the extraction of useful characteristics, the reduction of dimensionality, and the modeling of relationships between variables. In many machine learning algorithms, linear transformations serve as a fundamental building element and are crucial for resolving a variety of tasks.

**Three-Phase to Two-Phase Transformation:** A three-phase electrical system can be transformed into an equivalent two-phase system via a process called three-phase to two-phase transformation, also known as symmetrical component transformation. The analysis and representation of three-phase systems can be sped up and simplified by using this transformation, which is frequently used in power system analysis and control. The transformation is based on the idea that a three-phase system that is balanced can be divided into two separate, symmetrical components known as positive sequence and negative sequence. The balanced set of phasors rotating in the same direction is represented by the positive sequence component, and the balanced set of phasors revolving in the opposite direction is represented by the negative sequence component. The following procedures are commonly taken to achieve the three-phase to two-phase transformation:

- 1. Extraction of the Positive Sequence Component:** The average of the three phase values is used to extract the positive sequence component from the three-phase system. This entails maintaining the phase angles while summing the magnitudes of the three phases and dividing by three.
- 2. Extraction of the Negative Sequence Component:** From each individual phase, the average of the three phase variables is subtracted to produce the negative sequence component. Angles of phase are kept.
- 3. Calculating the Zero Sequence Component:** The negative of the sum of the positive and negative sequence components can be used to get the zero-sequence component, which represents the unbalanced component of the system.

The three-phase system can be described as a two-phase system once the positive sequence, negative sequence, and zero sequence components have been acquired. While the zero-sequence component is frequently overlooked in two-phase analysis, the positive and negative sequence components can be thought of as the two phases of the analogous two-phase system. Because it makes the depiction of imbalanced states easier to understand and makes it easier to analyze system behavior during faults, the conversion from three-phase to two-phase is especially helpful in fault analysis. The study can concentrate on the behavior of the positive and negative sequence components independently by splitting a three-phase system into two phases.

It is crucial to remember that the three-phase to two-phase transformation is merely an approximation that takes balanced conditions for granted and ignores some system characteristics like unbalanced loads and harmonics. As a result, it is mostly applied as a technique for simplification or for early analysis in power system studies. A three-phase electrical system can be transformed into an analogous two-phase system via a process called three-phase to two-phase transformation, also known as symmetrical component transformation. It includes excluding the zero-sequence component from the three-phase system and extracting the positive sequence and negative sequence components. This transformation makes it easier to analyze three-phase systems, especially when studying system stability and faults.

**Rotating Axis to Stationary Axis Transformation:** The Park's transformation, also known as the dq transformation or the rotating axis to stationary axis transformation, is a mathematical method for changing variables from a revolving reference frame to a stationary reference frame. This transformation is frequently used in the analysis and management of spinning electrical equipment, including synchronous and induction motors. The variables for electrical values, such

as currents and voltages, are represented in a rotating reference frame in terms of their amplitude and angle with respect to the rotating frame. However, working in a stationary reference frame, where the variables are represented with regard to fixed coordinates, is frequently desired for many analysis and control applications. The study and control of rotating electrical devices are made easier by the Park's transformation, which enables the conversion of variables from the revolving frame to the stationary frame. The transformation rotates the coordinate axes to line up with the spinning frame and is based on the idea of vector projection. The following steps are often included in The Park's transformation:

a. **Coordinate Rotation:** The angular location of the rotating frame in relation to the stationary frame serves as the basis for its definition. The axes of the coordinate system are rotated by an angle equal to the angular position's opposite. A mathematical procedure called coordinate rotation, sometimes referred to as coordinate transformation or coordinate rotation transformation, involves altering the coordinate system used to describe a collection of points or vectors. This transformation is frequently used to streamline calculations or examine data in a different coordinate frame in a number of disciplines, including mathematics, physics, computer graphics, and robotics. By rotating the coordinates, one can describe the points or vectors in a different coordinate system that can be more advantageous for the current issue. The geometry or relationships between the points can be understood or analyzed more easily by changing the coordinates. A Cartesian coordinate system's axes are commonly rotated by a specific amount to accomplish a coordinate rotation in a two-dimensional space. Depending on the convention being utilized, the rotation might be either clockwise or counterclockwise. The trigonometric relationships between the old and new coordinate axes determine the new coordinates. The following equations can be used, for instance, to determine the new  $x'$  and  $y'$  coordinates from the old  $x$  and  $y$  coordinates in a counterclockwise rotation of an angle:

$$x' = x * \cos(\theta) - y * \sin(\theta)$$

$$y' = x * \sin(\theta) + y * \cos(\theta)$$

These equations show how each point  $(x, y)$  changes to its corresponding point  $(x', y')$  upon rotation. The amount and direction of the rotation are determined by the angle  $\theta$ . Since rotations around numerous axes are required in three-dimensional space, coordinate rotation can be more difficult. To describe the rotation in three dimensions, there are numerous rotation conventions, including rotation matrices and Euler angles. There are numerous uses for coordinate rotation in various industries. Calculations can be made easier by translating coordinates to a more practical frame while studying object motion in physics. Coordinate rotation is a tool used in computer graphics to translate, scale, and rotate graphic elements by manipulating and transforming objects in 2D or 3D spaces.

The position and orientation of robot arms or other objects in space must be determined using coordinate rotation in robotics. It's crucial to remember that coordinate rotation keeps track of angles and distances between points. In other words, even though the points' coordinates in the new coordinate system may differ, their relative relationships remain the same. The coordinates of points or vectors can be changed from one coordinate system to another via the mathematical procedure known as coordinate rotation. It is applied to streamline computations or conduct data analysis in a new coordinate system. Coordinate rotation is a fundamental tool for

comprehending and modifying spatial connections and is used in a variety of disciplines, including mathematics, physics, computer graphics, and robotics[7]–[9].

**b. Clarke Transformation:** The spinning frame's three phase variables are transformed using the Clarke transformation into two orthogonal components. A linear combination of the three-phase values is used in the Clarke transformation to translate the three-phase variables to a two-dimensional space. A set of three-phase electrical variables can be transformed mathematically into a two-dimensional reference frame using the Clarke transformation, also known as the transformation. Electrical engineering frequently uses this transformation, particularly in three-phase systems analysis and control techniques. Charles Wilson Clarke, a British engineer who popularized the idea in the early 20th century, is honored by having the Clarke transformation named after him.

It is widely utilized in many different applications, such as power electronics, renewable energy systems, motor control, and power quality evaluation. The Clarke transformation entails mapping the three-phase numbers, often voltages or currents, to the reference frame, which is a two-dimensional frame of reference. The initial three-phase quantities are represented in this reference frame by two orthogonal components, and. The rotating reference frame, sometimes referred to as the rotating d-q frame or the Clarke reference frame, is the foundation of the transformation. The transformation is completed by calculating the  $\alpha$  and  $\beta$  components from the three-phase quantities using trigonometric relationships. The Clarke transformation is frequently calculated using the following equations:

$$\alpha = a$$

$$\beta = (2/\sqrt{3}) * (b - c/2)$$

The three-phase quantities, typically voltages or currents, are represented by letters a, b, and c in the equations above. The changed quantities in the Clarke reference frame are represented by the components  $\alpha$  and  $\beta$ .

By lowering the complexity involved in working with three-phase values, the Clarke transformation facilitates the study and control of three-phase systems. The analysis can be carried out in a two-dimensional space by mapping the three-phase quantities to the reference frame, which makes it simpler to apply control algorithms and derive relevant information. The Clarke transformation's ability to distinguish between the positive-sequence component and the negative-sequence and zero-sequence components is one of its key advantages. The balanced component of the three-phase system is the positive-sequence component, represented by the component  $\alpha$ . The unbalanced or asymmetrical components are represented by the component  $\beta$ . In three-phase systems, this separation makes fault detection, power quality analysis, and control techniques easier.

The Park transformation, also known as the  $\alpha\beta$  to dq0 transformation, is frequently combined with the Clarke transformation to further streamline the analysis and control of three-phase systems. The Park transformation turns the dq reference frame, which is aligned with the rotating magnetic field in AC machines, into a rotating version  $\alpha\beta$  of the reference frame. Combining the Clarke and Park transformations enables effective control algorithms and precise characterization of the behavior of AC machines. As a mathematical method, the Clarke transformation transforms three-phase electrical values into a two-dimensional reference frame. By separating

the balanced and unbalanced components, it makes three-phase system analysis and control simpler. Electrical engineering applications that involve motor control, power electronics, and power quality analysis frequently use the Clarke transformation.

c. **Park's Transformation:** The two orthogonal components acquired from the Clarke transformation are then rotated to the stationary reference frame using the Park's transformation. The sine and cosine terms of the angular position are multiplied by the Clarke components in this transformation. The dq0 transformation, sometimes referred to as Park's transformation, is a mathematical method used in electrical engineering to make three-phase AC system analysis and control simpler. Three-phase quantities, like voltages or currents, must be transformed into a two-dimensional reference frame that is in line with the system's rotating magnetic field. John Park, an American engineer who first proposed the idea in the middle of the 20th century, is the subject of the term Park's transformation.

It is frequently utilized in systems for renewable energy, power system analysis, and motor control. The Clarke transformation, which transforms the three-phase quantities into a two-dimensional  $\alpha\beta$  reference frame, is often followed by the Park's transformation. The Park's transformation further simplifies the analysis by rotating the reference frame to a new reference frame in line with the spinning magnetic field. The Clarke transformation divides the balanced and unbalanced components of the three-phase system. In order to implement the Park's transformation, the reference frame is rotated by an angle equal to the electrical angle of the revolving magnetic field. In an AC machine, the rotor's position or the system frequency often determine the angle. The following are the Park's transformation equations:

$$d = \alpha * \cos(\theta) + \beta * \sin(\theta)$$

$$q = -\alpha * \sin(\theta) + \beta * \cos(\theta)$$

In the above equations, d and q represent the transformed quantities in the rotating dq reference frame, and  $\alpha$  and  $\beta$  represent the quantities in the  $\alpha\beta$  reference frame obtained from the Clarke transformation.  $\theta$  is the electrical angle or rotor position angle.

The direct-axis and quadrature-axis components of the initial three-phase values are represented by the converted quantities, d and q, in the dq reference frame. The quadrature axis (q-axis) is orthogonal to the direct axis (d-axis), which is aligned with the magnetic field of the rotor. Due to the ability to decouple the components in the dq reference frame, the Park's transformation makes it easier to analyze and regulate AC systems. The analysis can be carried out as if it were a DC system by representing the quantities in the rotating dq reference frame, simplifying control methods and permitting correct modeling of AC equipment. The torque-producing (d-axis) and magnetizing (q-axis) components of the motor current can be independently controlled thanks to Park's transformation, which is frequently utilized in motor control applications. T

his enables methods like field-oriented control (FOC) for high-performance motor control and makes it easier to manage motor activity precisely. Park's transformation is employed in power system analysis for stability analysis, fault analysis, and control techniques. The three-phase values can be converted into the dq reference frame to improve the analysis of system behavior and the application of control strategies. To summarize, Park's transformation, commonly referred to as the dq0 transformation, is a mathematical technique used to make three-phase AC systems easier to analyze and operate. As a result, the rotating magnetic field aligns the spinning



dq reference frame with the rotating reference frame. This transformation is frequently used in motor control and power system analysis because it permits decoupled control of the components and accurate modeling of AC machines[10].

The variables are changed from the rotating frame to the stationary frame, where they can be conveniently evaluated or used for control, by performing Park's transformation. The direct axis (d-axis) and quadrature axis (q-axis) are generally used to display the transformed variables. While the q-axis component represents the variable perpendicular to the machine's magnetic flux, the d-axis component indicates the variable aligned with it. The analysis of the electrical and magnetic interactions within the machine and the development of control schemes to manage machine performance both benefit greatly from the employment of these components. In many different applications, including field-oriented control (FOC) of induction motors and synchronous machines, where precise control of torque and flux is needed, the rotating axis to stationary axis transformation is frequently used. It is simpler to create and apply control algorithms that precisely regulate the machine's behavior by translating the variables to the stationary frame. Park's transformation, also known as the rotating axis to stationary axis transformation, is a mathematical method for changing variables from a revolving reference frame to a stationary reference frame. By converting the variables into d-axis and q-axis components that are aligned with the magnetic field of the machine, it makes the analysis and control of spinning electrical machines simpler. This transformation is frequently utilized to enable precise and effective analysis and control techniques in applications like motor control and machine analysis.

**Physical Concept of Park's Transformation:** To make the study and control of spinning electrical devices simpler, electrical engineers frequently employ Park's transformation, commonly referred to as the dq transformation. Despite being essentially a mathematical transformation, Park's transformation is founded on significant physical ideas that are relevant to the behavior of rotating machines. Some of the fundamental physical ideas linked to Park's metamorphosis include:

a. **Rotating Reference Frame:** Variables declared in a rotating reference frame are transformed using Park's method. The coordinate axes are fixed to the rotating machine in this frame and rotate at the same rate as the rotor. In synchronous machines, where the rotor's motion is coordinated with the revolving magnetic field of the stator, the rotating frame is helpful for studying and characterizing the electrical values in the machine.

b. **Magnetic Flux:** The distribution of magnetic field lines within the machine is referred to as magnetic flux. Typically, the stator windings in rotating machines produce the magnetic flux, which interacts with the rotor to produce torque. The variable that is parallel to the magnetic flow is represented by the q-axis component in Park's transformation, whereas the variable that is aligned with the magnetic flux is represented by the d-axis component. The analysis and control of the machine's magnetic field are made simpler by this division into d and q components.

c. **Synchronous Machines:** The analysis and control of synchronous machines frequently make use of Park's transformation. In synchronous machines, the rotor rotates in time with the revolving magnetic field generated by the stator windings at a fixed speed. The variables in the revolving reference frame can be translated to a stationary reference frame by using Park's transformation, which makes it simpler to regulate the machine's torque and field.

d. **Field-Oriented Control (FOC):** The aim of field-oriented control is to separately control the torque and flux of the machine. It is a common control technique used in synchronous machines. As it enables the division of the variables into torque- and flux-producing components (d and q components), Park's transformation is essential to FOC. This division makes it possible to independently manage torque and flux, which improves the machine's performance and effectiveness.

e. **Transformation to Stationary Axis:** Variables are transformed from the rotating reference frame to the stationary reference frame using Park's transformation. The d-axis and q-axis components, which line up with the magnetic field and make analysis and control in the stationary frame easier, are used to represent the modified variables. The application of common control methods and the comprehension of machine behavior are made easier by this transformation, which also simplifies the analysis of rotating machines.

Engineers can use Park's transformation to study and manage rotating electrical equipment successfully by grasping these physical ideas. The transformation promotes the decoupling of torque and flux management, improves the comprehension of the magnetic field, and makes it easier to implement control techniques in synchronous machines.

## CONCLUSION

An effective and flexible method for examining electrical machines of many sorts and configurations is provided by the Generalized Theory of Electrical Machines (GTEM). Researchers and engineers can evaluate and simulate machines under various operating situations while taking into account the distinctive properties of each machine topology thanks to the introduction of a generalized mathematical framework (GTEM). This theory offers a common language for describing machine behavior, making it easier to compare and comprehend various machines. Additionally, GTEM facilitates the creation of effective control techniques by making it possible to optimize machine performance based on proven mathematical models. GTEM is a useful tool for designing, analyzing, and controlling electrical machines, which helps to enhance the technologies used in energy conversion and electric power systems.

## REFERENCES:

- [1] T. A. Lipo and T. J. Higgins, "Introduction to generalized electrical machine theory," *J. Franklin Inst.*, 1968, doi: 10.1016/0016-0032(68)90411-0.
- [2] I. Bachev, L. Stoyanov, V. Petrov, and E. Hadjiatanasova-Deleva, "Application of synchronous machines' models for distance learning purposes," in *2021 17th Conference on Electrical Machines, Drives and Power Systems, ELMA 2021 - Proceedings*, 2021. doi: 10.1109/ELMA52514.2021.9503005.
- [3] D. Finney, "Vector Control of AC Machines," *Power Eng. J.*, 1992, doi: 10.1049/pe:19920054.
- [4] M. Zablodskyi, V. Hrytsiuk, D. Morozov, and Y. E. Rudniev, "Electromechanical transducer for drying and processing of coal concentrates and sludges," *Min. Miner. Depos.*, 2016, doi: 10.15407/mining10.04.061.
- [5] L. Chang, "An improved fe inductance calculation for electrical machines," *IEEE Trans.*

- Magn.*, 1996, doi: 10.1109/20.508387.
- [6] A. Aktaibi, D. Ghanim, and M. a Rahman, "Dynamic Simulation of a Three-Phase Induction Motor Using Matlab Simulink," *20th Annu. Newfoundl. Electr. Comput. Eng. Conf.*, 2011.
- [7] P. S. Bimbhra, *Generalised Theory of Electrical Machines*. 2009.
- [8] A. R. Waghmare and V. A. Kulkarni, "Three-Phase to two-phase transformation of asynchronous machine by reference frame theory," *Int. J. Sci. Technol. Res.*, 2019.
- [9] J. G. Henderson, "Book Review: Introduction to Generalized Electrical Machine Theory," *Int. J. Electr. Eng. Educ.*, 1969, doi: 10.1177/002072096900600419.
- [10] P. Vas, "Electrical machines and drives: a space-vector theory approach," *Monogr. Electr. Electron. Eng.* 25, 1992.

## OVERVIEW OF ELECTRICAL ENERGY GENERATION

**Mr. Bishakh Paul\***

\*Assistant Professor,  
Department of Electrical And Electronics Engineering,  
Presidency University, Bangalore, INDIA  
Email Id-bishakhpaul@presidencyuniversity.in

---

### ABSTRACT:

*The generation of electrical energy is essential to modern society since it supports a wide range of businesses, domestic requirements, and technical breakthroughs. This chapter examines how electrical energy is produced, emphasizing the various sources and technologies at play. The influence on the environment and the requirement for the production of sustainable and renewable energy are also covered. To secure a dependable and sustainable energy future, the chapter emphasizes the significance of ongoing research and development in the area.*

**KEYWORDS:** *Electrical Energy, Energy Sources, Energy Efficiency, Electrical Energy Source, Renewable Energy Source, Thermal Power Plants.*

---

### INTRODUCTION

Energy is a vital requirement for a nation's economic growth. When the source of energy is interrupted, many activities essential to modern life come to a grinding halt. Estimating the precise contribution that energy has made to the development of modern civilization is very impossible. Large amounts of energy are now readily available, which has led to shorter workdays, increased industrial and agricultural output, a healthier and more balanced diet, and improved transportation infrastructure. In actuality, there is a direct correlation between a person's standard of living and the amount of energy he uses. A nation's population enjoys a higher level of living the higher its per capita energy consumption. In nature, energy can take many different forms, but electrical energy is by far the most significant. The utilization of electrical energy is so essential to our society that it has permeated every aspect of our way of life. In this chapter, we'll concentrate on the fundamental characteristics of electrical energy.

Our modern world is powered by electrical energy, which is a basic type of energy. It is a necessary resource that powers businesses, maintains communication networks, lights up our houses, and advances technology. Understanding electrical energy and how it is produced is essential for understanding the systems and infrastructure that give us the daily power we depend on. Electrical energy is fundamentally the capacity to perform work via the movement of electric charges. It comes from primary energy sources such as nuclear processes, fossil fuels, and renewable resources as a secondary form of energy. Through a variety of procedures and technological advancements, electrical energy is produced by converting a different form of energy into electricity [1]–[3].

The process of producing electrical energy is intricate and multifaceted. Utilizing fossil fuels, such as coal, oil, and natural gas, in thermal power plants is one of the most popular approaches. In this procedure, combustion is used to transform the chemical energy held in fossil fuels into

thermal energy. The steam generated by the thermal energy is then used to turn mechanical energy into electrical energy by powering a turbine that is connected to a generator. Fossil fuel-based generation, despite its extensive use, creates serious environmental problems, such as air pollution and greenhouse gas emissions. Another significant source of electrical energy is nuclear power generation. Nuclear fission, in which the nucleus of an atom splits into smaller fragments and releases a significant quantity of heat, is the source of the energy used in nuclear reactors. The steam created by this heat is then used to power a turbine-generator system, which creates electricity. A significant portion of the world's electricity comes from nuclear power plants, which also have the benefit of producing a lot of energy with just moderate levels of greenhouse gas emissions. However, there are still ongoing discussions and studies of other solutions due to worries about the secure disposal of nuclear waste and the possibility of accidents.

For the generation of electrical energy, there has been an increasing emphasis on renewable energy sources in recent years. Alternatives to conventional fossil fuel-based generating are available that are more ecologically friendly and sustainable, including solar, wind, hydro, and geothermal energy. Photovoltaic (PV) cells are used in solar energy to convert sunlight directly into electricity, harnessing the power of the sun. Utilizing the wind's kinetic energy to turn turbines and produce power is known as wind energy. While geothermal power uses the heat from the Earth's interior to produce electricity, hydroelectric power captures the energy of moving water by channeling it via turbines. Several reasons are responsible for the move to renewable energy sources. First off, there is less dependence on limited fossil fuel supplies thanks to the abundance and accessibility of renewable energy sources. Second, the production of renewable energy has much lower negative effects on the environment since it emits little to no greenhouse gases, lowering air pollution and halting climate change. Thirdly, as traditional energy sources get more expensive and advanced, renewable energy solutions are becoming more competitive.

Although renewable energy sources have many advantages, there are still difficulties. The intermittent nature of renewable sources is one of the main obstacles. The production of solar and wind energy is influenced by the time of day and the weather, which can cause variations in the amount of electricity available. In order to overcome this obstacle, effective energy storage systems must be created. These systems must be able to store extra energy produced during high-generation periods for use during low-generation periods. In summary, electrical energy is a necessary resource that drives our contemporary society. It can be produced via a variety of techniques, including as the combustion of fossil fuels, nuclear fusion, and the usage of renewable energy sources. While conventional methods have been effective for many years, the effects on the environment and the finite supply of fossil fuels have accelerated the shift to renewable energy production. Sustainable alternatives that minimize greenhouse gas emissions and stop environmental deterioration include solar, wind, hydro, and geothermal energy. In order to achieve a clean, efficient, and sustainable electrical energy future, it will be essential to continue developing renewable energy technology and energy storage options. We can guarantee a dependable and eco-friendly energy supply for future generations by adopting renewable sources and improving our energy systems.

**Generation of Electrical Energy:** The process of turning various energy sources into electricity, which powers our homes, businesses, and technological equipment, is known as electrical energy



generation. It entails the use of various technologies and energy sources to generate electrical power in order to meet the expanding energy needs of humanity.

The utilization of thermal power plants to generate electricity is one of the most used approaches. These power stations primarily generate heat by burning fossil fuels like coal, oil, or natural gas. The steam created by the heat is then utilized to power a turbine that is connected to a generator. The generator transforms the mechanical energy created by the turbine's rotation into electrical energy. Due to the abundance and low price of fossil fuels, thermal power plants have long been the main source of electricity. They are a serious environmental concern since they also have a big impact on air pollution and greenhouse gas emissions. Another popular technique for producing electrical energy is nuclear power. Nuclear fission, which occurs when an atom's nucleus splits into smaller pieces and releases a vast quantity of heat energy, is the process used in nuclear reactors. Through the use of a turbine-generator system akin to that used in thermal power plants, this heat is subsequently utilized to create steam and generate electricity. When it comes to producing big volumes of electricity with relatively low greenhouse gas emissions, nuclear power has an obvious advantage. However, secure nuclear waste disposal and potential accident hazards continue to be crucial factors in nuclear power generation.

Due to their sustainability and environmental friendliness, renewable energy sources are being used more and more to provide electrical energy. Photovoltaic (PV) cells, which turn sunlight directly into electricity, are used to capture solar energy. Solar power is now a competitive and practical option for the generation of electrical energy due to the rapid improvements in solar technology and the falling costs of PV systems. Another sustainable energy source is wind energy, which uses the kinetic energy of the wind to turn wind turbines and produce electricity. Onshore and offshore wind farms have expanded significantly in recent years, adding to the mix of renewable energy sources. The potential and kinetic energy of water is used in the production of hydroelectric electricity. Water is kept in reservoirs using dams or other types of water control structures. The water goes through turbines after being released, producing energy. Widely used hydroelectric power facilities offer a dependable source of renewable energy. In addition, geothermal energy production uses heat energy that is contained in the Earth's crust. Geothermal power stations generate electricity by using steam or hot water from underground reservoirs to turn turbines.

Reduced greenhouse gas emissions, climate change mitigation, and the need to ensure a sustainable energy future are the driving forces for the transition to renewable energy sources. Numerous benefits come with the development of renewable energy, such as the accessibility of plentiful resources, decreased dependency on fossil fuels, and reduced environmental effect. There are still issues, though, like the intermittent nature of some renewable energy sources and the requirement for effective energy storage devices to handle variations in electricity generation. the production of electrical energy is a dynamic and ever-evolving sector that uses a variety of sources and methods to transform various forms of energy into electricity. Nuclear and fossil fuel-based thermal power plants have been the traditional ways to generate electricity, but a growing interest in renewable energy sources like solar, wind, hydropower, and geothermal is changing the way that electricity is produced. In order to address environmental issues, reduce greenhouse gas emissions, and guarantee a sustainable energy source for future generations, renewable energy technology must be used. To further increase the effectiveness, dependability, and affordability of electrical energy generation from renewable sources, it will be essential to

continue research, development, and investment in renewable energy technology and storage systems[4]–[6].

## DISCUSSION

**Importance of Electrical Energy:** Energy may be required for motive power, heat, or other purposes. Electrical energy may now be transformed into any desired form thanks to modern advances in science and technology. As a result, electrical energy now holds a prominent part in the modern world. Low-cost, reliable electrical energy is essential to the continuation of industrial operations and our social institutions. In actuality, a nation's development is gauged by its electrical energy consumption per person. Due to the following factors, electrical energy is superior to all other types of energy:

- a. **Convenient Form:** Electricity is a very practical source of energy. It is simple to transform into different energy sources. For instance, all that needs to be done to turn electrical energy into heat is to feed electrical current through a wire with high resistance, such as a heater. Similar to how mechanical energy (such as electric motors) and light (such as electric bulbs) can be created via electrical energy.
- b. **Easy Control:** The starting, control, and operation of electrically powered devices are easy and convenient. For instance, flicking a switch on or off can start or stop an electric motor. The speed of electric motors can also be easily changed over the appropriate range with straightforward configurations.
- c. **Greater Flexibility:** The flexibility that electrical energy provides is a key factor in why it is preferred. With the aid of conductors, moving it from one location to another is simple. Cheapness: Compared to other energy sources, electrical energy is far more affordable. Utilizing this source of energy for domestic, commercial, and industrial applications is therefore often cost-effective.
- d. **Cleanliness:** Smoke, fumes, or hazardous gases are not related to electrical energy. Therefore, using it assures that the environment is clean and safe.
- e. **Excellent Gearbox Performance:** The locations of electrical energy users are typically very far from its producing centers. Transmission lines are overhead cables that carry electrical energy conveniently and effectively from electrical energy production centers to consumers.

**Generation of Electrical energy:** A produced goods like clothing, furniture, or tools is electrical energy. Similar to how raw materials found in nature must be transformed into the finished product when making a product, natural energy sources are also used to create electrical energy. Electrical energy, however, is unique in a crucial way. When compared to other commodities, which can be produced at will and used when needed, electrical energy must be generated and sent to the point of consumption right away. It simply takes a tiny fraction of a second to complete the process. Technical and financial considerations specific to the electrical power business are introduced by this rapid production of electrical energy. Natural sources of energy include the pressure head of water, the chemical energy of fuels, the nuclear energy of radioactive materials, and others. All of these energy sources can be transformed into electrical energy with the use of the proper setups. In essence, the setup uses (see Figure. 1) an alternator connected to a prime mover.

The energy obtained from a variety of sources, such as the burning of fuel, water pressure, wind force, etc., drives the prime mover. For instance, steam can be produced at high temperatures and pressures using the chemical energy of a fuel. A prime mover, such as a steam engine or a steam turbine, is supplied with steam. Steam heat energy is transformed into mechanical energy by the turbine and then into electrical energy by the alternator. Similarly, to this, other types of energy can also be transformed into electrical energy by using the appropriate tools and machinery. It is advisable to investigate the many sources of energy because electrical energy is created from the energy that is present in nature in a variety of ways. These energy sources include the Sun, the Wind, water, fuels, and atomic energy. Out of them, only the energy from the sun and wind have been widely employed because of a variety of restrictions. Currently, the production of electrical energy is mostly accomplished through the other three sources, namely water, fuels, and nuclear energy.

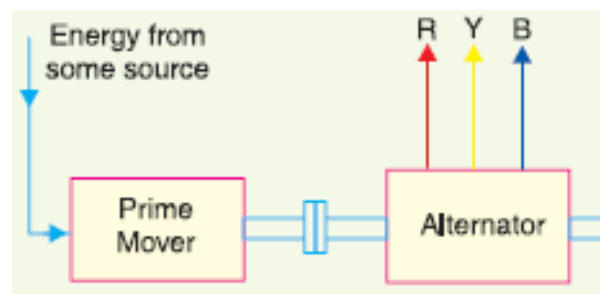

**Figure 1: Generation of Electrical Energy [Blog Spot].**

**The Sun:** The main source of energy is the Sun. Reflectors allow the sun's heat energy to be concentrated over a small area. With the use of a turbine-alternator combination, this heat may be used to generate steam, which can then be converted into electrical energy. This approach, however, has limited usage because it is (a) uneconomical, (b) ineffective in overcast or nighttime conditions, and (c) requires a huge area for the generation of even a tiny amount of electricity. However, there are some regions of the earth where high solar radiation is frequently received and there are few or no mineral fuel sources. Builders of solar power plants are increasingly interested in such places.

**The Wind:** Where the wind blows for a long time, this strategy can be applied. The windmill is powered by the wind, which also powers a small generator. The generator is set up to charge the batteries so that the windmill can continually provide electrical energy. When the wind ceases, these batteries provide the energy. The low maintenance and production expenses of this technology are a benefit. The disadvantages of this technology include (a) unpredictable output, (b) unreliability due to the unpredictability of wind pressure, and (c) very little power generated.

**Water:** Due to the heat produced when water is held in an appropriate location, it has potential energy. Water turbines can be used to transform this water energy into mechanical energy. The alternator, which transforms mechanical energy into electrical energy, is driven by the water turbine. Due to its low production and maintenance costs, this technique of producing electricity has gained a lot of popularity.

**Fuels:** The primary energy sources are fuels, specifically solid fuels like coal, liquid fuels like oil, and gas fuels like natural gas. Through the use of suitable prime movers such as steam engines, steam turbines, internal combustion engines, etc., the heat energy of these fuels is transformed into mechanical energy. The alternator, which transforms mechanical energy into electrical energy, is driven by the prime mover. Although fuels still hold a prominent position in the production of electrical energy, their reserves are running out every day. As a result, harnessing water power, which is essentially a permanent source of energy, is currently popular.

**Atomic energy:** It was found near the close of the Second World War that the fission of uranium and other fissionable elements releases a significant quantity of heat energy. According to estimates, 4500 tons of coal create the same amount of heat as 1 kilogram of nuclear fuel. With the right arrangements, the heat generated by nuclear fission can be used to raise steam. To generate electrical energy, the steam can power the steam turbine, which in turn can power the alternator. Nuclear energy use can provide certain challenges, though. The main ones are (a) the expensive expense of nuclear power plants (b) the issue with disposing of radioactive waste, and (c) a lack of qualified staff to operate the plant.

**Efficiency of Electrical energy:** Natural sources of energy include the pressure head of water, the chemical energy of fuels, the nuclear energy of radioactive materials, and others. By using an appropriate setup, all of these energy sources can be transformed into electrical energy. Some energy is lost during this conversion process since it is changed into a form other than electrical energy. As a result, the energy output is less than the energy input. Energy is defined as the output energy divided by the input energy efficiency or simply the efficiency of the system.

Efficiency = Output energy/ input energy

The ratio of useable output energy to input energy required to achieve that output is referred to as energy efficiency. It is a gauge of how well energy is utilized and converted in a specific system or process. More energy is transformed into usable output energy and less energy is lost when an energy system is more efficient. Due to its effects on resource utilization, economic effectiveness, and environmental sustainability, efficiency is a crucial factor in energy systems and processes. Reducing energy use, operating expenses and greenhouse gas emissions can all be achieved by increasing energy efficiency. Let's investigate how effective energy is in various situations:

**Efficiency of Energy Conversion:** Energy conversion is the transformation of one kind of energy into another. Power plants, engines, and other energy conversion devices all have different efficiency ratings. For instance, the typical efficiency of thermal power plants is between 30 and 40%, which means that only a small portion of the fuel's energy is turned into electrical energy. Similar to this, internal combustion engines in cars range in efficiency from 20 to 40%. Through the use of new technology and system improvements, efforts are continuously made to increase these efficiency [7]–[9].

**Efficiency in Energy Transmission and Distribution:** After being produced in a power plant, electricity must be distributed to end customers through a system of power lines and transformers. How much of the generated electricity is delivered to consumers depends on how effectively the transmission and distribution network operates. The infrastructure and the distance over which energy is transmitted can both affect transmission and distribution losses,

which include resistive losses and other inefficiencies. In order to reduce energy losses during transmission, modern power grids work to achieve high transmission and distribution efficiency.

**Energy Use Efficiency:** The efficiency with which energy is used by end-use systems and devices is referred to as energy usage efficiency. Appliances, heating and cooling systems, lighting, and industrial procedures all fall under this category. Optimizing equipment design, lowering standby power usage, deploying energy-saving technologies, and applying energy-efficient practices are all necessary to increase energy use efficiency. Energy-efficient appliances have been created to encourage greater efficiency and lower energy use, such as energy star-certified goods.

**Efficiency of the Overall Energy System:** An energy system's overall efficiency takes into account every step of the energy supply chain, from energy production and extraction through consumption. It considers how effectively energy is converted, transmitted, and used at each step. An all-encompassing strategy that incorporates renewable energy sources, smart grids, energy storage technologies, and energy management tactics is needed to maximize the efficiency of the total energy system. It also entails advocating for sustainable practices and taking energy conservation measures into account. A crucial approach to attaining energy sustainability and reducing negative environmental effects is to increase energy efficiency. It lessens reliance on fossil fuels, energy waste, and related greenhouse gas emissions. Governments, organizations, and people all recognize the value of energy efficiency and are taking action to improve it. This covers building codes, energy audits, retrofitting programs, and public awareness initiatives. In summary, energy efficiency is crucial for resource optimization, cost containment, and environmental sustainability. For a more sustainable and dependable energy future, improving energy efficiency at multiple stages of energy conversion, transmission, and utilization is essential. To get the most out of the energy we use, we need technological advancements, regulatory support, behavioral changes, and a shared commitment.

### **Advantages of Electrical Energy**

- a. **Versatility:** Electrical energy is incredibly adaptable and can be transformed into a variety of energies, including light, heat, and mechanical energy. Its broad range of uses in business, transportation, housing, and technology is made possible by its versatility.
- b. **Efficiency:** When compared to other energy sources, electrical energy has comparatively high conversion and utilization efficiency. For instance, high-efficiency electric motors are appropriate for a variety of applications, from industrial machinery to home appliances.
- c. **Instantaneous Transmission:** Through power networks, electrical energy may be instantly sent over great distances with little loss. This makes it possible for electricity to be efficiently distributed from power plants to end customers, assuring constant and dependable access to power.
- d. **Integration of Renewable Energy:** Renewable energy sources like sun, wind, hydropower, and geothermal energy can be used to produce electrical energy. This lessens dependency on fossil fuels and mitigates environmental effects by enabling the integration of clean and sustainable energy into the electrical system.
- e. **Automation and Control:** Electrical energy makes it possible to automate and control a variety of processes. It makes it possible to precisely control temperature, pace, and other



factors, boosting productivity, safety, and efficiency in both industrial and residential settings.

### **Negative Aspects of Electrical Energy:**

- a. Environmental Impact:** The production of electrical energy from conventional sources, such as fossil fuels, may have a negative impact on the environment. It leads to resource depletion, greenhouse gas emissions, and air pollution. Environmental harm can also result from the extraction and processing of materials used in electrical infrastructure, such as mining for minerals and metals.
- b. Energy Loss During Transmission:** Power lines' resistive heating causes energy losses during the long-distance transmission of electrical energy. Although these losses have decreased as a result of developments in gearbox technologies, they still exist and have the potential to degrade system efficiency.
- c. Grid Vulnerability:** Because centralized electricity grids are so dependent on them, they are vulnerable to disruptions brought on by calamities, cyberattacks, or defective equipment. The necessity for robust and decentralized energy systems is highlighted by the enormous economic and social effects that power outages can have.
- d. Energy Storage Challenges:** Electrical energy storage continues to present technological challenges. Due to the erratic nature of some renewable energy sources, like solar and wind, efficient and affordable energy storage systems are needed to store excess energy for use when there is a reduction in generation.
- e. Safety Hazards:** threats associated with electrical energy include electric shocks, fire threats, and short circuits. To reduce these dangers and guarantee safe use, proper safety measures, insulation, and upkeep are essential[10].

It is crucial to remember that by implementing sustainable and effective practices, many of the drawbacks of electrical energy can be reduced. To meet these issues and maximize the benefits of electrical energy while minimizing its downsides, energy storage technologies, grid resilience methods, and renewable energy technologies are constantly being developed.

### **CONCLUSION**

In order to meet the escalating demands of our modern civilization, the production of electrical energy is essential. Electricity is produced using a variety of sources and technologies, including fossil fuels, nuclear energy, and renewable sources including sun, wind, hydro, and geothermal energy. While fossil fuel-based power plants have long predominated as a source of electricity, the need for sustainable alternatives has arisen as a result of negative environmental repercussions such as greenhouse gas emissions and climate change. To sum up, the production of electrical energy is a dynamic industry that is always changing to satisfy the shifting needs of society. In order to reduce the environmental impact of power production and guarantee a reliable energy future, it is imperative to pursue sustainable and renewable energy sources. We can develop a cleaner, more effective, and sustainable energy system that benefits both the present generation and those to come through continued study and technical developments.

**REFERENCES:**

- [1] X. Luo, J. Wang, M. Dooner, and J. Clarke, "Overview of current development in electrical energy storage technologies and the application potential in power system operation," *Appl. Energy*, 2015, doi: 10.1016/j.apenergy.2014.09.081.
- [2] T. Bauer, C. Odenthal, and A. Bonk, "Molten Salt Storage for Power Generation," *Chemie-Ingenieur-Technik*. 2021. doi: 10.1002/cite.202000137.
- [3] S. Seme, B. Štumberger, M. Hadžiselimović, and K. Sredenšek, "Solar photovoltaic tracking systems for electricity generation: A review," *Energies*. 2020. doi: 10.3390/en13164224.
- [4] O. Ouramdane, E. Elbouchikhi, Y. Amirat, and E. S. Gooya, "Optimal sizing and energy management of microgrids with Vehicle-to-Grid technology: A critical review and future trends," *Energies*. 2021. doi: 10.3390/en14144166.
- [5] N. Zulkepli, J. Yunas, M. A. Mohamed, and A. A. Hamzah, "Review of thermoelectric generators at low operating temperatures: Working principles and materials," *Micromachines*. 2021. doi: 10.3390/mi12070734.
- [6] S. Hussain and L. Yangping, "Review of solid oxide fuel cell materials: cathode, anode, and electrolyte," *Energy Transitions*, 2020, doi: 10.1007/s41825-020-00029-8.
- [7] N. T. Mbungu, R. M. Naidoo, R. C. Bansal, and V. Vahidinasab, "Overview of the Optimal Smart Energy Coordination for Microgrid Applications," *IEEE Access*. 2019. doi: 10.1109/ACCESS.2019.2951459.
- [8] S. M. Ismael, S. H. E. Abdel Aleem, A. Y. Abdelaziz, and A. F. Zobaa, "State-of-the-art of hosting capacity in modern power systems with distributed generation," *Renewable Energy*. 2019. doi: 10.1016/j.renene.2018.07.008.
- [9] V. A. Gómez, C. Hernández, and E. Rivas, "Visión General, Características y Funcionalidades de la Red Eléctrica Inteligente (Smart Grid)," *Inf. tecnológica*, 2018, doi: 10.4067/s0718-07642018000200089.
- [10] "Thermoelectric materials, phenomena, and applications: A bird's eye view," *MRS Bulletin*. 2006. doi: 10.1557/mrs2006.44.

## MOTOR CONTROL BY STATIC POWER CONVERTER

**Mr. Veerappa Ravi\***

\*Assistant Professor,  
Department of Electrical And Electronics Engineering,  
Presidency University, Bangalore, INDIA  
Email Id-raviangadi@presidencyuniversity.in

---

### ABSTRACT:

*In this chapter, the use of static power converters in motor control systems is examined. To control the speed and torque of electric motors, static power converters are frequently employed in a variety of industrial applications. The essential concepts of motor control utilizing static power converters are covered in this essay, along with their benefits and drawbacks. The working principles and control schemes of various static power converter types, including rectifiers, inverters, and choppers, are examined. The chapter also discusses important factors to take into account while designing and implementing motor control systems that use static power converters. The results discussed in this chapter help to clarify the function of static power converters in motor control and offer guidance for further study and advancement in this area.*

**KEYWORDS:** *Choppers Motor-Control, Importance Motor-Control, Invertersmotor-Control, Motor Control System, Rectifiers Motor-Control, Static Power Converter.*

---

### INTRODUCTION

The use of electrical devices known as static power converters to control the speed, torque, and direction of electric motors is referred to as "motor control by static power converters." Static power converters are used to change the fixed voltage and frequency power supply into a variable voltage and frequency output suited for motor control. Examples of these converters include inverters and variable frequency drives (VFDs). To effectively and precisely adjust motor characteristics to satisfy particular application requirements is the main goal of motor control employing static power converters. The speed and torque characteristics of the motor can be changed by changing the voltage and frequency supplied to it, which enables smooth acceleration, deceleration, and operating under various loads. The power source, static power converter, control algorithms, and the motor itself are the main elements involved in motor control using static power converters.

The static power converter, which controls and transforms the power supplied to the motor, receives the necessary electrical energy from the power source. Based on user inputs or established control methods, the control algorithms used in the static power converter determine the intended motor performance. These algorithms control the static power converter's output voltage and frequency to produce the desired motor speed, torque, and direction. Simple open-loop control or more complex closed-loop control, which makes use of sensor feedback to increase precision and stability, are two different types of control algorithms. Static power converters can control motors with a number of benefits. By altering the motor characteristics according to the required load, it first enables efficient energy use by minimizing energy waste during periods of low demand. The second benefit is that it offers exact control over motor speed and torque, enabling accurate and seamless operation across a range of applications.

Regenerative braking, in which the energy produced during braking is recycled back into the power supply, is another benefit of motor control employing static power converters, which further improves energy efficiency. Static power converters are used to regulate motors in a variety of systems and industries[1], [2].

It is widely utilized in a variety of applications, including robotics, electric cars, renewable energy systems, HVAC (heating, ventilation, and air conditioning) systems, and others. To design and execute a successful motor control system, the unique control needs and motor characteristics for each application are taken into account. In conclusion, accurate adjustment of motor parameters, such as speed, torque, and direction, is made possible by motor control via static power converters. Static power converters enable for flexible voltage and frequency supply to the motor, enabling effective and specialized motor control. Numerous sectors use this method extensively, which helps to increase automation, performance, and energy efficiency.

**Static Converters:**Using solid-state components including power transistors, diodes, and thyristors, a static power converter, also referred to as a solid-state power converter, is an electronic device that transforms electrical power from one form to another. To effectively manage and convert electrical power, it is frequently utilized in a variety of applications. Power electronics and electrical systems frequently use static power converters to carry out operations like voltage conversion, frequency conversion, and power factor correction. They are superior to conventional electromechanical power converters in a number of ways, including efficiency, response time, and compactness. Voltage conversion is one of the main purposes of a static power converter. Direct current (DC) voltage can be converted from alternating current (AC) voltage or the other way around. Rectifiers are frequently used for converting AC to DC, whilst inverters are used for converting DC to AC. Static power converters can produce accurate and efficient voltage conversion by managing the switching of semiconductor devices like diodes and transistors. Another crucial capability of static power converters is frequency conversion.

They have the ability to change the frequency of electrical power, allowing for interoperability between various power systems or altering the frequency for particular uses. In industrial contexts, renewable energy systems, and motor driving applications, frequency converters are frequently employed. Power factor correction (PFC) also heavily relies on static power converters. Power factor is a measurement of how effectively a load uses electrical power. Reactive power is reduced as part of power factor correction approaches, which also aim to raise the power factor close to unity. To obtain high power factor and increase the effectiveness of power distribution systems, static power converters are utilized, such as active power factor correction (APFC) circuits. Motor drives are a significant additional use for static power converters. Static power converters are used by motor drives to regulate the speed, torque, and direction of electric motors. Static power converters provide you precise control over how much voltage and frequency is delivered to the motor.

This is important across a range of sectors, including HVAC systems, electric vehicles, robotics, and automation. Static power converters are also used in wind and solar photovoltaic (PV) power systems, among other renewable energy sources. They are used to transform DC power produced by solar or wind turbines into AC power suitable for local or grid integration. Static power converters allow for effective power extraction, tracking of the highest power point, and grid synchronization. Static power converters are electronic devices that use solid-state components

to transform electrical power from one form to another. They are crucial in power electronics, motor drives, renewable energy systems, and a variety of other applications because they provide effective and accurate control over voltage, frequency, and power factor. Modern electrical systems rely heavily on static power converters, which help to increase power quality, system control, and energy efficiency.

**Importance of Motor Control:** Due to its profound influence on effectiveness, safety, and performance, motor control is of highest importance in a variety of areas and businesses. The following are some major justifications for the significance of motor control:

- a. **Efficiency in Terms of Energy Use:** Good motor control helps reduce energy use. Motor control systems can make sure that motors are operating at their most effective levels by controlling motor speed, torque, and power output. As a result, there is less energy wasted, less money spent on operations, and greater overall energy efficiency.
- b. **Process Control:** Motor control is essential for process control in industrial applications. Machines and equipment are frequently powered by motors, and careful management of the motor's characteristics ensures that operations are carried out precisely and consistently. This improves the efficiency, dependability, and quality of the manufacturing and production operations.
- c. **Safety:** In many applications, motor control systems help to ensure safety. Motor control systems can avoid hazardous conditions like motor overheating, overloading, or excessive current draw by applying the proper control mechanisms. Additionally, motor control systems make it possible to include safety measures like motor protection systems or emergency stop capability.
- d. **Speed and Position Control:** Controlling motor speed and position precisely is necessary for many applications. For instance, precise motor movement control is crucial in automated systems, robotics, and CNC machines. Improved accuracy, repeatability, and control over complicated motion sequences are possible thanks to motor control systems, which frequently work in conjunction with feedback sensors to offer accurate speed and position control.
- e. **Variable Speed Control:** Variable speed operation is made possible via motor control, which has a number of advantageous applications. The system or piece of equipment can adjust to shifting operating needs by regulating motor speed. Improved process control, lessened mechanical stress, improved system response, and energy savings are just a few benefits of variable speed control.
- f. **System Integration:** The integration of numerous subsystems and components in complex systems depends on motor control systems. Motor control enables smooth system performance and seamless communication between various system components by efficiently coordinating motor actions with other system components.
- g. **Noise Reduction:** Motor control strategies can assist lessen the noise that motors make when they are operating. Noise levels can be reduced, resulting in quieter operation in applications where noise is a concern, by improving motor control parameters and putting PWM (Pulse Width Modulation) control techniques into practice.



**h. Maintenance and Reliability:** Improvements in maintenance and dependability can be made by properly implementing motor control systems. Motor control systems may increase the life of motors, decrease downtime, and improve overall system reliability by monitoring motor performance, spotting anomalies, and putting preventative maintenance procedures in place.

Motor control is crucial for maximizing system performance, assuring safety, enabling precise control, and attaining energy efficiency. Motor control is a crucial component that has a substantial impact on efficiency, productivity, and dependability in a variety of applications, including transportation, robotics, and HVAC systems.

## DISCUSSION

**Overview of Static Power Converter:** Electronic devices that make it easier to convert and control electrical power are known as static power converters, also referred to as solid-state power converters. In numerous applications, including as power electronics, motor control, renewable energy systems, and industrial automation, they are essential. In comparison to conventional electromechanical devices, static power converters provide advantages such as high efficiency, quick reaction, accurate control, and compact size. Static power converters' primary job is to transform one type of electrical power into another while preserving the desired properties of voltage, current, and frequency. They are employed for activities including voltage conversion, frequency conversion, power factor adjustment, and enhancement of power quality. The following are a few of the most popular kinds of static power converters:

a. **Rectifiers:** Static power converters that change AC (alternating current) electricity into DC (direct current) power are known as rectifiers. They are frequently found in the power sources for many different electrical systems and devices. Depending on how the rectification circuit is set up, rectifiers can be either half-wave or full-wave rectifiers.

b. **Inverters:** By turning DC power into AC power, inverters serve the opposite purpose of rectifiers. In systems like motor drives, renewable energy sources, and uninterruptible power supply (UPS), they are crucial. Motor speed, power flow, and grid compatibility can all be precisely controlled with the use of inverters, which produce AC power with variable voltage and frequency.

c. **AC/DC Converters:** AC/DC converters, sometimes referred to as power supplies or AC-to-DC converters, transform AC power into regulated DC power. To supply the required DC voltage for electronic devices to operate, they are frequently utilized in those devices. Different topologies, including as flyback, forward, and buck-boost converters, can be used with AC/DC converters[3]–[5].

d. **DC/DC Converters:** DC/DC converters enable voltage step-up or step-down operations by converting DC power from one voltage level to another. They are used in processes including voltage control, DC power distribution, and battery charging. The topologies of buck, boost, buck-boost, and flyback converters are frequently used DC/DC converters.

e. **Cycloconverters:** Cycloconverters are specialized static power converters that offer direct frequency conversion without a prior DC step. They are excellent for applications like variable-speed motor control, induction heating, and adjustable speed drives because they can convert AC electricity from one frequency to another.

To carry out the power conversion and control operations, static power converters use a variety of semiconductor components, including diodes, transistors, thyristors, and integrated circuits. To produce the necessary power output, these devices are managed utilizing pulse-width modulation (PWM) strategies and complex control algorithms. Static power converters enable accurate and efficient power conversion, which is essential for modern power systems and electronic equipment. Power electronics technology has advanced as a result of their broad use in a variety of applications, which has increased system control, performance, and energy efficiency.

**Rectifiers in Motor Control:** Rectifiers are essential components of motor control systems, especially when an alternating current (AC) source is used to power the motor. An electrical device called a rectifier change alternating current (AC) power into direct current (DC) power. Rectifiers are used in motor control to deliver the proper DC voltage and current to run the motor efficiently. A rectifier's principal job in motor control is to change the AC electricity coming from the power source or the mains into a DC voltage that the motor can use. Diodes in the rectifier circuit only permit one direction of current flow. The diodes conduct and permit current to flow when the AC voltage is positive, but they block it when the AC voltage is negative. Half-wave, full-wave, and bridge rectifiers are some of the numerous rectifier topologies that are utilized in motor control.

a. **Half-Wave Rectifiers:** A half-wave rectifier is a device that uses a single diode to carry current during the positive half of an AC voltage cycle while blocking it during the negative half. Despite their straightforward construction, half-wave rectifiers are not widely used in motor control due to their poor efficiency and large output harmonic content.

b. **Full-Wave Rectifiers:** Full-wave rectifiers correct both the positive and negative half-cycles of the AC voltage using a combination of diodes. The full-wave bridge rectifier, which uses four diodes placed in a bridge configuration, is the most popular configuration. In comparison to half-wave rectifiers, the bridge rectifier offers a smoother DC output and enables more effective AC power usage.

c. **Bridge rectifiers:** Due to their greater efficiency and improved output characteristics, bridge rectifiers are frequently utilized in motor control systems. They are made up of a group of four diodes coupled in a bridge configuration, allowing current to flow through the load in just one direction. For dependable motor running, bridge rectifiers offer a DC output voltage that is steadier and smoother.

The rectified DC voltage is frequently further controlled and filtered in motor control applications to guarantee a reliable and appropriate power supply for the motor. In order to adjust the motor speed and torque, voltage regulation may need extra parts like voltage regulators or pulse-width modulation (PWM) systems. In general, rectifiers are essential for motor control because they convert AC power into DC power, which provides the voltage and current needed to operate the motor successfully. The selection of the rectifier arrangement is based on the power needs for the particular application, output characteristics, and efficiency standards.

**Inverters in Motor Control:** Since they act as the connection between the power source and the motor, inverters are essential components of motor control systems. An electronic device known as an inverter transforms direct current (DC) electricity into alternating current (AC) power, enabling precise control of the motor's speed, torque, and rotational direction. Inverters are

frequently utilized with three-phase AC induction motors or brushless DC motors in motor control applications. An inverter's main job in motor control is to produce the necessary AC voltage and frequency to power the motor. The inverter transforms DC power into a variable-frequency, variable-voltage AC output that meets the needs of the motor by taking the DC power from a power source, such as a battery or a rectified AC source. The inverter can regulate the motor's speed and torque by adjusting the AC output's frequency and voltage. Inverters of various varieties, such as voltage source inverters (VSI) and current source inverters (CSI), are used in motor control. The most popular kind of inverter, voltage source inverters are frequently utilized in motor control applications. To produce the AC output voltage, they use power electronic switches such metal-oxide semiconductor field-effect transistors (MOSFETs) or insulated gate bipolar transistors (IGBTs). To produce the desired output voltage and frequency, these devices use pulse width modulation (PWM) techniques to control switching. Inverters offer a number of benefits in motor control applications.

- a. **Speed and torque control:** Control of the motor's speed and torque is possible with the help of inverters. The inverter may control the rotational speed and torque characteristics of the motor by modifying the frequency and voltage of the AC output. This makes it possible to have effective and adaptable motor control, which facilitates fluid acceleration, deceleration, and dynamic reaction.
- b. **Direction control:** Controlling the motor's direction is made possible via inverters. It is simple to alter the motor's rotational direction by flipping the phases of the AC output. This is crucial for applications requiring reversible motion, such as conveyor systems and robotics.
- c. **Energy effectiveness:** Inverters assist in making motor control systems more energy efficient. The inverter can match the motor's power requirements to the load demand by adjusting output voltage and frequency. This enables the most efficient motor running while minimizing energy losses, which saves energy and lowers operating expenses.
- d. **Soft starting and stopping:** Inverters make it possible for motors to start and stop smoothly. The inverter can give a soft start and stop, reducing mechanical stress on the motor and related equipment, by gently adjusting the frequency and voltage. This function is especially useful in applications where abrupt changes in speed may result in damage or disruption.
- e. **Diagnostic and protection features:** Inverters frequently have cutting-edge diagnostic and protection functions to guarantee dependable motor operation. Overload protection, overvoltage and undervoltage protection, short-circuit protection, and thermal protection are some of these features. The inverter keeps an eye on a number of variables and circumstances, enabling early defect identification and avoiding harm to both the inverter and the motor.

To sum up, inverters transform DC power into variable-frequency, variable-voltage AC power, which is crucial for motor control systems. They offer precise control over motor torque, speed, and rotational direction, allowing for effective and adaptable motor operation. Modern motor control applications require inverters as they offer benefits including energy economy, soft starting and stopping, and diagnostic and protective features.

**Choppers in Motor Control:** Electronic components called choppers, commonly referred to as DC-DC converters, are frequently employed in motor control systems. They are used to precisely control motor speed, torque, and direction by regulating the voltage or current provided to DC motors. Choppers are especially useful in situations where speed control, energy efficiency, and dynamic responsiveness are essential. A chopper's basic operation entails quickly turning on and off the motor's input voltage. The average voltage or current provided to the motor can be changed by adjusting the duty cycle, which is the ratio of the ON time to the overall switching duration. Pulse width modulation (PWM) is the name of this method.

In motor control applications, choppers have a number of benefits:

- a. **Speed control:** The effective voltage provided to the motor can be changed by varying the duty cycle of the chopper. This makes it possible to control the motor's speed precisely. The chopper can quickly switch between delivering full voltage and no voltage by adjusting the duty cycle, which enables effective control of the motor's rotational speed.
- b. **Torque Control:** Choppers also make it easier for DC motors to manage their torque. The torque output of the motor can be changed by adjusting the average current provided to it. This is especially helpful in situations like robotic systems or industrial automation where accurate torque control is necessary.
- c. **Regenerative Braking:** Choppers can make motor control systems capable of regenerative braking. The motor's kinetic energy is transformed back into electrical energy during braking and sent back into the power source. By switching the motor to function as a generator, choppers make this possible by enabling the energy to be efficiently recovered and utilised once more.
- d. **Energy Efficiency:** In motor control applications, choppers increase energy efficiency. The chopper lessens needless power dissipation by adjusting the average voltage or current provided to the motor. This is significant in applications like electric vehicles or renewable energy systems where energy conservation is essential.
- e. **Motor Bidirectional Control:** Choppers give the motor bidirectional control. The motor can be used in both forward and reverse motion by switching the polarity of the applied voltage. This makes it possible to precisely control the motor's direction of rotation, making it appropriate for uses like robots or electric vehicles [6]–[8].

Depending on the particular needs of the motor control system, choppers can be implemented using a variety of topologies, such as buck converters, boost converters, or buck-boost converters. The desired voltage or current range, the constraints of the power supply, and the characteristics of the motor all play a role in the selection of the chopper topology. DC-DC converters, often known as choppers, are crucial parts of motor control systems. By controlling the average voltage or current provided to the motor, they make it possible to precisely control the motor's speed, torque, and direction. Choppers have benefitted such regenerative braking, energy economy, speed and torque control, and bidirectional control. They play a crucial role in a number of applications, including as electric vehicles, industrial automation, and renewable energy systems, thanks to their adaptability and efficiency.

**Control Strategies for Motor Control:** In motor control systems, control techniques are essential for the precise and effective regulation of motor speed, torque, and other performance

---

parameters. Depending on the type of motor, the needs of the application, and the intended performance characteristics, different control techniques are used. We'll go through a few of the most popular motor control techniques in this part.

- a. **Proportional-Integral-Derivative (PID) Control:** PID control, also known as proportional-integral-derivative control, is a common control approach in motor control systems. In order to obtain the required motor response, it continuously modifies the control variables, particularly the proportional, integral, and derivative terms. A control action proportionate to the discrepancy between the desired and actual motor behavior is provided by the proportional term. By integrating the mistake across time, the integral term aids in the elimination of steady-state errors. By taking into account the error's rate of evolution, the derivative term foresees potential errors. Motor performance can be optimized in terms of response time, steady-state error, and stability by adjusting the PID controller gains.
- b. **Field-Oriented Control (FOC):** Also known as vector control, field-oriented control is frequently used to control AC motors, notably induction motors and permanent magnet synchronous motors. The magnetic field of the motor is separated by FOC into the orthogonal components of flux and torque. Motor speed and torque can be precisely controlled by managing these parts separately. FOC needs precise data on the location and speed of the rotors, which is often collected via rotor position sensors or senseless methods based on motor models and current measurements. High dynamic responsiveness, effective torque generation, and better motor performance are all provided by FOC.
- c. **Direct Torque Control (DTC):** Another well-liked control method for AC motors is direct torque control (DTC), which is renowned for its quick dynamic response and precise torque control. Without the use of coordinate transformations, DTC directly controls the flux and torque of the motor. Based on the intended torque and flux values, the best voltage vector is chosen using a look-up table or hysteresis controllers. In order to achieve the desired torque and flux, DTC uses a predictive algorithm that predicts the future motor state based on the current motor state and determines the necessary voltage vectors. High torque and flux control precision, low current ripple, and quick torque response are all features of DTC.
- d. **Model Predictive Control (MPC):** Model Predictive Control (MPC) is an advanced control technique that predicts future behavior and optimizes control actions by using a dynamic model of the motor and system limitations. MPC takes a finite prediction horizon into account and optimizes control inputs over this horizon while taking into account performance goals, system limits, and restrictions on motor variables. At each control interval, the control action is calculated by resolving an optimization problem. Excellent tracking precision, robustness to system changes, and adroit constraint management are all features of MPC. However, real-time optimization methods and computer resources are needed for MPC implementation.
- e. **Sliding Mode Control (SMC):** Sliding Mode Control (SMC) is a reliable control technique that is especially useful for addressing ambiguities, disturbances, and nonlinearities in motor control systems. In order for the system dynamics to function properly, SMC develops a sliding surface. To maintain the system state on the sliding surface and ensure resilience against uncertainties, the control action is created. Fast response times, insensitivity to



parameter changes, and robustness against outside disturbances are all features of SMC. But it might result in high switching frequencies and ensuing power losses.

- f. **Adaptive Control:** Adaptive control techniques dynamically modify the control parameters in response to changes in the system parameters and operating circumstances of the motor. In order to adjust to changes in the motor and system characteristics, adaptive control algorithms continuously update the control gains or other control parameters. In the presence of parameter uncertainties, changes in the load, and fluctuations in the parameters, adaptive control approaches can enhance the control performance. They offer greater tracking stability and precision under a variety of operational circumstances.
- g. **Hysteresis Control:** For some motor control applications, notably in position control systems, hysteresis control provides a straightforward but effective control method. In order to generate control signals, it makes use of a hysteresis comparator that calculates the difference between the desired and actual location. The control signal modifies, causing the motor to move, when the error rises above a predefined threshold (hysteresis band). Excellent tracking precision, quick response times, and insensitivity to parameter changes are all features of hysteresis control. However, frequent switching could result in increased noise and wear.

These are but a few illustrations of the control techniques applied in motor control systems. The type of motor, application requirements, system limitations, and desired performance characteristics all affect the choice of a particular control approach. To choose the best control approach and fine-tune the control settings to get the best motor performance, one must have a full understanding of the dynamics of the motor and the control objectives.

**Industrial Application of Motor Control by Static Converter:** Strict control of motor speed, torque, and other performance characteristics is made possible by the widespread use of static power converters in a variety of industrial industries. Numerous advantages of using static power converters include increased energy economy, higher system stability, and compatibility with various motor types. Let's look at some industrial uses for static power converters that are crucial for motor control:

- a. **Manufacturing and Industrial Automation:** Static power converter-based motor control systems are widely used in manufacturing and industrial automation. Conveyor belts, robot arms, pumps, fans, and other machinery utilized in production operations may all be controlled precisely thanks to them. Static power converters increase productivity and save energy consumption by adjusting motor speed and torque to provide precise placement, fluid movement, and efficient operation.
- b. **Electric Hybrid Vehicles:** There has been a noticeable shift toward electric and hybrid vehicles in the automobile sector. These cars' propulsion systems depend on static power converters to effectively control motor speed, torque, and regenerative braking. Motor control systems in electric and hybrid vehicles give higher performance, increased range, and increased energy efficiency by utilizing inverters, choppers, and other static power converter technologies.
- c. **HVAC Systems:** For accurate control of fans, pumps, and compressors, Heating, Ventilation, and Air Conditioning (HVAC) systems rely on motor control using static power

converters. In order to reduce energy consumption and improve comfort in commercial and residential buildings, static power converters enable the adjustment of motor speed and torque based on the temperature and load requirements. Additionally, static power converters enable sophisticated control features like variable refrigerant flow (VRF) systems, which give various indoor units individually adjustable control.

- d. **Renewable Energy Systems:** For effective power conversion and grid integration, renewable energy systems, such as wind turbines and solar power plants, use motor control using static power converters. In order to extract the most energy possible from renewable sources and maintain a stable grid, static power converters allow for the regulation of generator speed, pitch angle, and power factor. Static power converters provide smooth integration of renewable energy into the electrical grid by utilizing rectifiers and inverters, which helps to produce energy that is cleaner and more sustainably.
- e. **Robotics and Industrial Machinery:** Static power converters are essential for controlling the motors in industrial machinery and robotics, among other applications. Accurate movement, manipulation, and assembly tasks require precise motor control, which is largely reliant on in robotic systems. For robotic joints and actuators, static power converters offer the essential control mechanisms, ensuring smooth and accurate motion control. The use of motor control via static power converters helps industrial machinery like CNCs, printing presses, and textile machines reach high levels of precision, productivity, and energy efficiency.
- f. **Aerospace Systems:** Static power converters are used for motor control in a variety of aerospace applications, including as airplanes, satellites, and unmanned aerial vehicles (UAVs). Motor control systems based on static power converters offer dependable and efficient operation for everything from landing gear and flight control surfaces to fuel pumps and auxiliary systems. In order to ensure optimal performance, safety, and mission success in aircraft operations, they provide precise control of motor speed and torque.
- g. **Household Appliances:** A variety of household appliances, including washing machines, refrigerators, dishwashers, and vacuum cleaners, use static power converters to regulate the motor. Static power converters enable effective control of motor speed, agitation, and other parameters, improving home appliance performance while lowering noise levels and improving energy efficiency.

These are only a few instances of the industrial settings where the usage of static power converters for motor control is widespread. Static power converters' adaptability, effectiveness, and sophisticated control capabilities support better functionality, energy savings, and performance across a range of industries, spurring invention and progress in motor control technology[9], [10].

### **Advantages and Limitations of Static Power Converter**

#### **Static power converter benefits:**

- a. **High Energy Efficiency:** Static power converters in motor control applications give high energy efficiency. By carefully modifying the motor's operational characteristics and controlling the power flow, they reduce energy losses. As a result, the system becomes more efficient overall and uses less energy.

- b. **Controlling Motor Speed and Torque Accurately:** Static power converters make it possible to precisely control motor speed and torque. Static power converters enable fine-tuning of motor behavior, resulting in accurate operation and greater performance by altering the voltage and frequency provided to the motor.
- c. **Compatibility with Different Motor Types:** Static power converters are compatible with a variety of motor types, including synchronous motors, DC motors, induction motors, and others. Because of their adaptability, static power converters can be employed in a variety of industrial applications, regardless of the type of motor technology.
- d. **Advanced Control Features:** Static power converters are equipped with advanced control features including regenerative braking, which lets you recover energy lost during braking and acceleration. Other capabilities include the ability to use sophisticated control algorithms to enhance system performance, fault diagnostics, overcurrent protection, and these.
- e. **Reduced Maintenance Needs:** Static power converters contain fewer mechanical components than conventional control systems, which results in lower maintenance needs. They reduce damage and increase the dependability of motor control systems by doing away with the requirement for mechanical starters and contactors.
- f. **Improved System Stability:** Static power converters make systems more stable by delivering power to the motor in a smooth and reliable manner. By reducing problems like voltage variations, harmonics, and power factor distortions, they contribute to steady and dependable motor performance.

#### **Static power converter limitations:**

- a. **Complexity and Initial Cost:** Design and execution of static power converters can be complicated and expensive at first, requiring specialist knowledge. Static power converters may also cost more up front than conventional control methods, which could be a limiting issue for some applications.
- b. **Electromagnetic Interference (EMI):** Static power converters have the potential to produce electromagnetic interference (EMI), which could impair the functionality of nearby electronic equipment. To reduce EMI and guarantee electromagnetic compatibility with other equipment, appropriate shielding and filtering techniques must be used.
- c. **Harmonic Distortion:** Static power converters can introduce harmonic currents and voltages into the electrical system, causing harmonic distortion. These harmonics can lead to poor power quality problems such higher losses, voltage distortions, and equipment overheating. Harmonic filters should be used as mitigation strategies to deal with these distortions.
- d. **Cooling and Heat Dissipation:** Static power converters can produce heat while in use, especially at high power levels, hence cooling and heat dissipation are important. For the converters and related components to last a long time and to avoid overheating, adequate cooling systems or heat dissipation mechanisms must be in place.
- e. **Size and Weight:** Static power converters can be physically big and heavy, especially at higher power levels, necessitating proper installation space and structural considerations. This may be a problem in applications with weight or space constraints.

- f. **Limited Fault Tolerance:** The motor control system may be interrupted or shut down entirely in the event of a static power converter fault or failure. To improve system dependability and reduce downtime, appropriate protection mechanisms including fault detection circuits and redundant configurations should be put in place.

Static power converters have advantages over disadvantages in many motor control applications, despite these restrictions. Static power converters are becoming more efficient, dependable, and cost-effective for a variety of industrial applications thanks to ongoing developments in converter technology that continue to solve these limits.

## CONCLUSION

An overview of motor control using static power converters has been given in this study. A few benefits of static power converters include their high efficiency, ability to precisely manage motor speed and torque, and compatibility with a variety of motor types. In motor control applications, static power converters such as rectifiers, inverters, and choppers are frequently used. Each of these devices has distinct properties and control methods. When choosing and creating static power converters, it is crucial to take into account the unique needs and limitations of the motor system. To satisfy the changing needs of motor control systems, future research in this field should concentrate on improving control methods, increasing power conversion efficiency, and investigating novel converter topologies. Engineers and researchers will be able to design effective and dependable motor control solutions for a variety of industrial applications with the help of the knowledge gathered from this study.

## REFERENCES:

- [1] M. A. Perez, S. Ceballos, G. Konstantinou, J. Pou, and R. P. Aguilera, "Modular Multilevel Converters: Recent Achievements and Challenges," *IEEE Open J. Ind. Electron. Soc.*, 2021, doi: 10.1109/OJIES.2021.3060791.
- [2] M. P. Kazmierkowski, "Modular Multilevel Converters: Analysis, Control, and Applications [Book News]," *IEEE Ind. Electron. Mag.*, 2020, doi: 10.1109/mie.2020.3008022.
- [3] D. Zouheyr, B. Lotfi, L. Thierry, and B. Abdelmadjid, "Grid Side Inverter Control for a Grid Connected Synchronous Generator Based Wind Turbine Experimental Emulator," *Eur. J. Electr. Eng.*, 2021, doi: 10.18280/ejee.230101.
- [4] S. Musumeci, F. Mandrile, V. Barba, and M. Palma, "Low-voltage gan fets in motor control application; issues and advantages: A review," *Energies*. 2021. doi: 10.3390/en14196378.
- [5] J. Linares-Flores, J. F. Guerrero-Castellanos, R. Lescas-Hernández, A. Hernández-Méndez, and R. Vázquez-Perales, "Angular speed control of an induction motor via a solar powered boost converter-voltage source inverter combination," *Energy*, 2019, doi: 10.1016/j.energy.2018.10.024.
- [6] D. Zouheyr, B. Lotfi, and B. Abdelmadjid, "Improved hardware implementation of a TSR based MPPT algorithm for a low cost connected wind turbine emulator under unbalanced wind speeds," *Energy*, 2021, doi: 10.1016/j.energy.2021.121039.

- [7] K. Kumar, R. Tiwari, P. V. Varaprasad, C. Babu, and K. J. Reddy, "Performance evaluation of fuel cell fed electric vehicle system with reconfigured quadratic boost converter," *Int. J. Hydrogen Energy*, 2021, doi: 10.1016/j.ijhydene.2020.11.272.
- [8] K. B. Tawfiq, M. N. Ibrahim, H. Rezk, E. E. El-Kholy, and P. Sergeant, "Mathematical modelling, analysis and control of a three to five-phase matrix converter for minimal switching losses," *Mathematics*, 2021, doi: 10.3390/math9010096.
- [9] H. Sekhavatmanesh, J. Rodrigues, C. L. Moreira, J. A. P. Lopes, and R. Cherkaoui, "Optimal Load Restoration in Active Distribution Networks Complying with Starting Transients of Induction Motors," *IEEE Trans. Smart Grid*, 2020, doi: 10.1109/TSG.2020.2985783.
- [10] C. Jibhakate, M. Chaudhari, and M. Renge, "A reduced switch AC-AC converter with the application of D-STATCOM and induction motor drive," *Electron.*, 2018, doi: 10.3390/electronics7070110.



## UNINTERRUPTIBLE POWER SUPPLIES FOR ELECTRICAL MACHINES

**Mr. Vesapogu Joshi\***

\*Associate Professor,  
Department of Electrical And Electronics Engineering,  
Presidency University, Bangalore, INDIA  
Email Id-joshimanohar@presidencyuniversity.in

---

### ABSTRACT:

*The chapter underlines the importance of Uninterruptible Power Supplies (UPS) in supplying electrical machinery in industrial settings with reliable, uninterrupted power. According to the investigation, UPS systems greatly improve electrical equipment performance and dependability while also decreasing downtime and guarding against potential damage from power outages. Uninterruptible Power Supplies (UPS) are essential for giving electrical machines consistent, uninterrupted power. The purpose of this article is to examine the value of UPS systems in industrial settings and how they affect the functioning of electrical machines. The study's major conclusions and ramifications are highlighted in the chapter.*

**KEYWORDS:** *Line Interactive UPS, Power Supply, Online UPS, Standby UPS, UPS System, Universal UPS.*

---

### INTRODUCTION

Uninterruptible Power Supplies (UPS) are made to offer backup power in the event of power outages or voltage swings. These systems are frequently employed across a number of industries to maintain the continuous operation of crucial machinery. In essence, a UPS system is a battery backup that, in the event of a power outage or other power issue, supplies electricity to the connected devices. We will examine the main characteristics and advantages of UPS systems in this article, as well as the various types of UPS technologies that are offered on the market. A UPS system's battery backup, surge protection, and voltage regulation are its main components. In the event of a power loss, the battery backup makes sure that the linked equipment is kept powered. The equipment is shielded from power surges brought on by lightning strikes or other power fluctuations thanks to surge protection. For sensitive machinery like computers, servers, and medical devices, voltage regulation helps to maintain a constant voltage level.

On sensitive loads in the electrical systems, power distortions such power interruptions, voltage sags and swells, voltage spikes, and voltage harmonics can have a detrimental effect. These delicate loads are given uninterrupted, dependable, and high-quality power using uninterruptible power supply (UPS) systems. Medical facilities, life support systems, data storage and computer systems, emergency equipment, telecommunications, industrial processing, and online management systems are among the applications of UPS systems. Particularly necessary in locations with frequent power fluctuations and outages are UPS systems. When there is a power loss, a UPS offers a backup power circuitry to supply critical systems. A UPS delivers consistent power to keep the crucial loads functioning in cases of brief power fluctuations or disturbed

voltage. A UPS supplies backup power during prolonged power outages to keep the systems functioning long enough for them to be gracefully shut down. The majority of UPS systems also reduce harmonic and line disturbances. In general, a perfect UPS should be able to give uninterruptible power while also offering the required power conditioning for the specific power application[1]–[3]. As a result, the perfect UPS should have the following characteristics: regulated sinusoidal output voltage with low total harmonic distortion (THD) independent from changes in the input voltage or in the load, on-line operation, which means there should be no delay when switching from normal to backup mode, low THD sinusoidal input current, and unity power factor, high reliability, high efficiency, low EMI and acoustic noise, electric isolation, low maintenance, low cost, and water resistance. It is obvious that no single setup can offer all of these advantages. Different UPS system configurations place more emphasis on some of the previously stated aspects. Figure 1 illustrates a typical UPS system given below-

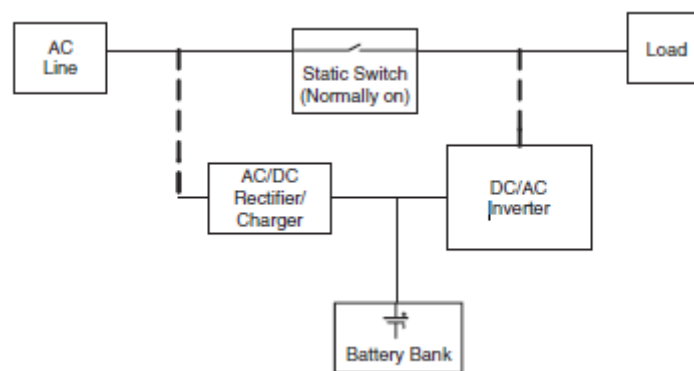

**Figure1: Configuration of a typical standby UPS system [Mdpi].**

**Advantages of UPS Systems:** Businesses and organisations can profit from UPS systems in a number of ways. A UPS system's primary advantage is that it guarantees the continuous operation of crucial equipment, which is crucial for companies that depend on technology to run their operations. UPS systems also guard against voltage fluctuations and power surges, which can seriously harm delicate equipment. Additionally, by supplying a steady power supply, UPS systems can increase the equipment's lifespan.

### **Different UPS Technology Types**

- a. The industry offers a variety of UPS technologies, such as standby, line-interactive, and online double-conversion. Different types of UPS systems provide differing degrees of efficiency and protection.
- b. The most basic form of UPS technology is the standby UPS. When the main power supply is cut off, it switches to battery power. The least amount of protection is offered by standby UPS systems, which are often less expensive than other types of UPS systems.
- c. A more sophisticated sort of UPS technology that offers better protection against power fluctuations is the line-interactive UPS. The line-interactive UPS regulates voltage via a transformer and offers battery backup in the event of a power outage.

**Online Double-Conversion UPS:** The most cutting-edge UPS technology is the online double-conversion UPS. It offers the best level of defence against voltage changes, power surges, and

power outages. A stable and reliable power supply is ensured by the online double-conversion UPS by converting AC power to DC power and then back to AC power.

## DISCUSSION

### Classification of UPS

**Standby UPS:** Uninterruptible Power Supply (UPS) systems, such as standby UPS, are frequently used in households, small businesses, and computers. Because the linked equipment is powered directly by AC mains power and the UPS only switches to battery power when the mains power fails, this type of UPS is also referred to as an offline UPS. The main characteristics, advantages, drawbacks, and ideal applications of standby UPS will all be covered in this article.

**Key Characteristics of Standby UPS:**A standby UPS's main characteristics are voltage management, surge protection, and battery backup. In the event of a power loss, the battery backup makes sure that the linked equipment is kept powered. The equipment is shielded from power surges brought on by lightning strikes or other power fluctuations thanks to surge protection. For sensitive machinery like computers, servers, and medical devices, voltage regulation helps to maintain a constant voltage level.

**Advantages of A Standby UPS:**Standby UPS has a number of advantages, including affordability, use, and dependability. The standby UPS is a common option for small enterprises and private use because it is reasonably priced when compared to other kinds of UPS systems. Additionally, it doesn't need any special wiring and is simple to install and use. For brief power outages, the standby UPS offers dependable backup power, shielding the connected devices from harm and data loss.

**The Drawbacks of Standby UPS:**Before selecting this kind of UPS system, standby UPS's restrictions must be taken into account. Only a little amount of backup power, typically between 5 and 15 minutes, is offered by the standby UPS. This is appropriate for brief power outages, but not for prolonged ones. There may be a small power outage while switching to battery power because it doesn't happen instantly. The connected equipment may nevertheless sustain damage despite the standby UPS's limited protection against power spikes and voltage fluctuations.

**The Best Applications for Standby UPS:**Small enterprises, residences, and personal PCs that need simple backup power protection should use standby UPS. It is also appropriate for non-critical equipment that can withstand a temporary power outage. For equipment like medical devices or data centres that needs a constant power supply, a standby UPS is not appropriate.

In summary, an economical and dependable Uninterruptible Power Supply (UPS) system is a standby UPS, which offers backup power protection during brief power outages. It is a popular option for small enterprises and personal use because it is simple to use and install. It does, however, have significant drawbacks, such as limited backup power, a temporary gap in power delivery, and insufficient protection against voltage fluctuations and power surges. The greatest candidates for standby UPS are non-critical devices that can withstand a brief power outage. It is not appropriate for sensitive applications or equipment that needs constant power supply.

**On-line UPS:** Online UPS is a sort of Uninterruptible electricity Supply (UPS) system that offers connected devices consistent, high-quality electricity. Because the incoming AC power is

first converted to DC power, which is subsequently utilised to charge the battery and power the attached equipment, this type of UPS is often referred to as a double-conversion UPS. In this post, we'll examine the main traits and advantages of online UPS, as well as its drawbacks and ideal applications.

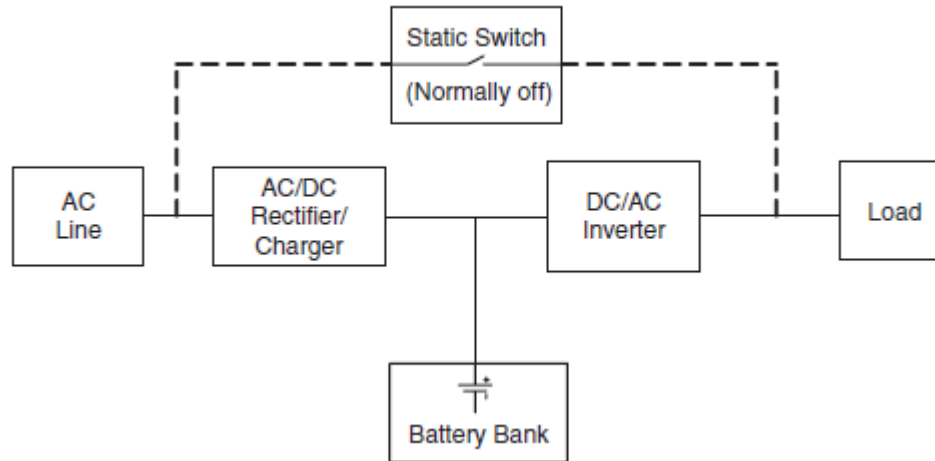

**Figure 2: Representing the Online UPS system [Mdpi].**

**Key Characteristics of Online UPS:**An online UPS's primary characteristics include isolated output, double conversion, and high-power efficiency. The double-conversion technique makes sure that the incoming AC power is converted to DC power first, which is then used to recharge the battery and power the attached devices Figure 2. The connected equipment receives a clean, reliable, and noise- and interference-free power supply from the isolated output. Due to the online UPS's excellent power efficiency, less energy is lost during conversion, which lowers energy expenses and lowers the environmental impact.

**Advantages of Online UPS:**Numerous advantages are provided by online UPS, including strong power quality, reliable power backup, and surge protection. The linked equipment is kept powered in the event of a power outage thanks to the continuous power supply provided by online UPS. The equipment is shielded against power surges brought on by lightning strikes or other power fluctuations thanks to the surge protection feature. For sensitive equipment like servers, medical devices, and laboratory equipment, a clean and consistent power supply is crucial, and the high-power quality of online UPS provides this.

**Online UPS's drawbacks:**Before selecting this kind of UPS system, it is important to take into account the limits of online UPS. In comparison to other types of UPS systems, the double-conversion technique employed in online UPS results in greater expenses. Increased energy use and heat production from online UPS's continuous operation may call for additional cooling systems. The performance of some equipment may be impacted by the online UPS's potential to generate some level of noise and interference into the power supply[4]–[6].

**Applications of Online UPS:**The best uses for online UPS are important applications like data centres, hospitals, and laboratories that need a consistent, high-quality power supply. It is also appropriate for machinery like telecommunications equipment and industrial machinery that needs voltage management and surge protection. For non-critical applications that can handle a

temporary power outage, an online UPS is not recommended because of the greater price and energy usage.

In summary, Critical applications can benefit from continuous power backup and surge protection provided by online UPS, a dependable and high-quality form of uninterruptible power supply (UPS) system. It makes use of double-conversion technology to guarantee a stable, clean, and noise- and interference-free power supply. However, it has several drawbacks, such as increased expenses, more energy usage, and higher heat generation. The best uses for online UPS are important applications like data centres, hospitals, and laboratories that need a consistent, high-quality power supply. It is not appropriate for non-critical applications that can endure a brief power outage.

**Line-interactive UPS:**An Uninterruptible Power Supply (UPS) system called a line-interactive UPS is made to offer connected equipment power backup and surge protection. Instead of relying on the battery backup, this kind of UPS system uses an automated voltage regulator (AVR) to regulate the incoming AC voltage and keep it within a safe range. In this post, we'll look at the main advantages and characteristics of line-interactive UPS, as well as some of its drawbacks and ideal applications.

**Important Properties of Line Interactive UPS:** Automatic voltage regulation, battery backup, and surge protection are among the essential characteristics of a line-interactive UPS. The AVR is used by the automatic voltage regulation feature to regulate the input AC voltage and maintain it within a safe range, protecting the connected equipment from power surges and voltage spikes. The connected equipment is kept powered in the event of a power outage thanks to the battery backup feature. The equipment is shielded against power surges brought on by lightning strikes or other power fluctuations thanks to the surge protection feature.

**Line-interactive UPS advantages include:**Voltage regulation, surge prevention, and dependable power backup are just a few advantages of line-interactive UPS. Automatic voltage control safeguards linked devices against damaging power surges and voltage spikes that could also result in data loss. In the event of a power outage, the battery backup feature makes sure that the connected equipment is kept powered, preventing downtime and data loss. The equipment's lifespan is increased by the surge protection mechanism, which shields it against power surges brought on by lightning strikes or other power irregularities.

**Line-interactive UPS restrictions:**Prior to selecting a line-interactive UPS system, one should be aware of its limitations. In situations when there are significant voltage fluctuations or brownouts, the automated voltage control mechanism could not work as intended, necessitating the use of the battery backup. There is a chance that the battery backup won't last long enough for some essential applications. The performance of some equipment may be impacted by the line-interactive UPS's potential to introduce some level of noise and interference into the power supply.

**The best applications for line-interactive UPS:**Small companies, home offices, and home entertainment systems are some of the applications that line-interactive UPS is most suited for. These applications also need reliable power backup and surge protection. It is also appropriate for devices like computers, servers, and networking hardware that need voltage regulation. Because the battery backup may only have a short runtime, line-interactive UPS is not appropriate for applications that need continuous power backup. Additionally, because the line-



interactive UPS may generate some level of noise and interference, it is not appropriate for applications that need a clean and reliable power supply.

In summary, an effective and dependable Uninterruptible Power Supply (UPS) system that offers linked equipment power backup, voltage regulation, and surge protection is called a line-interactive UPS. It does not need to rely on the battery backup since an automated voltage regulator (AVR) adjusts the incoming AC voltage and keeps it within a safe range. It does, however, have several drawbacks, such as a short runtime, poor performance under extreme voltage changes, and noise/interference. Small companies, home offices, and home entertainment systems are some of the applications that line-interactive UPS is most suited for. These applications also need reliable power backup and surge protection. It is not appropriate for applications that need a clean, consistent power source or continuous power backup.

**Universal UPS:** An Uninterruptible Power Supply (UPS) system known as a "universal UPS" is made to work with a variety of input voltages, frequencies, and output loads. In areas with low power quality, where input voltage and frequency might vary dramatically, this kind of UPS is frequently utilised. The main characteristics, advantages, drawbacks, and ideal applications of Universal UPS will all be covered in this article.

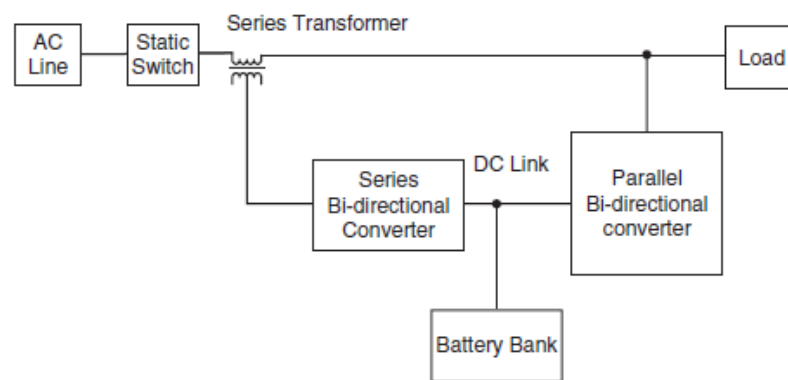

**Figure 3: Representing the Universal UPS [Semantic Scholar].**

**Key Characteristics of a Universal UPS:** Wide input voltage and frequency range, high efficiency, and adaptable output configuration are some of a Universal UPS's important characteristics. The wide input voltage and frequency range of the UPS enables it to function under a variety of input conditions, making it appropriate for usage in areas with poor power quality. The UPS's great efficiency aids in lowering energy usage and running expenses. The UPS may be set up to match the unique needs of the connected equipment thanks to its variable output configuration.

**Advantages of a Universal UPS:** High efficiency, dependable power backup, and compatibility with a broad range of input circumstances are just a few advantages that universal UPS offers. The UPS's excellent efficiency contributes to lower energy consumption and running expenses, which is crucial in areas with expensive or unstable electricity. In the event of a power outage, the dependable power backup feature makes sure that the connected equipment is kept powered, preventing downtime and data loss. The Universal UPS is appropriate for use in a number of applications, including data centres, industrial facilities, and distant locations due to its flexibility with a wide range of input circumstances.

**The drawbacks of Universal UPS:** Before selecting this kind of UPS system, it is important to take into account the restrictions of Universal UPS. Since other types of UPS systems may not offer the same level of voltage regulation due to the wide input voltage and frequency range, they might not be appropriate for applications requiring a high level of voltage stability. Because of its excellent output power efficiency, the UPS may not be appropriate for applications that call for great power density. Additionally, the Universal UPS could be more expensive and sophisticated than other types of UPS systems, making it unsuitable for small-scale applications.

**Ideal Applications for Universal UPS:** The applications that necessitate compatibility with a broad range of input circumstances, such as data centres, industrial facilities, and remote sites, are ideally suited for universal UPS. It is also appropriate for industries like telecommunications, healthcare, and financial services that demand high dependability and efficiency. Applications requiring a high level of voltage stability or high-power density are not suited for Universal UPS. Additionally, it is not appropriate for small-scale applications that call for a straightforward and affordable UPS solution.

An effective and dependable Uninterruptible Power Supply (UPS) system, the universal UPS is made to work with a variety of input voltages, frequencies, and output loads. High efficiency, dependable power backup, and compatibility with a wide range of input conditions are just a few advantages it provides. It does, however, have significant drawbacks, such as lower voltage stability, lower output power, and greater complexity and expense. The applications that call for compatibility with a broad range of input conditions, high efficiency, and reliability such as data centres, industrial facilities, and remote locations are ideally suited for universal UPS. Applications requiring a high level of voltage stability or high-power density are not appropriate for it.

**Applications of UPS:** There are several uses for UPS systems across numerous industries. Their typical uses range from low power ratings for desktop computers to medium power ratings for hospitals, life support systems, data storage, and emergency equipment to high power ratings for telecommunications, industrial processing, and online management systems. For these applications, certain factors need to be taken into account. The UPS should provide at least 90 minutes of backup for emergency lighting and systems. The UPS is intended to supply backup power to delicate loads for 15-20 minutes, excluding emergency systems. The system will then be gracefully shut down if the power is not restored by then. A bigger battery that costs more and takes up more space is needed if a longer backup period is taken into account. Some UPS systems are built to give process equipment and high-power applications adequate time to start up secondary power sources like diesel generators.

It should be mentioned that UPS systems increase the electrical system's complexity for industrial applications. They also increase the price of installation and ongoing maintenance. They might also make the system more non-linear, reduce its effectiveness, and damage the input PFC mechanism. The power rating of the UPS should be properly chosen taking into account the current load and any potential extensions. In many applications, surges and spikes in the input voltage are more harmful than power outages. In place of a UPS, another device can be used with these systems. When choosing a UPS, load characteristics should also be taken into account. The inrush current, which can be 2.5 times the rated current for motor loads, should be taken into account[7]–[9].

The UPS with larger transient overloads is a good UPS for motor loads. The input current for non-linear loads, like switching power supplies, is not sinusoidal. The instantaneous current is therefore greater than the RMS current. When choosing a UPS, this large instantaneous current should be taken into account. To support sensitive loads in a power distribution network, two alternative strategies are used. Many different UPS units work in parallel to supply vital loads in a dispersed way, which is better suited for highly proliferating loads like medical equipment, data processing, and telecommunications. Flexible placement of UPS units creates a critical load network in the system. Figure 4 depicts a typical on-line distributed UPS system. The key benefits of distributed systems are their high degree of flexibility and redundancy. The addition of additional UPS systems can sustain an increase in individual load. It is also possible to put off thinking about potential extensions until the loads are added. However, there are significant drawbacks to this approach.

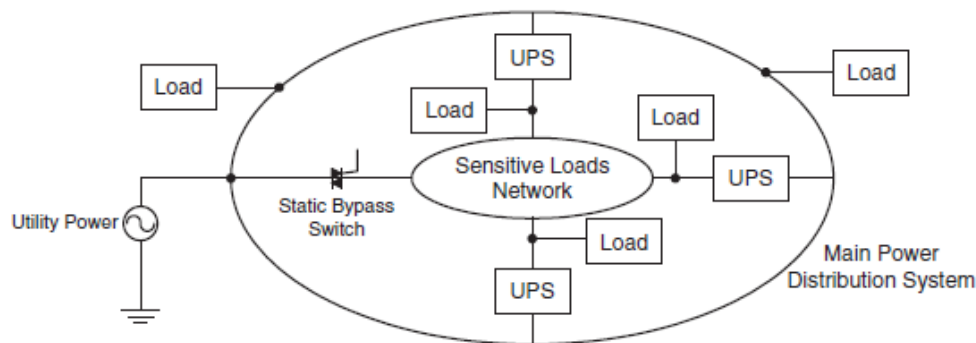

**Figure 4: Typical configuration of a distributed UPS network [Research Gate.Net].**

It can be challenging to divide up the load among different UPS units. To achieve the best load sharing, complex digital control techniques and unit-to-unit communication are needed. The second drawback is that it is challenging and requires workers who have received specialised training to monitor the entire system. The other way to support scattered loads is to employ a sizable UPS unit to centrally supply all the critical loads. Applications in the industrial and utilities sectors might benefit more from this strategy. This approach has the benefit of being simpler to maintain and debug. On the other hand, the drawbacks include a lack of redundancy and hefty installation costs. Additionally, when choosing the initial UPS unit, consideration for system expansion should be made[10].

## CONCLUSION

The study underlines the importance of Uninterruptible Power Supplies (UPS) in supplying electrical machinery in industrial settings with reliable, uninterrupted power. According to the investigation, UPS systems greatly improve electrical equipment performance and dependability while also decreasing downtime and guarding against potential damage from power outages. The safety provided by UPS systems against power outages, voltage sags, surges, and other electrical anomalies comes from the use of cutting-edge technology including battery backup and voltage regulation. These systems provide as a link between the electrical machinery and the utility power source, enabling a smooth changeover during power outages and avoiding expensive production stoppages. Additionally, the study shows that UPS systems maintain constant voltage levels, frequency consistency, and waveform quality to not only secure electrical machines but

also maximize their performance. Increased efficiency, less equipment wear and tear, and longer electrical machine lifespans are all benefits of higher power quality. To assure continuous power supply, safeguard electrical equipment from power interruptions, and enhance performance, uninterruptible power supply deployment is crucial in industrial settings. The results of this study highlight how crucial UPS systems are for preserving output, cutting downtime, and enhancing overall operational effectiveness in industrial applications.

#### REFERENCES:

- [1] E. Elbouchikhi, Y. Amirat, G. Feld, M. Benbouzid, and Z. Zhou, "A lab-scale flywheel energy storage system: Control strategy and domestic applications," *Energies*, 2020, doi: 10.3390/en13030653.
- [2] R. Peña-Alzola, R. Sebastián, J. Quesada, and A. Colmenar, "Review of flywheel based energy storage systems," in *International Conference on Power Engineering, Energy and Electrical Drives*, 2011. doi: 10.1109/PowerEng.2011.6036455.
- [3] A. Makalesi, M. Avkıran, V. Gül, S. Şahin, and İ. Tanağardığıl, "Data Acquisition Module Design for Remote Monitoring of Uninterruptible Power Supply and Regression Models of Battery Life," *Avrupa Bilim ve Teknol. Derg.*, 2020.
- [4] E. K. Sato and A. Kawamura, "Design of an autonomous control for parallel-connected uninterruptible power supplies," *IEEJ Trans. Ind. Appl.*, 2006, doi: 10.1541/ieejias.126.444.
- [5] S. Karthikeyan, P. Krishna Prakash, K. Logesh Krishna, and V. Poovarasam, "Review on Powering an Automated Teller Machine using Vertical Axis Wind Turbine and Solar Energy," in *Proceedings - International Conference on Artificial Intelligence and Smart Systems, ICAIS 2021*, 2021. doi: 10.1109/ICAIS50930.2021.9395907.
- [6] R. P. Alzola and R. S. Fernández, "BATERÍAS ELECTROMECÁNICAS: VOLANTES DE INERCIA PARA EL ALMACENAMIENTO TEMPORAL DE ENERGÍA. (French)," *ELECTROMECHANICAL Batter. FLYWHEELS Tempor. ENERGY STORAGE.*, 2008.
- [7] R. F. Schiferl and C. M. Ong, "Six phase synchronous machine with AC and DC stator connections, Part II: Harmonic Studies and a Proposed Uninterruptible Power Supply Scheme," *IEEE Trans. Power Appar. Syst.*, 1983, doi: 10.1109/TPAS.1983.317675.
- [8] A. Ivanov, K. Kamberov, and B. Zlatev, "Development of a Hybrid Asynchronous Radial Electrical Machine," in *2020 12th Electrical Engineering Faculty Conference, BuleF 2020*, 2020. doi: 10.1109/BuleF51036.2020.9326049.
- [9] I. Takahashi and I. Andoh, "Development of Uninterruptible Power Supply Using Flywheel Energy Storage Techniques," *IEEJ Trans. Ind. Appl.*, 1992, doi: 10.1541/ieejias.112.877.
- [10] R. Liou and S. Sanders, "Integrated multiport conversion with rotating transformer," in *2019 IEEE International Electric Machines and Drives Conference, IEMDC 2019*, 2019. doi: 10.1109/IEMDC.2019.8785418.

## INTERPHASE POWER CONTROL OF ELECTRICAL MACHINES

**Mrs. Ramya\***

\*Assistant Professor

Department of Electrical And Electronics Engineering,  
Presidency University, Bangalore, INDIA  
Email Id-ramyak@presidencyuniversity.in

---

### ABSTRACT:

*An essential component of running electrical machines, interphase power control ensures dependable and efficient functioning. An overview of electrical machine interphase power control strategies is provided in this chapter. Voltage control, current control, and power factor management are only a few of the techniques presented for managing the power distribution among the various phases of the machine. Each technique's benefits and drawbacks are addressed, as well as how they affect the effectiveness and performance of machines. The application of interphase power regulation in several electrical machine types, including induction motors, synchronous machines, and brushless DC motors, is also explored in this chapter. Also addressed are the difficulties and potential avenues for future study in interphase power control.*

**KEYWORDS:** *Ac Transmission System, Fault Current Limiter, Interphase Power Controller, Power Flow Controller, Thyristor-Controlled Voltage Limiter.*

---

### INTRODUCTION

An essential component of running electrical machines, interphase power control ensures dependable and efficient functioning. By adjusting the power distribution among the machine's various phases, this control method can maximize the machine's performance. This study presents an overview of electrical machine interphase power control techniques, outlining various approaches and examining how they affect machine productivity and efficiency. Electrical equipment is utilized extensively in many industrial and domestic applications, including brushless DC motors, synchronous machines, and induction motors. To reduce losses, enhance power quality, and improve system performance generally, these machines must use electrical power effectively. Techniques for controlling interphase power provide a way to accomplish these goals. Voltage control is one of the main interphase power regulation strategies. It is feasible to control the power distribution and enhance performance by varying the voltage sent to the machine's various phases.

Phase angle control, which modifies the phase angle between voltages, and the usage of voltage regulators, which vary the amplitude of the voltage waveform, are two methods for controlling voltage. The efficiency of the machine can be increased by lowering losses and decreasing harmonic distortions using these techniques, which also enable fine-tuning of power distribution. Another method is current control, which aims to control the current that passes through each component of the machine. It is feasible to balance the power distribution among the phases and ensure efficient operation by carefully managing the current. Techniques for



controlling current include current regulators, which change the waveform's amplitude and phase, and current limiting methods, which stop excessive currents. Electrical machines can function better when the current is controlled effectively, especially in situations where load changes are common. Another crucial component of interphase power control is power factor management[1]–[3]. Power factor is a gauge of how efficiently a system uses electrical power. The reactive power component can be lowered by power factor management, improving power quality and minimizing losses.

Capacitors or active power factor correction circuits are examples of power factor correction approaches that can be used to adjust power factor. These techniques aid in preserving a power factor that is close to unity, improving performance and requiring less energy. Depending on the kind of electrical machine, different interphase power control techniques are used. For instance, voltage management techniques like voltage regulators are frequently employed in induction motors to optimize power distribution. To precisely control the current flow in synchronous machines, current control techniques like field-oriented control are frequently used. Techniques for power factor adjustment can be used in brushless DC motors to enhance power quality and effectiveness. Although interphase power control has many advantages, there are some restrictions and difficulties to take into account. One such problem is achieving optimal power distribution under various load levels. Electrical machines frequently work under dynamic load situations, and it can be difficult to adjust power control strategies to these changes. In addition, interphase power control is constantly concerned with reducing losses and guaranteeing stable operation. These issues and their solutions should be the main topics of future interphase power regulation research.

To increase the precision and responsiveness of power control systems, advanced control strategies, such as model predictive control or adaptive control, might be researched. Furthermore, intelligent and adaptive interphase power regulation systems can be made possible through the incorporation of artificial intelligence and machine learning algorithms. To sum up, interphase power regulation is essential for enhancing the efficiency of electrical machines. It is possible to increase machine productivity, boost power quality, and gain better control over machine operation by adjusting the power split between phases. These goals can be attained using strategies including voltage control, current control, and power factor management. However, there are obstacles that must be overcome, like adjusting power control strategies to various load scenarios and reducing losses. To improve interphase power control in electrical machines, future research should concentrate on improving already used methods, investigating novel control strategies, and utilizing cutting-edge technologies. By doing this, we can promote the development of effective and environmentally friendly electrical machine systems.

**Interphase Power Controller:**A power electronic device called the Interphase Power Controller (IPC) has attracted a lot of attention recently due to its capacity to regulate and optimize power flow in multi-terminal AC transmission lines. It gives the management of power transmission and the incorporation of renewable energy sources a flexible and effective solution. In this article, we'll examine the IPC's main functions, characteristics, uses, and benefits (Figure 1).

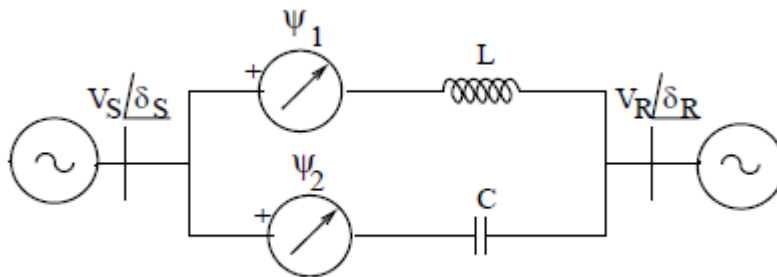

**Figure 1: Representing the IPC equivalent circuit [Brain Kart].**

**Working Principle:** In a multi-terminal AC transmission system, the IPC controls the voltage and phase angle between various phases or terminals. It comprises of manypowers electronic components, including control and monitoring systems and voltage source converters (VSCs) or thyristors. Depending on the requirements of the individual application, the IPC may be installed at different points in the transmission system. By regulating the voltage and phase angle difference between various phases or terminals, the IPC may regulate the power flow. It can manipulate or divert electricity within the transmission system by altering the connection between voltage and phase. In order to maximize power flow, the IPC continuously checks system characteristics including voltage, current, and frequency, and modifies its control parameters as necessary.

#### **Key Features of IPC:**

- a. **Power Flow Control:** The IPC offers fine control over power flow in multi-terminal AC transmission systems, which is one of its main features. It may distribute power as needed by adjusting the voltage and phase angle difference, allowing for effective use of the transmission infrastructure.
- b. **Voltage Regulation:** The IPC can control the transmission system's voltage levels. To maintain the correct voltage profiles and ensure proper voltage support and stability, it can alter the voltage magnitude and phase angle. The IPC has the ability to account for reactive power in the system. It may regulate the flow of reactive power to preserve voltage stability and power factor, increasing system effectiveness.
- c. **Fast and Dynamic Control:** The IPC provides these features. As a result, it can effectively control power flow and adapt to various operational settings. It can react fast to changes in system conditions.
- d. **Scalability and Modularity:** The IPC can be developed with a modular structure, enabling simple extension and scalability. IPC modules can be added or withdrawn following the needs of the system, allowing for future system upgrades and design flexibility.

#### **Applications of IPC:**

- a. **Renewable Energy Integration:** The IPC is essential for incorporating renewable energy resources into the grid, such as wind farms and solar power plants. By regulating power flow and

maintaining system stability, it makes it possible for efficient power transfer from these generation locations to load centers.

b. **Grid Interconnections:** The IPC enables effective power exchange between grids by facilitating the connecting of various AC transmission systems. Power may be transferred without interruption, and the stability and dependability of the grid are improved.

c. **Management of Transmission Networks:** The IPC can be used to manage transmission networks, particularly in systems with multiple terminals. It offers control over power distribution, voltage management, and reactive power compensation, allowing for effective use of the transmission network and enhanced system performance.

d. **Load balance:** The IPC can help with transmission system load balancing. It can distribute power among several terminals or phases, guaranteeing fair distribution and avoiding the overloading of particular network elements.

**Enhancement of Power System Stability:** By managing power flow and voltage levels, the IPC helps to maintain system stability. It promotes overall system stability, improves transient response, and helps reduce voltage fluctuations.

#### IPC Benefits Include

- a. **Enhanced Power Transfer Capability:** The IPC makes it possible for multi-terminal AC transmission systems to transfer power effectively, hence enhancing the system's overall power transfer capability. It enhances the usage of transmission infrastructure, maximizes power flow, and reduces transmission losses.
- b. **Increased System Stability:** The IPC increases system stability by controlling voltage levels and reactive power flow. It contributes to the maintenance of voltage profiles, power factors, and system performance as a whole, assuring dependable operation.
- c. **Greater Flexibility and Control:** The IPC offers greater control over power flow and flexibility in adjusting to shifting system conditions. It enables effective system operation by allowing for dynamic modifications and in-the-moment optimization.
- d. **Effective Renewable Energy Integration:** The grid integration of renewable energy sources is made possible by the IPC. It controls the flow of power from these sources, guaranteeing seamless integration and lessening the effect of intermittent power on the system as a whole.
- e. **Reduced Transmission Losses:** By streamlining electricity flow and easing network congestion, the IPC helps to reduce transmission losses. It increases the overall effectiveness of electricity transmission, resulting in financial savings and favorable effects on the environment [4]–[6].

#### Challenges and factors:

- a. **Control and Coordination:** The installation of IPC systems necessitates cooperation with other control devices in the power system and the use of sophisticated control algorithms. Effective operation depends on adequate synchronization and coordination between various IPC modules and control systems.

- b. **Harmonics and Power Quality:** The IPC's operation has the potential to cause voltage distortions and harmonics in the power system. To preserve power quality and adhere to regulatory requirements, proper filtering and mitigation measures must be used.
- c. **Voltage and Current Rating:** To manage the voltage and current levels in the transmission system, the IPC must be constructed and rated correctly. The system's capacity and potential overflow scenarios must be taken into account.
- d. **Expense and Implementation:** The installation of power electronic devices, control systems, and related infrastructure comes at a large expense when implementing IPC systems. IPC solutions' cost-effectiveness needs to be carefully assessed in light of the unique application requirements.
- e. **System Stability and Security:** To guarantee system stability and security, the control actions taken by the IPC should be carefully planned. To avoid instability, oscillations, or unwanted interactions with other system components, appropriate precautions must be taken.

The Multi-Terminal AC Transmission Systems offer enhanced power flow control capabilities through the Interphase Power Controller (IPC). The IPC makes efficient power transfer, voltage regulation, and reactive power compensation possible thanks to its capacity to regulate voltage and phase angle difference. It has uses in load balancing, transmission network management, grid interconnections, and renewable energy integration. The IPC has benefits like improved system stability, increased power transfer capability, flexibility, and effective use of transmission infrastructure. Control, harmonics, system stability, and cost issues, however, must all be carefully considered when putting IPC systems into place. The IPC can considerably contribute to the effective and dependable operation of multi-terminal AC transmission systems with correct design, coordination, and mitigation measures.

## DISCUSSION

**Initial concept of IPC:** The necessity for improved management and optimization of power flow in multi-terminal AC transmission systems led to the initial conception of the Interphase Power Controller (IPC). Traditional power transmission methods frequently use fixed power flow channels and have limited control options, which can result in wasteful use of transmission infrastructure and difficulties integrating renewable energy sources. To overcome these restrictions and offer a more adaptable and effective method of power flow control, the IPC was created. The idea of the IPC is to manipulate voltage and phase angle variations between various transmission system phases or terminals. The IPC can manage or redirect electricity by modifying these parameters, allowing for the best distribution of power flow and effective use of the transmission network. This control capacity enables dynamic modifications and real-time optimization, improving the transmission system's overall performance and dependability. Reactive power compensation and voltage regulation are additional elements included in the IPC idea.

The IPC contributes to system stability and guarantees proper voltage support across the transmission network by controlling voltage levels and reactive power flow. In multi-terminal systems where power is exchanged between various grids or generation sources, this capability is very crucial. The IPC paradigm also places a strong emphasis on modularity and scalability. The IPC may have a modular design that enables simple expansion and adaption to shifting system

requirements. According to the particular requirements of the transmission system, more IPC modules can be added or withdrawn, giving system designers flexibility for current and upcoming modifications. Providing improved power flow control capabilities in multi-terminal AC transmission systems was the main focus of the IPC's initial design. The IPC offers effective power transfer, voltage regulation, and reactive power compensation by adjusting voltage and phase angle differences. It solves the drawbacks of conventional power flow control techniques and creates opportunities for higher integration of renewable energy sources, better system performance, and optimal use of transmission infrastructure.

**Improvements in IPC:** Since its inception, the Interphase Power Controller (IPC) has experienced a great deal of development. Its performance, control abilities, efficiency, and applicability in diverse power system scenarios have all been improved. Some important advancements in IPC include:

- a. Enhanced Control Algorithms:** The IPC now has enhanced control algorithms that make it possible to control power flow more precisely and effectively. These algorithms dynamically correct voltage and phase angle disparities using real-time data and sophisticated optimization techniques to ensure the best possible power transfer and system stability.
- b. Multi-Objective Optimization:** Improved IPC systems now take into account numerous objectives, like minimizing transmission losses, maximizing power transfer efficiency, and preserving voltage stability. In order to determine the optimum trade-offs between these objectives, multi-objective optimization techniques are applied, leading to more effective and trustworthy power flow regulation.
- c. Integration with Wide-Area Monitoring Systems:** Wide-area monitoring systems, which offer real-time monitoring and analysis of system parameters across a large geographic region, have been integrated with IPC systems. The situational awareness of the IPC is improved by this integration, enabling proactive control measures and better system-wide coordination.
- d. Improved Capabilities for Communication and Coordination:** IPC systems now have better capacities for communication and coordination. They can communicate with other control devices, such as grid controllers and Flexible AC Transmission Systems (FACTS) devices, to enable coordinated control actions for the best regulation of power flow and system stability.
- e. Adaptive Control Strategies:** IPC systems have adaptive control techniques built in that can adjust to changing operational circumstances and system conditions. These techniques ensure efficient control even in dynamic contexts by dynamically adjusting control parameters based on real-time data and system dynamics.
- f. Integration of Energy Storage Systems:** In order to increase the capabilities of IPC systems, energy storage systems like batteries or supercapacitors have been combined with them. Energy storage systems can increase power flow control flexibility by enabling energy storage and release during times of high demand or abundant renewable energy production.
- g. Fault Detection and Self-Healing:** IPC systems that have been improved have capabilities for fault detection and self-healing. To restore system stability and reduce downtime, they



can immediately adjust the power flow when they discover system problems such as line failures or device malfunctions.

- h. Hardware Improvements:** The efficiency, power handling capacity, and reliability of IPC hardware components including power electronic devices and sensors have improved. These enhancements help IPC systems operate better overall and last longer.
- i. Integration with Smart Grid Technologies:** Integration of IPC Systems with Smart Grid Technologies Advanced metering infrastructure, demand response, and grid automation are just a few examples of the smart grid technologies that are being integrated with IPC systems. This integration improves the power system's overall efficiency and dependability by enabling better power flow monitoring, control, and coordination.
- j. Cost-cutting:** As IPC technology develops and use rises, there has been a focus on cutting costs across the board for IPC systems. Economical manufacturing techniques, cost-effective design strategies, and economies of scale have all helped to lower the cost and increase accessibility to IPC systems.

These advancements in IPC technology have improved power flow regulation, system stability, the integration of renewable energy sources, and the general efficiency of power transmission systems. The IPC is anticipated to continue advancing with continued research and development, enhancing its capabilities and broadening its uses in the power industry.

**Power characteristics of IPC:** Understanding an Interphase Power Controller's (IPC) power characteristics is essential for evaluating its performance in power transmission systems. The IPC demonstrates various essential power traits, such as:

- 1. Power Flow Control:** Controlling the flow of power in a multi-terminal AC transmission system is possible thanks to the IPC. Power can be allocated and directed as needed by the IPC by adjusting the voltage and phase angle discrepancies between phases or terminals, which optimizes power flow distribution and use.
- 2. Voltage Control:** The transmission system's voltage levels can be controlled by the IPC. In order to maintain the correct voltage profiles, it can change the voltage's magnitude and phase angle, providing the network with the proper voltage support and stability.
- 3. Compensation for Reactive Power:** The IPC has the ability to account for reactive power in the system. In order to keep the power factor and voltage stability, it can regulate the flow of reactive power. The IPC raises power quality and increases system efficiency by dynamically modifying reactive power flow.
- 4. Dynamic Control:** The IPC has quick control features that enable it to react quickly to modifications in system conditions. In order to maintain efficient power flow control and system stability, it can react to changes in load demand, renewable energy generation, and network topology.
- 5. Power Transfer Capability:** The IPC improves the multi-terminal AC transmission systems' ability to transfer power. It maximizes the use of the transmission infrastructure by streamlining power flow and lowering transmission losses, which raises the capacity and efficiency of power transfer.

6. **Power Quality Improvement:** The IPC helps to raise the transmission system's power quality. It ensures a steady and dependable supply of electrical energy by reducing voltage fluctuations, harmonics, and other power quality issues through voltage control and reactive power compensation.
7. **Power System Stability:** In order to improve the stability of the power system, the IPC is essential. In order to preserve system stability, alleviate voltage variations, and lower the danger of blackouts and system-wide problems, voltage levels are regulated together with reactive power management and power flow optimization.
8. **Flexibility in Control:** The IPC provides flexibility in controlling power flow based on unique operational needs. It can change how much electricity is distributed among various phases or terminals, allowing load balancing and avoiding overloading of particular network components.
9. **Scalability:** Modular and scalable architectures can be used to develop IPC systems. For flexibility in system design and potential upgrades, more IPC modules can be added or removed to accommodate modifications in system requirements or network extensions.
10. **Efficiency and Loss Reduction:** The IPC enhances overall system efficiency by optimizing power flow and lowering transmission losses. It reduces the amount of energy lost during long-distance power transmission, which has a positive impact on the environment and lowers costs.

To use the IPC in power transmission systems efficiently, it is crucial to comprehend these power characteristics. The IPC helps the effective, dependable, and long-lasting functioning of multi-terminal AC transmission systems by utilizing its power flow management, voltage regulation, and reactive power compensation capabilities.

**Fault Current Limiter:** During electrical faults, a Fault Current Limiter (FCL) is a device that is used in power systems to limit and control the magnitude of fault currents. Electrical problems happen when there is an abnormal flow of current, frequently as a result of a ground fault or short circuit. These flaws can seriously harm equipment, interfere with power flow, and provide safety risks. By bringing down the fault current to a safe and manageable level, FCLs aid in mitigating these problems. We shall examine the functions, varieties, uses, and advantages of fault current limiters in this post.

**Working Principle:** A fault current limiter's main job is to restrict current flow when there is a fault. It accomplishes this through some methods:

- a. **Resistance-based FCLs:** use resistors or other resistive components to restrict the fault current. The FCL decreases the current flow by adding a high resistance to the circuit when a fault occurs. To keep the current at a safe level, the resistance value is carefully chosen.
- b. **FCL based on reactance:** Inductors or reactors are used in reactance-based FCLs to add reactance to the circuit that has failed. The FCL decreases the amount of the fault current by raising reactance. The reactance value is intended to keep the current under control.
- c. **Superconducting FCLs:** These FCLs use the superconducting phenomena to restrict fault currents. At these temperatures, where some materials' electrical resistance almost

disappears, these devices' function. FCLs may successfully reduce fault currents to very low levels by using superconducting materials [7], [8].

#### **Fault current limiter types:**

- a. **Series Fault Current Limiter (SFCL):** A series connection is made between the power system and series fault current limiters, or SFCLs. They offer resistance to the fault current and control the amount of it. SFCLs are generally installed at the distribution level or the substation level.
- b. **Shunt Fault Current Limiter(ShFCL):** Parallel connections between Shunt Fault Current Limiters (ShFCLs) and the power system. They lessen the current magnitude by rerouting a portion of the fault current away from the faulty circuit. ShFCLs are frequently applied at the transmission level to safeguard crucial hardware and boost system dependability.
- c. **Hybrid Fault Current Limiter:** A hybrid fault current limiter combines the advantages of both series and shunt fault current limiters. To efficiently limit fault currents, they offer a mix of impedance and current diversion capabilities.

#### **Applications of Fault Current Limiters**

- a. **Power Systems Protection:** FCLs are generally employed to safeguard power system components from the destructive effects of fault currents, including transformers, generators, and transmission lines. FCLs help minimize equipment overheating, insulation breakage, and other defects downstream by controlling fault currents.
- b. **Renewable Energy Integration into the Grid:** The addition of renewable energy sources, such as wind and solar, to the electrical grid may provide problems with fault current levels. When producing grid-connected renewable energy, fault currents (FCLs) can be managed and controlled to ensure a safe and dependable operation.
- c. **Grid Interconnections:** In grid interconnections, where several power systems are coupled, FCLs play a crucial role. They assist in limiting the spread of fault currents across several networks, preventing cascading failures, and lessening the impact of disturbances.
- d. **Improvement of Power Quality:** FCLs can enhance power quality by lowering the voltage peaks and transients brought on by fault currents. FCLs help maintain stable voltage levels during fault conditions by reducing the size of fault currents, and minimizing disturbances to delicate equipment and loads.

#### **Fault Current Limiters' Advantages:**

- a. **Enhanced Equipment Protection:** By minimizing fault currents and avoiding undue strain on transformers, generators, and other components, FCLs effectively protect the equipment in the power system. This lowers maintenance expenses and helps equipment last longer.
- b. **Increased System Reliability:** FCLs improve the overall dependability of power systems by lowering fault currents. They lessen the possibility of machinery breakdowns, downtime, and power outages brought on by excessive fault current levels.
- c. **Greater Safety:** Individuals working on electrical systems are at risk of injury from fault currents. By limiting fault currents to safe levels and lowering the possibility of electrical shocks and accidents, FCLs contribute to the improvement of workplace safety.

- d. **Efficient system Integration:** FCLs make it possible for renewable energy sources to be seamlessly included in the electrical system. They manage and regulate fault currents, enabling greater penetration of renewable energy production without jeopardizing the security and stability of the system. By restricting fault currents during electrical faults, fault current limiters serve a critical function in power systems. They promote the integration of renewable energy sources, improve power quality, protect equipment, and increase system reliability. FCLs offer effective and efficient methods for regulating fault currents and guaranteeing the safe and dependable functioning of power systems by leveraging a variety of approaches like resistance, reactance, and superconductivity.

The fault levels rise as generation and system interconnections expand. The fault levels are further influenced by dynamic loads such as synchronous and induction motors. Circuit breakers (CB) have an interruption capability of less than 80 kA, and a common CB level is 63 kA. It is not a very practical approach to replace the switch gear to accommodate higher fault levels. Bus splitting, which can decrease dependability, and/or the use of reactors and high-impedance transformers are alternative methods. The latter is similarly undesirable because it has worse stability issues, voltage regulation issues, and greater losses. On-load tap changers can be omitted with the use of low-impedance transformers. Even when the breaker capacity is adequate, it is occasionally required to protect equipment against the destructive effects of fault currents. A transformer buried in a vault or wires that are exceedingly expensive to replace is two examples. Circuit breakers with quicker interrupting times have been developed to lessen the harmful effects of high fault currents. The number of clearing cycles has decreased from five to two or perhaps one. To interrupt the problem, however, all AC circuit breakers require a current zero passing.

To reduce the fault current magnitude to a relatively low predefined value, it would be ideal to interrupt or limit the fault current at a point considerably below its first peak. This is a highly challenging task because it calls for a response time of less than 2 milliseconds. Fault Current Limiters (FCL) come in two different varieties, and both are currently being developed. Which are:

1. HTS FCL, or high-temperature superconductor.
2. Solid State Current Limiter

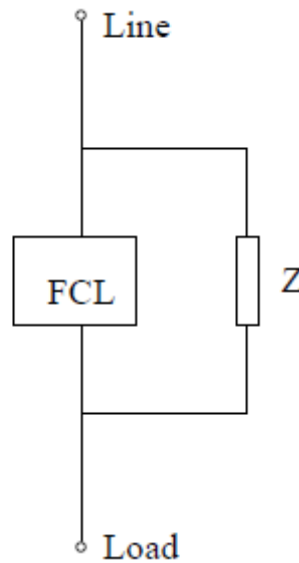

**Figure 2: Representing the Fault Current Limiter [Engineering lab].**

Economical FCL development is made possible by the 1986 creation of HTS. Unlike low-temperature superconductors (LTS), which are cooled by liquid helium, which is expensive and difficult to handle, the HTS requires cooling by liquid nitrogen at 77 K. Although prior FCL concepts built on LTS were researched more than 25 years ago, they were never put into practice. With the introduction of HTS, interest in superconducting fault current limiters (SFCL) has increased. A temperature as low as 85 K causes HTS materials like YBCO to completely lose all resistance. The needed current limiting impedance is introduced when the material transitions from its usual superconducting state to a resistive state when the current in it surpasses a critical level of the superconductor.

Normally, the critical current of a superconductor would be 2 or 3 times the current required to operate at full load. By forcing the majority of the fault current through a resistor or inductor, the superconductor can likewise be employed as a trigger coil in its resistive condition see Figure 2. This configuration has the benefit of reducing the amount of energy that the semiconductor must absorb. Under normal circumstances, the FCL is a short across the copper inductive or resistive element Z. The resistance developed in the limiter shunts the current through Z, which absorbs the majority of the energy, during a malfunction. Another idea is to put the primary transformer in series with the circuit and use a resistive limiter on the secondary. Figure 3 depicts the SFCL's first phase. In this case, the HTS winding is connected to a copper winding that has been introduced into the circuit. Throughout regular use, a zero impedance is transmitted to the main. The primary is reconnected to the HTS winding during a fault, which restricts the fault current. The benefits of an SFCL include:

1. **Passivity:** without active monitoring and control methods, fault detection, and current limiting impedance insertion.
2. **Transparency:** During steady-state operation, there are no significant  $I^2R$  losses or voltage drops across the device. To the grid, the SFCL is essentially undetectable.



3. **Modularity and Scalability:** To create the current limiting matrix, some fundamental current limiting modules are arranged in an  $m \times n$  matrix. The matrix's rows and columns are determined by the notion grid current level at which the FCL is attached and by the necessary current limiting impedance.
4. **Reliability:** Due to the matrix configuration, redundancy may be simply implemented duration.

Many nations, including the USA, Canada, France, Germany, and Japan, are attempting to create SFCL at EHV levels. By 2010, transmission-level SFCLs may be accessible.

**SSCL, or a Solid-State Current Limiter:** To reach a specific voltage rating, an SSCL is composed of numerous similar modules connected in series. A solid-state circuit module can be made up of GTO or traditional thyristor switches with a commutating circuit to stop the flow of current in the main circuit and direct it into a parallel-connected resistor. If the fault current is high, the circuit is built to detect it and start current limiting in a millisecond. This is comparable to how a current-limiting fuse works, which makes sure that the line never experiences the first current peak. Transmission class current limiters may go through field trials in 2008 as medium voltage current limiters are now undergoing development[9], [10].

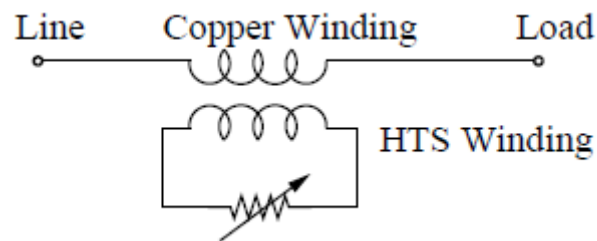

**Figure 3: Representing the Inductive SFCL [Research Gate.Net].**

An SSCL is anticipated to cost around six times as much as traditional mechanical circuit breakers and relays. If the thyristor switches are capable of interrupting at the first current zero, an SSCL can also function as a circuit breaker. Although GTO switches can stop current with hardly any delay, they have extremely little capacity for overload. By reducing the length and severity of the voltage sag, an SSCL can also enhance power quality for lines that are not defective.

**Thyristor-Controlled Voltage Limiter:** A power electronic device called a thyristor-controlled voltage limiter (TCVL) is used to control and limit voltage levels in electrical power systems. It is generally used as a safeguard against voltage disturbances such voltage sags, swells, and transients for sensitive equipment and gadgets. Thyristors are used by TCVLs to manage voltage levels by rerouting or absorbing extra power when the voltage rises above certain thresholds. The working theory, salient characteristics, practical uses, and advantages of TCVLs will all be covered in this article.

**Working Principle:** The TCVL regulates power flow in response to variations in voltage levels. It is made up of thyristor-based switching components that are coupled either in series with the power source or in parallel with the load. The thyristors are activated to conduct and deflect the surplus power away from the load or absorb it, so regulating the voltage, when the voltage rises over the desired limit.

Using voltage sensors, the TCVL continuously checks the system's voltage levels. The control mechanism instructs the thyristors to conduct or restrict current flow based on the detected voltage. The TCVL can adjust the voltage and confine it within the appropriate range by changing the conduction angle of the thyristors. The following are the main characteristics of TCVLs:

- a. **Voltage Regulation** TCVLs precisely regulate voltage by actively regulating the thyristors' conduction. They can keep the voltage within set parameters, ensuring the secure operation of delicate machinery.
- b. **Quick Reaction:** TCVLs provide quick reaction times to voltage perturbations. They have a short response time to voltage changes and can activate the thyristors to limit the voltage, protecting the linked electronics.
- c. **Changeable Voltage Limits:** TCVLs provide options for changeable voltage limits, giving them flexibility to meet various system needs. Based on the particular requirements of the connected equipment and the desired level of protection, the voltage restrictions can be defined.
- d. **High Current Carrying Capacity:** TCVLs are made to carry large amounts of current, which enables them to efficiently redirect or absorb extra power during voltage fluctuations. Even in high-power situations, this guarantees equipment protection.
- e. **Modularity and Scalability:** TCVLs can be created with a modular structure, allowing for easy integration into various power systems and scalability. TCVL modules can be added or withdrawn in accordance with the needs of the system, allowing for future system expansion and design flexibility.

#### **Applications of TCVL:**

- a. **Industrial Systems:** TCVLs have a wide range of applications in industrial systems, which require protection against voltage disturbances for sensitive equipment such as motors, drives, and control systems. They aid in preserving constant voltage levels, avoiding equipment breakdowns and downtime.
- b. **Grid Integration of Renewable Energy Sources:** TCVLs are essential for the grid's integration of renewable energy sources like solar and wind power. They maintain grid stability and interoperability with existing systems by regulating voltage and preventing voltage variations brought on by intermittent power generation.
- c. **Data Centers:** To safeguard vital IT equipment from voltage disturbances, data centers use TCVLs. They guarantee continuous operation and data integrity by protecting servers, storage systems, and networking equipment against voltage sags, swells, or transients.
- d. **Commercial Buildings:** TCVLs are used in commercial buildings to safeguard delicate electronics from voltage fluctuations, including HVAC systems, elevators, and lighting controls. They aid in the dependable and effective functioning of building systems.
- e. **Improving Power Quality:** TCVLs can enhance power quality by lowering voltage fluctuations and upholding constant voltage levels. By reducing voltage sags brought on by power system flaws, they improve the quality of power delivered to attached loads.
- f.

**TCVLs provide the following advantages:**

- a. **Equipment Protection:** By shielding delicate equipment from voltage disturbances, TCVLs reduce damage and downtime. They minimize maintenance expenses and equipment replacement by ensuring the dependable operation of crucial systems.
- b. **Improved Power Quality:** By controlling voltage levels, TCVLs help to improve power quality. By reducing interruptions to connected loads and mitigating voltage changes, they improve the efficiency of power distribution as a whole.
- c. **Enhanced System Reliability:** By offering voltage stability and safety, TCVLs improve system dependability. Particularly in sensitive applications, they reduce the effects of voltage disruptions on machinery and aid in maintaining continuous operation.
- d. **Cost Savings:** By avoiding equipment breakdowns and downtime, TCVLs can reduce costs. TCVLs' protection lessens the need for pricy replacements, repairs, and production losses.
- e. **Adaptability and Flexibility:** TCVLs are adaptable due to their changeable voltage limits and modular construction. They enable flexibility and simple integration into existing power systems since they may be adjusted to particular system requirements.

For voltage management and protection in electrical power systems, the Thyristor Controlled Voltage Limiter (TCVL) is an important power electronic component. The safe and dependable operation of delicate equipment is guaranteed by TCVLs thanks to their capacity to reduce voltage disturbances and manage voltage levels. They are used in a variety of fields, such as industrial systems, the incorporation of renewable energy sources, data centers, commercial buildings, and the enhancement of power quality. Equipment protection, improved power quality, higher system dependability, cost savings, and flexibility are a few advantages of TCVLs. TCVLs are essential for preserving a consistent, high-quality power supply as power systems continue to change and encounter voltage issues.

**CONCLUSION**

In order to maximize the efficiency of electrical machinery, interphase power regulation is essential. One can increase machine productivity, boost power quality, and have better control over machine operation by adjusting the power distribution among the phases. The several interphase power control methods, including as voltage control, current control, and power factor control, have been discussed in this study along with their benefits and drawbacks. The application of these methods in various kinds of electrical machines has been covered, emphasizing the unique considerations and advantages. Interphase power control, however, is a complex field with continuing study and development, so it's crucial to keep that in mind. The distribution of power optimally under fluctuating load conditions, the reduction of losses, and dependable operation are still issues that need to be resolved. To improve interphase power regulation in electrical machines, future study should concentrate on improving already used methods, investigating fresh control approaches, and utilizing cutting-edge technologies. Interphase power control can continue to develop and aid in the development of effective and sustainable electrical machine systems by solving these issues and adopting new technology.

**REFERENCES:**

- [1] K. Ni *et al.*, "Electrical and Electronic Technologies in More-Electric Aircraft: A

- Review,” *IEEE Access*, 2019, doi: 10.1109/ACCESS.2019.2921622.
- [2] T. N. Lamichhane, L. Sethuraman, A. Dalagan, H. Wang, J. Keller, and M. P. Paranthaman, “Additive manufacturing of soft magnets for electrical machines a review,” *Materials Today Physics*. 2020. doi: 10.1016/j.mtphys.2020.100255.
- [3] S. R. Salkuti, “A survey of big data and machine learning,” *Int. J. Electr. Comput. Eng.*, 2020, doi: 10.11591/ijece.v10i1.pp575-580.
- [4] B. K. Bose, “Modern Power Electronics and AC Drives,” *Prentice-Hall*. 2002.
- [5] S. Eriksson, “Permanent magnet synchronous machines,” *Energies*. 2019. doi: 10.3390/en12142830.
- [6] X. Zhou, O. Abdelkhalik, and W. Weaver, “Power take-off and energy storage system static modeling and sizing for direct drive wave energy converter to support ocean sensing applications,” *J. Mar. Sci. Eng.*, 2020, doi: 10.3390/JMSE8070513.
- [7] I. Boldea, “Electric generators and motors: An overview,” *CES Trans. Electr. Mach. Syst.*, 2020, doi: 10.23919/tems.2017.7911104.
- [8] J. E. Q. Calvache, J. A. R. Zambrano, J. M. R. Scarpetta, and M. L. O. Gutierrez, “Test-Rig for Engineering Education Applied to the Control of Synchronous Generators,” *Rev. Iberoam. Tecnol. del Aprendiz.*, 2021, doi: 10.1109/RITA.2021.3137375.
- [9] Z. Zhu, S. Wang, B. Shao, L. Yan, P. Xu, and Y. Ren, “Advances in dual-three-phase permanent magnet synchronous machines and control techniques,” *Energies*. 2021. doi: 10.3390/en14227508.
- [10] M. Dybkowski, “Industrial Drive Systems. Current State and Development Trends,” *Ind. Drive Syst. Curr. State Dev. Trends*, 2016.

## TRANSIENT STABILITY OF ELECTRICAL MACHINES

**Mrs. Ragasudha Chundampunathil\***

\*Assistant Professor,  
Department of Electrical And Electronics Engineering,  
Presidency University, Bangalore, INDIA  
Email Id-ragasudha@presidencyuniversity.in

---

### ABSTRACT:

*Electrical machines must operate with transient stability to ensure their dependability and safety during transient events like faults, disruptions, or abrupt changes in operating circumstances. Electrical machines must have transient stability in order to operate reliably and safely during transient events. This chapter provides an overview of the mathematical models and methods that are used to evaluate and improve transient stability in electrical equipment. The goal is to give a thorough grasp of the variables affecting transient stability and the techniques used to keep electrical equipment stable.*

**KEYWORDS:** *Multimachine Power System, Potential Energy Function, Stability Analysis, Transient Stability, Two Machine System.*

---

### INTRODUCTION

These occurrences could be malfunctions, disruptions, or abrupt modifications to the working environment. Maintaining the functionality and longevity of electrical machinery requires an understanding of and analysis of transient stability. The ability of an electrical machine to continue operating steadily following a disruption or fault is referred to as transient stability. The machine experiences quick variations in voltage, current, and torque when a transient event like an electrical fault occurs. If these modifications are not adequately addressed, the machine may depart from its steady-state operating point, which could result in instability or even catastrophic failure. Mathematical models and analysis techniques are used to evaluate transient stability. These models depict electrical machines' dynamic behavior during transient events. They document the interactions between the machine's power system and its electrical, mechanical, and electromechanical components. Engineers can examine how the system responds to various transient circumstances and spot potential stability issues by simulating these models. The synchronous machine model is one popular model for transient stability investigation. The electrical machine is represented by this model as a synchronous generator interconnected to an electrical network.

It takes into account the network equations, the mechanical equations, and the electrical equations of the machine. The model can forecast the machine's behavior during transients such voltage deviations and oscillations of the rotor angle by simultaneously solving these equations. Fault analysis is a crucial component of transient stability analysis. Electrical system flaws can result in serious disturbances that compromise the stability of electrical machines. Studying a machine's behavior before, during, and after a defect occurs is known as fault analysis. Different fault types, such as open circuits or short circuits, are taken into account, and their effects on the stability of the machine are assessed. Circuit breakers are one example of a



protective device that is made to quickly identify and fix errors, reducing the damage they cause to the equipment. There are several different strategies that can be used to improve transient stability. Utilizing control systems and protective relays is one strategy[1]–[3].

Control systems continuously check the machine's working conditions and alter parameters like excitation, voltage regulation, or mechanical damping in response to deviations. When abnormal conditions, such as overcurrent or overvoltage, are detected, protective relays adjust the situation to stop instability. Transient stability is greatly influenced by effective system design and planning in addition to control techniques. Transformers and transmission lines, for example, can be properly sized and placed to increase the system's capacity to endure transient events and recover from them. The coordination of defense mechanisms and the use of appropriate grounding procedures also support system stability in general. Transient stability is a key characteristic of electrical machines that guarantees their dependable operation in transitory situations.

Engineers are able to evaluate and improve the transient stability of electrical equipment through the use of mathematical models and analysis tools. For stability to be maintained, fault analysis, control systems, and the best system design are crucial factors. The design and functionality of electrical machines will advance through ongoing transient stability research and development, making them more durable and effective in practical applications. The use of controllers to reduce power oscillations in transmission lines brought on by low frequency rotor swings in generators was discussed in the preceding chapter. The goal is to increase the power systems' small signal stability, which refers to their capacity to sustain synchronism in the face of minor disruptions that are constantly present (as a result of small changes in system load). Maintaining tiny signal stability is crucial for all typical operating scenarios that a power system face. In this chapter, we'll talk about how FACTS controllers can increase the transient stability of power systems. The stability of power systems during a severe or significant disturbance, such as a line fault followed by its clearing, is what is meant by transient stability. Along with the starting operating point, the location and type of the disturbance also affect transient stability. Loss of synchronism brought on by instability separates generators that are safeguarded by out-of-phase relays. It is implied by large rotor angle excursions that linear system theory cannot be used.

Numerical techniques are utilized to simulate the system and predict system stability because nonlinear system analysis is typically not practical. However, in the last 30 years, rapid, reasonably accurate, and able to handle the presence of FACTS and HVDC controllers while maintaining the network topology of the system, transient energy function approaches have been created. In this chapter, we'll examine control methods that can reduce oscillations until their magnitude falls below a certain threshold while simultaneously enhancing first swing stability. The bang-bang type of control action is initiated upon the detection of a disturbance and is terminated when the system gets closer to the stable equilibrium point following the disturbance. In contrast to the continuous controller employed for power oscillation damping, the transient stability controller is thus a "discrete" controller. The control action that is discrete in this context is one that is not ongoing. Here, it is assumed that enhancing transient stability is not a function of the damping controller. This is a reasonable assumption given that the damping controller's output is constrained to prevent interference with the power scheduling controller. As well the control method needed for dampening oscillations is very different from that for enhancing transient stability.

**Transient Stability of Two Machine System:** Power system analysis must consider transient stability since it is essential to the safe and dependable operation of electrical networks. Two synchronous generators that are connected to a common bus or linked together via a transmission line constitute a two-machine system in this sense. In order to analyze transient stability in a two-machine system, generators' dynamic behavior during disturbances is examined, and their ability to sustain synchronism is determined. The responsiveness of generators to significant disturbances like faults, abrupt load fluctuations, or the loss of a generator or transmission line is what is meant by a power system's transient stability. The generators' rotor angles, speeds, and electrical outputs alter significantly during such occasions. Transient stability analysis' major goal is to determine whether the system can retain stability and prevent significant changes in rotor angles, which can cause synchronism to be lost and even result in a system-wide blackout. There are a number of things to take into account while analyzing the transient stability of a two-machine system. These consist of the fault characteristics, system parameters, control schemes, and generator model. To depict how generators behave dynamically under transitory conditions, generator models like the classical model or more sophisticated models like the Park's model are utilized. These models take into account the machines' mechanical and electrical dynamics, including the rotor's inertia, damping, and electrical properties.

The transient stability of the system is influenced by system features such load characteristics, line impedances, and generator ratings. Low system inertia or flimsy interconnections can jeopardize stability, while large rotor inertia and high system damping typically improve it. The generator outputs are regulated and the stability of the system is maintained through control schemes including governor control and excitation control. The location, kind, and clearing time of the fault are only a few fault parameters that can significantly affect transient stability. In a two-machine system, a disturbance causes the generators' electrical power outputs to fluctuate, which alters the rotors' speeds and angles. Electromechanical torques generated by these variances operate on the rotor and tend to accelerate or decelerate the machines. In order to perform the transient stability analysis, a set of differential equations describing the dynamic response of the generators must be solved. In order to solve these equations and calculate the temporal evolution of rotor angles and speeds, numerical techniques like the Runge-Kutta method or the Euler method are frequently utilized. The crucial factor, known as the delta angle, is the difference in rotor angles between the two machines for evaluating transient stability. The crucial clearing angle is a point at which the delta angle loses stability and the generators may experience a significant swing or perhaps desynchronize. The equal-area criteria or simulation studies are frequently used to establish the critical clearing angle, which is dependent on system factors.

Different analysis techniques can be used to judge the transient stability of a two-machine system. The dynamic behavior of the system is simulated over time after a disruption in one popular method called time-domain simulation. Stability boundaries and potential stability problems can be found by examining the time-domain response. Eigenvalue analysis is a different method that entails linearizing the system equations and examining the eigenvalues of the linearized model. The system's stability and the mode of oscillations are shown by the eigenvalues. To sum up, the dependable operation of power systems depends on transient stability analysis of a two-machine system. System operators can take the necessary precautions to avoid widespread blackouts by analyzing the dynamic behavior of generators during

disturbances and evaluating their capacity to preserve synchronism. The analysis must take into account elements like generator model, system parameters, control schemes, and fault characteristics. The evaluation of transient stability and the identification of the critical clearance angle involve a variety of methods, such as time-domain simulation and eigenvalue analysis. Overall, transient stability analysis aids in the safe and reliable design and operation of power systems.

## DISCUSSION

**Extension to Multimachine Power Systems:** Multimachine power systems, which are more like real-world power networks, can be included in transient stability analysis in addition to two-machine systems. Multiple synchronous generators are connected by transmission lines to form multimachine power systems, which are more complicated in terms of dynamic behavior and stability analysis. Each generator in a multimachine power system has its own dynamics and communicates with the others via the electrical network. When analyzing the transient stability of multimachine systems, all generators' dynamic responses to disturbances are examined, and their capacity to uphold synchronism and system stability is evaluated. The analysis of the transient stability of multimachine power systems involves various additional factors. These cover control plans, system parameters, fault characteristics, and the depiction of generator models and transmission line models. In comparison to two-machine systems, generator models employed in multimachine systems are often more intricate and advanced. The intricate electrical and mechanical dynamics of generators are captured by sophisticated models like the Park's model and the intricate IEEE excitation system models.

These models provide a more accurate description of generator behavior during transients by taking into account variables like field current control, generator excitation limitations, and saturation effects. To accurately represent the interaction between generators in multimachine systems, transmission line modeling is crucial. Transmission line models take into account the length and impedance of the line as well as line properties like resistance, inductance, and capacitance. The electrical properties of transmission lines can be accurately modeled using a variety of models, such as the pi model or the Bergeron model[4], [5]. In multimachine systems, stability is crucially maintained by control techniques. To manage generator outputs and uphold system stability, governor control and excitation control are used. By altering excitation and governor set points based on system conditions, coordinated control systems, such as automated voltage regulators (AVRs) and power system stabilizers (PSSs), are frequently employed to increase transient stability. The transient stability of multimachine systems is affected by system variables such as generator ratings, line impedances, load characteristics, and connector strengths. For the system to remain stable during disturbances, it is essential that certain system parameters, such as adequate damping and sufficient rotor inertia, are met. Additionally, the position and strength of connections between generators affect the stability and dynamic interactions of the system. Multimachine systems' transient stability can be significantly impacted by fault characteristics such as fault location, type, and clearing time.

Large-scale disturbances brought on by faults can alter the synchronization and dynamic behavior of generators. In order to evaluate the system's capacity for recovery and stabilization following faults, fault characteristics must be taken into account in transient stability analysis. Similar to those employed in two-machine systems, analysis methodologies for

transient stability assessment in multimachine systems are extended to take into account interactions between several generators. Time-domain simulation, which simulates the system's dynamic behavior over a period of time after shocks, is still a popular technique. The simulation accurately depicts the interactions between the generators and offers information about stability limits and potential problems. By linearizing the system equations and examining the linearized model's eigenvalues, eigenvalue analysis can also be used to study multimachine systems. The stability of the system is evaluated and crucial oscillation modes are identified with the aid of eigenvalue analysis. Other methods, including modal analysis and Lyapunov-based methods, can be used for transient stability analysis in multimachine systems in addition to time-domain simulation and eigenvalue analysis. Additional information about system dynamics, mode geometries, and stability margins is provided by these techniques. by taking into account the interactions between many generators, transient stability analysis can be expanded to multimachine power systems. When evaluating the stability of multimachine systems, advanced generator models, transmission line modeling, control schemes, system parameters, and fault characteristics are critical factors to consider. System operators can guarantee the safe and dependable functioning of intricate power networks by undertaking thorough transient stability analyses.

**Derivation of Potential Energy Function:** Determining the relevant variables and creating an expression to describe the system's stored energy are necessary steps in the process of constructing a potential energy function for a dynamic system. A potential energy function is frequently used in the context of transient stability analysis to examine the stability of power systems. Here, we'll lay down a generic procedure for determining a multimachine power system's potential energy function.

**Determine the System Variables:** To begin, we must determine the pertinent variables that best represent the dynamic behaviour of the system. These factors commonly include the rotor angles, rotor speeds, and electrical state variables of each generator in a multimachine power system.

**Define Mechanical Energy:** A generator's mechanical energy is linked to its rotating motion. The formula for the rotor's kinetic energy is  $K = 0.5J\omega^2$ , where K is the kinetic energy, J is the rotor's moment of inertia, and  $\omega$  is the rotor speed. The potential energy associated with the mechanical position of the rotor can be defined as:

$$P_m = 0.5 H \delta^2$$

Where  $P_m$  is the mechanical potential energy, H is the stiffness coefficient (sometimes referred to as inertia constant), and  $\delta$  is the rotor angle.

**Consider Electrical Energy:** The electrical state variables, such as the voltage magnitude and phase angle, are connected to the electrical energy stored in a generator.

$$P_e = 0.5 * C * V^2,$$

Where  $P_e$  is the electrical potential energy, C is the capacitance parameter, and V is the voltage magnitude, is an expression for the potential energy related to the electrical state.

**Calculate the overall Potential Energy:** The mechanical and electrical potential energies are added to determine the overall potential energy of the system. As a result, the potential energy function for a multimachine power system can be expressed as follows:  $P = (0.5 H_i \delta_i^2) + (0.5$

$C_i V_i^2$ ), where  $P$  is the total potential energy,  $H_i$  and  $\delta_i$  stand for the stiffness and rotor angle of the  $i$ -th generator, respectively, and  $C_i$  and  $V_i$  for capacitance and voltage magnitude.

**System-Specific Considerations:** Depending on the system features and modelling presumptions, the specific shape of the potential energy function may change. To take into consideration system-specific characteristics, new phrases or modifications might occasionally be used.

**Analysis and Stability Assessment:** After the potential energy function has been generated, transient stability of the system can be evaluated using stability analysis techniques. To identify stability margins and crucial spots, this may entail examining the potential energy function's characteristics, such as its minimum or maximum points.

It's crucial to remember that the potential energy function is a simplified illustration of the dynamics of the system and might not fully encompass the nuances of the behavior of the power system. However, it offers a helpful framework for transient stability analysis and works well as a tool for control design and stability assessment.

**Potential Energy Function of SVC, SSSC, UPFC:** We give a brief explanation of each device and the accompanying potential energy function to explain the potential energy functions for the Static Var Compensator (SVC), Static Synchronous Series Compensator (SSSC), and Unified Power Flow Controller (UPFC).

**Static Var Compensator (SVC):** A Static Var Compensator (SVC) is a reactive power compensation device based on power electronics used in power systems. It is made up of a capacitor bank and a voltage source converter (VSC) coupled in parallel. The dynamics of the VSC and the energy contained in the capacitor bank can be used to estimate the potential energy function for an SVC.

$I$  represent the current flowing through the VSC, while  $V_c$  represents the voltage across the capacitor bank. The following is an explanation of the SVC's potential energy function:

$$U_{SVC} = 0.5 C V_c^2$$

Where  $C$  is the capacitor bank's capacitance. The energy held in the capacitor bank, which is proportional to the square of the voltage across it, is represented by this potential energy function.

**Static Synchronous Series Compensator (SSSC):** In power systems, SSSCs are power electronics-based devices that are used to regulate the transmission line parameters. A voltage source converter (VSC) coupled in series with the transmission line makes up this system. By taking into account the dynamics of the VSC and the energy stored in the series inductor, it is possible to estimate the potential energy function for an SSSC.

$I$  represent the current flowing through the VSC, while  $V_s$  represents the voltage across the series inductance. The following is a definition of the SSSC's potential energy function:

$$U_{SSSC} = 0.5 L I_s^2$$

Where  $L$  is the series inductor's inductance. The energy held in the series inductor, which is proportional to the square of the current passing through it, is represented by this potential energy function.



**Unified Power Flow Controller (UPFC):** A power electronics-based device known as a UPFC is used to regulate the flow of both active and reactive power in power systems. It combines into a single device the features of an SVC and an SSSC. By taking into account the dynamics of the VSCs, the energy held in the capacitor bank, and the series inductor, it is possible to construct the potential energy function for a UPFC.  $V_c$  stands for the voltage across the capacitor bank,  $V_s$  for the voltage across the series inductor, and  $I_c$  and  $I_s$ , respectively, stand for the currents flowing through the VSCs. According to this definition, the UPFC's potential energy function is:

$$U_{UPFC} = 0.5 C V_c^2 + 0.5 L I_s^2$$

The sum of the energy held in the capacitor bank and the series inductor is represented by this potential energy function. The energy held in the capacitor bank and the series inductor may be used to determine the potential energy functions for SVC, SSSC, and UPFC, respectively. These hypothetical energy functions shed light on these devices' energy dynamics and energy storage capacities, which are crucial for their control and performance in power systems.

**Control Strategy for a Two Machine System:** Implementing a variety of methods and algorithms to effectively manage and coordinate the functioning of the machines is part of a control plan for a two-machine system. The main objectives are to maximize productivity, reduce downtime, and optimize system performance. This control technique often includes a number of elements, including coordination, monitoring, fault detection and diagnosis, and decision-making. I'll describe a control plan for a system with two machines in this response. Establishing a thorough monitoring system is the first stage in creating a control strategy for a two-machine system. This system uses sensors that are mounted on the machines to continuously monitor their operational parameters and collect real-time data. To evaluate the condition and effectiveness of the machinery, parameters including temperature, pressure, vibration, and power consumption can be evaluated.

Any variations from typical operating circumstances can be quickly identified by closely monitoring these data, allowing for prompt intervention to avert potential breakdowns or failures. For the two-machine system to be controlled effectively, a fault detection and diagnosis module must be implemented in addition to monitoring. To find any anomalies or machine issues, this module evaluates the data that has been gathered. The control system can precisely identify errors and identify their main causes by using methods like statistical analysis, machine learning, or rule-based algorithms. Early fault discovery enables quick maintenance or repairs, minimizing the effect on system performance and decreasing downtime. In order to operate the two machines in the system as efficiently as possible, coordination is essential. To promote effective resource usage and prevent conflicts, this entails coordinating the operations of the two machines. Algorithms for task scheduling and distribution across the machines should be included in the control strategy based on variables like workload, machine capabilities, and priorities.

Coordination that is effective can increase system throughput, decrease idle time, and boost overall productivity. A two-machine system's control technique includes decision-making in its entirety. It entails choosing the best course of action depending on the goals that need to be achieved and the system's current state. In order to choose the best course of action, decision-making algorithms might take into account variables including machine availability, maintenance needs, energy consumption, and production goals. For instance, the control system may decide to shift the workload to the other unit if one machine needs maintenance in order to

maintain operation. Communication and feedback loops are essential for the proper implementation of the control plan. The machines should be able to communicate with one another through the control system, exchanging information, sharing data, and coordinating operations. Through the use of feedback loops, the control system can modify its plans in response to actual performance and results[6]–[8].

The control strategy can be constantly updated over time by tracking how the system responds to control operations, which will increase system performance and dependability. Integrating the control approach with a user interface that gives operators access to real-time information and control capabilities is also essential. The user interface should show pertinent system characteristics, alarms, and diagnostic data so that users can decide what to do and how to do it. Additionally, it should give operators the ability to change control parameters, reverse certain operations, or start maintenance procedures as needed. Monitoring, fault detection and diagnosis, coordination, decision-making, communication, and feedback loops are all components of a control plan for a two-machine system. The control system can enhance production, reduce downtime, and optimize machine performance by combining various components. Based on the system's performance input, the control approach should be adaptable, flexible, and continually enhanced. The two-machine system can work effectively and dependably, reaching production goals and guaranteeing smooth operations, with an appropriate control strategy in place.

**Extension of the Control Strategy to Multimachine Power Systems:** Addressing the particular difficulties and complexities brought on by the interconnected operation of numerous machines is necessary to adapt the control strategy to multimachine power systems. The aim of a power system is to preserve system stability, optimize power flow, and successfully manage contingencies while ensuring a steady and reliable supply of electrical energy. I'll describe an application of the control method to several machine power systems in this response. Maintaining system stability is one of the most important components of regulating a multimachine power system. This calls for controlling the frequency, voltage, and power flow within reasonable bounds. The control approach should employ methods like voltage control and automated generation control (AGC) in order to accomplish this. In order to ensure that generation and consumption are in balance, AGC modifies the power output of generators in response to changes in load demand.

Excitation control and reactive power control are two voltage control methods that keep the proper voltage levels at various points throughout the system. In multimachine power systems, contingency management is also essential. A contingency might be a problem, a line failure, or a sudden shift in demand. Advanced protection strategies and quick fault detection algorithms should be incorporated into the control strategy to quickly locate and isolate defects and reduce their negative effects on system stability. Remedial action plans (RAPs), which specify the proper control steps to be implemented in reaction to eventualities like load shedding or generator tripping in order to restore system stability, should also be included in the strategy. The control method for multimachine power systems heavily relies on coordination and optimization. Algorithms for power flow regulation ensure effective use of transmission lines and reduce losses. These algorithms establish the ideal power flow in the system by taking into account variables including generation capabilities, load requirements, and transmission constraints.

Algorithms for economic dispatch assist in maximizing the distribution of generation assets to reduce the overall cost of power output while meeting demand. Wide-area monitoring and control systems (WAMCS) can be incorporated into multimachine power systems to increase the efficacy of the control strategy. In order to give synchronized measurements of voltage, current, and frequency, WAMCS makes use of phasor measuring units (PMUs) positioned at various points throughout the system. Real-time monitoring of system dynamics is made possible by these measurements, enabling more precise control and quicker reaction to disruptions. Additionally, WAMCS enable information sharing across control centres, enabling coordinated control operations over a large geographic area. When expanding the control strategy to multimachine power systems, cybersecurity is another crucial factor to take into account. Protecting against cyber threats is crucial since the electricity infrastructure is becoming more digital and communicative.

Strong cybersecurity measures, such as secure communication protocols, intrusion detection systems, and access controls should be incorporated into the control strategy to protect the system from unwanted access, data tampering, or disruption of control functions. System stability, contingency management, coordination, optimization, wide-area monitoring and control, and cybersecurity are all issues that need to be taken into consideration when applying the control strategy to multimachine power systems. The control strategy can guarantee the dependable and effective operation of the power system by integrating these components. The control approach needs to be flexible and able to respond to a wide range of operational circumstances and contingencies. Multimachine power systems may provide dependable electricity supply, support the integration of renewable energy sources, and satisfy the changing requirements of contemporary power grids when an efficient control approach is in place[9], [10].

**Studies of Discrete Control for Stability Improvement:**The development of control mechanisms that make use of discrete actions or interventions to increase the stability of dynamic systems is the main goal of studies on discrete control for stability improvement. The objective is to build discrete control algorithms that stabilize the system or enhance its stability features because these systems may display instability or have undesired dynamic behavior. I'll give a summary of the research on discrete control for increased stability in my reply. Designing switching control techniques is one area of study in discrete control for improving stability. Changing control entails choosing various control rules or parameters according to the system's operational circumstances or the occurrence of particular events. These occurrences may involve setpoint adjustments, disturbances, or the identification of particular system states.

The system's stability can be raised by varying the control laws or parameters. To increase stability, researchers have looked into a number of switching control techniques, including state-dependent switching, time-triggered switching, and event-triggered switching. The creation of supervisory control strategies is another field of study. Incorporating a discrete control layer that monitors and directs the operation of lower-level continuous control loops is known as supervisory control. To achieve stability goals, the discrete control layer works with the continuous control loops and makes decisions based on inputs at the system level. Techniques like hybrid systems, Petri nets, and finite-state machines can be used to create supervisory control schemes. These techniques give the control architecture the capacity to incorporate discrete decisions, enhancing stability. Additionally, studies have concentrated on the use of

model predictive control (MPC) to increase stability. A predictive model of the system is used by MPC, a control approach, to optimize control actions over the long term. To increase stability, discrete control actions, such as turning on or off actuators or altering control setpoints, can be incorporated into the MPC formulation.

The control algorithm can proactively take discrete steps to prevent instability or lessen its impacts because to the predictive character of MPC, which enables the consideration of future system behavior. Researchers have also looked into the usage of event-triggered control techniques to increase stability. Instead of continuously updating the control signals, event-triggered control updates the control actions only when certain events or conditions occur. Control updates can be initiated depending on event occurrences, which lowers control effort and boosts stability. The goal of event-triggered control techniques is to optimize resource use while balancing control performance with communication or computational resources. Studies have also looked into using hybrid control systems to increase stability. To achieve stability goals, hybrid control blends discrete and continuous control operations. Based on system states or events, these systems alternate between various control modes or control rules. Discrete control actions can change control parameters, activate or deactivate control loops, or switch between alternative control techniques.

In order to improve stability in dynamic systems with nonlinear or complicated dynamics, hybrid control methods offer flexibility and adaptability. Diverse methodologies, including as switching control, supervisory control, model predictive control, event-triggered control, and hybrid control, are included in the study of discrete control for stability improvement. This research seek to develop discrete action or intervention-based control mechanisms to improve the stability of dynamic systems. Stability can be increased, unwanted behavior can be reduced, and system performance can be maximized by introducing discrete control into the control architecture. These studies aid in the creation of sophisticated control strategies for a variety of applications, including industrial processes, power systems, and robots.

## CONCLUSION

When designing and running electrical equipment, transient stability is a crucial factor to take into account. It is possible to assess and improve transient stability by using the right methodologies and mathematical model analysis. Engineers can create plans to increase the resilience of electrical devices by studying the variables that affect stability during transient occurrences like faults and disturbances. Additionally, sustaining steady machine performance during transients can be achieved by optimizing operating conditions and putting control systems in place. The design and performance of electrical machines will advance thanks to ongoing research and development in the area of transient stability, assuring their dependable and effective functioning in a variety of real-world applications.

## REFERENCES:

- [1] B. E. B. Bidouche, T. Lubin, and S. Mezani, "Transient performance of a magnetically geared induction machine," *COMPEL - Int. J. Comput. Math. Electr. Electron. Eng.*, 2020, doi: 10.1108/COMPEL-12-2019-0485.
- [2] F. Selwa, L. Djamel, and L. Imen, "The transient stability study of a synchronous generator based on the rotor angle stability," *Int. J. Electr. Comput. Eng.*, 2015, doi:

- 10.11591/ijece.v5i6.pp1319-1327.
- [3] M. Aurangzeb, A. Xin, S. Iqbal, and M. U. Jan, "An Evaluation of Flux-Coupling Type SFCL Placement in Hybrid Grid System Based on Power Quality Risk Index," *IEEE Access*, 2020, doi: 10.1109/ACCESS.2020.2996583.
- [4] A. Zaw Latt, "Transient Stability Analysis of 3-Machine, 7-Bus System Using ETAP," *Int. J. Sci.*, 2019, doi: 10.18483/ijsci.2105.
- [5] O. Mo, S. Darco, and J. A. Suul, "Evaluation of Virtual Synchronous Machines with Dynamic or Quasi-Stationary Machine Models," *IEEE Trans. Ind. Electron.*, 2017, doi: 10.1109/TIE.2016.2638810.
- [6] A. Mitra and D. Chatterjee, "Active power control of dfig-based wind farm for improvement of transient stability of power systems," *IEEE Trans. Power Syst.*, 2016, doi: 10.1109/TPWRS.2015.2397974.
- [7] L. Bigarelli, M. Di Benedetto, A. Lidozzi, L. Solero, and P. J. Grbovi, "FPGA-Based Permanent Magnet Synchronous Machine Emulator with SiC Power Amplifier," *IEEE Trans. Ind. Appl.*, 2021, doi: 10.1109/TIA.2021.3104272.
- [8] S. Kadiman, O. Yuliani, and T. Handayani, "Teaching power system stabilizer and proportional-integral-derivative impacts on transient condition in synchronous generator," *Bull. Electr. Eng. Informatics*, 2021, doi: 10.11591/eei.v10i5.3087.
- [9] M. O. Benaissa, S. Hadjeri, and S. A. Zidi, "Impact of PSS and SVC on the power system transient stability," *Adv. Sci. Technol. Eng. Syst.*, 2017, doi: 10.25046/aj020372.
- [10] Z. Chen, X. Xiao, C. Li, Y. Zhang, and Q. Hu, "Real-time transient stability status prediction using cost-sensitive extreme learning machine," *Neural Comput. Appl.*, 2016, doi: 10.1007/s00521-015-1909-9.



*Editorial Board*

**Dr. B.S. Rai,**  
Editor in Chief  
M.A English, Ph.D.  
Former Principal  
G.N. Khalsa PG.College,  
Yamunanagar, Haryana, INDIA  
Email: balbirsinghrai@yahoo.ca

**Dr. Romesh Chand**  
Professor- cum-Principal  
CDL College Of Education,Jagadhri,  
Haryana, INDIA  
Email: cdlcoe2004@gmail.com

**Dr. R. K.Sharma**  
Professor (Rtd.)  
Public Administration,  
P U Chandigarh, India  
Email: sharma.14400@gmail.com

**Dr. Mohinder Singh**  
Former Professor & Chairman.  
Department of Public Administration  
K. U. Kurukshetra (Haryana)  
Email: msingh\_kuk@yahoo.co.in

**Dr. S.S. Rehal**  
Professor & chairman,  
Department of English,  
K.U. Kurukshetra (Haryana)  
Email: srehal63@gmail.com

**Dr. Victor Sohmen**  
Professor,  
Deptt. of Management and Leadership  
Drexel University Philadelphia,  
Pennsylvania, USA.  
Email: vsohmen@gmail.com

**Dr. Anisul M. Islam**  
Professor  
Department of Economics  
University of Houston-Downtown,  
Davies College of Business  
Shea Street Building Suite B-489  
One Main Street, Houston,  
TX 77002, USA  
Email: islama@uhd.edu

**Dr. Zhanna V.Chevychalova, Kharkiv,**  
Associate Professor,  
Department of International Law,  
Yaroslav Mudry National Law University,  
UKRAINE  
Email:zhannachevychalova@gmail.com

**Dr. Kapil Khanal**  
Associate Professor of Management,  
Shankar Dev Campus,  
Ram Shah Path T.U. Kirtipur, NEPAL.  
Email:kapilkhanal848@gmail.com

**Dr. Dalbir Singh**  
Associate Professor  
Haryana School of Business, G.J.U.S & T, Hisar,  
Haryana, INDIA  
Email: dalbirhsb@gmail.com

**Nadeera Jayathunga**  
Senior Lecturer  
Department of Social Sciences,  
Sabaragamuwa University, Belihuloya,  
SRI LANKA  
Email: nadeesara@yahoo.com

**Dr. Parupalli Srinivas Rao**  
Lecturer in English,  
English Language Centre,  
King Faisal University, Al-Hasa,  
KINGDOM of SAUDI ARABIA  
Email: vasupsr@yahoo.com

## Categories

- Business Management
- Social Science & Humanities
- Education
- Information Technology
- Scientific Fields

## Review Process

Each research paper/article submitted to the journal is subject to the following reviewing process:

1. Each research paper/article will be initially evaluated by the editor to check the quality of the research article for the journal. The editor may make use of iThenticate/Viper software to examine the originality of research articles received.
2. The articles passed through screening at this level will be forwarded to two referees for blind peer review.
3. At this stage, two referees will carefully review the research article, each of whom will make a recommendation to publish the article in its present form/modify/reject.
4. The review process may take one/two months.
5. In case of acceptance of the article, journal reserves the right of making amendments in the final draft of the research paper to suit the journal's standard and requirement.

## Published by

### South Asian Academic Research Journals

A Publication of CDL College of Education, Jagadhri (Haryana)  
(Affiliated to Kurukshetra University, Kurukshetra, India)

Our other publications :

South Asian Journal of Marketing & Management Research (SAJMMR)

ISSN (online) : 2249-877X

SAARJ Journal on Banking & Insurance Research (SJBIR)

ISSN (online) : 2319 – 1422