

DOI: **10.5958/2249-7137.2021.01949.2**

COTTON STALK REMOVER

Maxammadjon Xabibullayevich Mamadaliyev*; **Mirkomil Mirzatolibovich Halilov****;
Muxammadjon Abdumomin ogli Rozimatov***;
Xushnubek Nurmuxammad ogli Raxmonov***

*Associate Professor,
 Andijan institute of agriculture and agro technology,
 UZBEKISTAN

**Associate Professor,
 Andijan institute of Mechanical Engineering,
 UZBEKISTAN

***Assistant,
 Andijan institute of Mechanical Engineering,
 UZBEKISTAN

Email id: ruzimatov1991@inbox.ru

ABSTRACT

It is known that on farms, winter wheat is planted between the rows of harvested cotton fields before the cotton stalks are removed, so that the fields are cultivated until the seedlings are fully germinated. techniques are not included. This is because they cause great damage to the germination and development of young seedlings and reduce yields. The cotton stalks left in the fields are harvested after the ground is completely frozen. However, as a result of their roots remaining in the soil, they develop fusarium wilt and spread to other areas. Therefore, it is important to develop a machine to completely uproot the cotton stalks in the wheat fields[1].

KEYWORDS: *Tractor, Generator, Cotton Stalks, Cotton Picking Machine, Disc Mechanism*

INTRODUCTION

The only requirement for the use of such agricultural technology is to preserve the emerged young shoots of wheat from mechanical damage that occurs during the subsequent uprooting of cotton stalks and their harvesting.

Therefore, the innovators and technical workers of the Republic are faced with the task of developing and introducing in cotton-growing farms a simple and reliable technical means for mechanical harvesting of cotton stalks, while preserving mature wheat crops[2].

Materials

The objective of the proposed development is to create a mechanized device for removing cotton stalks that is simple in design and reliable in operation, while it must meet the following requirements:

- The action of the stem suppression mechanism should be based on the method of cutting, not uprooting;
- Provide a mechanism for transporting cut stems with the formation of a bunch;
- the machine must ensure the processing of the aisle from both sides;
- to preserve as much as possible and not to damage the grown beds of wheat.

Since the problem of the proposed device is solved as follows.

In a device for removing stalks of cotton, containing a frame mounted on support wheels with a stalk cutting mechanism located on it, a pulling-transporting working body and a beam shaper, the stalk cutting mechanism is made in the form of a fast-revolving disk knife installed in the nose of the frame at an angle in the direction of travel of the device, the pulling-transporting working body is located on the frame two pairs of cone-shaped rollers rotating towards each other with a profiled surface, while one end of the roller is mounted on a sliding bearing, and the other is fixed on a worm wheel coupled with a worm, cinematically interconnected with the axis of the support wheels, and the beam former is made in the form of a hollow drum with versatile winding of blades[3].

The proposed device for removing stalks of cotton (Fig. 1) contains a spatial welded frame 1, consisting of longitudinal beams 2, reinforced with transverse crossbars 3, vertical struts 4 and scarves 5. The frame rests on two rear 6 and one front 7 wheels. In the front part of the frame, a curved U-shaped bracket 8 with a pulling hook 9 is welded to the longitudinal beams 2 for aggregated with a tractor (not shown in the figure) and a swivel sub frame 11 is located on the hinge hinges 10, on which a quickly revolving mechanism 12 is located on both sides with a circular knife 13, fixed with a cap gull 14. The cutting mechanism is fixed to the dressing room by means of bandage connectors 15, and feeding is carried out through a flexible electrically insulated cable 16 connected to a DC generator from a tractor (not shown in the figure). On the frame at a distance of 6, equal to the width of the row spacing of cotton, there are two pairs of pulling-transporting working bodies, each of which includes cones of the bearing rollers 17 with a profiled surface rotating towards each other, while the lower end of the roller is installed on the field by a reducer 19, which contains a common worm shaft with a left turnover 20 and right turnover 21 worm and mating, respectively, with a left turnover 22 and right turnover 23 worm wheel. A kinematic sprocket 24 is fixed on the worm shaft, interconnected through a chain transmission 25 with a double sprocket 26 mounted on the axle 27 of the rear wheels 6. From the side of the worm gear 19 on the frame 1 in a vertical plane above the rear wheels, a beam former 28 is installed, made in the form of a hollow drum with versatile winding of blades 29, the

rotation of which is carried out by means of a double sprocket 25, a chain transmission 30 and a driven sprocket 31. On the unloading side, a slide 32 is installed on the frame.

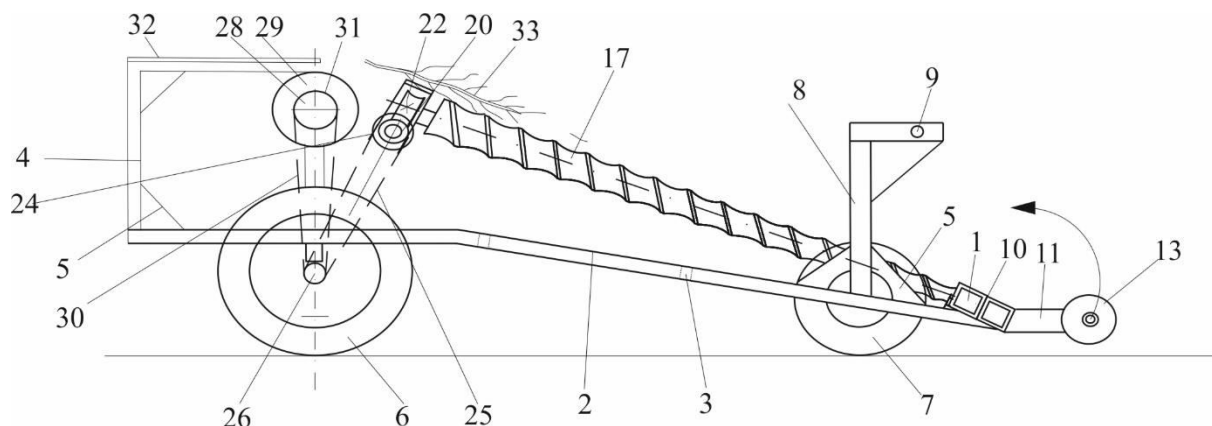

Figure 1. Structural diagram of a device for removing stalks of cotton.

The device for removing stalks of cotton works as follows.

Before starting work, the swivel subframe 11 is installed in a vertical position and two fast revolving cutting mechanisms 12 are mounted on it in a mirror image, they are checked at idle, under connecting to a DC or AC generator generated by the tractor. Then the disc knives 13 are installed and secured with the union nut 14 and the check is carried out again. After making sure that the electrical part is working, the precursor is lowered into the working position and, through the traction hook 9, is aggregated with the MTZ-80 tractor[4].

Results

When passing along a row spacing of $h = 90$ cm and bypassed young shoots of wheat on the slopes of the beds, circular knives 13, set at an angle to the cotton stalk, cut over the root part of the stem 33 without damaging the wheat growth. The cut off stems come between the cone-shaped rollers 17 rotating towards each other, which pull the stems and simultaneously transport them in the direction of the beam former 28. In this case, cotton stalks from dried roller pairs, in the form of compacted bundles, enter the former 28 and in the process of rotation of the latter are combined into a larger bundle (sheaf) and removed through the middle of the slide 32. Here it can be tied with twine and stored as fuel.

The developed kinematic diagram of the device ensures the operation of all cone-shaped rollers and the beam former due to the rotation of the support wheels 6.

The use of a quickly revolving disc mechanism for cutting cotton stalks at the level of the soil surface does not damage the germinated wheat cover, which was typical for mechanical uprooting. This method of removing stems is especially important when surface freezing of the soil, in which uprooting is impossible.

The serial production of the bottom device will allow preserving the winter sowing of wheat and will provide the local population with cheap biological fuel and is an economic help for the population.

However, we can also cite the following information. The fields are cleared of cotton stalks by hand. On some farms, this process is done by using cotton stalks to grind them and scatter them on the field. This leaves stems 15-20 cm above the field surface. As a result, the disease mentioned above can spread to and damage wheatgrass[5].

It should be noted that the complete removal of cotton stalks from the fields with their roots will ensure a certain level of fuel demand of the population. Using such a machine reduces the cost of removing the stalks by 30% and the use of manual labor by 90%. [6].

A design scheme has been developed for a machine that can completely uproot cotton stalks in wheat fields. During the operation of this machine, both sides of the cotton stalks are cut at a distance of 4-5 cm with disc knives, and the cotton stalks are pulled out using a drum equipped with special clamps. As a result, the roots of wheat seedlings are pulled out of the cotton stalks without transplanting. This saves resources and increases productivity.

CONCLUSION

Based on the above, based on the analysis of the literature and research, a design scheme was developed for a machine that can completely uproot cotton stalks in wheat fields (see Figure 2). During the operation of this machine, the two sides of the cotton stalks are cut with disc knives at a distance of 4-5 cm, and the cotton stalks are pulled out using a drum equipped with special clamps. As a result, the roots of wheat seedlings are pulled out of the cotton stalks without transplanting. This saves resources and increases productivity.



Figure 2. A model of a cotton picking machine.

The proposed machine is aggregated with 1-2 class tractors and is called by us as a resource-saving machine used for clearing wheat fields from cotton stalks, and based on the above, this work is aimed at developing and justifying its parameters. .

REFERENCES

1. M.Shoumarova, T.Abdullaev Agricultural machines. - Tashkent. The Teacher, 2002.
2. Kpenin N.I., Sakun V.A. Agricultural and reclamation machines. Moscow, Agropromizdat, 1980.
3. Listopad G.E. et al. Agricultural and reclamation machines. Moscow, Gosizdat, 1986.

4. Karpenko A.N., Khalansky V.M. Agricultural machines Moscow, "Kolos", 1983.
5. M.A.Rzimatov. IMPROVEMENT OF OIL FILTER ELEMENTS. Universum Technical Sciences No. 2(83), Part 1, February 25, 2021 <https://7universum.com/ru/tech/archive/item/11321>
6. M.A.Ro'zimatov. ENSURING RELIABLE OPERATION OF THE COMPRESSION RING. Universum Technical Sciences No. 3(84), March 25, 2021 <https://7universum.com/ru/tech/archive/item/11384>
7. M.A.Ro'zimatov. IMPROVING ECOLOGY AND ENVIRONMENTAL PROTECTION (ON THE EXAMPLE OF THE REPUBLIC OF UZBEKISTAN). Universum Technical Sciences No. 5(86), May 25, 2021 <https://7universum.com/ru/tech/archive/item/11702>