

ACADEMICIA

ISSN (online) : 2249-7137

# ACADEMICIA

An International  
Multidisciplinary Research  
Journal

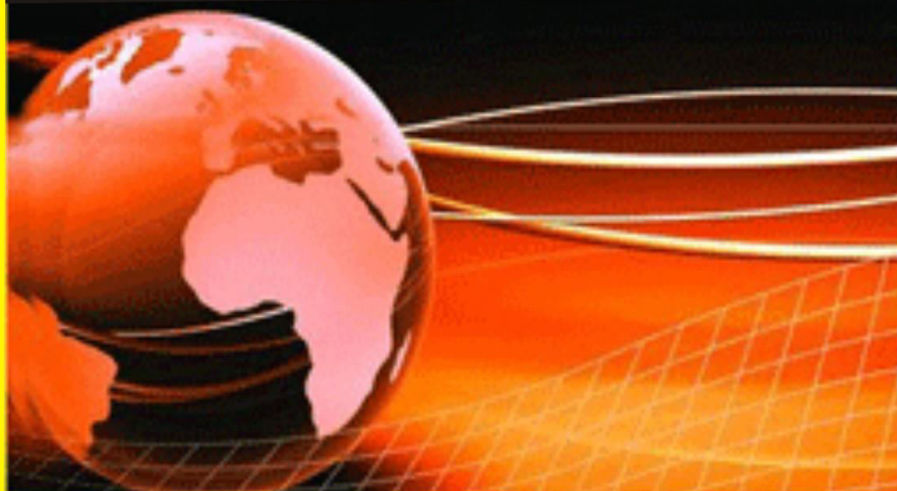

Published by  
**South Asian Academic Research Journals**  
A Publication of CDL College of Education, Jagadhri  
(Affiliated to Kurukshetra University, Kurukshetra, India)

**ACADEMICIA**

An International Multidisciplinary Research Journal

ISSN (online) : 2249 –7137

Editor-in-Chief : Dr. B.S. Rai

Impact Factor : SJIF 2021 = 7.492

Frequency : Monthly

Country : India

Language : English

Start Year : 2011

Indexed/ Abstracted : Scientific Journal Impact Factor (SJIF2020 - 7.13), Google Scholar, CNKI Scholar, EBSCO Discovery, Summon (ProQuest), Primo and Primo Central, I2OR, ESJI, IJIF, DRJI, Indian Science and ISRA-JIF and Global Impact Factor 2019 - 0.682

E-mail id: saarjournal@gmail.com

**VISION**

The vision of the journals is to provide an academic platform to scholars all over the world to publish their novel, original, empirical and high quality research work. It propose to encourage research relating to latest trends and practices in international business, finance, banking, service marketing, human resource management, corporate governance, social responsibility and emerging paradigms in allied areas of management including social sciences , education and information & technology. It intends to reach the researcher's with plethora of knowledge to generate a pool of research content and propose problem solving models to address the current and emerging issues at the national and international level. Further, it aims to share and disseminate the empirical research findings with academia, industry, policy makers, and consultants with an approach to incorporate the research recommendations for the benefit of one and all.



# ACADEMICIA

## An International Multidisciplinary Research Journal

(Double Blind Refereed & Peer Reviewed International Journal)



SR. NO.	PARTICULAR	PAGE NO.	DOI NUMBER
1.	A STUDY ON USER DEEDS TOWARDS PATANJALI PRODUCTS IN COIMBATORE CITY Dr. P. Rajjini, Mrs A. Arthi	1-8	10.5958/2249-7137.2021.01859.0
2.	PARADIGMATIC TYPOLOGY OF LEXICO-SEMANTIC VARIANTS OF THE WORD Dzhumanova D.R	9-13	10.5958/2249-7137.2021.01860.7
3.	IMPROVING THE METHODS OF TEACHING FOREIGN LANGUAGES IN PRIMARY SCHOOL Guli Orinboyeva Murodbekqizi, Malika Raxmatullayeva Azimjonqizi, Kamolova Umida Salomatqizi	14-17	10.5958/2249-7137.2021.01861.9
4.	LINGUISTIC INTERPRETATION OF THE EPITHET IN FRENCH Vazirakhon Mirzaeva	18-22	10.5958/2249-7137.2021.01862.0
5.	FEATURES OF THE ETHNOCULTURAL MODEL OF FAMILY RELATIONS IN FAMILIES Amirkhojayev Shukurjon Kurbonovich	23-28	10.5958/2249-7137.2021.01863.2
6.	EFFECTIVE METHOD FOR PHOTOGRAPHIC RECORDING OF HEAT FIELDS OF OBJECTS AND LASER RADIATIONS BASED ON A GAS DISCHARGE CELL Sharifa Bekmuradovna Utamuradova, Khojakbar Sultanovich Daliev, Zokir Khaydarov, Dilmurod Abdujabbor ugli Rakhmanov	29-33	10.5958/2249-7137.2021.01864.4
7.	STUDY OF EPIZOOTOLOGY OF TRIXOPHYTIS DISEASE IN COWS OF SAMARKAND REGION Shopulatova Zumrat Jahongirovna, Usmonova Khadicha Juraevna	34-37	10.5958/2249-7137.2021.01865.6
8.	SPIRITUAL AND MORAL CRITERIA OF STUDENT EDUCATION Abdullayeva Gulchekxra Abdullajonovna	38-42	10.5958/2249-7137.2021.01866.8
9.	ANALYSIS AND ASSESSMENT OF ANTHROPOMETRIC BODY MASS INDEX FOR WOMEN OF FERTILIZED AGE IN BUKHARA REGION Yakhyoyeva H.Sh, Rizaeva M.A	43-46	10.5958/2249-7137.2021.01867.X

10.	<b>PREVALENCE OF LIPID AND GLYCEMIC COMPONENTS OF METABOLIC SYNDROME IN THE POPULATION OF ELDERLY AND OLD AGE IN BUKHARA</b> Gulchekhra Khamraevna Razhabova, Karomat Shoyimovich Dzhumaev	47-50	10.5958/2249-7137.2021.01868.1
11.	<b>IDENTIFY THE FEATURES OF COMMERCIAL VOCABULARY IN THE CATEGORY OF ADJECTIVES AND TEACH THEM USING MODERN TECHNOLOGY</b> Toshpulatov Dilshodjon Abdurafiqovich	51-57	10.5958/2249-7137.2021.01869.3
12.	<b>ON THE SEMANTICS OF SOME WINGED WORDS IN THE FRENCH LANGUAGE</b> Isakova Guzalkhon Nematovna	58-61	10.5958/2249-7137.2021.01870.X
13.	<b>TURKIC CLASSIC POETRY: TRANSLATION PROBLEMS</b> O. Dadaboyev	62-67	10.5958/2249-7137.2021.01871.1
14.	<b>PECULIARITIES OF MORPHOMETRIC CHARACTERISTICS OF PHYSICAL DEVELOPMENT OF ELDERLY AND OLD AGE PERSONS (REVIEW)</b> Shukhrat Zhumaevich Teshaev, Karomat Shoyimovich Dzhumaev, Gulchekhra Khamraevna Razhabova	68-72	10.5958/2249-7137.2021.01872.3
15.	<b>THICKNESS OF EPICARDIAL ADIPOSE TISSUE AS A PREDICTOR OF CARDIOVASCULAR RISK</b> Orziqulova Sh. A	73-78	10.5958/2249-7137.2021.01873.5
16.	<b>THE INVESTIGATION OF ALL POSSIBLE STRUCTURES OF PHRASEOLOGICAL UNITS WITH PROPER NAMES</b> Rakhimova Nigora Sobirjonovna	79-86	10.5958/2249-7137.2021.01874.7
17.	<b>INTERPRETATION OF PHONETIC EVENTS IN UZBEK AND TURKISH LANGUAGES</b> Mirzayeva Gozal Qobuljonovna	87-93	10.5958/2249-7137.2021.01875.9
18.	<b>HEURISTIC AND MEMORY IN ROBOT – HUMAN INTERACTION IN THE NOVEL VIRTUAL GIRL BY AMY THOMPSON</b> Dr. Balamayuranathan B, Anjana A	94-100	10.5958/2249-7137.2021.01876.0
19.	<b>CREATIVE IDEA, AGE AND SYMBOLISM</b> Shukurova Sabohat Odilovna	101-108	10.5958/2249-7137.2021.01877.2
20.	<b>THE ROLE OF THE FAMILY IN RAISING CHILDREN</b> Karimova Gavhar Kudratilla qizi	109-112	10.5958/2249-7137.2021.01878.4
21.	<b>CHOOSING THE BEST OPTION</b> Saipnazarov Shaylozbek Aktamovich, Khodjabaeva Dilbar	113-120	10.5958/2249-7137.2021.01879.6
22.	<b>PSYCHOLOGICAL AND PEDAGOGICAL PROBLEMS OF AN INCOMPLETE FAMILY</b> Shaumarova Zilola Abdushukurovna	121-126	10.5958/2249-7137.2021.01880.2
23.	<b>PROBLEMS OF LEXICOGRAPHIC INTERPRETATION OF PHRASEOLOGICAL POLYSEMIS OF UZBEK LANGUAGE</b> Rakhimova S.J	127-132	10.5958/2249-7137.2021.01881.4



24.	<b>STRUCTURAL CHANGES IN HIGHER EDUCATION IN THE PROCESS OF FORMATION OF THE THIRD RENESSANCE FOUNDATION</b> Khakimov Akbar Anvarovich	133-137	10.5958/2249-7137.2021.01882.6
25.	<b>FEATURES OF THE COURSE OF ARTERIAL HYPERTENSION ASSOCIATED WITH METABOLIC SYNDROME</b> Axmedova Gulmira Ixtiyarovna, Juraeva Khafiza Iskandarovna	138-146	10.5958/2249-7137.2021.01883.8
26.	<b>NATIONAL AND EDUCATIONAL SIGNIFICANCE OF THE JADID CORPS</b> Ubaydullayeva Gulruh Gayratovna	147-151	10.5958/2249-7137.2021.01884.X
27.	<b>PRESCHOOL EDUCATION REFORM</b> Shamuratova Khurliman Kutlimuratovna	152-155	10.5958/2249-7137.2021.01885.1
28.	<b>METHODS FOR REDUCING SEISMIC FORCES ACTING ON BUILDINGS AND STRUCTURES</b> Egamberdiyev B.O	156-162	10.5958/2249-7137.2021.01914.5
29.	<b>EXPLORING THE TECHNOLOGICAL POSSIBILITIES OF NEXT-GENERATION FLAT KNITTING MACHINES</b> Elyor Kholboyev, Dilafruz Khamidova, Maftunaxon Abdurakhimova, Nilufar Khankhadjaeva	163-170	10.5958/2249-7137.2021.01887.5
30.	<b>THE IMPORTANCE OF USING ADVANCED PEDAGOGICAL TECHNOLOGIES IN TEACHING CHEMISTRY</b> Ganieva Gaukhar Bazarbaevna	171-174	10.5958/2249-7137.2021.01888.7
31.	<b>MANIPULATIVE RELATIONSHIP OF A DESTRUCTIVE PERSON IN THE FAMILY</b> Sharafutdinova Khadichaxon Gulyamutdinovna	175-179	10.5958/2249-7137.2021.01889.9
32.	<b>EYES AND OTHER FACE MEMBERS IN NAVOI GAZELLES</b> Norkulova Shahnoza Tolqinovna	180-189	10.5958/2249-7137.2021.01890.5
33.	<b>RATIONAL USE OF DIFFERENT TYPES OF FEEDINGS IN THE FEEDING OF KARAKOL SHEEP</b> D.M.Parmanova	190-193	10.5958/2249-7137.2021.01891.7
34.	<b>PRIMARY VAGINAL MALIGNANT MELANOMA: A RARE ENTITY</b> Rathee. N, Pandey.A, Dimri. K, Gupta. N, Suraj, Kaur. A, Rathee. H, Singh. B	194-198	10.5958/2249-7137.2021.01893.0
35.	<b>USE OF "YOU" AND "YOU" (POLITE FORM) PARABLE IN COMMUNICATION BEHAVIOR BETWEEN UZBEK AND GERMAN FAMILIES</b> K.Kakharov	199-203	10.5958/2249-7137.2021.01892.9
36.	<b>EXISTENCE AND ITS COMPONENTS "A NEW APPROACH"</b> Abdukhalikov Safar	204-212	10.5958/2249-7137.2021.01895.4
37.	<b>TYPOLOGY OF EXERCISES AND EXPERIMENTAL TRAINING ON TEACHING METHODOLOGICAL FEATURES OF THE RUSSIAN LANGUAGE</b> Khamraeva Gulshod Arslanovna	213-216	10.5958/2249-7137.2021.01896.6

38.	<b>COMPONENTS OF GENDER IDENTIFICATION AND DIFFERENTIATION</b> Zuhrahon Seitova, Bahram Utemyratov	217-224	10.5958/2249-7137.2021.01897.8
39.	<b>MODERN TRANSFORMATION OF THE ESSENCE OF THE COMPETITIVENESS OF INDUSTRIAL ENTERPRISES</b> Tashmuxamedova Karima Samatovna	225-229	10.5958/2249-7137.2021.01898.X
40.	<b>MEANS OF GOVERNMENT REGULATION OF INVESTMENT AND CONSTRUCTION ACTIVITIES</b> Axmedova Sanobar Ikrom qizi	230-234	10.5958/2249-7137.2021.01899.1
41.	<b>PROBLEMS ARISING IN THE ORGANIZATION OF FINANCIAL MANAGEMENT OF HOUSING STOCK MANAGEMENT COMPANIES AND THEIR SCIENCE-BASED SOLUTIONS</b> Berdiyeva Dilfuza Axatovna	235-240	10.5958/2249-7137.2021.01900.5
42.	<b>STRATEGY FOR INCREASING THE INNOVATIVE POTENTIAL OF ENTERPRISES OF THE CONSTRUCTION MATERIALS INDUSTRY IN THE CONDITIONS OF INNOVATIVE ECONOMY”</b> Xaydarova Ezoza Shukrullayevna	241-245	10.5958/2249-7137.2021.01901.7
43.	<b>CRAFTSMANSHIP THROUGH MUGS OF PRIMARY SCHOOL STUDENTS TARGETED REFERRAL TECHNOLOGIES</b> Muxamadaliyeva Madinabonu Bohodirjon qizi	246-249	10.5958/2249-7137.2021.01902.9
44.	<b>PRODUCTION AND STORAGE TECHNOLOGY APPLE CHIPS</b> Karimova Dilnoza Zafarjanovna, Akramov Umidilla Ikramdjanovich	250-254	10.5958/2249-7137.2021.01903.0
45.	<b>THE ROOTS OF SOME ALGEBRAIC EQUATIONS ONE WAY TO DETERMINE</b> Abdusalom Hakimov, Baxiyor Hayitovich Ungarov, Maftuna Abdinazarova	255-259	10.5958/2249-7137.2021.01904.2
46.	<b>CALORIC DELINEATION OF BOTH GASOLINE AND DIESEL BLENDS USING DSC</b> Dr. K. Prahlada Rao, Kothagundu Subrahmanyam	260-270	10.5958/2249-7137.2021.01894.2
47.	<b>THE THEME AND IDEA OF THE NOVEL “SHAYTANAT”</b> Turdiyeva Yulduz Zayniddinqizi	271-274	10.5958/2249-7137.2021.01905.4
48.	<b>THE PROFESSIONAL PEDAGOGICAL ACTIVITY IN MODERN EDUCATION</b> Tursumatova Shaxlo Samievna, Raxmonova Malohat Mirkomilovna, Khomidov Vohidjon Obidovich	275-277	10.5958/2249-7137.2021.01906.6
49.	<b>METHODOLOGICAL FEATURES OF "HISTORICAL PROPERTY AJAM"</b> Qodirjon Ergashev	278-283	10.5958/2249-7137.2021.01907.8
50.	<b>DEVELOPMENT OF CREATIVE ABILITY OF FUTURE TEACHERS ON THE BASIS OF ACMELOGICAL APPROACH</b> Muminova Gulnozaxon Sultan qizi	284-286	10.5958/2249-7137.2021.01908.X

51.	<b>THE CAUSES OF FORBIDDEN RELIGIOUS EXTREMIST GROUPS</b> Sobirov Utkir Tursunboy Ogli	287-290	10.5958/2249-7137.2021.01909.1
52.	<b>THE EMERGENCE OF THE SCIENCE OF HADITH IN THE EAST</b> Bobokhodjayev Sadulla Abdullayevich	291-294	10.5958/2249-7137.2021.01910.8
53.	<b>TALMEH (SIGN) IN THE EPIC “KUTADGU BILIG”</b> Barno Abdurahmonova	295-298	10.5958/2249-7137.2021.01911.X
54.	<b>THE DEVELOPMENT OF INTERCULTURAL AND LINGUO CULTURAL COMPETENCE IN HIGHER EDUCATION</b> Hilola Muinovna Karoeva	299-303	10.5958/2249-7137.2021.01919.4
55.	<b>THE USE OF AN IMPROVED EXPERIMENT IN TEACHING CHEMISTRY IN THE PROCESS OF CONTINUING EDUCATION</b> Akhmadjon Mirzaevich Jumanov, Nargiza Elmirzaqizi Sobirova, Gulibonu Xusniddinqizi Yusupalieva	304-308	10.5958/2249-7137.2021.01913.3
56.	<b>ECOLOGICAL ISSUES IN SH. SEITOV'S POETRY</b> Konakbay Turdybaev	309-316	10.5958/2249-7137.2021.01915.7
57.	<b>ANALYSIS OF THE PRACTICE OF TRANSPARENCY IN BUDGET POLICY IN UZBEKISTAN</b> Gulmira Muzaffar kizi Samandarova	317-327	10.5958/2249-7137.2021.01916.9
58.	<b>INFLUENCE OF CULTIVAR COMBINATIONS AND SEEDLING THICKNESS ON THE FORMATION OF PHYTOMETRIC INDICATORS AND PRODUCTIVITY OF PEAR TREES IN INTENSIVE ORCHARDS</b> Yunusov R, Nazarova S.M, Ganieva F.A, Ataeva Z.A	328-331	10.5958/2249-7137.2021.01917.0
59.	<b>THE ROLE OF THE LANGUAGE IN RAISING THE LEVEL OF HUMANITARIAN TRAINING OF SPECIALISTS FROM TECHNICAL UNIVERSITIES</b> Nargis Kudratkhodjaeva, Nigora Giyasova, Nigora Yusupova	332-336	10.5958/2249-7137.2021.01918.2
60.	<b>THE IMPERATIVES FOR VOCATIONAL AND ENTREPRENEURIAL EDUCATION: THE NYSC PERSPECTIVE</b> Brig. Gen. Shuaibu Ibrahim	337-348	10.5958/2249-7137.2021.01920.0
61.	<b>THE USE OF ANTHROPONYMS AND PSEUDONYMS IN ALISHER NAVOI'S GAZELLES</b> Gulruh Sohibblek qizi, Nargizaxon Rustamovna Umarova	349-353	10.5958/2249-7137.2021.01921.2
62.	<b>INNOVATIVE APPROACHES TO TEACHING HISTORICAL SCIENCE</b> Yuldash Haydarov	354-358	10.5958/2249-7137.2021.01922.4
63.	<b>ASSESSMENT OF THE METHODS OF THE STATE OF HYPERGLYCEMIA AT DIFFERENT BODY MASSES</b> Nurilloeva Shakhodat Nurillo kizi	359-366	10.5958/2249-7137.2021.01923.6

64.	<b>IGNITED ROCKS - ENERGY-SAVING RAW MATERIALS FOR PRODUCTION OF PORTLANDCEMENT CLINKER</b> Mironyuk Nina Anatoleynovna, Maxsudova Nozimaxon Djaparxanovna, Atabayev Farrux Baxtiyorovich, Abdullayeva Nigoram Maxmudovna	367-371	10.5958/2249-7137.2021.01924.8
65.	<b>TEACHING TO WORK ON THE TEXT IN THE MASTERING OF THE CONTENT OF THE STORY “THE YOUTH OF ALISHER” (GRADE 4)</b> Kurbonov Zayniddin, Kilichboyeva Khurshida	372-378	10.5958/2249-7137.2021.01925.X
66.	<b>USING RELIEF NOUNS IN THE ENGLISH DICTIONARIES</b> Farmonov Bekzod Begmatovich	379-383	10.5958/2249-7137.2021.01926.1
67.	<b>CAUSES, EARLY DIAGNOSIS AND FEATURES OF LATENT ENDOMETRITIS IN COWS</b> B.M.Eshburiev	384-388	10.5958/2249-7137.2021.01927.3
68.	<b>CATEGORY OF INFORMATIVITY IN VISUAL POETIC TEXTS</b> Yunusova Hilola Ravshan kizi	389-393	10.5958/2249-7137.2021.01928.5
69.	<b>INTERNATIONAL COOPERATION OF THE REPUBLIC OF UZBEKISTAN IN THE CONTEXT OF REGIONAL ENVIRONMENTAL PROTECTION</b> Ismoil Nurmetov	394-399	10.5958/2249-7137.2021.01929.7
70.	<b>PRINCIPLES OF ORGANIZING THE SPIRITUAL – ENLIGHTENMENT ACTIVITIES OF FUTURE TEACHERS</b> Rakhimov Asomiddin Anorboevich	400-407	10.5958/2249-7137.2021.01930.3
71.	<b>ATHLETES' PERFORMANCE WITH YOGA AND ASSOCIATED EXERCISES</b> Dr. Anjana Lohan	408-414	10.5958/2249-7137.2021.01931.5
72.	<b>IN THE NETWORK OF ROADS APPLICATION OF THE INTELLIGENT TRANSPORT SYSTEM</b> Ashurov Elyor Tulkinovich, Sharipov Bokhodir Kholboevich	415-418	10.5958/2249-7137.2021.01932.7
73.	<b>STRUCTURAL TYPES OF UZBEK LANGUAGE HEMERONYMS</b> Sapayeva Boljon Kadamovna	419-422	10.5958/2249-7137.2021.01933.9
74.	<b>TOURISM POTENTIAL OF UZBEKISTAN AND WAYS OF ITS EFFECTIVE USE, DEVELOPMENT OF DIGITAL TOURISM, WORLD EXPERIENCE IN TOURISM DEVELOPMENT</b> Kholikulov Ravshanbek, Musurmanov Islombek	423-430	10.5958/2249-7137.2021.01934.0
75.	<b>MATHEMATICAL MODELING IN HYDROGEOLOGICAL RESEARCH</b> Sh.S.Akhralov, J.J.Jumanov	431-439	10.5958/2249-7137.2021.01935.2
76.	<b>SEMANTICS OF THE LEXEME “GREEN”</b> Israilova Saodat Turapovna	440-448	10.5958/2249-7137.2021.01936.4



77.	<b>INTERPRETATION OF THE LIVESTOCK TRADITIONS AND CEREMONIES IN ARCHAEOLOGICAL RESEARCHES (ON THE EXAMPLE OF JIZZAKH OASIS)</b> Eshmukhamatov Akhror Sharipovich	449-458	10.5958/2249-7137.2021.01937.6
78.	<b>ON SOME WAYS TO PREPARE STUDENTS FOR PROFESSIONAL ACTIVITY IN TECHNICAL HIGHER EDUCATION INSTITUTIONS</b> Adizova Sevara Yusupovna	459-462	10.5958/2249-7137.2021.01938.8
79.	<b>RECOMMENDATION AND FOR THE IMPLEMENTATION OF INNOVATION IN CONSTRUCTION</b> Djabriev Akbarali Normurodovich, Karimov Inomjon Ortikbaevich	463-468	10.5958/2249-7137.2021.01939.X
80.	<b>STANDARDIZATION OF SUBSTANCE BASED ON GINKGO BILOBA</b> Hulkar Tuygunovna Zairova, Farhod Khakimovich Tukhtaev, Nozima Saidova Sadikova	469-475	10.5958/2249-7137.2021.01940.6
81.	<b>SCIENTIFIC STYLE OF NAVOI LANGUAGE</b> Berdak Yusuf	476-483	10.5958/2249-7137.2021.01941.8
82.	<b>OMAR TERMIZI'S BOOK OF KITAB UN-NIYYA</b> Mukhiddin Choriyev	484-487	10.5958/2249-7137.2021.01942.X
83.	<b>ULTRASOUND EXAMINATION IN THE PREVENTION OF COMPLICATIONS OF OPERATIONS ON THE BILIARY TRACT</b> Akhmedov F.Kh, Khamdamova M. T	488-491	10.5958/2249-7137.2021.01943.1
84.	<b>MORPHOMETRIC FEATURES OF ANTHROPOMETRIC PARAMETERS OF ADOLESCENTS LIVING IN THE CITY OF BUKHARA ENGAGED IN ATHLETICS</b> Hikmatova M. F, Khamdamova M.T	492-495	10.5958/2249-7137.2021.01944.3
85.	<b>ELEVATION OF PHYSICAL AND MENTAL STRENGTH WITH SPORTS PERFORMANCE WITH TRADITIONAL EXERCISES AND YOGA</b> Dr. Anjana Lohan	496-502	10.5958/2249-7137.2021.01945.5
86.	<b>TEACHING ECONOMICS AND THE EVOLUTION OF MODERN ECONOMIC EDUCATION IN HIGHER EDUCATION INSTITUTIONS</b> Nargiza. A. Inagamova	503-506	10.5958/2249-7137.2021.01946.7
87.	<b>TAX RISKS ANALYSIS AND THEIR ROLE IN THE ECONOMY OF COUNTRY</b> Muqaddas. R. Elbayeva	507-510	10.5958/2249-7137.2021.01947.9
88.	<b>THE NEED TO STUDY AVIATION TERMINOLOGY IN UZBEK LANGUAGE</b> Rano Turaevna Ergashova	511-514	10.5958/2249-7137.2021.01948.0

89.	<b>COTTON STALK REMOVER</b> Maxammadjon Xabibullayevich Mamadaliyev, Mirkomil Mirzatolibovich Halilov, Muxammadjon Abdumomin ogli Rozimatov, Xushnubek Nurmuxammad ogli Raxmonov	515-519	10.5958/2249-7137.2021.01949.2
90.	<b>A NEW APPROACH TO THE TREATMENT OF CHRONIC CONSTIPATION AND DIAGNOSED DYSBACTERIOSIS IN CHILDREN WITH DOLICHOSIGMA</b> Isroilov M.S	520-525	10.5958/2249-7137.2021.01950.9
91.	<b>ANALYSIS OF ACCELERATION SLIP REGULATION SYSTEM USED IN MODERN CARS</b> Makhammadjon Alijon ogli Qobulov, Akhror Abduqohhorovich Abdurakhimov	526-531	10.5958/2249-7137.2021.01951.0
92.	<b>HIGH-YIELDING VARIETIES AND LINES FOR BREEDING DURUM WHEAT</b> Khasan Xolbazarovich Karshiboev	532-537	10.5958/2249-7137.2021.01952.2
93.	<b>STUDYING THE LIFE AND WORK OF SHUKRULLO IN UZBEK-TURKISH LITERATURE (BASED ON RESEARCH BY NUMONJON RAKHIMJANOV AND SHUAYIB KARAKASH)</b> Marhabo Xudayberganovna Kuchkarova	538-541	10.5958/2249-7137.2021.01953.4
94.	<b>PROSPECTS FOR THE DEVELOPMENT OF DISTANCE EDUCATION (IN THE EXAMPLE OF KARSHI STATE UNIVERSITY)</b> Norkhol Guzarovna Eshkoraeva, Bahodir Haknazarovich Shovaliev, Jahongir Qobil ugli Odilov	542-545	10.5958/2249-7137.2021.01954.6
95.	<b>THE ROLE OF FOREIGN MIGRATION IN THE DEVELOPMENT OF NATIONAL DIASPORAS</b> Shahnoza Tillyabaeva	546-554	10.5958/2249-7137.2021.01955.8
96.	<b>THE RESULTS OF EXPERIMENTS THE WIDTH OF THE SOIL DEEPER LIKE GOUGEAND ITS IMPACT ON STUDYING PERFORMANCE</b> Tuxtakuziev A, Khasanov U.I, Ochilov M.Z	555-559	10.5958/2249-7137.2021.01956.X
97.	<b>MENTAL HEALTH PROBLEMS AMONG AIRCREW</b> Yeliseyev N.A	560-568	10.5958/2249-7137.2021.01957.1
98.	<b>ECONOMIC IMPACT OF KISAN CREDIT CARD SCHEME ON PROFITABILITY OF CROPS IN DEORIA DISTRICT OF UTTAR PRADESH</b> Hraday Kumar, Awadhesh Kumar, Vijay Kumar Pal, Satish Chandra Verma, Vinay Kumar Rawat	569-588	10.5958/2249-7137.2021.01958.3
99.	<b>OPTIMIZATION OF THE ACID ACTIVATION PROCESS OF BENTONITE</b> Jobir X. Xamroyev, Normurot I. Fayzullayev, Jasur H.Shukurov, Rustam D. Berdiyev	589-597	10.5958/2249-7137.2021.01959.5

100.	<b>CHARACTERISTICS OF THE <math>Fe_2(MOO_4)_3 \cdot MOO_3</math> CATALYST USED IN THE SYNTHESIS OF NANOCARBONS FROM METHANE</b> Hilola N. Xolmirzayeva	598-605	10.5958/2249-7137.2021.01960.1
101.	<b>PRODUCTIVITY OF GRAIN OF WHEAT OF SAND OF CENTRAL FERGANA</b> Zokirova S, Kholmatova Sh, Ergasheva N	606-609	10.5958/2249-7137.2021.01961.3
102.	<b>WALNUT SPECIES IN THE FERGANA VALLEY, THEIR BOTANICAL CHARACTERISTICS</b> Rajavaliyeva Z, Jamoliddinov R, Mamurova N	610-613	10.5958/2249-7137.2021.01962.5
103.	<b>AGROTECHNICS OF GRAPE GROWING ON STONE GRAVELY BLACK GRAY SOILS</b> Abdurahimova M, Imyaminova, Rajavaliyeva Z, Alijonova M	614-617	10.5958/2249-7137.2021.01963.7
104.	<b>THEORETICAL FOUNDATIONS OF THE ACCELERATION SLIP REGULATION SYSTEM</b> Abdulaziz Solijon ogli Khusanjonov, Shohruhbek Ilhomjon ogli Nosirjonov	618-623	10.5958/2249-7137.2021.01964.9
105.	<b>ETHNOGRAPHIC FOLKLORISTS IN THE NOVELS OF THE INDEPENDENCE PERIOD</b> Turayeva Iroda Shermatovna	624-626	10.5958/2249-7137.2021.01965.0
106.	<b>CONSIDERATION OF SPEECH ANALYSIS IN LINGUISTICS</b> Narzullayeva Diyora Zayniddin kizi	627-630	10.5958/2249-7137.2021.01966.2
107.	<b>EDUCATION OF YOUTH IN ISLAM</b> Bahauddinov Shamsuddin Salievich	631-634	10.5958/2249-7137.2021.01967.4
108.	<b>A TRADITION AND ARTISTIC-AESTHETIC RENEWAL - AS A FACTOR FOR THE DEVELOPMENT OF LITERATURE</b> Boltayeva Iqbol Tadjibayevna	635-640	10.5958/2249-7137.2021.01968.6
109.	<b>NEW PRODUCING WAY FOR KNITTED FABRIC WITH HIGH HEAT SHIELDING PROPERT</b> G.Kh. Gulyaeva, M.M. Mukimov	641-644	10.5958/2249-7137.2021.01969.8
110.	<b>ABOUT BURYNING SOIL IN FERGANA (EXAMPLE: THE HILL OF SARIQORGON IN UCHKO'PRIK DISTRICT).</b> Artiqova Gozalxon girls Nosirjon, Zakirova Sanoat Khomdomovna, Axmedova Dilfuzaxon	645-646	10.5958/2249-7137.2021.01970.4
111.	<b>TOKYO OLYMPICS AND PERFORMANCE OF INDIAN ATHLETES IN MULTIPLE SPORTS TOURNAMENTS</b> Dr. Anjana Lohan	647-653	10.5958/2249-7137.2021.01975.3
112.	<b>PRODUCTIVITY AND MORPHOGENETIC DESCRIPTION OF IRRIGATED SEMI-AUTOMORPH SOILS OF LIGHT SEROZEM SOIL ZONE</b> Bobomurodov Sh.M, Bobonorov B.B, Ismonov A.J, Tursunov Sh.T, Baxodirov Z.A	654-659	10.5958/2249-7137.2021.01971.6

113.	<b>COMPARISON OF THE TURBULENCE MODEL FOR SWIRLED FLOWS</b> Dilshod Qaxramonugli Khushvaktov	660-664	10.5958/2249-7137.2021.01972.8
114.	<b>PEDAGOGICAL ENVIRONMENT FACTOR IN THE DEVELOPMENT OF THE EDUCATION SYSTEM: PROBLEMS AND APPROACHES</b> Ravshan Yarashevich Ergashov	665-672	10.5958/2249-7137.2021.01973.X
115.	<b>THE STUDY OF KOMIL KHOREZMI'S LIFE AND LITERARY HERITAGE IN UZBEK LITERATURE</b> Shahobiddin Babayarovich Nuriddinov	673-679	10.5958/2249-7137.2021.01974.1
116.	<b>METHODS OF THERAPY AND PROPHYLAXIS OF PYROPLASMOSIS AND TAYLERIOSIS OF LARGE CATTLE</b> Duskulov Vohidjon Muhitdinovich, Nasimova Dildora Rayimjonova, Norkuziev Berdiyoz Bozorboy ogli, Narzullaev Abbas Akram ogli	680-686	10.5958/2249-7137.2021.01976.5
117.	<b>METHODS TO INCREASE THE PRODUCTIVITY OF IRRIGATED GRAZING SOILS</b> Musurmanova Mohinur Murot kizi	687-692	10.5958/2249-7137.2021.01977.7
118.	<b>PHYTONYMIC COMPARISON AS A MEANS TO CREATE IMAGE IN POETRY</b> Djalilova Zarnigor	693-698	10.5958/2249-7137.2021.01978.9
119.	<b>THE ROLE OF EXCURSIONS TO SPIRITUAL PLACES IN THE DEVELOPMENT OF THE SPIRITUALITY OF THE YOUNGER GENERATION</b> Utanov Utkir Kurbanovich	699-702	10.5958/2249-7137.2021.01979.0
120.	<b>TREATMENT METHODS FOR GENERALIZED CANDIDA-ASSOCIATED PERIODONTITIS (LITERATURE REVIEW)</b> Avezova Salomat Mahmudjonovna	703-706	10.5958/2249-7137.2021.01980.7
121.	<b>METHODOLOGICAL APPROACHES TO ANALYSIS AND ASSESSMENT OF IMPLEMENTATION ENERGY SAVING POTENTIAL OF REAL ESTATE PROPERTIES AT THE CITY LEVEL: FORM, TECHNOLOGY, RESOURCES</b> Akhrorova S.T, Pulatov Sh.A	707-715	10.5958/2249-7137.2021.01981.9



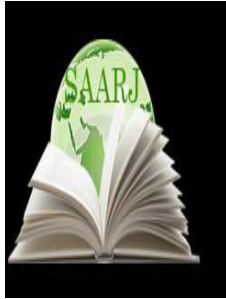

**ACADEMICIA**  
**An International**  
**Multidisciplinary**  
**Research Journal**  
 (Double Blind Refereed & Peer Reviewed Journal)

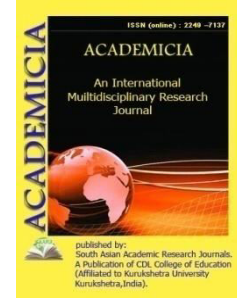

**DOI: 10.5958/2249-7137.2021.01859.0**

## A STUDY ON USER DEEDS TOWARDS PATANJALI PRODUCTS IN COIMBATORE CITY

**Dr. P. Rajini\*; Mrs A. Arthi\*\***

\*Associate Professor,  
 Head –Post Graduate & Research, Department Of Commerce,  
 Rathnavel Subramaniam College of Arts and Science (Autonomous),  
 Coimbatore, Tamil Nadu, INDIA

\*\*Research Scholar, Assistant Professor,  
 Department Of Commerce,  
 Rathnavel Subramaniam College Of Arts And Science (Autonomous),  
 Coimbatore, Tamil Nadu, INDIA

### ABSTRACT

*India, is one of the country on the planet, where Indian were more rely upon nature, regardless of whether it's food, cover, meds, from antiquated time, additionally in present time as well. In this manner India is biggest market of natural items whether it's clinical or food items. The primary point of this article to study that to examine Patanjali customer conduct under different scale for example ethnocentrism, loyalty, low value searchers, and so forth this paper separated into five sections, initial segment presentation which incorporates presentation of Patanjali product restricted, and buyer conduct. Second part audit of writing, in this segment we attempted to sum up different examination article on Patanjali items and its customers purchasing conduct. Third segment research technique, study plan five-point Likert scale and information gathered by the 100 visiting costumers on Patanjali stores, and enlightening measurements utilized for the examination. A fourth area discovery shows that the broad dispersion strategy, mental and character qualities assume a huge part while buyers select Patanjali items. Fifth area decision and suggestion, with a viable ramifications method of information assortment may be chaotic for respondents, there might be an opportunity of miss end because of little example size, and its creativity/esteem this exploration work was finished during my PhD program in 2020, around then, there were not many specialists did on Patanjali. So during that time, this exploration was new at wide scale.*

**KEYWORDS:** *End user behavior, Patanjali Products, end user buying behavior and Creativeness*

---

## 1. INTRODUCTION

The customer behavior is the investigation of how singular clients, gatherings or associations select, purchase, use, and discard thoughts, merchandise, and administrations to fulfill their requirements and needs. It alludes to the activities of the purchasers in the commercial center and the hidden thought processes in those activities. For the research work of patanjali products user deeds in the Coimbatore city.

## 2. History of Ayurveda goods

In olden period there is no foreign goods people were using the Ayurveda raw material which is given by the nature then they converted into finish goods later by middle period people prefer foreign goods there was many choice was there fragrance smell add in those product that made people to change the preference now in this modern period people are running beyond Ayurveda product. Customer has preferring patanjali products what made the customer to go beyond the Ayurveda product like patanjali product. After that researchers analyze data and on the basis of findings, research concludes the research study. The spot that is known for Aryans, called Aryavrat, covers an immense area including the Himalayas and is accepted to where the Rishis and Munis resided. The human progression of these Ayurveda and Ayurveda products is significantly influenced by the unique academic responsibility of these Rishis and Munis like Patanjali, Aryabhatt, etc. The helpful statutes of Patanjali are parceled into eight fragments or branches. These territories are – inward drug, Medical procedure, Natural arrangement, Pediatrics, Toxicology, Restoring fix, Spanish fly fixes, and profound retouching. These eight regions are classified as Patanjali". Patanjali is a whole or widely inclusive structure that fuses the mind, body, and soul. Several many years, the shows of Patanjali reduced as a result of the normal and human disturbances and moreover by the assault of far off culture into India. The hallowed test was either destroyed or taken. Nonetheless, there were various "Vaidyas" or experts in India who sorted out some way to secure a segment of the data open in the Blessed holy messages. Divine plants that keep up long life and extraordinary prosperity are presently being rediscovered. Many re-energized gatherings of Vaidyas who are addressed impressive expert in specific parts of Patanjali have started working again in India. Today there is a recuperation of the out of date culture and custom characteristic for Patanjali, which is the enrichment of the old human advancement to the high level world. Due to various debilitated effects found in the current arrangement system called the Allopathic, other than it has a high repairing rate. Thusly, everyone of the world advances toward the Patanjali game plan of treatment. Thusly the Patanjali ascends as the billions dollars industry in India. Display day Patanjali medications made by the countless associations in India, anyway most of them are next to no including different area pharmacies that compound trimmings to make their own specific fixes . It is evaluated that the total assessments of things outline the entire Patanjali creation in India is on the solicitation of the one billion dollars (U.S.). the business has been directed by the not however much twelve critical associations for an extensive time allotment, joined actually several other have taken after their lead, so that there are today 30 associations doing 1,000,000 dollars or more for consistently in business to deal with the creating interest for Patanjali drugs. The consequences of these associations are fused inside the overall order of FMCG. Most of

greater Patanjali drug suppliers give materials other than Patanjali internal solutions, explicit in the districts of sustenance and toiletries. Where may be cover with Patanjali, for example, having customary local trimmings in the design of toiletries? There are such countless organizations in India, which are working in the field of Patanjali. Yet, Patanjali restricted has channelized their items not just in the field of Patanjali wellbeing items in FMCG just as materials as well. To upset up unfamiliar FMCG organizations in India they are attempting to give items to Indian customers at similarly ease with the best quality. Purchaser conduct toward explicit items relies upon different components like social factor for example Culture, subculture, and social class. Gatherings of people for example Reference gatherings, family and their job and status. Individual variables for example age, occupation, monetary condition, way of life, and character.

### 3. Research Methodology

#### 3.1 Objective of the Research:

1. To Study the customer choice of selecting Patanjali products
2. To Study the worldly idea of shopper work behind of selecting Patanjali Products
3. To know the various usage in Patanjali products

#### 3.2 Research Type: Descriptive research

#### 3.3 Data Collection:

**Primary data:** Primary data was collected from those people who are using Patanjali products.

**Secondary Data:** Secondary data has been collected from various secondary sources like Journals, magazine, articles, and other sources.

#### 3.4 Sampling Method: Researcher used convenience sampling method to collect data.

**3.5 Data Collection Tool:** researcher collected data through structured questionnaire filled by the respondents from the population.

**3.6 Statistical tools Used:** Research has applied percentage analysis and Chi-Square test to know the relationship between a dependent variable and an independent variable.

### 4. REVIEW OF LITERATURE

Once the relevant information about the product or service is obtained the next stage involves analyzing the alternatives. **Kotler and Keller (2012)** consider this stage as one of the important stages as the end user considers all the types and alternatives taking into account the factors such as size, quality and also price.

The Indian Ayurveda medicine market is not as popular as the allopathic medicine market for various reasons. This article intends to throw light on the performance, perceptions, and judgments about an Ayurveda medicine brand 'Patanjali' – a creation of Baba Ram Dev, who is a dynamic character in the media also for his periodic sensational statements about the current happenings in the nation, which hit the headlines quite often **Dr. A. P. Pednekar (2015)**.

**S. Deepika and S. Ambu (2017)** Today's end user wants to know what they can use for their life or what opus of the products, this curiosity of the end user oppressed by the Baba Ram Dev, has

to maintain and sustain the quality of own products along with its fastest-growing volumes in the Indian market.

Today's end user are more health conscious and are maintaining a good quality life, and their preference to consume such products which give them a good state of their health as well as provide maximum pleasure, the end user familiarity discipline leads in providing 'best total solution' an affirmation that the company helps its end users recognize their truthful problem and the best solution, ultimately taking charge of implementing it, Baba through his product offerings addresses all three value disciplines offering a unique blend of Ayurveda and Vedic philosophy to provide value for his customers (R. Priyanka, 2016).

### 5. Data Analysis

Demographic	Variable	Frequency
Gender	Male	32
	Female	88
Age Group	15-20	10
	20-30	67
	30-50	45
	50-60	5
Profession	GVT Job	23
	Business	46
	Profession	57
	Other	25
Income	< 10000	15
	11000-50000	20
	51000-70000	51

The age groups of respondents, 67% respondents belong to the age group of 20-30 Years, 45% belong to 30-50 yrs, 10% belong to 15-20 yrs, and only 5% belong to 50-60 yrs age group. 57% of respondents are having their own profession, 46% of respondents are having their business, and 13% are government job. Monthly income of respondents. 51% of respondents belong to 51000-70000 PM group, 20% of respondents have 11000-50000 PM, whereas only 15% of respondents have monthly income of 10000.

### 6. Hypothesis

H0: emotional and behavior traits play a significance role in selection of Patanjali products

H1: emotional and behavior traits does not play a significance role in selection of the Patanjali products

H0: the general division policy and consumer focus strategy play a significance role in the selection of Patanjali products

H1: the general division policy and consumer focus strategy does not play a significance role in section of Patanjali products



## 7. Sampling methods and size

I have selected the Strategic sampling beneath the designed sampling method, the basic elements studied are mainly the customer visiting the Patanjali stores. Scale use for measure- For measuring, I preferred to use Likert Scale.

## 8. Findings and Analysis

### A. Discoveries identified the customer choice of selecting Patanjali products

1. 48.4% of the responders strongly supported that they are strongly paying attention on manufacture in the state itself for a particular goods and services; it may be accessible at low or high cost
2. 26.00% of the responders partially supported, that they are supporting the statement, but the circumstances may affect the selection of the particular product and services, but if they meet with their obligation at some stage towards the services or good they like to buy the product, which manufactured in their mother land.
3. 12.42% and 15.52% they come under the difference, again which does not means that they are not nationalists, may be this affect error of the questionnaire design or statement formation.

### B. Discoveries Identified with the Wellbeing Cognizance

1. 41.8% of the responders are unequivocally supporting, this implies at any expense they are not bargaining with wellbeing when they will choose a specific item or administrations
2. 39.33% of the responders in part upheld, this implies at some occurrence may bargain with wellbeing because of current conditions and circumstance, when they are going for the choice of an item or administrations.
3. 10.1% of the responders are impartial, this implies they are not going for the current significant work first, yet this doesn't mean they are not thinking often about their wellbeing while at the same time choosing a specific labor and products.

### C. Discoveries identified with the quality seekness

1. 46.47% of the responders are firmly in help that implies they are not trading off with nature of the item or administrations, doesn't make any difference the expense of the item or administrations.
2. 33.6% of the responders are in help that implies they are quality searchers yet incidentally may bargain yet not constantly, while they are choosing an item or administrations.
3. 31% of the responders are nonpartisan that implies the vast majority of time bargains with quality dependent on the circumstance.
4. 8.8% and 20.67% of the responders falls under the conflict; it very well might be a reason for the blunder in outlining the poll or the dialects.

### D. Discoveries identified with the low Value seekness of the Shopper

1. 34.52% of the responders emphatically upheld, this implies they are saw low cost of item while they are going for purchasing labor and products.

2. 34.13% of the responders upheld, this implies they don't generally go at the determination of minimal effort of the item or administrations.
3. 10.4% of the responders are nonpartisan, with this they will buy items according to their need doesn't implies they are searching for cost of the item.
4. 26.1% and 25.02% responder's falls under the conflict, 16.1% chose that some time they purchase the items at low cost, however consistently they need to purchase items at significant expense.

#### **E. Discoveries identified with the materialistic nature of the Shopper**

1. 51.4% of the responders emphatically upheld, that implies they are materialistic in nature while the choosing an item or administrations
2. 33.3% of the responders in part upheld, this implies they don't generally show materialistic nature when they will purchase an item or administrations
3. 29.4% of the responders are unbiased in nature, at times shows the materialistic nature while choosing an item or administration
4. 6.8% and 8.78% responders are falls under the conflict that implies they are not materialistic in nature.

#### **F. Discoveries identified with the ingenuity of the Shoppers**

1. 57.7% of the responders firmly upheld, this implies they are imaginative in nature , in all ways they go for the new route for determination of the item or administrations
2. 24.57% of the responders part of the way upheld, that implies they not generally go for the new items or administrations
3. 25.32% of the responders are nonpartisan, this implies they don't generally go for the new item or administrations dependent on the circumstance
4. 5.4% of the responders in part dissent, that implies they sporadically go for the old item yet they are not limited for the item.
5. 4.08% of the responders firmly dissent, that implies they generally go for the old item accessible in market to purchase.

#### **G. Discoveries Identified with the Purchaser Center by patanjali Items**

1. 30.81 % of the responders firmly upheld , that PATANJALI Items more concentrations toward the purchasers
2. 28.43% of the responders in part upheld, that PATANJALI Items in part centers toward the purchasers
3. 15.17% of the responders are unbiased, that implies they can't say about the customer center by the PATANJALI Items
4. 10.27% of the responders somewhat dissent, that might be they go for the shopper center
5. 9.67% of the responders unequivocally can't help contradicting the purchaser center Theory testing H0:psychological and character qualities play an importance part in determination of

PATANJALI Items' merchandise or items For testing invalid theory, discover the normal of A,B,C,D,E,F and G.

1. 38.09875% of the absolute responders fall under obviously upheld
2. 26.77% of the absolute responders fall under moderately upheld

From above outcomes we can say that invalid theory passed. In this manner elective speculation consider to be fizzled.

H<sub>0</sub>:the broad conveyance strategy play an importance part in the choice of PATANJALI Items' merchandise or items

For testing invalid theory, discover the normal of C and G.

1. 35.73% of the all out responders falls under unequivocally upheld
2. 38.004% of the all out responders falls under incompletely upheld

## 9. CONCLUSION

Patanjali Items is one of the presumed organization in the field of Ayurveda drugs, it get success in more limited timeframe. It got sufficient popularity in India just as outside of the country. Patanjali Items used by the customer's their low cost seekness, common excitement, quality smoothness and other individual and mental characteristics. Which are become all the more amazing assets for the choosing choice of the buyer to purchase the products. With help of our discovering now we can say that the Coimbatore buyers are public and nature energetic in nature, wellbeing cognizant, great searchers, immaculateness searchers, low value searchers, materialistic in nature, creative in nature, while they buy customer solid items. And furthermore their purchasing conducts additionally affected by dispersion strategy and friends' purchaser center approach. In this manner I attempted to comprehend the business techniques received by the patanjali products and furthermore gave some information to the impending exploration on the Patanjali Ayurveda products.

## REFERENCE

- Arya Vikrant , Kumar Suresh , and Kumar Sanjeev (2012) “Consumer Buying Behaviour Towards Ayurvedic Medicines / Products In Joginder Nagar - A Survey” Ayurpharm Int. J. Ayuralli Sci., Vol.1, 2012,PP. 60 – 64
- Kumar, V., Jain, A., Rahman, Z., & Jain, A. (2014). “Marketing through Spirituality: A Case of Patanjali Yogpeeth”. *Procedia - Social and Behavioral Sciences*, 133, 481–490
- Singh Brijesh and Gopal R.K. (2016) “Demystifying the Brand Patanjali - A Case on growth strategies of Patanjali Ayurved Ltd.”. *PES Business Review*,/Vol. 11, ISS. 1, 2016,PP. 51-66
- Neal, C., Quester, P. and Pettigrew, S. (2006) “Consumer Behaviour: Implications for Marketing Strategy” (5th edition) Berkshire: *McGraw-Hil*.



**ACADEMICIA**  
**An International  
 Multidisciplinary  
 Research Journal**  
 (Double Blind Refereed & Peer Reviewed Journal)

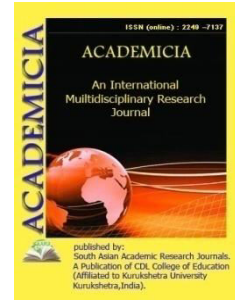

**DOI: 10.5958/2249-7137.2021.01860.7**

## PARADIGMATIC TYPOLOGY OF LEXICO-SEMANTIC VARIANTS OF THE WORD

**Dzhumanova D.R\***

\* Professor, Doctor of Philology,  
 State University of World Languages,  
 UZBEKISTAN

### ABSTRACT

*The emergence of new meanings in words or, conversely, the transition of any meanings to passive, is because of both linguistic and extralinguistic factors. Sometimes a new lexical meaning of a word arises in the name's transfer of one reality to another for various reasons. In the word's semantics itself, there are genuine opportunities for the development of a figurative meaning: hearth (family hearth), cream (society). The main difficulty in mastering vocabulary is not so much to comprehend and remember the word but to learn how to use it in speech. Each word should be overgrown with associative links, thanks to which it is recalled from memory and combined with other words. In the context, one or another meaning of a word is revealed, i.e., when combined with one or another circle of words, a given word appears in one meaning, combined with another circle of words, a lexeme appears in a different meaning, etc.*

**KEYWORDS:** *Monosemants, Polysemy, LSV, Lexemes, Phraseological, Consonant Sound, Lexical Position*

### INTRODUCTION

Monosemia has one meaning: window sill - a board or slab embedded in the lower part of the window opening; corduroy - dense cotton ribbed fabric with a thick short pile. Monosemy is such a quality of a word in which a word in discourse fully realizes the entire volume of the meaning assigned to it: sword, chintz, TV, electrification. It opposed monosomies to polysemantic words - words that have two or more meanings.

Polysemy is an incomplete realization in a speech of the entire volume of the traditional meaning assigned to a word. Using words in various lexica-semantic positions does not destroy its semantic, meaningful identity, but makes it possible to establish its individual meanings. Several



meanings are assigned to one word, and all these meanings are interrelated, the semantic relationship between different meanings ensures its unity. The semantics of polysemantic is a complex structured structure presented in different ways in different words. The meanings of a polysemantic word are in the relation of additional distribution, and there is a paradigmatic relationship between them.

The semantic structure of a monosemy is reduced to its seed composition. The simplest unit, an element of the content structure of a polysemant is its lexical meaning associated with other lexical meanings by certain relationships, the main ones of which are based on the hierarchy, on the expression of the subordination of the dependent lexical meanings of a word to the main one. In the semantic structure, words are connected with each other due to the common internal form, their mutual motivation, derivability of meanings from each other.

There is a strict relationship between the meaning of a word and the possibilities of its connection with other words. Word combination is a linguistic indicator of the meaning of a word. In the context, one or another meaning of a word is revealed, i.e., when combined with one or another circle of words, a given word appears in one meaning, combined with another circle of words, a lexeme appears in a different meaning, etc. The context, as a rule, usually eliminates the ambiguity of words, and it is thanks to the context that the communicative function of the language is possible.

Polysemy is one of the most important ways of grouping in the structure of a word. The unification of the variation within the framework of the polysemant occurs on the basis of their formal (sound, graphic) identity and different, but related meanings (seem):

Earth - 1) planet; 2) reality; 3) land; 4) soil, the top layer of the bark; 5) solid surface; 6) country, state; 7) territory, ownership; 8) the name of the various paints (special).

Life and language are constantly in development, which leads to various linguistic phenomena; a stationary system is symmetrical, evolving - it always includes something new, some options that express new or necessary meanings for a given situation and thereby violate strict symmetry, which is a manifestation of asymmetry. Variations, always associated with the expression of new meanings, appear and exist in the language, however, the equilibrium of the system tends to restore. This kind of fluctuation of a linguistic sign is one of the fundamental reasons for the phenomenon of formal differentiation of a lexeme.

The main meaning is the primary semantic function of the word, the particular meanings are its secondary semantic functions. Along with the usual dictionary meanings - the particular - in the semantic structure of the word, the general meaning is distinguished as its invariant, opposed to the variant meanings: this is the coinciding part of the content of all the meanings of the polysemant, something constant, unchanging in them. The ratio of the meanings of a lexeme to the general content of all its variants allows us to establish their semantic hierarchy according to closeness to it: the central, dominant meanings turn out to be semantically the simplest, while the peripheral meanings are more complex and therefore farther from the general, invariant meaning of the word than the former.

They associated the question of the typology of the LSV word with various grounds, including their syntagmatic and paradigmatic properties. The syntagmatic classification of V.V. Vinogradov, who distinguishes three main types of meanings: free (forest - 1) "a lot of trees

growing in a large space with closed crowns"), phraseologically related (a bosom friend), syntactically conditioned (My brother is a real beast) and constructively limited (playing football - play the guitar) [1, p. 162-189].

In the paradigmatic classification, semantic relations between LSV are described, based, according to L.A. Novikov, on the oppositions of exclusion, intersection, and inclusion [2, p. 203-205].

On the basis of exclusion, a purely semasiological one is distinguished, i.e. associative polysemy: audience 1) "lecture room" - audience; 2) "listeners of lectures, reports, speeches".

There is a semantic closeness of the LSV of many polysemantic, which is noted in the analysis of polysemy but is not associated with the peculiarities of paradigmatics, where this feature is the main property characterizing synonymous series: old - 1) old, existing for a long time, long: friend, 2) old, ancient: old book, and synonyms old: old friend, old: old book.

Polysemy is created in the following ways: a) over time, a word, at first unambiguous, can acquire a new meaning: manger - 1) animal feeder); 2) children's institution; guest - a visiting merchant, later a visiting (coming) person; b) there is a reduction in the concept (a city is something that is fenced off); the volume is narrowing (a German in the 17th century - not speaking Russian); kvass is an acid in general, a special drink; beer - any drink; nowadays beer is a certain drink made with the use of malt; c) there is an increase in the scope of meanings of words: weapons in the Old Russian language had the meaning of "stick, stake as a means of pain"; gradually this word began to call all types of emerging weapons. The word labor has a modern meaning "business, work", but it had an outdated meaning - "suffering, grief, illness" (difficult life); d) there is a change in the direction from a concrete meaning to an abstract (abstract) one: to grieve is bitter food; nonsense - in the 18th century - a sliver (ice breaks into nonsense from the wind); nonsense.

Sometimes there is a transfer of the name of an inanimate object, a sign into the human world and vice versa:

Black earth - black conscience

BLACK, oh, oh; black, black, black, and black. 1. Colors of soot, coal. C. crepe (funeral). Black pieces (in chess). Black eyes. Give black (nouns) as white (lie, distort the truth). 2. full f. Dark, in contrast. Chemoun. lighter, called white. Ch. Bread (rye). C. Mushrooms. Ch. Coffee (without milk). 3. Accepted a dark color, darkened. H from sunburn. Hands black with mud. Face black with grief. 4. full f. In the old days: the same as the chicken. Black bath. Heating in black (adv.). 5. transfer. Gloomy, bleak, heavy. Black thoughts. Black days. To depict something in black paint. Seeing everything in black light. 6. full f., transfer. Criminal, malicious. Black soul. Black treason. Someone did a dirty deed. Black forces of reaction. 7. full f. Not the main one, but the back one (about the entrance, the course). Black porch. Enter from the back door (also trans.: To bypass legal routes). 8. full f. About work: physically difficult and unskilled. Dirty work. 9. full f. Belonging to the underprivileged, exploited classes of society (obsolete). Ch. People. Black bone. 10. full f. Russia in 1217 centuries: state, not private. Black lands. Black peasants. 11. full f. Dark-skinned (as a sign of race) and black. The black population of the USA.

Steel knife - nerves of steel

STEEL, oh, oh. 1. see steel. 2. transfer. About color: silver gray. Steel waters of the bay. 3. transfer Very strong, sturdy (high).

Angry Man - Angry Wind

Evil, wicked, wicked; evil, evil, evil; angrier; worst. 1. Containing evil (in 1 and 2 meanings). H. intent. Z. rock (unhappy fate). 2. Full of anger, anger. Z. boy. Worst enemy. Z. look. Evil (adv.) Make a joke. 3. transfer. Causing severe nuisance, pain, burning; strong, extreme in the degree of its manifestation (colloquial). Angry longing. Z. frost. Bad mustard (very hot). 4. short. f., on someone. Angry, full of anger. Pissed off at everyone. 5. to what and to what. Doing something. enthusiastically, with passion (simple). Angry about work on or before work.

Affectionate mother - gentle waves.

LASKOVY, oh, oh; ov. Full of affection, expressing affection. L. child. L. look. L. wind (trans.).

The types of polysemantic are widely used in discourse, since they are bright and powerful means of creating expressiveness and imagery of the text, through the metaphorical and metonymic meaning of words and phrases, the uniqueness, individuality of objects or phenomena is conveyed. Metaphors serve as an important means of expressing the author's assessments and emotions, author's characteristics of objects and phenomena; the author's metaphors are often found in humorous and satirical texts. It is necessary to pay attention to the cases of using metaphors as an expressive means of figurative speech, when the author deliberately "collides" several meanings, deliberately drawing the attention of readers:

And a passion for poetry flared up in my heart, like smallpox flares up (Chekm.).

FLASH, well, don't you; owls. 1. (1 and 2 sheets not used). Flare up suddenly, ignite. A fire broke out. A light flashed. 2. (1 and 2 pages not used), translation. About feelings, shocks: to arise suddenly. Passion flared up. War broke out. 3. transfer. Suddenly become agitated, irritable. V. from resentment. B. with anger. 4. transfer. Blush (from excitement, embarrassment). V. for joy.

It (a miracle) appeared to Arkasha in the form of a middle-aged man in a soft ratin coat and with soft, intelligent manners (S. and Sh.);

SOFT [hk], oh, oh; gok, gk, gk, gk and gk; softer; softest. 1. Easily under pressure, compression, low elasticity, elastic. M. bread. M. sofa. Soft wool. Soft hair. Soft shoes. 2. It's nice to feel, not annoying. M. light. M. voice. 3. Smooth and measured. Soft movements. Step gently (adv.) Soft landing (about aircraft: at minimum speed). 4. Meek, devoid of rudeness, harshness. M. character. Make a mild comment. 5. Not very strict, condescending, not harsh. M. verdict. 6. Warm and pleasant. M. climate. 7. About water: low in calcium and magnesium salts, easy to wash off soap, not harsh (5 values). 8. full f. On vehicles: with soft seats or designed for soft seat use. M. Carriage. Soft reserved seat. 9. full f. About consonants: pronounced with the approach of the middle part of the tongue to the hard palate; against. hard (in 5 digits) (special).

In figurative speech, chains of metaphors, or expanded metaphors, are common. Such metaphors form words that in their direct meaning are closely related in meaning. When used figuratively, they create a number of interdependent, interconnected links:

"Curly lamb - the month walks in the blue grass" (Yessen.).

LAMB, nka, pl. nyat, nyat, m. Sheep cub. Pretended to be a lamb (pretended to be meek, gentle).

MONTH, ah, pl. s, ev, m. 1. The unit of time calculation according to the solar calendar, equal to one twelfth of the year (from 28 to 31 days); period of 30 days. Calendar m. (January, February, March, etc.). Vacation for m. For months (for whole months) does not write (for several months). 2. Thirty days dedicated to someone. public event, propaganda of something, month. 3. The disk of the moon or part of it. Full m. Sickle of the young month.

So, polysemy is linguistic wealth, a means of expressiveness. The main difficulty in mastering vocabulary is not so much to comprehend and remember the word but to learn how to use it in speech. Each word should be overgrown with associative links, thanks to which it is recalled from memory and combined with other words. This provision takes on particular relevance when enriching speech with ambiguous vocabulary. The polysemant is, as it were, a bundle of several meanings, LSV, which are semantically related to each other and realized in various typical contexts: Big - 1) significant in size, in size: big school; 2) large, important: big task; 3) an adult, grown-up: a big girl; 4) large family. In a certain context, the polysemant appears in one of its meanings, it is a consequence of the completely regular relationships of the given word with the words combined with it, i.e. is determined by the lexical position of the given word.

#### REFERENCES

1. Vinogradov V.V. Selected Works: Lexicology and Lexicography. - M., 1977.
2. Novikov L.A. Semantics of the Russian language. - M., 1982.
3. Ozhegov S.I. Explanatory dictionary of the Russian language. - M.: Russian language, 1978.



**ACADEMICIA**  
**An International  
 Multidisciplinary  
 Research Journal**  
 (Double Blind Refereed & Peer Reviewed Journal)

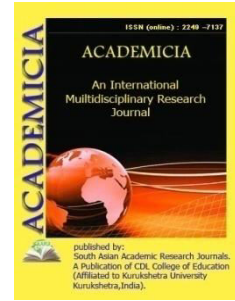

**DOI: 10.5958/2249-7137.2021.01861.9**

## IMPROVING THE METHODS OF TEACHING FOREIGN LANGUAGES IN PRIMARY SCHOOL

**Guli Orinboyeva Murodbekqizi\***; **Malika Raxmatullayeva Azimjonqizi\*\***;  
**Kamolova Umida Salomatqizi\*\*\***

\*Students of Faculty,  
 Primary Education at the YEOJU Technical Institute in Tashkent,  
 UZBEKISTAN

### ABSTRACT

*In recent years, the teaching of foreign languages to young learners, along with all subjects, has become increasingly important, especially in the pre-school education process, so the younger generation is This article focuses on the implementation of foreign language teaching from continuing education and its further improvement in primary education. In recent years, a new network of preschools is being formed. Examples are the Apartment Kindergarten and the Kindergarten-Primary School complex. Preschool education groups are being set up to teach children fine arts, music, language and computer literacy. On the other hand, just as every educator has his or her own method and method, they use these methods in the teaching process, but when appropriate, the method used by the foreign language teacher for any class does not apply to the next class.*

**KEYWORDS:** *"National Program of Personnel Training", creative and social activity, UNESCO, pedagogical innovation, ancient Turan, the Law of the Republic of Uzbekistan "On Education", KD Ushinsky, multimedia products, pedagogical innovation*

### INTRODUCTION

Nowadays, with the development of education and technology, there is a growing need to study and improve skills and work from one country to another, which in turn deepens the study of foreign languages. Therefore, the teaching of foreign languages, as well as all subjects, is becoming a key task in the educational process. At one time, our country needed to learn Turkish and Persian, Arabic and later, Russian and English, and similar languages in the land of Ancient Turan, which allowed citizens to speak this language independently. At the same time, one of the

main factors that every state should pay attention to is the development of education laws, which is tantamount to building a solid foundation. The National Training Program is one such law:

In accordance with the provisions of the Law of the Republic of Uzbekistan "On Education", the "National Training Program" is based on the analysis of national experience and achievements in the education system, worldwide and high general and professional culture, creative and social activism, the formation of a new generation of personnel capable of independently pursuing the goal in socio-political life, able to advance and solve future tasks.<sup>1</sup>

As mentioned above, at the heart of these goals is the idea and task of educating young people to be educated, conscious and qualified. In recent years, a new network of preschools is being formed. Examples are the Apartment Kindergarten and the Kindergarten-Primary School complex. Preschool education groups are being set up to teach children fine arts, music, language and computer literacy. Such actions serve the spiritual and moral education of preschool children in accordance with the requirements of the "National Training Program".<sup>2</sup>

Here's a look at the history: As one educator put it, "If a student doesn't have the desire to learn, all our dreams, research, and inventions will be wasted." The student's passion begins with the first step on the doorstep of the school, the primary classroom, and it is the primary school teacher who inspires the passion.<sup>3</sup>

At present, the identification of students' passions and interests, and the first step in this direction, is carried out from the very beginning of preschool education, and from this day onwards reflects the demand for education. K.D. Ushinsky, on the other hand, praises the morale and professionalism of teachers and argues that it is expedient to constantly improve their professional skills. The system that affirms the social significance of this idea is the first to establish a teacher training system.<sup>4</sup>

According to the Resolution of the First President of the Republic of Uzbekistan dated December 10, 2012 "On measures to further improve the system of learning foreign languages", these goals include teaching children a foreign language from the 1st grade. The training function has also been added.

The Resolution of the Cabinet of Ministers of the Republic of Uzbekistan dated May 19, 2021 "On measures to effectively organize the promotion of foreign language learning" also speaks about bringing quality activities to a new level.<sup>5</sup>

1-Ministry of Higher and Secondary Special Education of the Republic of Uzbekistan Termez State University, Department of General Pedagogy, Theory of Pedagogy, Part 1, Termez-2013; 2-that source; 3-Development and implementation of methods to accelerate the teaching of foreign languages in primary school - BT-Jurnal.uz; 4-that source; 5-- <https://bt-jurnal.uz/2020/05/23/problems-of-creation-and-introduction-of-methods-of-national-learning-learning-translation-in-first-classes>; 4- "GENERAL PEDAGOGY" TEXTBOOK, R. A. Mavlonova, N.H. Rahmonkulova, K.O. Matnazarova, Tashkent-2014 P.Q.Xolmatov, M.K.Shirinov



All the laws are aimed at improving education, training teachers, improving the quality of teaching and are being implemented in practice, and once the interests and needs of students are identified, the school and the teaching staff will be ready to work with students on a regular basis.

Learning about different countries, ethnic groups and their languages is one of the most interesting activities for students:

First, as students learn languages, they learn about the history, customs, and geographical location of peoples, which further expands the horizons of young children and, as a result, they gradually begin to apply them to their lifestyles;

On the other hand, just as every educator has his or her own method and method, they use these methods in the teaching process, but when appropriate, the method used by the foreign language teacher for any class does not apply to the next class. It is possible that sometimes foreign language teachers, whether they are the class teacher or not, are not talking about language concepts during the lesson, but about the national games, attractions, and, if necessary, national legends and tales of that nation. And many students will have an understanding of their future profession, i.e. if language teaching is strengthened in this way, it will be one of the first steps for them to choose a profession;

The third aspect is to be productive, to prepare for various competitions, science olympiads, to communicate with 10 students, to participate in such training only 3-4 times, first of all to learn the language, mathematics or will be the turn of technology science students, each student shaping his or her own identity to see everyone's worldview in family and national spirituality.

The educator uses a variety of methods to work with the class, and he or she can refer to many objects, one of which is technology. Technology is mainly effective in education, multimedia products, DVDs and CDs can lead to learning by watching and listening to a particular language, such materials are taught within a certain boundary between lessons, ensures that the lesson is not limited to a lack of teaching resources.

Pedagogical innovative processes in the West have been specifically studied by scholars in our country since the late 1950s and over the last 10 years. The interest of the world pedagogical community is in the form of special innovative services, publishing houses, magazines and innovative articles. In particular, UNESCO has the Asian Center for Pedagogical Innovation for the Development of Education, which summarizes pedagogical innovations from around the world and disseminates information about them in special publications to the pedagogical community in cooperation with the International Bureau for Education.

In conclusion, in addition to nationalism, it is necessary to educate students about world development, the language and culture of different peoples. The common understanding of the community of nations, the bonds of national friendship, religious respect, and the world emerges only after perfect public education, and this is one of the tasks before education.

#### **SOURCES USED:**

1. Ministry of Higher and Secondary Special Education of the Republic of Uzbekistan Termez State University, Department of General Pedagogy, Theory of Pedagogy, Part 1, Termez-2013;

2. Development and implementation of methods to accelerate the teaching of foreign languages in primary school - BT-Jurnal.uz;
3. <https://bt-jurnal.uz/2020/05/23/problems-of-creation-and-introduction-of-methods-of-national-learning-learning-translation-in-first-classes>;
4. "GENERAL PEDAGOGY" TEXTBOOK, R. A. Mavlonova, N.H. Rahmonkulova, K.O. Matnazarova, Tashkent-2014 P.Q.Xolmatov, M.K.Shirinov

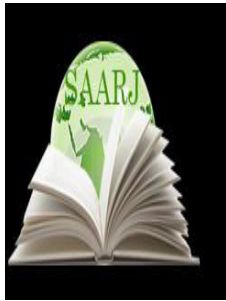

**ACADEMICIA**  
**An International**  
**Multidisciplinary**  
**Research Journal**  
 (Double Blind Refereed & Peer Reviewed Journal)

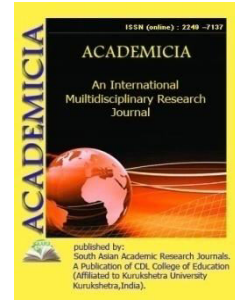

**DOI: 10.5958/2249-7137.2021.01862.0**

## LINGUISTIC INTERPRETATION OF THE EPITHET IN FRENCH

**Vazirakhon Mirzaeva\***

\*Lecturer at the Uzbek State,  
 University of World Languages,  
 UZBEKISTAN

### ABSTRACT

*This article examined the opinions of linguistic scientists about the history of the formation of an epithet as a stylistic means of expressing reality. Conclusions are drawn from a comparative study of scientific works of several linguists on the definition of the meaning of the word "epithet". Later, the epithet becomes a favorite means of characterization. The frequent use of the epithet in speech, especially in artistic speech, is explained by the need to make up for the worn out elements of expressiveness in words. "Behind another epithet lies the accumulation of metaphors, comparisons and distractions, a whole history of taste and style in its evolution from the ideas of the useful and the desirable to the isolation of the notion of the beautiful."*

**KEYWORDS:** *Epithet, Stylistic Means, Means Of Characterization, Expressiveness, Tautological Epithets, Explanatory Epithets, Poetic Definition*

### INTRODUCTION

The epithet as a stylistic means of characterization has been known for a long time. The history of the development of this category can be presented in the form of three directions: rhetorical, psychological and logical.

This category was noticed in Ancient Greece and Ancient Rome, where rhetoric flourished. Although rhetoric did not deal with questions of theory, but only sought to teach people to write and speak correctly, some of the theoretical positions formulated by Aristotle in Rhetoric and Poetics were the basis of stylistic science and largely determine the modern understanding of some tropes. [1.5]

Aristotle and Quintilian spoke of the epithet as a word with a certain concrete meaning and having a function in poetry - decoration, and in prose - an expression of an additional characteristic. Quintilian said: "This is how the epithet adorns speech. Poets use it more often

and more freely. They are satisfied that the epithet fits the word to which it is attached, and we do not blame them for "white Zuls" or "wet wines." For orators, if the epithet does not add to the meaning, it turns out to be superfluous, but there are such epithets, without which speech is weaker".

Quintilian considered the main thing the figurative meaning of the epithet. Aristotle and Quintilian warned against misusing the epithet, which can make speech "confusing" and style "cold." As you can see, even then the epithet was perceived as a stylistic means, equally related to poetry and prose.

Later, the epithet becomes a favorite means of characterization. The frequent use of the epithet in speech, especially in artistic speech, is explained by the need to make up for the worn out elements of expressiveness in words. As Vandries notes, "expressiveness in expressive words wears out especially quickly. The word becomes dull, worn out. "And would like to resurrect such a word, revive it, draw attention to it. [2.136]

In folk poetry, an epithet is assigned to a certain word and creates a so-called permanent epithet, the latter merges with the word so that it becomes its property: the field is clear, the sea is blue, the maiden is red. In the 19th century, there is a "psychological" approach to the epithet. Potebnya, for example, believed that this or that stylistic phenomenon did not arise as such, but is a product of a certain stage in the development of thinking; he considers the entire development of language as a process of changes in the "internal form of the word." The epithet, Potebnya and his followers, were considered as a definition capable of returning the word to its forgotten inner form. Perhaps the most interesting statement about the epithet we find in the book by A.A. Potebnya "From notes on the theory of literature. Paths and figures": "Any definitive, decreasing the volume and increasing the content of a concept, brings this concept closer to concreteness; already ancient philosophers, like Quintilian, distinguish the epithet poetic from rhetorical, poetic definition from prosaic. The prosaic epithet makes a distinction, completely excludes a certain meaning from thought. For example, if there are two Dons, the great and the small (Donets), and of course only the first, then the great epithet, necessary for clarity, will be prosaic".

We should dwell on the study of A.N. Veselovsky, who came close to studying the epithet in its development. "Behind another epithet lies the accumulation of metaphors, comparisons and distractions, a whole history of taste and style in its evolution from the ideas of the useful and the desirable to the isolation of the notion of the beautiful." A change in style traditions affects a change in the nature of the epithet. Veselovsky wrote about the gradual loss of the main objective meaning in the epithet and called it "oblivion of the real meaning of the epithet, and its adhesion to the defined - the process of "petrification".

His classification of epithets is not much different from the traditional one. The division of epithets into 2 groups: explanatory and tautological, is based on the historical development of the epithet and on its logical analysis.

Tautological epithets are epithets that repeat the signs inherent in the word itself - defined: *white light, the sun is red, the sea is blue.*

Explanatory - based on some feature that can be considered "essential in the subject or characterize it in relation to the practical goal and ideal perfect

This division looks somewhat contradictory if we turn to the very definition of the term of the epithet in Veselovsky. "An epithet is a one-sided definition of a word that emphasizes some characteristic, outstanding quality of an object." The main flaw in Veselovsky's research, as Mikhail Lopatto notes in "An Experience of Introduction to Prose Theory," is an incomplete definition of the term itself.

His classification of epithets is not much different from the traditional one. The division of epithets into 2 groups: explanatory and tautological, is based on the historical development of the epithet and on its logical analysis.

Tautological epithets are epithets that repeat the signs inherent in the word itself - defined: white light, the sun is red, the sea is blue.

Explanatory - based on some feature that can be considered "essential in the subject or characterize it in relation to the practical goal and ideal perfection".

This division looks somewhat contradictory if we turn to the very definition of the term of the epithet in Veselovsky. "An epithet is a one-sided definition of a word that emphasizes some characteristic, outstanding quality of an object. The main flaw in Veselovsky's research, as noted by Mikhail Lopatto in "An Experience of "Introduction to the Theory of Prose", is the incomplete definition of the term itself.

Many Russian linguists have studied the theory of the epithet without giving it a definition. Views close to those of Veselovsky regarding the development of the epithet are expressed by P.D. Pervov.

The scheme of development of the epithet can be imagined in parallel with the process of cognition of reality. Cognition occurs by generalizing the essential features and properties of objects. The epithet in this case repeats the root meaning of the word, which has become unclear over time.

In the case when the cognitive process highlights some essential feature of the object, the epithet contributes to the expression of the selected feature, and then it is the result of the semasiological process.

The "logical" point of view on the epithet is expressed in the works of Gornfeld and Tomashevsky. Gornfeld, transferring logical categories to the grammatical definition, identifies the epithet with analytical definitions. He writes: "The epithet - the beginning of the decomposition of the merged complex of representation - highlights the feature already given in the word being defined."

From this definition it is clear that the epithet is considered as a "sign" revealed analytically from the quality of the object. This narrows the concept of an epithet as a stylistic phenomenon. Gornfeld's merit is that he historically considers this category: "The history of the epithet is the history of not only the poetic style, but also the entire poetic consciousness from its physiological and anthropological principles, to their enslavement in the ranks of formulas."

Based on the theory of A.A. Potebnya, Tomashevsky builds his own concept of the epithet and includes it in the "Trope" section. "An epithet, he writes, is a so-called feature that accompanies a word ... This is the most common type of grammatical definition." [3.34]

Further, he interprets it as a definition that leaves the scope of the concept unchanged and does not expand its content – “The epithet does not add anything to the content, it seems to regroup the features, pushing into the clear field of consciousness that feature that might not have been present.”

B.V. Tomashevsky expresses a concept close to that of I.P. Lyskov, who also wrote that “the scope of concepts with and without an epithet remains the same.”

According to Lyskov, an epithet serves to create a vivid idea of an object on the basis of one characteristic feature that stands out among many others. The positive, in our opinion, is that Lyskov does not equate the epithet with the grammatical definition. We fully share his idea that epithets and definitions are in different planes: an epithet is a stylistic, complex and multifaceted term, often depending on extralinguistic factors, the definition is grammatical. Any epithet is at the same time a definition from a grammatical point of view, therefore, the very formulation of the question of whether an epithet can or cannot be identified with a definition seems to us unreasonable.

As already noted, the French term "epithet" is used by different authors with different meanings, then in the meaning of "adjective" then "attribut", then "determinatif". Therefore, it is important to emphasize that an epithet cannot be equated with a "definition." From our point of view, an objection is raised by the following statement by Lyskov "... for every significant part of speech there may be an epithet." In grammatical terms, the definition always refers to a word with an objective meaning, therefore we consider an epithet as a word referring to a noun.

It should be noted that great attention was paid to the epithet in linguistic literature, but each researcher interpreted it in his own way and put his own content into this word. V.N. Zhirmunsky, in his article “On the question of an epithet, proposed to distinguish between an epithet in the “ broad sense of the word ”and an epithet in the “ narrow sense of words ”. By the first, the author understands any definition highlighting “an occasional feature that captures one of the particular aspects of the phenomenon”, and by the second, a definition that repeats the feature that is contained in the word itself. Some linguists were interested in particular issues related to the evolution of the epithet “an epithet is the result of a semasiological process.”

Considers an epithet in connection with its function in a sentence and does not clearly define it. “An epithet is an apt word” or “A poetic definition is what an epithet is.” Of the various types of epithets, MD Rybnikova mentions a permanent epithet, a favorite epithet and a complex epithet. "Emotionally colored" epithets. [4.105]

Many works and articles are devoted to the functions of the epithet in the works of writers, including the aesthetic function. In these works, the epithets are differently classified into: general linguistic and individual. By means of a general linguistic epithet, a transition is made from the general to the particular, from the abstract to the concrete, since the epithet limits the meaning of the noun being defined, thus the lost figurativeness of the word is replenished. Individual epithets are considered the property of the writer's style. Professor Mandelstam in his book "On the nature of Gogol's style" put forward the division into objective and subjective as a classification principle, understanding by an objective epithet the expression of a feature objectively inherent in an object, while a subjective epithet is created under the influence of the writer's mood and is a kind of metaphor. Such a classification, it seems to us, does not accurately express the nature of the epithet.



Recognition of functional stylistics as "a linguistic science that studies the features and patterns of the functioning of language in various types of speech ... makes it possible to study the functional tasks performed by this visual means, and also to clarify the scope of its use. In this work, an attempt will be made to summarize the already known data and analyze this stylistic tool, based on its informative and aesthetic significance. The choice of an epithet as an object for analysis is due to its pictorial and expressive function in communication. For a very long time, the epithet was seen as an artistic definition of a noun in poetry and fiction.

The use of an epithet to achieve aesthetic goals is not a monopoly of the functional style of artistic speech. The opera of the use of the epithet is very diverse and there is no reason to attribute it only to fiction, but it should be emphasized that its use is ambiguous in different functional styles.

Recently, a number of theoretical works devoted to the epithet have appeared; research was carried out on the material of the German and English languages. In novelism, the structural and stylistic features of the epithet have not yet been fully disclosed. Until now, there is no consensus on the essence of the epithet, its grammatical forms have not been determined, nor its role in the system of pictorial means of the French language.

#### **LIST OF LITERATURE:**

1. S.N. Sirovatkin. Znachenie viskazivaniya i funktsii yazika v semioticheskoy traktovke. V.YA. №5, 1973.
2. Sm. M.N. Kojina. K osnovaniyam funktsional'noy stilistiki, Perm', 1968, str.136.
3. Vinokur. O soderzhanii nekotorig stilisticheskix ponyatij, Sb. «Stilisticheskie issledovaniya» M., 1972
4. Galkino-Federok YE.M. «Sbornik statey yazikoznaniyu, Izd. MGU. 1968, str.105

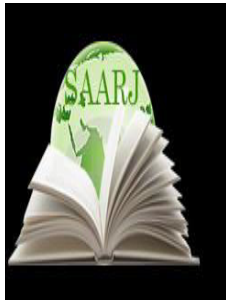

**ACADEMICIA**  
**An International**  
**Multidisciplinary**  
**Research Journal**  
 (Double Blind Refereed & Peer Reviewed Journal)

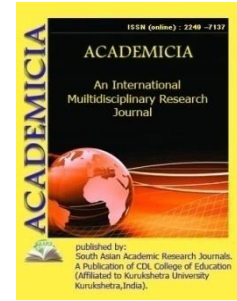

**DOI: 10.5958/2249-7137.2021.01863.2**

## FEATURES OF THE ETHNOCULTURAL MODEL OF FAMILY RELATIONS IN FAMILIES

**Amirkhojayev Shukurjon Kurbonovich\***

\*Senior Lecturer at the Department of Legal Education,  
 "The National idea, the foundations of spirituality and Andijan State University  
 UZBEKISTAN  
 Email id: amirhojayevshukurjon@gmail.com

### ABSTRACT

*In the article the author made an attempt to analyze the phenomenon of "family" through an appeal to the history of social philosophy. It is noted that the first attempts were discovered by the philosophers of Antiquity. Then the author gradually analyzes the ideas about the family in socio-philosophical views in subsequent historical epochs. As a result, the study made it possible to establish the moment of the object's study genesis, as well as to determine the continuity and development of conceptions concerning issues of research and theoretical comprehension of the family phenomenon. Key words: family, society, social philosophy, history, values, marriage, law.*

**KEYWORDS:** *Family, Socio-Philosophical, Society, Relations, Ethnos.*

### INTRODUCTION

To ensure social stability in society, special attention should be paid to the fulfillment of the functions of the family, and family members should be trained in the family and in the implementation of its functions.

The ethnic feature of social reality is not a set of statistical data (so many percentages, so many points). Moreover, it cannot be interpreted or classified as an instantaneous appearance, that is, as a pattern of behavior expressed in the form of a social process. Scientific reflection is a prerequisite for determining what functions ethnicity performs for the life of an integrated socio-cultural unit, community, society and society.

Considering that ethnicity is a sectoral polyparadigmatic field of science, it can be divided into universal and polyfunctional in terms of its characteristics. Ethnicity does not apply to either

formational or civilizational paradigms. In the form of classical and traditional explanations, it can also be described in terms of a stable dynamic and static model. After all, ethnicity is a norm that combines all the peculiar sights with different "colors" and expresses the originality of a certain logic, which should also be applied in social (including ethnic, professional) relations, the hierarchy of spatial ties, ethnicity, etc. the order of communication, the style of expression of national honor and national pride, ethnicity, ethnic unity and interests. It expresses in a synthesized form the hypostasis of individual feelings, grief, confidence and concern. Therefore, in a historical or situational context, there are cases when various social and political factors use ethnicity as "soft power" to achieve political goals.

Since ethnicity embodies ethnocultural content, it is theoretically more difficult to isolate it or present it as a separate group. But on the example of the institution of the family, this task is much simpler. Because one can understand the essence of the ethnocultural nature by observing the dynamics of family relations in families. An ethnocultural feature is the creation of material (a fortress, a city, tools of labor, etc.) sociocultural significance. This can be understood assimilation. It is necessary to take into account the manifestation and improvement of the spiritual and educational complex, which acts as a model of a way of life, justifying their unity of meaning and passing them on from generation to generation.

To ensure the maturity of a person, more precisely in the system of social relations, a realistic idea of ethnicity is necessary. To avoid conflicts and conflicts of interest. Only then can a new content (element) introduced into the system of relations play an educational role in the development of national characteristics. This content, in turn, requires special attention to the issue of family education in the practice of preparing our youth for an independent life. For this, educational institutions (centers) created in our country under the Ministry of Mahalla and Family Support will have to form a number of components, such as fatherhood, motherhood, bride, groom, in order to develop social competence in our youth. To do this, it is necessary to understand the essence of ethnicity, although ethnologists have identified its various components, in our opinion, the main components of ethnicity are:

- Origin (genesis) of the ethnos;
- Anthropological composition of the ethnos;
- Anthro-po-cultural changes of the ethnos as a result of assimilation;
- Migration processes (due to changes in the geographical area of the population in different historical periods, migration, war and famine, etc.);
- The form, content and style of relations within the ethnos (internal, ie, social differentiation);
- Preservation and active use of natural language in the ethnic group;
- Ensuring the relationship between modernized and traditional cultures;
- Expression of ethnic identity;
- Interethnic relations;
- Teamwork and competition in the process.

From a socio-philosophical point of view, it is necessary to approach this issue within the framework of the concept of "Homo ethnos". Because when studying family relations on the

basis of the concept of "Homo ethnos", attention is paid to a person as an ethnic being, that is, as a natural-biological and socio-cultural complex. The theoretical and practical significance of this lies in the fact that a person is given an attitude (in the form of social thought) to his home, social, professional life and activities in a certain place and at a certain time. Special attention is paid to the content - national consciousness. It is the national consciousness that expresses the characteristics of ethnicity and ensures the manifestation of ethnicity.

Each ethnic group differs from the other in its characteristic features. Those traits that should change within the framework of social relations (*mutatis mutandis*) are improved in a certain space and time. For example, egocentrism, groupocentrism and universal humanistic aspects in an ethnos are exaggerated during a communicative act and in one way or another affect the level of reliability of information transmitted in a humorous interpretation. Only a representative of this ethnos fully understands its essence.

Differences in historical time, social and cultural space and time have a significant impact on the culture of thinking, worldview and human attitude to events and processes. As an example, let us take A. Temur's views on marriage and the choice of a bride. "I focused on finding a bride because I was worried about getting married with my sons, grandchildren and relatives. I considered this work equal to the work of the state. I asked about the origin of the bride, about the seven roses. I learned about the health and physical maturity of ordinary people. As a bride, devoid of all shortcomings in pedigree, morality, health and strength, I arranged a big wedding for the people and drove the bride away," he said.

Although family relationships are historical and social variables of reference points and practices, the transformation that takes place between husbands and wives in relation to each other, to other family members, children and to certain sociocultural, economic and political processes in society is systemic. Deterministic paternal motherhood (as a separate system, although the family system is considered a subsystem) leads to a change in the phenomenon. This situation shows that positions are changing at the level of the relationship "Society - Family - Man". This, in turn, requires the following principles in planning and managing family life:

- 1) Human rights;
- 2) Gender equality;
- 3) Economic security;
- 4) The presence of different forms of families;
- 5) Family social policy.

Among the factors that threaten the stability of family life are suicides, the decline of family culture, the collapse of family values, an increase in divorce rates, an increase in the number of children born out of wedlock, an increase in the number of living orphans, factors that ensure family harmony (gift, cradle, scissors, etc.) .) Considering the decrease in the functional role, today's Uzbek family is fundamentally different from the families of the late XX - early XXI centuries.

**For example:**

- observed during the formation (construction) of a family. Such a social institution as a gift has lost its functionality. It was replaced by Dating Sites, Future Brides Club;
- The attitude of young people to the issue of marriage is changing in the form of economic autonomy, that is, their home, their place, there is a dominance of mercantilism. As a result, the institutional (legally contractual) approach to family and marriage is maintained;
- The nature of family relations has changed, and instead of love and affection, institutions such as a change in social status, reform of the way of life have appeared. As a result, there is a difference in the system of family values and personal values of the couple;
- The role of the mother-in-law, who at the normative level ensures family relations, is getting younger due to inexperience and a low level of social maturity. That is, mothers-in-law are not ready to fulfill their duties.

In the East, the family has long been considered the most sacred place and revered. The family as a social institution differs from other social institutions in that it performs functions such as the birth of a new generation, its improvement and support. But even in the destruction of this citadel, the influence of social factors is sometimes observed. According to the results of practical research, more than 140 thousand people and 35 052 families live in the Bulakbashi district of the Andijanregion, more than 200 new families are formed annually. In particular, if in 2018 1352 marriages were registered, then 213 families were divorced by law (15.8% of marriages) and increased by 64 or 42.9% (149-213) compared to the same period in 2017. That is, there is an increase in the dynamics of family disintegration. This indicator directly: tension in social relationships (between weddings, between neighbors, etc.); introduction of additional social protection, protection (social benefits, unemployment, etc.); without a father or mother, i.e. an increase in the number of illegitimate families and related additional problems.

According to statistics, the adoption of laws, financial assistance, registration, control is only an organizational and legal aspect, and the state, within the framework of its functions, implements measures to ensure the safety of life and activities of the population. But the socio-philosophical aspect of the issue lies in the fact that it is based on the personality, consciousness, culture and interests of the nation. Therefore, the philosophical study of the spiritual image of the Uzbek family in the late XX - early XXI centuries, the provision of targeted recommendations to young people, parents, social institutions, government agencies, theoretical participation in ensuring a sustainable social life is of scientific importance.

According to the collected data, 38 or 17.9% of families who divorced by court order were registered in previous years, and those who received a divorce certificate late. 71 of them were identified by the Women's Committee while walking around the apartment with the Family Center. It is clear that the divorce of young people is kept "secret" by parents or close relatives. They behave in such a way as to protect themselves from the negative formation of the mahalla, that is, public opinion, which does not correspond to their goal. This is because suicide and homelessness are associated with similar situations. Compared to 2017, this figure increased by 7% of ruling in 13 districts in Sanoat MFY, by 4.6% in ruling in 10 districts in Boy mahalla and by 3.2% from ruling in 7 districts in Zargaldok MFY. There is a negative trend. Based on the

review and comparative analysis of scientific sources, it is advisable to indicate the reasons for the decision as follows:

- Infertility (infertility of one of the spouses) in 18 (8.5%) cases;
- Family disputes (in the form of family disputes between spouses or mother-in-law) in 118 (55.3%) cases;
- 6 (2.8%) do not live together for a long time (go abroad to work, on a business trip, etc.);
- 5 (2.3%) for various reasons (marriage without love, a mistake in youth, etc.);
- 1 of them got married and has not yet married, that is, the object of love is chosen incorrectly.

The socio-philosophical problem is that 65 of them (30.5%) have not yet divorced, have not married in accordance with values, socio-cultural norms, have married another child and do not even have children. "According to statistics, forced marriages are unstable," he said. This is why couples can rarely be happy in a marriage built just because they are pregnant. " In our opinion, this situation can lead to the emergence of polygamy in society. This issue has its own story, and the author of the book "Family and Sharia Etiquette in Marriage" S. Mukhiddin also spoke about the influence of religious factors, the role of the environment. Therefore, we must be able to show that such cases are a negative flaw in this area. So young parents, young mother-in-law, young brides and grooms, more precisely, the future of our nation must be spiritually mature. Then a new generation of New Uzbekistan, creative Uzbek youth, will be formed. Leaving this question alone and focusing only on the legal and economic aspects can lead to the erosion of the components of our national culture.

The Uzbek people are well versed in the traditions of marriage, the choice of a groom or a bride, taking into account their social origin, role and prestige in society. If the mind, manners and beauty of the bride and groom are part of it, then their relatives, the position of the generation in society and public opinion in this regard are the second and often decisive factor. For Uzbeks, parenting, including mother-in-law and mother-in-law (according to the Eastern concept), requires the performance of a number of functions. This, in turn, indicates that their goals will also be different. As the main functions of the parent: birth of a child; caring for children, that is, meeting the needs for physiological knowledge and communication; create the necessary conditions for the development of the child, that is, to be an example, as the owner and carrier of cultural experiences; education and upbringing, that is, the transmission of the essence of the norms of everyday life, social life, basic knowledge; spiritual application, i.e. the manifestation of love and respect for the child (this duty remains until the end of human life).

Each cultural representative has focused on the issue of the physical, mental and spiritual development of their children, and this task, in turn, is entrusted to the parents. Therefore, since parents strive to ensure the maturity of their children, scientific and technical advances in various spheres of society and the intellectualization of the production process are widely used. For example, "How do you encourage your child to be successful in morality and excellence?" While 48% of parents living in the city indicated that they would pay for material or additional expenses, another 32% said that parents will receive spiritual support, praise, new books and participation in educational activities with their peers. free time. It can be seen that although the level of children's motivation for free time is relatively low (in%), it is known that these answers were given by parents with high family spirituality. Parents of families living in rural areas also



answered this question, saying: "I will be released from physical labor, I will pay for using the Internet." This shows that the territorial and cultural peculiarity also depends on the mental and cultural level of the parents. In Western culture, this socio-cultural feature is of particular importance, as S. Yan and K.Sh. showed, this approach is an important step towards ensuring the future of children. In our opinion, custody of children is the responsibility of the Uzbek family, which has always been the responsibility of adults in the family. In this regard, social control is a prerequisite for determining the process of growing up children in the family, so that they do not assimilate "mass culture". In his speech at the ceremony dedicated to International Women's Day 2020, President Mirziyoyev said: "If we want to educate future Khorezmians, Ferghans, Berunis, Bukharians, Ulugbeks, Navoi, first of all, we must educate healthy and good people." educated and spiritual mothers. " They have shown that ensuring the participation of mothers in this process, that is, achieving membership, produces effective results.

A.A. Akchurina, who studied the socio-philosophical characteristics of the family, writes that this indicator is a characteristic of respectable parents, and they clearly express a desire to convey their thoughts (words) in the form of harassment of children. It should be noted that even in traditional Uzbek families, the word of the father is of decisive importance, and it can be noted that in these families Islamic values are clearly expressed in family life. However, in modern families, the opinion of each family member is taken into account, and sometimes does not correspond to the general interests of the family. In our opinion, this type of relationship is characterized by a transition from traditional to modern, taking into account the values of each family member. The result is a gap between tradition and modernity. In the context of globalization, this can also be seen as the disintegration of family values. In particular, such experts as S. Otamuratov and G. Marramao especially noted in this regard. In particular, J. Marramao pointed out that globalization destroys all indicators of boundaries, democracy between worlds, eliminates internal and external divisions, and changes in meanings (values) are also observed. The institution of the family is no exception.

The family as a small group of society and social institution can be studied on the basis of various philosophical concepts. In particular, N.V. Bikbulatov and F.F.Fatykhova studied the life of the Bashkir family in the 19th-20th centuries - noted a decrease in the influence of moral views. Here it is necessary to take into account the influence of nationality, ethnogenesis, which has a direct impact on family life.

In the new Uzbekistan, the socio-philosophical empirical study of the Uzbek family is of theoretical and practical importance at a time when the human factor is valued and all state institutions work for the benefit of human life. To ensure social stability in society, special attention should be paid to the fulfillment of the functions of the family, and family members should be trained in the family and in the implementation of its functions. For this, it is recommended to create spiritual and educational groups on the territory of mahalla, taking into account ethnic and cultural characteristics and promoting the culture of family relations.

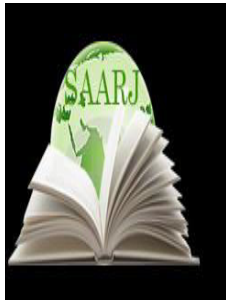

**ACADEMICIA**  
**An International  
 Multidisciplinary  
 Research Journal**  
 (Double Blind Refereed & Peer Reviewed Journal)

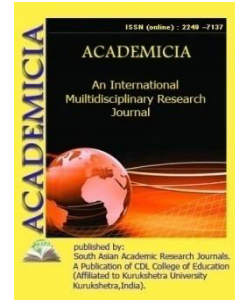

**DOI: 10.5958/2249-7137.2021.01864.4**

## EFFECTIVE METHOD FOR PHOTOGRAPHIC RECORDING OF HEAT FIELDS OF OBJECTS AND LASER RADIATIONS BASED ON A GAS DISCHARGE CELL

**Sharifa Bekmuradovna Utamuradova\***; **Khojakbar Sultanovich Daliev\*\***;  
**Zokir Khaydarov\*\*\***; **Dilmurod Abdujabbor ugli Rakhmanov\*\*\*\***

\*Doctor of Physical and Mathematical Sciences,  
 Director of Research Institute of semiconductor physics and microelectronics,  
 UZBEKISTAN

Email id: sh-utamuradova@yandex.ru

\*\*Doctor of Physical and Mathematical Sciences,  
 Executive Director of the National Research University,  
 "Moscow Power Engineering Institute" in Tashkent,  
 UZBEKISTAN

\*\*\*Candidate of Physical and Mathematical Sciences,  
 Research Institute of semiconductor physics and microelectronics,  
 UZBEKISTAN

\*\*\*\*PhD Student,  
 Research Institute of Semiconductor Physics and Microelectronics,  
 UZBEKISTAN

Email id: dilmurod-1991@bk.ru

### ABSTRACT

*This paper describes the design of a semiconductor photographic ionization camera used for spatio-temporal diagnostics of thermal fields of objects in the infrared wavelength range up to 30  $\mu\text{m}$  and beyond. The results of experimental studies of photo detectors made of silicon doped with platinum and sulfur in a semiconductor photographic ionization camera gas-discharge cell are presented. It is shown that high sensitivity of the photographic process is provided due to a new photographic effect, which is associated with the phenomenon of photoelectric hysteresis.*

**KEYWORDS:** *Diagnostics, Thermal Field, Laser Radiation, Photographic Effect, Photoelectric Hysteresis.*

## INTRODUCTION

Photographic methods of registration of thermal fields of objects and spatio-temporal diagnostics of infrared laser radiation is one of the promising directions of optical information recording [1-6]. In connection with the general intensive development of nanotechnological processes of creating photo detectors and their application in practical problems, the requirements for photographic registration of thermal fields of objects, as well as in the space-time diagnostics of laser radiation, have sharply increased. Among the numerous devices of infrared technology, a promising semiconductor photographic ionization camera [7, 8]. The use of the developed photo detectors in the semiconductor photographic ionization camera makes it possible to create a highly sensitive photographic system in the infrared region of the spectrum [9-12].

### Experimental part

The experimental setup is assembled from a semiconductor photographic ionization camera (Fig. 1, a) and a video control device of the AMJEON PRO UZB type (made in Korea). The photographed and observed object was the slit of an infrared monochromator with a NaCl prism and a "globar with a ferrite rod" light source. The slit image was projected with a BaF<sub>2</sub> lens onto the receiving surface of the photo detectors in the gas-discharge cell. The intensity of the radiation incident on the photo detector was determined by direct measurements with a metrological thermal column of the LETI type with a sensitivity of 0.72 V/W. The sensitive (to infrared-radiation) electrode of the gas-discharge cell are semiconductor wafers made of silicon doped with platinum and sulfur – *p-Si<Pt>* и *n-Si<S>* using a special technology.

The input side of the semiconductor wafers is equipped with stable ohmic contacts. The recording element in the gas-discharge cell is a fiber-optic washer having a diameter of 36 mm and a length of 22 mm, provided with a conductive SnO<sub>2</sub> coating. The fiber optic washer, in turn, is connected to the input of an electronic optical converter of the EP-16 type (made in Russia), and the output of the latter is mated to the input of the video control device. The generated image on the EP-16 screen is transferred to the computer monitor through the video control device. Thus, computer processing of infrared images is provided.

The initial cooling of the semiconductor photographic ionization camera cooler to 80 K is provided by liquid nitrogen, a further decrease in temperature is achieved by supplying liquid helium through a copper tube.

A high voltage of about 1200 V is applied between the semiconductor wafer and the fiber optic washer. The residual air pressure in the gas discharge cell is about 0.2 Torr. At the output of the fiber-optic washer, the invisible image is amplified using the EP-16, and then the video control device converts it into a digital signal. Thus, the photographic installation of infrared images assembled by us has a modernized look with the use of modern devices.

However, to record the output photographic characteristics in the experimental setup, a photomultiplier tube of the PMT-19A type was used. The output brightness on the EP-16 screen or at the output of the fiber optic washer was measured using a photomultiplier. Thus, in characteristic curves, the brightness of the infrared image is expressed in relative units proportional to the photomultiplier tube current.

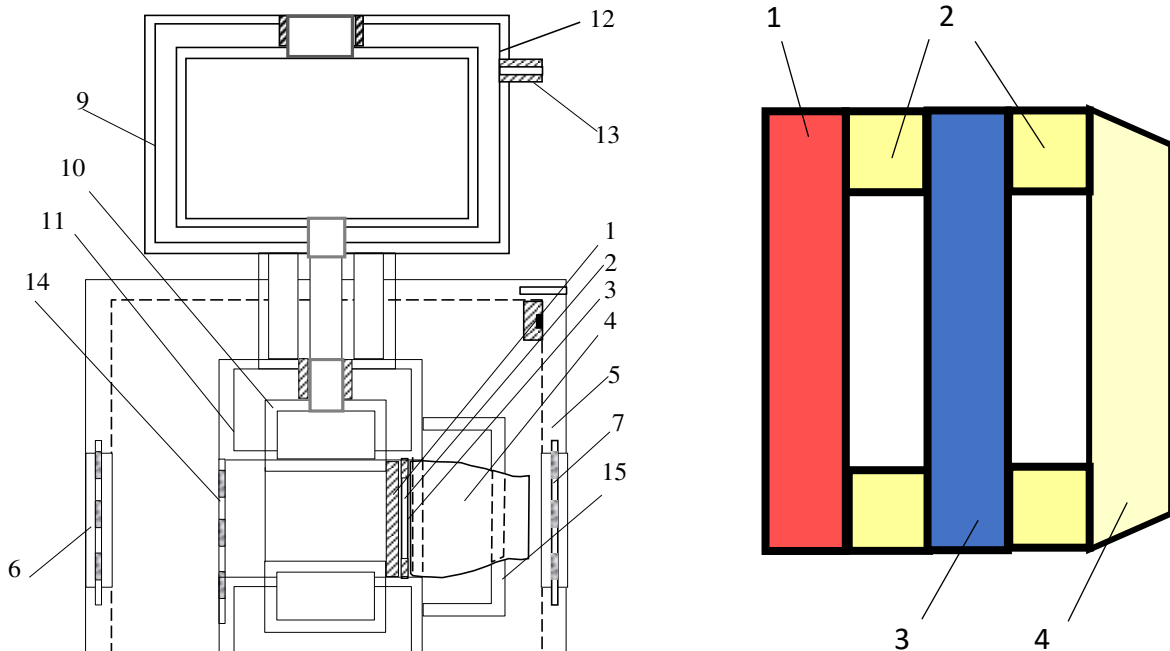

**Fig. 1, a.** Construction (schematically) of a semiconductor photographic ionization camera.

**Fig.1, b.** Gas discharge cell with  $n\text{-Si}$  photodetector and GaAs damping electrode. 1 -  $n\text{-Si}$  photodetector; 2 - mica plates with holes in the center; 3 - GaAs; 4 - fiber optic washer with  $\text{SnO}_2$ .

In fig. 1, and the following designations are adopted: 1 - annular cooler; 2 - gas-discharge cell (fig. 1, b); 3 - ohmic contact at the input of the fiber-optic washer made of  $\text{SnO}_2$ ; 4 - fiber optic washer; 5 - cover for replacing the semiconductor photographic ionization camera tooling; 6 - semiconductor photographic ionization camera input window; 7 - semiconductor photographic ionization camera output window; 8 - valve for pumping out and letting in air; 9 - dewar vessel; 10 - cavity for liquid nitrogen; 11 - evacuated casing; 12 - protective casing of the dewar vessel; 13 - valve for air evacuation; 14 - inlet window of the evacuated casing; 15 - fiber optic washer holder.

## RESULTS AND ITS DISCUSSIONS

To operate a photodetector made of  $n\text{-Si}$  at liquid nitrogen temperature and direct current, we changed the configuration of the arrangement of the electrodes of the gas-discharge cell. In this case, an  $n\text{-Si}$  was placed at the entrance of the gas-discharge cell, and then a GaAs electrode was placed through the gas gap and a fiber-optic washer was installed after the second gas gap (Fig. 1, b). In this configuration, GaAs plays the role of a damper (stabilizes the discharge combustion across the cross section), and  $\text{Si}$  provides photographic sensitivity to infrared radiation with a wavelength of up to  $11\ \mu\text{m}$  [13].

The experimentally investigated temperature dependences of the dark and photocurrents in a gas-discharge cell with photo detectors made of  $p\text{-Si}$   $\langle Pt \rangle$  [10] and  $n\text{-Si}$   $\langle S \rangle$  [12], respectively, are shown in fig. 2, a and b.

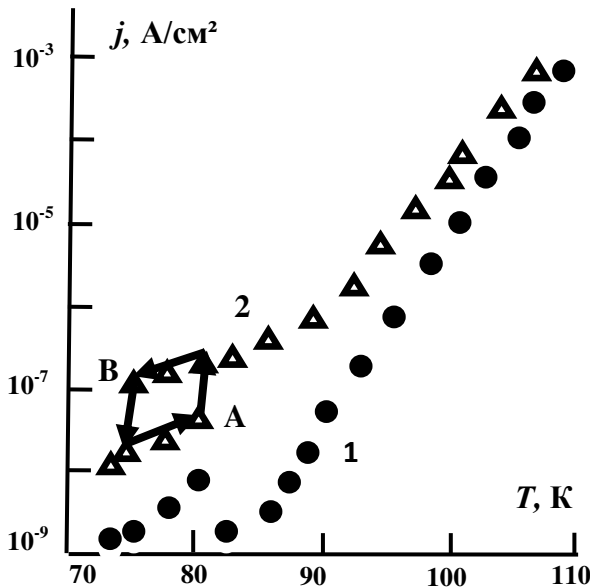

**Fig. 2, a.** Temperature dependences of the dark (curve 1 - black circles) and photocurrents (curve 2 - light triangles) in a semiconductor photographic ionization camera with a  $p\text{-Si}$   $\langle Pt \rangle$  photodetector.

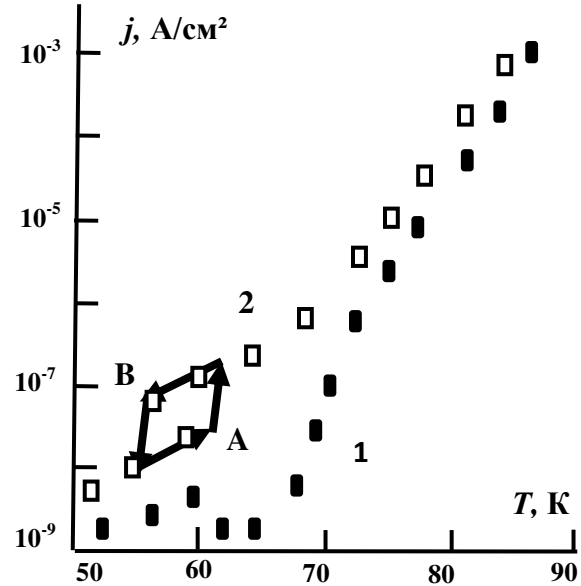

**Fig. 2, b.** Temperature dependences of the dark (curve 1 - black quadrilaterals) and photocurrents (curve 2 - light quadrilaterals) in a semiconductor photographic ionization camera with an  $n\text{-Si}$   $\langle S \rangle$  photodetector.

In the dependences of the dark and photocurrents, it was found that in the region of low temperatures ( $T = 80 \div 90$  K for  $p\text{-Si}$   $\langle Pt \rangle$  and  $T = 60 \div 70$  K for  $n\text{-Si}$   $\langle S \rangle$ ), there is an abrupt change in currents, and the dependence the photocurrent is normal, and the dark current is abnormal (Fig. 2, a and b). As can be seen from these figures, there is a hysteresis in the temperature dependence of the photocurrent (a loop circled by black arrows), the so-called **photoelectric hysteresis** in a gas-discharge cell, which leads to a photographic effect.

The photocurrent (curves 2 in Fig. 2, a and b) in the temperature range of  $\sim 80$  K has a jump up for a photo detector made of  $p\text{-Si}$   $\langle Pt \rangle$  and in the temperature range of  $\sim 60$  K - for a photo detector made of  $n\text{-Si}$   $\langle S \rangle$ , this is observed when the temperature rises along path **A**. When the temperature decreases along path **B**, that is, when the system is cooled, the photocurrent in the temperature range of  $\sim 75$  K drops abruptly for a photo detector made of  $p\text{-Si}$   $\langle Pt \rangle$  and in the temperature range of  $\sim 55$  K for a photo detector made of  $n\text{-Si}$   $\langle S \rangle$ . Thus, a photoelectric hysteresis associated with field emission is observed in a gas-discharge cell with a thickness of the order of  $40 \mu\text{m}$ .

## CONCLUSION

Note that the abrupt decrease in the dark current and the abrupt increase in the photocurrent are a new positive effect that affects the increase in contrast (multiplicity is the ratio of the photocurrent to the dark current), that is, the sensitivity of the semiconductor photographic ionization camera. The observation of a similar effect in different photodetectors and in different temperature ranges, apparently, has a natural character, which we call photoelectric hysteresis.

Thus, the effect of photoelectric hysteresis is a necessary condition for achieving high sensitivity of the photographic process in the semiconductor photographic ionization camera gas-discharge cell in the far-infrared region of the spectrum.

## REFERENCES

1. B. Pojot, C. Nand. J. Phys., 45, 539 (1984).
2. Л.Г. Парицкий, В.М. Тучкевич. Письма в ЖТФ, 11 (4), 197 (1985).
3. U. Kogelschatz, B. Eliasson, W. Egli. Pure Appl. Chem. 71 (10), 1819 (1999).
4. Ю.А. Астров, В.Б. Шуман, А.Н. Лодыгин, А.Н. Махова. ФТП, 42 (4), 457 (2008).
5. В.И. Орбух, Н.Н. Лебедева, Б.Г. Саламов. ФТП, 43 (10), 2009.
6. Ю.А. Астров, А.Н. Лодыгин, Л.М. Порцель. ЖТФ, 81 (2), 42 (2011).
7. З. Хайдаров, Х.Т. Йулдашев. Прикладная физика, 5, 75 (2016).
8. З. Хайдаров, К.З. Хайдарова, Х.Т. Йулдашев. Прикладная физика, 1, 65 (2017).
9. J.A. Pals. Sol. State El., 17, 1139 (1974).
10. И.А. Гук, Г.Б. Горлин, В.Б. Шуман, А.Н. Лодыгин, Л.Г. Парицкий, З. Хайдаров. Патент России, № 1672879, 22.04.1991.
11. S.D. Brotherton, M.J. King, G.J. Parker. J. Appl. Phys., 52 (7), 4649 (1981).
12. И.А. Гук, Г.Б. Горлин, В.Б. Шуман, А.Н. Лодыгин, Л.Г. Парицкий, З. Хайдаров. Патент России, № 1697572, 08.08.1991.
13. В.Т. Туланов, Х.Б. Сиябеков, А.Ш. Давлетова, К.А. Ортаева. ФТП, 35 (8), 1009 (2001).



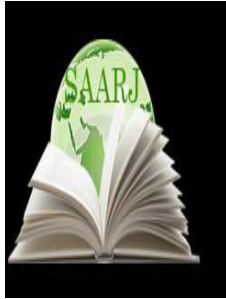

**ACADEMICIA**  
**An International**  
**Multidisciplinary**  
**Research Journal**  
 (Double Blind Refereed & Peer Reviewed Journal)

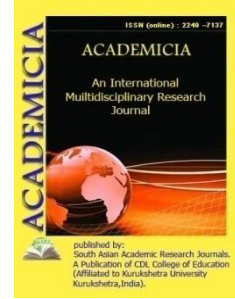

**DOI: 10.5958/2249-7137.2021.01865.6**

## STUDY OF EPIZOOTOLOGY OF TRIXOPHYTIS DISEASE IN COWS OF SAMARKAND REGION

**Shopulatova Zumrat Jahongirovna\* ; Usmonova Khadicha Juraevna\*\***

\*Associate Professor,  
 Candidate of Veterinary Sciences,  
 UZBEKISTAN

\*\*Doctoral Student,  
 Samarkand Institute of Veterinary Medicine,  
 UZBEKISTAN

### ABSTRACT

*This article examines the epizootiology of the origin of trichophytosis in cattle, depending on the season. In the research process, the distribution of the trichophytia fungus in cattle was highlighted in the cross section of the seasons. This is due to the wider development of international relations and the increase in animal exports. According to Rasulov's research in Uzbekistan in the 1970s, trichophytosis in cattle was exacerbated during the winter months, mainly in calves under one year of age. During the life of the animal, the diagnosis is made by laboratory examination of the fungus itself or its hairs under a microscope, taking into account the clinical signs of the disease, epizootiological data, age, type, and what type of fungus it has. Due to high humidity in the barns, the bottom of the cattle is filled with manure, the barns are not ventilated in time, pits and dust appear between the hairs of the cattle, the cattle are strongly disturbed and lick their outer bodies.*

**KEYWORDS:** *Cattle, Fungus, Microbe, Pit, Disinfection, Samarkand Region, Seasons, Epizootology.*

### INTRODUCTION

Currently, there is a trend of deterioration of the ecological situation, which leads to a decrease in immunity of animals and humans and, consequently, an increase in the number of mycotic diseases. Livestock is an important sector of agriculture in our country and plays an important role in meeting the needs of our people in livestock products.

Today, the demand for the development of pedigree cattle breeding is growing in the country. The main reason for this is the pedigree of cattle imported from abroad and the high level of meat and dairy products.

It is expedient to maintain this productivity, increase their breed and provide farms and the population of different regions and districts of the country with quality livestock.

For this reason, pedigree cattle imported from abroad are kept in quarantine for 40 days. The goal is to prevent various infectious and fungal diseases and prevent them from spreading to other regions. Unfortunately, due to non-compliance with quarantine rules on some farms, various infectious and trichophytic diseases are also on the rise. Despite the fact that veterinary measures are being taken, the incidence of trichophytosis (tetanus) in such cattle is growing every year. Given the fact that in veterinary practice so far no interregional scientific conclusions on trichophytosis in cattle, the main purpose of my research was to study the epizootiology of trichophytosis in cattle in the Samarkand region.

**Level of study of the problem:** Long-term observations show that the prevalence of *Trichophyton verrucosum* fungi can vary significantly. This is due to the wider development of international relations and the increase in animal exports. According to Rasulov's research in Uzbekistan in the 1970s, trichophytosis in cattle was exacerbated during the winter months, mainly in calves under one year of age. An analysis of the literature on tetanus published in the 1960s and 1970s found that the disease mainly began in August-September among calves, with trichophytia being more common in the fall and winter and less common in the early spring.

My research shows that the disease has been found to be more common mainly in the fall and winter seasons during 2018. In the spring and summer of the 2019 season, damage was observed in the form of coins. In 2018-2019, coin-shaped forms of trichophytia were more common in cattle of different ages, mainly in October in the fall, winter in December, spring in March-April, and summer in August.

**The purpose of the study:** Seasonal analysis of the fungal disease **trichophytia (tetanus)**, which occurs in livestock in the population and breeding farms.

**Materials and methods:** According to the research, in October, December, March, April, August 2018-2019 in the Arabkhana area of Pstdargom district of Samarkand region and in the village of Esavoy in the farm "Grant Farim", in the breeding farm "Yurti Risqi" LLC Kasbi district of Kashkadarya region when diagnosed with the disease in cattle appeared iron spots in the form of circles, circular shapes on the upper part of the skin. During the life of the animal, the diagnosis is made by laboratory examination of the fungus itself or its hairs under a microscope, taking into account the clinical signs of the disease, epizootiological data, age, type, and what type of fungus it has. It is taken from the injured area of each infected animal for inspection. Take 6-10 pieces of damaged wool fiber, put in a cup petri and add 5 grams of 10% sodium hydroxide solution. After 20-30 minutes, add a drop of 50% glycerin to the microscope instrument glass, collect 6 hairs on it, cover it with a thin cover glass and check the average size of the microscope.

**Trichophyton verrucosum** fungal examination was performed according to generally accepted methods.

**Inspection results and their analysis:** The research was conducted at “Yurti Risqi” LLC breeding farm in Kasbi district of Kashkadarya region, Iskandari, Bakkal, Ravot mahallas in Samarkand region, Jambay, Payarik and Pastdargom districts, and “Graent Farim” farm in Esavoy village.

At the “Graent Farim” farm, 33 Simmental breeds imported from Poland are in the meat and dairy category, weighing 550-600 kg. The cattles were delivered in late August.



Picture 1. Microscopic examination of the fungus *Trichophyton verrucosum*.



Picture 2. Appearance of an animal infected with the fungus *Trichophytia*

Until September and October, cattle are kept in outdoor pastures, left in the field during the rainy season, high humidity, insufficient suckling, lack of indoor barn buildings, lack of disinfection causes various diseases. Trichophytosis was observed on the farm in November, December, and January. As a result, the daily milk yield in such cows is reduced by 1-2.0 times in a short time, and body weight by 15-20%, in return for their decline in growth and development, the population and farms suffered great economic losses.

These barns were disinfected twice with supermethrin and chlorine mixtures, and butasol vitamin and ivermectin were injected to treat ***Trichophyton verrucosum*** disease. A mixture of adnachloriskiy and levamikol ointment was applied to the outer surface twice a day. The disease was cured in 10 days and productivity increased.

## CONCLUSION

The reason why the fungus *Trichophytia* is more common during these months is that there is a lot of rainfall during these seasons. As a result, the cattle stay in the barns during the day. Due to high humidity in the barns, the bottom of the cattle is filled with manure, the barns are not ventilated in time, pits and dust appear between the hairs of the cattle, the cattle are strongly disturbed and lick their outer bodies. After that, due to friction on the walls and bowls, the hair falls out, causing the development of trichophytia fungus due to the ingress of dust, gung, germs between the injured skin.

An important condition for the prevention of infectious diseases is the timely mechanical cleaning and preventive disinfection of inspectors assigned by the Committee for Veterinary and Livestock Development of the population and breeding farms of Samarkand region.

**LIST OF USED LITERATURE:**

1. Nurmatov UV Tulyaganov AR VIII All-Russian Congress of Dermatovenereology: Scientific Theses. Part 1 // Dermatology.- M, 2001. R. 154-155.
2. Karaboev D.K. To the question of epizootology of ovine paramphistamatoz in the Guryev region Kaz. SSR. In KN: K materials scientific. Proceedings of the Conference on the Problem of Helmentology, Dedicated to the 85th Anniversary of Akhod. K.I. Scrub. Samarkand - Tailak: 1963, p - 47.
3. Stepanova Zh.V. Kŷzikorin kasalliklari. Diagnostics, zamonaviy davolash usullari prevention. M: Kron-Press, 1996 y.-164b.
4. Salimov HS, Kambarov AA "Epizootology" Textbook., P. 2016, pp. 86, 96
5. V.Z.Bazaev, O.V. Dashevskaya, A.A. Fidarov, M.S. Tsaruyeva. A.V. Fidarov.
6. Methodical manual of trichomycosis (microsporia, trichophytosis, favus). Vladikavkaz; 2007.



**ACADEMICIA**  
**An International**  
**Multidisciplinary**  
**Research Journal**  
 (Double Blind Refereed & Peer Reviewed Journal)

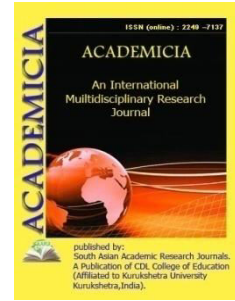

**DOI: 10.5958/2249-7137.2021.01866.8**

## SPIRITUAL AND MORAL CRITERIA OF STUDENT EDUCATION

**Abdullayeva Gulchekxra Abdullajonovna\***

\*Doctoral student of the Department of Pedagogy and,  
 General Psychology, National University of UZBEKISTAN

Email id: [gul.1986.abdullajonovna@gmail.com](mailto:gul.1986.abdullajonovna@gmail.com)

### ABSTRACT

*The article is devoted to the organization of spiritual and moral education and the criteria for assessing this process, with special emphasis on the criteria of spiritual and moral education. The basis of any progress is spirituality. And no one recognizes the "progress" in a place that is not irrigated by the spirit of spirituality. Therefore, the systematic nature of educational work in the school system is based on the spiritual chain and is based on the principle of humanity. The determinants of the concept of spirituality are multidimensional and multifaceted. Therefore, the qualification of the level of spiritual maturity of students is a problem that has not yet been studied and solved. . Through this system of collaboration, each student's uniqueness, interests, and needs can be explored and the stages of full control and development identified. The mechanisms of activity of the recipient are developed separately. The main purpose of spiritual and moral education on the basis of pedagogical cooperation is the correct formation of students' consciousness, worldview, psyche, rational needs, attitudes and behaviors through multifaceted influence and joint spiritual perfection.*

**KEYWORDS:** *Spirituality, Education, Assessment Criteria, Qualimetry.*

### INTRODUCTION

From the point of view of the great scholars, the basis of human existence is said to be the harmony of the three great powers. These are body (body), spirit and spirituality. The basis of any progress is spirituality. And no one recognizes the "progress" in a place that is not irrigated by the spirit of spirituality. Therefore, the systematic nature of educational work in the school system is based on the spiritual chain and is based on the principle of humanity. The main criteria for the development of collaborative pedagogy include such structures as teacher and student, teacher and parent, parent and student, student and student, educational institution and community, and student and intellectual council, which form the educational relationship in the



organization of spiritual and moral work in the educational institution. The mechanisms of activity of the recipient are developed separately. The main purpose of spiritual and moral education on the basis of pedagogical cooperation is the correct formation of students' consciousness, worldview, psyche, rational needs, attitudes and behaviors through multifaceted influence and joint spiritual perfection.

1-application

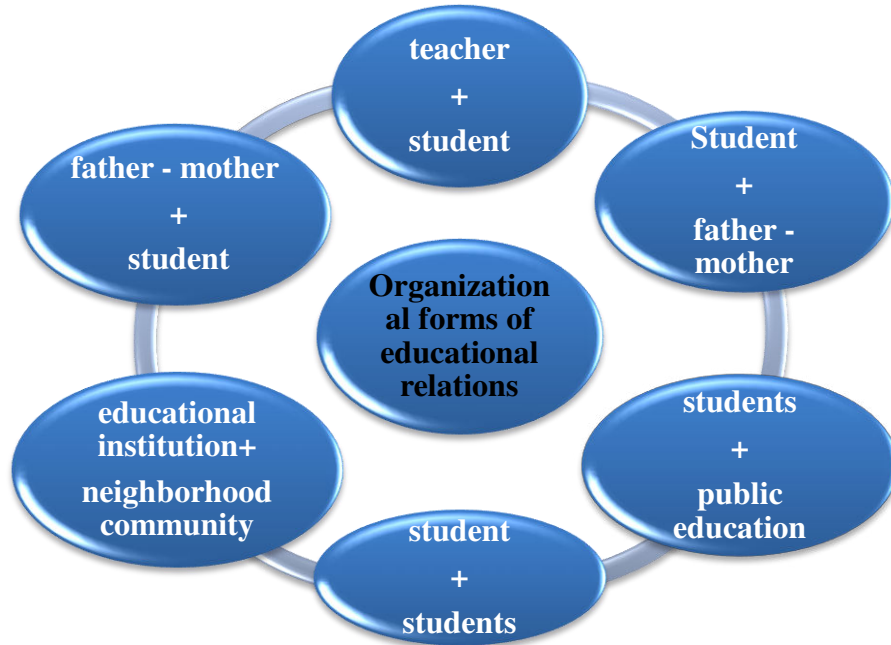

2-application

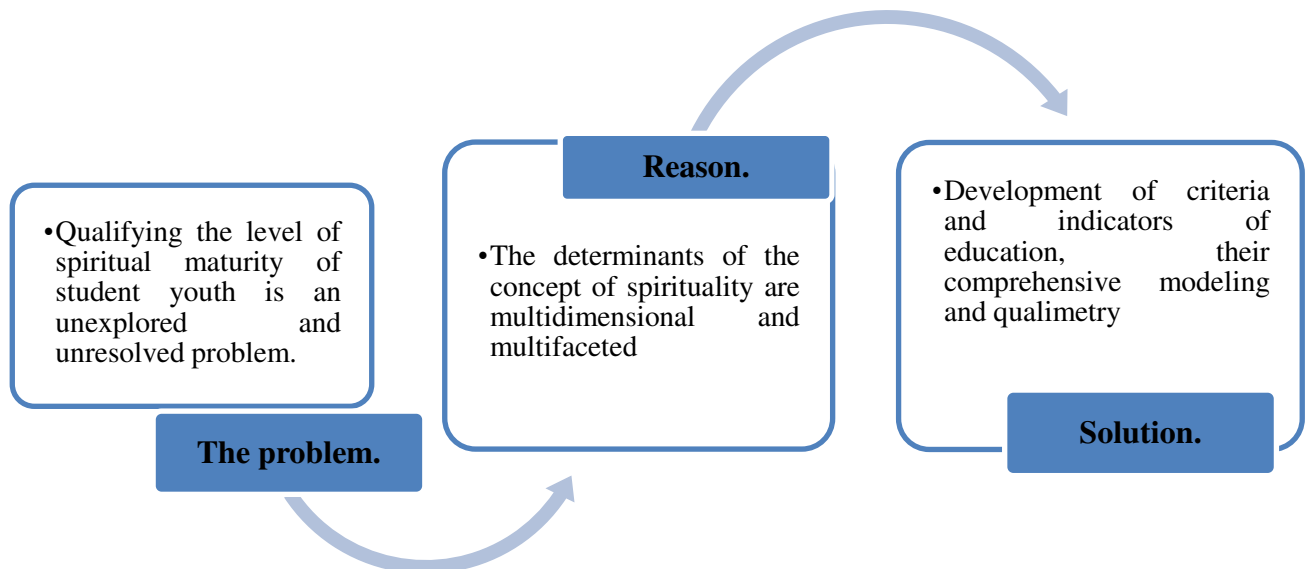

The determinants of the concept of spirituality are multidimensional and multifaceted. Therefore, the qualification of the level of spiritual maturity of students is a problem that has not yet been studied and solved. By developing criteria and indicators of education and modeling them as a whole, we can achieve the qualimetry of educational work. To do this, we need to define clear



indicators of the assessment of spiritual and moral upbringing, taking into account the national and modern features. The effectiveness of spiritual and moral education is manifested through the decision-making in students of many qualities and attributes that are more complex to develop.

Criteria	Indicators
The distinctive spiritual image of the students	<ul style="list-style-type: none"> <li>✓ Humanity</li> <li>✓ Striving for strong discipline</li> <li>✓ Good understanding of civic duty</li> <li>✓ The level of formation of moral culture</li> <li>✓ level of civilization of human relations</li> <li>✓ interest in reading, learning</li> <li>✓ Activity in team activities</li> <li>✓ Flexibility to new experiences</li> </ul>
Socio-cultural environment Assimilation	<ul style="list-style-type: none"> <li>✓ flexibility to the social environment</li> <li>✓ Development of worldview</li> <li>✓ communication culture</li> <li>✓ Knowledge of school rules</li> <li>✓ adherence to the norms of social life (moral culture)</li> <li>✓ Aspiration to work</li> <li>✓ Availability of artistic skills and creative abilities</li> </ul>
Social maturity of students	<ul style="list-style-type: none"> <li>✓ The idea of independence</li> <li>✓ social activity</li> <li>✓ self-confidence</li> <li>✓ independent selection</li> <li>✓ be able to make decisions</li> <li>✓ A sense of responsibility and accountability</li> <li>✓ Leadership ability</li> <li>✓ readiness for professional competition</li> <li>✓ scientific and creative orientation</li> <li>✓ Striving for self-development, self-education</li> </ul>
Formation of personal "I"	<ul style="list-style-type: none"> <li>✓ Ability to self-assess</li> <li>✓ Stability of interests</li> <li>✓ formation of reasonable goals</li> <li>✓ Development of initiative</li> <li>✓ Adoption of forward-looking plans</li> <li>✓ Self-esteem, dignity</li> <li>✓ Believe in their own strength and expand their capabilities</li> </ul>

Physical development	<ul style="list-style-type: none"> <li>✓ Good health</li> <li>✓ adherence to a healthy lifestyle</li> <li>✓ Ability to work</li> <li>✓ Follow personal hygiene</li> </ul>
Spiritual power	<ul style="list-style-type: none"> <li>✓ The ability to feel, to perceive</li> <li>✓ be able to regulate their feelings and emotions</li> <li>✓ Ability to positively influence the mood of others</li> </ul>
Intellectual, scientific skills	<ul style="list-style-type: none"> <li>✓ High level of mastery of sciences</li> <li>✓ Cognitive level</li> <li>✓ Achievements, successes</li> <li>✓ Research ability</li> <li>✓ Worldview and level of thinking</li> </ul>
Quality of knowledge	<ul style="list-style-type: none"> <li>✓ The richness of the scientific worldview</li> <li>✓ Awareness of modern knowledge</li> <li>✓ High performance in science</li> <li>✓ Participation in competitions and achievements</li> <li>✓ Positive dynamics of quarterly knowledge</li> </ul>

3-application

**Spiritual and moral criteria and indicators of students' upbringing**

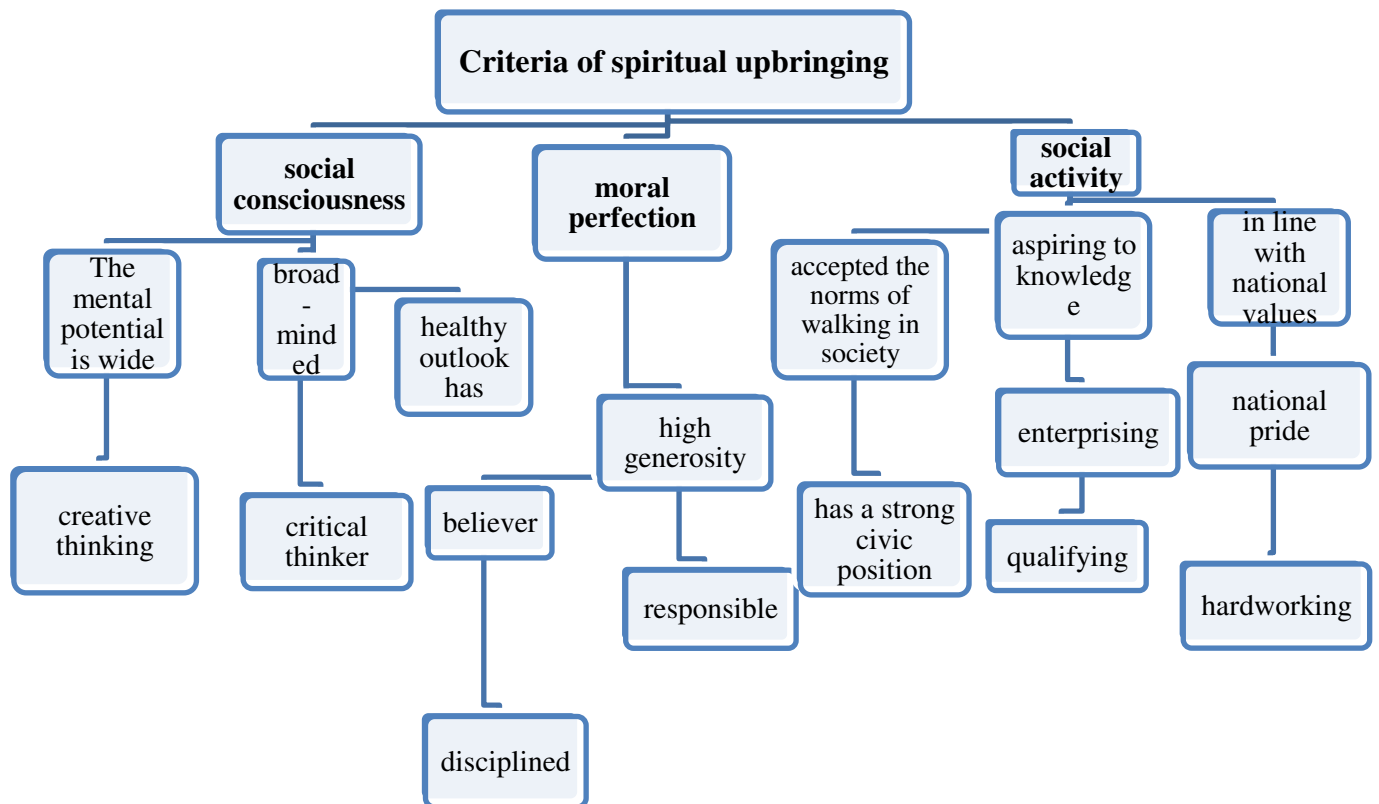

1. The unification of the educational institution, parents and the community is the only and effective way to educate students on a solid basis. Through this system of collaboration, each student's uniqueness, interests, and needs can be explored and the stages of full control and development identified. To do this, first of all, parents should feel that they are real members of the school education system, further coordination of educational work with the educational impact of the school will facilitate the development of the student's personality, the regular implementation of educational goals.
2. There is a great demand for teachers, especially class teachers, in the organization of spiritual and moral education:
3. Quick decision making in difficult situations;
4. Strictness and consistency in the organization of educational work of students;
5. To be very intelligent, fair and enterprising as a builder of the child's future;
6. All qualities and attributes of a teacher, such as eye expression, gait, dress, communication culture, speech, should ideally be exemplary.

**REFERENCES:**

1. Karimov I.A. "High spirituality is an invincible force" - T. Manaviyat, 2008.
2. Abu Nasr Farooqi. A city of noble people. –Т.: Fan.2016 y. -B.162.
3. Boytemirova Z. D. Factors shaping the moral needs of the individual. Fals.f.d. written dissertation for academic degree. avtoref.- T., 2008- B.60
4. Nomurotova M.Q. A philosophical analysis of the spiritual needs in the development of society. Fals.f.d. written dissertation for academic degree. avtoref.- T., 2017.B.40.
5. Muhammad Sadiq Qashqari. Good manners (Odob-as-salihin) .- Tashkent: Yangi asr avlodi, 2018. - P.32-40
6. Khudoykulov X.J. Criteria of spiritual perfection. -Т.: Dzayin –Press, 2019 y. – B.254.Худойкулов Х.Ж. Талабалар учун тарбиявий Толибнома.-Т.: Инновация – Зиё.2020 й.-Б.276.



**ACADEMICIA**  
**An International  
 Multidisciplinary  
 Research Journal**  
 (Double Blind Refereed & Peer Reviewed Journal)

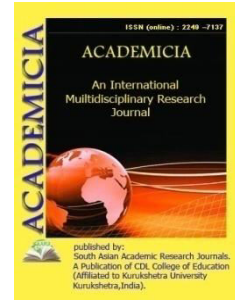

**DOI: 10.5958/2249-7137.2021.01867.X**

## ANALYSIS AND ASSESSMENT OF ANTHROPOMETRIC BODY MASS INDEX FOR WOMEN OF FERTILIZED AGE IN BUKHARA REGION

**Yakhyoyeva H.Sh\*; Rizaeva M.A\*\***

<sup>1,2</sup>Department of Internal Medicine and Endocrinology,  
 Bukhara State Medical Institute named after Abu Ali ibn Sina,  
 UZBEKISTAN

Email id: yahyoyevahilola@gmail.com

### ABSTRACT

*Changes in anthropometric indicators of body mass index (BMI, kg / m<sup>2</sup>) in young women are directly related to certain risks associated with both reproductive health and the outcome of subsequent pregnancies. Normal values are: BMI from 18.5 to 24.99 kg / m<sup>2</sup>; limiting: BMI <18.5 kg / m<sup>2</sup> and BMI > 30.0 kg / m<sup>2</sup> (thinness / obesity). Iron loss during menstruation is high - about 1.4 mg iron / day, which increases the average daily iron requirement in young menstruating women to 2.1 mg, compared with girls in the previous age group (before puberty). The largest proportion of women of normal weight (BMI 18.5-24.9) in the distribution of frequencies among all subgroups of young women of fertile age (18-39 years) - for the country as a whole, for rural and urban groups of the population, is established among women living in the city 59.6%.*

**KEYWORDS:** *Body Mass Index, Young Women Of Fertile Age, Risks, Anthropometric Status, Nutrition, Reproductive Health.*

### INTRODUCTION

The purpose of this work is to conduct an expert analysis and estimate BMI in women of fertile age in the Bukhara region.

The object of the study was 105 young women of pre-fertile and fertile age (18-39 years), who were subdivided by profession - worker / student, place of residence from the capital, from urban / rural areas.

**Methods:** A unified WHO methodology was used for measuring height and body weight, as well as for determining BMI = body weight in kg / (height in m)<sup>2</sup>, i.e. - kg / m<sup>2</sup>. Normal values are

considered BMI from 18.5 to 24.9, and limit values: BMI <18.5 and BMI > 30.0 (thinness / obesity). The analysis of a huge amount of data was carried out using a computer program and statistical methods.

## Results

Women aged 18-39 years in the general sample for the country as a whole with normal weight (BMI 18.5-24.99) accounted for 49.8%. Decreased body weight (BMI <18.5) was observed in 18.8%, and overweight and obesity (BMI over 25.0) were observed in 31.4% (including 19.6% - overweight, and 11.8% - obesity). The distribution of the BMI index depending on the place of residence - urban / rural areas, shows that the largest proportion of thin women (18.6%) are in urban areas, versus 12.3% for the same indicator in rural areas.

The largest proportion of women of normal weight (BMI 18.5-24.9) in the distribution of frequencies among all subgroups of young women of fertile age (18-39 years) - for the country as a whole, for rural and urban groups of the population, is established among women living in the city 59.6%. The lowest rate is for women from villages. For the country as a whole, the proportion of women of childbearing age with normal weight during the study was 48.6%.

Women from rural areas have significantly higher values of the proportion of overweight and obesity than their peers living in cities - 29%, compared with 17% ( $p < 0.001$ ).

Anthropometric indicators of nutritional status are important for assessing nutrition and general health of the general population, and especially women of fertile age. Deviations from the recommendations for normal weight - both in the direction of underweight and overweight, for women of childbearing age (18-39 years old) in the Bukhara region - at the national and regional levels are just as alarming.

In both cases, there is a health risk. This is a population group (young women) whose most important biological role is to bear and give birth to a healthy and viable fetus (1).

It is an indisputable scientific fact that the main etiological factor of underweight is malnutrition.

The problems are mainly related to:

- Protein deficiency;
- deficiency of B vitamins - folic acid, vitamin B12, vitamin C, iron, calcium and other essential biologically active substances.

Iron loss during menstruation is high - about 1.4 mg iron / day, which increases the average daily iron requirement in young menstruating women to 2.1 mg, compared with girls in the previous age group (before puberty). With malnutrition, meeting the high demand for essential nutrients is not possible. If you are thin, you can expect an increased risk of folate deficiency and neural tube defects in the fetus if a woman becomes pregnant.

Lack of bioavailable calcium is another major health problem when underweight is underweight, with all the ensuing consequences for bones and teeth. It becomes difficult and inadequate to achieve skeletal maturity (peak bone mass) by the end of 20 years (5-6). Possibility of pregnancy if underweight increases the risk of preterm delivery of a low birth weight fetus.

Overweight is a risk factor for the development of chronic non-communicable diseases - type 2 diabetes mellitus, arterial hypertension, coronary heart disease, biliary dyskinesia, gonarthrosis (2,3).

It is now known that adipose tissue is not only a storehouse of bodily energy in the form of triglycerides and glycerol. Adipocytes play an important role in the regulation of energy balance by releasing a number of hormones and molecules - adipokines, which significantly affects the hormonal status of a young woman and her reproductive functions.

A comparative analysis of the results of our study with the data of previous national surveys of the anthropometric nutritional status confirms the conclusion that young women in Bukhara region are a population risk group in terms of the anthropometric nutritional status - both for the whole country as a whole and separately for the urban and rural population:

1. Young women are a population risk group in terms of malnutrition (16.8%), overweight and obesity (23.4%), assessed on the basis of BMI;
2. Women living in rural areas have a higher rate of overweight / obesity (27.6%) than their peers in urban areas;
3. Deviations from the normal BMI (underweight, respectively - overweight / obesity) pose a threat to health and reproductive functions.

The results of the study showed that: 59.8% of women of fertile age surveyed have a normal body weight; 18.8% - underweight; 31.4% are overweight and obese. It is concluded that the assessment of anthropometric status justifies the need to develop an educational program to optimize nutrition, which is a key factor for reproductive health.

## CONCLUSION

There is a need for a national strategy to optimize the anthropometric nutritional status of women of fertile age - promoting healthy diets, awareness raising campaigns, introducing good marketing, advertising and food labeling practices (2,4). For it is undeniable that nutritional imbalances are essential for the high social and economic cost that society pays for health problems.

## LITERATURE:

1. Angelova K., Duleva V., Petrova S., Baykova D., Ivanova L., Yancheva M. National study of food intake and nutritional status of the population in Bulgaria, 1997. *Hig. and healthcare*. 2000, XLIII, 1 46-47.
2. Markov P., Vodenicharov E., Duneva Z., Baikova D., Duleva V. Practical guidelines for optimizing the nutrition of women of childbearing age. In: "The science of nutrition in the protection of human health", ed. B. Popov, S., 2004, 218 - 221.
3. KhI Zhuraeva, MA Mazhidova, KhSh Yakhyaeva Analysis of the assessment of attitudes towards the state of their health among the unorganized population *Biology and integrative medicine*, 2018
4. Nuraliev Nekkadam Abdullaevich, Safarov Jakhongir Oripovich, Khasanov Mukhriddin Khayotovich, (2021). Effectiveness Of Domestic Preparation Kromoviz In Treatment Of



- Allergic Conjunctivites. The American Journal of Medical Sciences and Pharmaceutical Research, 3(06), 59-65.
5. Khasanov Mukhriddin Hayatovich. Changes In Corneal Thickness In Patients With Different Stages Of Primary Open-Angle Glaucoma.... ACADEMICIA: An International Multidisciplinary Research Journal 2021.—P. 217-220
  6. KI Juraeva, BK Badridinova, BS Kadirov, MA Majidova, KS Yakhyaeva, Frequency of meeting the main components of the metabolic syndrome during disturbance of different phases of glycemic curve...ACADEMICIA: An International Multidisciplinary Research Journal 9 (1), 80-85
  7. Rizayeva M.A, YahyoyevaH.ShA COMMON SYMPTOM OF ANEMIA IN DIABETIC NEPHROPATHY .... ACADEMICIA: An International Multidisciplinary Research Journal 2021.—P. 1683-1686
  8. Ismailov S.I., Urmanova Yu.M., Nabieva I.F. Assessment of the hypothalamic-pituitary-gonadal axis in men with metabolic syndrome and androdeficiency depending on age (literature review) // International Journal of Endocrinology. - 2012. - No. 1.
  9. Kiessling S.G., McClanahan K.K., Omar H.A. Obesity,hypertension and mental health evaluation in adolescents: a comprehensive approach // Int. J. Adolesc. Med. Health. —2008. — Vol. 20. — P. 5-15.
  10. Kh.Sh Yakhyaeva. Diabetes mellitus type 2 in children and adolescents of the Bukhara region. // Biology and integrative medicine //2021.—P. 139-145.

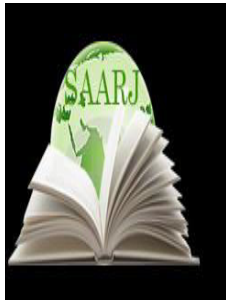

**ACADEMICIA**  
**An International**  
**Multidisciplinary**  
**Research Journal**  
 (Double Blind Refereed & Peer Reviewed Journal)

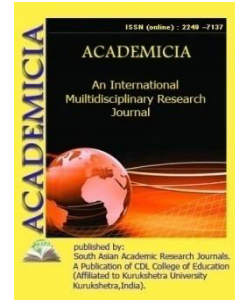

**DOI: 10.5958/2249-7137.2021.01868.1**

## PREVALENCE OF LIPID AND GLYCEMIC COMPONENTS OF METABOLIC SYNDROME IN THE POPULATION OF ELDERLY AND OLD AGE IN BUKHARA

**Gulchekhra Khamraevna Razhabova\***; **Karomat Shoyimovich Dzhumaev\*\***

<sup>1,2</sup>Department of Internal Medicine and Endocrinology,  
 Bukhara State Medical Institute,  
 UZBEKISTAN

### ABSTRACT

*The survey coverage was 1251 (99.7%) and 246 (99.2%) elderly people, respectively, according to the samples. In our studies, these factors were also subjected to epidemiological study and analyzed together with other colleagues, participants in a comprehensive program of population study of CVD in the conditions of Bukhara. Among the population of elderly and senile women, the prevalence of newly diagnosed hyperglycemia was found with a frequency of 16.6% (in women 60-74 years old - 19.5%, in women 75-89 years old - 3.6%  $P < 0.001$ ). In our study, we studied the prevalence of lipid and glycemic components of MS, we found that the highest prevalence of hypo-HDL cholesterol was found in people 60-74 years old - 43.2%, and in elderly people (75-89 years old) - hypo-HDL cholesterol was determined with a frequency of no more than 40.5%.*

**KEYWORDS:** *Respectively, Prevalence, Comprehensive*

### INTRODUCTION

Metabolic syndrome should be considered as a syndrome that develops in response to one or more risk factors for CVD / non-infectious pathologies [Pinkhasov BB, Lutov Yu.V. et al., 2017; Drapkin O.M., 2018; Yurepko A.V., Antonov M.V. et al., 2010; Egamberdieva D.A., 2019].

The development of MS is influenced by such factors as smoking, hypertension, BMI, alcohol consumption (AA), physical inactivity and low consumption of vegetables and fruits (NPF). In our studies, these factors were also subjected to epidemiological study and analyzed together with other colleagues, participants in a comprehensive program of population study of CVD in the conditions of Bukhara.

## Purpose

To study the prevalence of lipid (high-density lipoprotein cholesterol - HDL cholesterol, triglycerides) and glycemic (history of hyperglycemia - HGA, newly diagnosed hyperglycemia HGVV, impaired glucose tolerance - IGT) components of the metabolic syndrome in the elderly and senile population.

## MATERIALS AND RESEARCH METHODS

Two representative samples were formed in the amount of 1503 people: the first among the male and female population 60-74 years old, the second among men and women 75-89 years old. In both samples of the population from the latest electoral lists, including all elderly and senile people living in Bukhara, random proportional 10% samples of 1503 people were organized, amounting to 1255 and 248 people, respectively. The survey coverage was 1251 (99.7%) and 246 (99.2%) elderly people, respectively, according to the samples. Using the methods of phased epidemiological stimulation (Voevoda M.I. et al., 2017), a population study was conducted from January 2017 to December 2019, while only 1497 people were examined, the "response" was 99.6%, and the group " non-participation "- 0.4%.

## Results of the study

The highest prevalence of HDL cholesterol (hypo-HDL cholesterol) was found in people 60-74 years old - 43.2%, and in elderly people (75-89 years old) - hypo-HDL cholesterol was determined with a frequency of no more than 40.5% ( $P < 0.05$ ). In the general population (60-89 years old), it was observed in 33.8% of cases.

In the PZHPWV population, this MS component was detected in 47.7% of cases by 5.0% more in the elderly (49.9%) than in senile (44.9%) people ( $P > 0.05$ ).

The prevalence of hypo-HDL cholesterol in the population of elderly and senile men was 35.7%, was recorded 1.3 times, more often in men 60-74 years old than in men 75-89 years old (45.0 and 35.2%, respectively,  $P < 0.05$ ). GTG was noted in 45.6% of cases.

Thus, HTG and hypo-HDL cholesterol with high detectability were characterized in old age and in women; comparatively lower prevalence was noted among the elderly population.

The study also showed that such components of MS, as the primary detected hyperglycemia (HHvpV), hyperglycemia previously detected (HPA), and impaired glucose tolerance (HTT) in the surveyed population. Bukharawas 13.1% (13.7% in elderly people, 4.1% in elderly people,  $P < 0.001$ ).

It turned out that HHVPV is determined 3.4 times more often in the elderly than in the elderly.

Among the population of elderly and senile women, the prevalence of newly diagnosed hyperglycemia was found with a frequency of 16.6% (in women 60-74 years old - 19.5%, in women 75-89 years old - 3.6%  $P < 0.001$ ). Among representatives of a representative sample of men 60-89 years old in the city, the prevalence of HHVPV was 8.9% (9.8% in men 60-74 years old, 4.6% in women;  $P < 0.01$ ).

Consequently, according to the results obtained, HHVPV was recorded in older women more than 2 times more often than in men ( $P < 0.05$ ).

The data obtained in our study showed that the prevalence of HPA, a component of MS, in the general population 60-89 years old is recorded with a frequency of 11.6% (in the population 60-74 years old - 10.9%, in the population 75-89 years old - 15, 0%;  $P < 0.05$ ). Its detection rate is more than 1.5 times or 4.1% higher in the elderly than in the elderly population. Similar tendencies were observed in the group of surveyed women (PZHPVV) and men (PWPPV) of Bukhara.

Thus, the prevalence of HPA in the general population, a representative sample of women, was 13.5% (for women 60-74 years old - 12.5%, for women 75-89 years old - 13.5%,  $P > 0.05$ ). With age, the prevalence of HHA was 1.3% higher, i.e. there was a statistical insignificant increase in the level of this component of MS in the studied two age groups of women.

In the group of examined PMPP, the prevalence of HHA was 9.3%; statistically insignificant prevalence of this factor was found in men 75-89 years old (11.1%) than in men 60-74 years old (8.9%);  $P > 0.05$ .

In general, it was noted that HPA is determined 1.5 times more often in women (13.5%) than in elderly and senile men (9.3%).

In a representative sample of women and men 60-89 years old in the city of Bukhara, the prevalence of NTG was 13.0% (12.5% in the population 60-74 years old and 15.5% in the population 75-89 years old;  $P > 0.05$ ).

In the surveyed sample of women 60-89 years old, the prevalence of NTG was 13.2% (in women 60-74 years old 11.7% and in women 75-89 years old - 13.4%). With age, its prevalence increased by 1.7%, i.e. there is a significant insignificant increase in the frequency of this MS component in women in the age ranges from 60 to 74 years old and from 75 to 89 years old ( $P > 0.05$ ).

In men, a slightly different epidemiological pattern is observed in terms of an increase in the frequency of detection of NTG in old age. Thus, among representatives of a representative sample of men 60-89 years old in Bukhara, the prevalence of NTG was 12.1% (11.8% among people aged 60-74 years and 17.6%, i.e. with an increase of more than 1, 4 times, in persons in the group 75-89 years old;  $P < 0.05$ ).

In the surveyed population, PZHPPV and PPSPV, impaired glucose tolerance was determined in the following prevalence levels, respectively in the age range 60-89 years - 13.2% and 12.1% each ( $P > 0.05$ ), in 60-74 years - 11.7% and 11.8% ( $P > 0.05$ ) and in the age group of 75-89 years - 13.4% and 17.6% ( $P < 0.05$ ).

## CONCLUSIONS

In general, the analysis of the prevalence of NTG and other components of the metabolic syndrome revealed a greater susceptibility to lipid and glycemetic factors in elderly and senile women.

In our study, we studied the prevalence of lipid and glycemetic components of MS, we found that the highest prevalence of hypo-HDL cholesterol was found in people 60-74 years old - 43.2%, and in elderly people (75-89 years old) - hypo-HDL cholesterol was determined with a frequency of no more than 40.5%. In the general population (60-89 years old), it was observed in 33.8% of

cases. In general, this RF (component of MS) was characterized by high detectability in old age and in women; a relatively lower prevalence was noted among the elderly population.

According to the results obtained, HHVPV in older women was recorded more than 2 times more often than in men. The prevalence of HPA, a component of MS, in the general population 60-89 years old is recorded with a frequency of 11.6% (in the population 60-74 years -10.9%, in the population 75-89 years -15.0%). Its detection rate is more than 1.5 times or 5.9% higher in the elderly than in the elderly population. It was noted that HPA is determined 1.5 times more often in women (13.5%) than in elderly and senile men (9.3%).

In a representative sample of women and men 60-89 years old, the prevalence of NTG was 13.0% (12.5% in the population 60-74 years old and 15.0% in the population aged 75-89 years).

### **BIBLIOGRAPHY**

1. AslonovaSh.Zh. Comparative assessment of the effectiveness of moxonidine and metmorphine in the correction of the components of the metabolic syndrome // abstract of thesis. honey. sciences. -Tashkent. -2011. -C.5.
2. Grishchenko E.B., Shekina M.I., Arkhipova S.S., Shcherbenkov I.M. Self-control of glycemia as one of the important components of the fight against metabolic syndrome // Handbook of an outpatient doctor. -2016. -№5-C.20-25.
3. Kayumov U.K., AslonovaSh.Zh., Alimov S.S. Correction of the main components of the metabolic syndrome using moxonidine and metmorphine // Information letter approved by the Ministry of Health of the Republic of Uzbekistan (11.02.2009, No. 0166).
4. Kalandarova U.A., Ibadova M.U., Ismatova M.N., Kayumov N.U. Dynamics of levels of metabolic syndrome components in different types of hyperglycemia // Journal Biomedicine and Practice.-2019.-№1.- P.77.
5. Metabolic syndrome // Ed. Roitberg G.E. –M.: Publishing house MED-pressinform-2017.



**ACADEMICIA**  
**An International  
 Multidisciplinary  
 Research Journal**  
 (Double Blind Refereed & Peer Reviewed Journal)

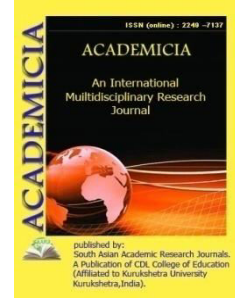

**DOI: 10.5958/2249-7137.2021.01869.3**

## IDENTIFY THE FEATURES OF COMMERCIAL VOCABULARY IN THE CATEGORY OF ADJECTIVES AND TEACH THEM USING MODERN TECHNOLOGY

**Toshpulatov Dilshodjon Abdurafiqovich\***

\*Teacher of "Languages"

Department TUIT Samarkand branch Named after Muhammad al-Khwarizmi,  
 UZBEKISTAN

Email id: dilshodjon2705@gmail.com

### ABSTRACT

*This article provides detailed information on the definition of the properties of commercial terms in the category of adjectives and their number by type, in the form of percentages, as well as artificial adjectives and compound adjectives. Suggestions are also made on how data can be transferred in modern learning. It is no secret that the teaching of commercial terms in foreign languages at universities has become an important issue today. It is well known that the main purpose of teaching commercial terms in a foreign language is to serve the education of a perfect person with deep and sufficient knowledge. Monitoring is an effective technology that determines a person's professional development and self-development. Its results serve as an information base for making management decisions and designing the professional growth and careers of professionals.*

**KEYWORDS:** *Lexical-Grammatical, Adjective, Artificial Adjectives, Primitive Adjectives, Compound Adjectives.*

### 1. INTRODUCTION

In applying these concepts and principles to life, a creative approach is needed to them. They need to be creative, useful, impactful and unconventional at the same time. Non-traditional teaching methods in teaching commercial terms in English are done after a specific topic or several topics. It is very important to have control in such a teaching method. Such classes take place in an unconventional environment that students do not expect. It would definitely be purposeful to conduct the lessons in this way. The reason is that in such an environment a festive



mood is created, the barrier between the teacher and the student or pupil is removed, that is, the feeling of fear that arises from making mistakes in students is put to an end.

Intergroup refers to the presence of units of different lexical grammatical word groups to express this or that concept. (Buranov, 1983)<sup>1</sup>

Our observations show that different lexical-grammatical groups of words with statistically incorrect indicators are involved in the expression of this commercial lexicon. For example, 52.5% of the total number of units of commercial lexicon selected by us are words belonging to the category of nouns, the rest are 11.7% of adjectives and 35.6% of verbs.

Lexical-grammatical categories of words	root words	artificial words	compound words	total
	number %	number %	number %	number %
nouns	183 48	176 56,9	29 54,7	388 52,2
Adjectives	33 8,6	44 14,2	10 18,9	87 11,7
Verbs	165 43,3	89 28,8	14, 26,4	286 36,1
Total:	381 100	309 100	53 100	743 100

Thus, the analysis of language material led to the following conclusion: not only words belonging to the noun phrase, but also adjective and verb phrases are involved in expressing commercial lexicon in English. These words, in turn, are divided into primitive, artificial, and compound words according to their structure, and the statistical indicators of each word structure are different from the others.

## II. Experimental methods

### *Adjective*

Among word groups, adjective, as we know, refers to the sign of an object. Accordingly, they are also widely used in commerce. But they are second only to nouns and verbs in number and make up 11.7% of the total.

The adjectives included in the words that express commercial lexicon in English are also divided into three types according to their construction.

- 1) Primitive adjectives;
- 2) Artificial adjectives;
- 3) Joint adjectives.

Artificial adjectives are widely used in the expression of commercial lexicon of these types of adjectives, so we will consider them in the first place.

## III. Development of oral speech skills.

### *A) Analysis of artificial qualities*

The adjective phrase belongs to a large group of words in English. About 8,600 of the 60,000 words in Professor Mueller's<sup>2</sup> Anglo-Russian Dictionary belong to adjectives. Of these, 1,200 are original words and the remaining 7,400 are artificial words.

The number of suffixes in artificial adjectives is 65, and the number of prefixes is 171. However, not all of them are word-forming elements of adjectives. In English, the suffixes "relative" and "original relative" are derived from other word categories, and the original artificial adjectives are derived from the adjectives themselves.

Suffixes are a sign that words belong to a grammatical class of adjectives. Some suffixes in English also serve for semantic differentiation in a given grammatical class.

*1) –able (-ible) suffix*

The suffix -able (-ible) came into English from the Latin word and is widely used as a word-forming element. The -able (-ible) suffix is made up not only of Roman stems, which are characteristic of most Romance language suffixes, but also of German stems and stems of other origins.

In English, as in Latin, the suffix -able began to form an adjective from the root of the verb, meaning "prone to do something." The -able suffix usually means passive. The given characteristic of this suffix is also observed among a number of artificial adjectives belonging to the commercial lexicon. For example:

Adjustable - flexible

Advisable - recommended, expedient, acceptable

Appreciable - measurable, tangible, visible

Assessable

In addition, adjectives with the suffix -able (-ible) also had causal connotations and the like (they are made up of verb and noun stems). For example:

Admissible - acceptable, acceptable

Agreeable - pleasant, appropriate, noticeable

Applicable - applicable, compatible

Available, cash

The qualities being analyzed are very common and productive in their first sense.

As for words made with -able, in modern English this suffix rises to such a level of productivity that even when used, the researchers we wanted did not make any adjectives because they did not accept the use of the -able suffix as a word-forming element in English.

In the history of its existence in English, the -able has only served as a sign of quality as a phrase.

*1) –al (-aical) suffix*

Adjectives with the suffix -al (-aical) are formed from the stems of nouns and mean "relationship". For example: actual - real, original, modern, actual - annual - annual, annual - al suffix adjectives are widely used in English.

*1) - ate suffix*

- The suffix ate has many meanings, and the noun forms an adjective from the root of the word. -  
The suffix ate has the following meanings:

- 1) 1. A characteristic, essentially known possessive of something. For example:
- 2) associate - connected to each other
- 3) 2. The meaning characterized by the existence of what the core expresses. For example:  
alternate - in turn - alternately, in reserve.

4) *-ary (-ory) suffix*

Adjectives with the suffix -ary (-ory) mean "belonging to something, related to something". Subjective adjectives are formed from the stems of horses (sometimes verbs). These characteristic features of -ary (-ory) suffixes are also reflected in the commercial lexicon. For example:

- 4) Advisory - a consultant, a board
- 5) Auxiliary - with the help of additional, secondary, reserve
- 6) Adjectives with the suffix -ary (-ory) are common in English and are not productive.

8) *-ed suffix*

Genetically, this suffix (Old English -od, -ad suffixes) is a form-forming suffix, forming a past tense and adjective II from weak verbs. In the process of the development of the English language, these adjectives were used as descriptive functions and adopted the feature of adjectives. Later, words with such adjectives began to be formed from the root of the horse, ending in -ed, but gradually began to accept the function of making such words. In modern English, the suffix -ed verb and the -ed suffix of adjectives are considered as antonyms.

The -ed suffix is the most productive of all adjective suffixes. It only attaches to the core of the horses. Some English scholars, such as E.M. In English, there are indeed adjectives ending in the verb -ed suffix, and some adjectives in the commercial lexicon, but all of them are adjective IIs with the suffix -ed. For example, we compare several adjectives and adjectives:

Adjusted - corrected, adapted

Appreciated - in accordance with the value

Assumed - imaginative, permissible, predictable

Attested - certified, testified

Automated - automated, automatic

It is known from these examples that in adjectives -ed only play the role of word-formers in adjectives formed from horses.

9) *-ic suffix*

Adjectives with the suffix -ic are formed from the stems of horses and have the meaning of "relationship". For example: authentic - real, original

9) *-ive suffix*

Adjectives with the -ive suffix are formed from the stem of the verb and mean "relationship": For example

- 7) Administrative - manager, lessee
- 8) Alternative - alternating, mutually exclusive
- 9) Attractive - attractive
- 10) Authoritative - authoritative, trustworthy, and dominant, command-type English - and suffix adjectives are less productive.
- 10) -ous suffix

The suffix came into English with Latin words ending in -ous (-us). As a result, the English language took the form -ous when a large number of old French words ending in -ous flowed into it. This suffix can be found not only in Roman, but also in Germanic, Greek, and other stems.<sup>3</sup> For example:

Captious (L-captosus) - capricious, baseless accuser

Carious (L.-cariosus) - rotten

Barglarious (O.G'.- borg) - belonging to the thieves, thieves

Dangerous (O.G'.-dangier) –hafli

Harmonious (Cr.-harmonia) - mutually compatible

Mysterious (Gr –mysterion) - mysterious

Wonderous (A.S. -wunder) - weird, weird, weird

Murderous (A.S. -morthor) - deadly, bloody, deadly

In Latin and Old French, the suffix -ous is derived from the root of a horse. He also retained this feature in English. It should be noted that when separating the -ous suffix from a word, we do not always have a root word that means something. However, in words formed on the basis of the English language, the stem used as a noun phrase in the language is clearly distinguished.<sup>4</sup>

When the adjective -ous suffix was used to form an adjective from the nouns of the commercial lexicon, it was said that the suffix should give them a meaning, a sign, a quality, which is expressed by the word-forming nucleus. For example:

Autonomous is autonomous, self-governing.

In English, the -ous suffix is not widely used as a suffix-forming element, because in English the suffix -phil, which has this meaning, already existed. Like the -ous suffix, it is created and continues to be used as an abstract noun for living things, a characteristic of objects. For example:

Beautiful (beauty) - having the qualities that constitute beauty (Compare: in French beate - beauteous –full of beauty)

Graceful (grace - from the word) –characterized by grace (Compare: gracious - “full of kindness or love”). The word is derived from the French word grace nazokat latofat. Thus, in conclusion,

it is a living suffix of the English language, although it is no longer used in quality making, due to competition with a similar productive-phil suffix.

### C) Root adjective

Like all other words, primitive adjectives are among the words used in the field of commerce, but their number is very small. However, the basic adjectives are divided into two groups according to their commercial use: A) words that directly (explicitly) represent the commercial vocabulary: Free - free, free, free from the accumulation of costs for delivery of goods to the destination, Fiscal - financial, fiscal Cheap - cheap, low purchase price (about currency), Private - private, Stock - share, Gross - wholesale, Premium - first grade, high quality.

V) words that implicitly (implicitly) represent the commercial vocabulary: Heavy - motionless (about the market), heavy, Mean - average (price, exchange rate), Weak - declining (about prices), weak, Net - pure (profit, weight) , balance, general, Strong - rising (about prices), independent, strong, Slack - weak (about trade, market)

### C) Compound adjectives

This type of adjective is the least numerous among the words belonging to commercial terminology, as the lexicon set aside for analysis has clearly shown this.

Accordingly, such qualities constitute the following models. Adj + N Most of the compound adjectives are represented by this module. The second component of the model is the keyword, and its first component serves as a determinant of that word.

For example: Short-term - short-term, Extra - high quality, High - grade - high grade, High - duty - product, Pref + P2, Semi - finished, Semi - manufactured semi-finished, Semi - processed, Adj + P2 , Short -dated – So compound adjectives are basically divided into two compound words. In conclusion, in order to introduce this unique device to the student, it is necessary to introduce new teaching technologies and create conditions for mentoring on it.<sup>5</sup> [7]

## V. CONCLUSION AND RECOMMENDATION

Based on the above examples, it should be noted that today the youth of the Republic have the opportunity to achieve their goals and increase their competence, which, unfortunately, can be seen in the monitoring or analysis of such populations. At this point, of course, we believe that an educator who considers himself a modern teacher should be constantly researching himself.

## LIST OF REFERENCES

1. Kubryakova EG .. On the mental lexicon: lexicon as a component of a person's linguistic ability. Actual problems of modern linguistics. Publisher: Flint M.2007; p. 327.
2. Big linguistic encyclopedic dictionary. Compiled by V.N. Yartseva, 1990
3. Muller "English-Russian Dictionary" 1956. 43p.
4. Buranov J.B. Typological categories and comparative study of languages: Author's abstract. Diss. ... doc. In philological sciences. –M., 1979. -48s
5. Barkhudarov L.S. The structure of a simple sentence in modern English. –M .: higher school, 1966.-384s

6. Balli S. French stylistics. –M.: Ed. Foreign Literature, 1961.-394s
7. Toshpulatov D.A. Training and monitoring analysis of commercial lexemes in English using traditional learning// Psychology and Education //Spanish -2021 Scopus/ Philosophical readings XIII 4(2021), pp16-21 10/5281 /zenodo/4730452



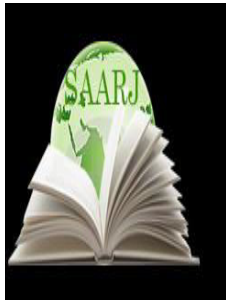

**ACADEMICIA**  
**An International  
 Multidisciplinary  
 Research Journal**  
 (Double Blind Refereed & Peer Reviewed Journal)

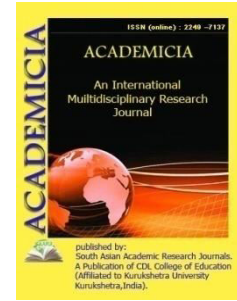

**DOI: 10.5958/2249-7137.2021.01870.X**

## ON THE SEMANTICS OF SOME WINGED WORDS IN THE FRENCH LANGUAGE

**Isakova Guzalkhon Nematovna\***

\*Docent, Doctor of philosophy,  
 European Medical University,  
 UZBEKISTAN

Email id: isakova-guzal@mail.ru

### ABSTRACT

*Winged words occupy a special place in national and world culture, reflecting the thoughts of great philosophers, scientists, writers and statesmen in a polished form. These are phrases that clearly and figuratively convey deep thoughts in a laconic form, briefly outline the meaning of complex situations and characters. The following article gives an idea of the winged phrases that characterize the negative traits that are observed in male and female relationships. Their meaning is widely covered through semas, where the meaning of the words is clearly described.*

**KEYWORDS:** *Winged Word, Phrase, Figurative, Meaningful, Laconic, Sema, Negative, Feature, Meaning.*

### INTRODUCTION

Winged words have a special place in national and world culture; they are the polished thoughts of famous philosophers, scientists, writers and statesmen. Winged words are special phrases used as figurative quotations in speech. They are widely used in the speeches of people who speak different languages. Winged words are distinguished by their aphoristicism, comprehensiveness, meaningfulness, applicability and possession of a clear source. They are phrases that express figurative meaning in a clear and complex situation and characters in a concise form of deep thoughts in speech.

### Analyses of appropriate literature

Although much researches have been done on winged words, their semantic aspects have not been fully elucidated. From the earliest period of the study of winged words, more attention has been paid to the question of identifying their sources, their authors. In the first works devoted to the semantic problems of winged words the problems of illumination of the figurative meanings

of winged expressions and the definition of certain semantic features in them are observed (M.I.Mixelson, S.V.Maksimov) [2].

Linguist S.G.Zaymovsky emphasizes that the essence of winged words is “always a reminder of irony, a great idea, a moment, a situation”, and writes in the introduction of his manual: “Although it is not important from academic point of view, it is of practical importance, in our opinion, it is important to know the original source, the moment and the situation in which the phrase came into being, not in itself, but often in order to understand the quotation correctly” [5].

V.P.Berkov also expressed his views on the semantics of winged words. He divides winged words into 2 groups based on the nature of the meaning being expressed. The author includes units that retain their original meanings into the first group and units that changed their original meanings into the second group. The author explains that “winged words allow a person to express their thoughts briefly and vividly, they can convey deep meaningful thoughts that are difficult or even impossible to achieve with other words, they express deep philosophical truths of an aphoristic nature”[4].

In the semantic description of winged phrases, many researchers are limited to describing their figurativeness, aphoristicism, depth of expressed thoughts and conciseness, while many other researchers believe that an important feature of the meaning of winged expressions is that it has a “genetic memory” about the source (Yu.N.Afonkin, N.T.Babichev, A.M.Jigulev, T.G.Kazachenok, A.P.Koval, S.G. Shulejkova).

### **Methodology of research**

Much work has been done in recent years on the study of winged words on their semantic properties. For example, S.G.Shulejkova, taking into account the relationship between the original meaning of the components of winged words and its meaning in the form of a compound, distinguishes 2 types: 1) winged phrases with transparent analytical semantics derived from the meanings of components; 2) winged phrases that undergo various migrations in the semantic and emotional-expressive plan [3]. In the first type, the author meant winged words used in their original sense, while in the second type, he meant winged phrases used in a figurative sense.

It's known that no matter what type of winged phrase belongs to, no matter what it means, it is characterized by semantic stability. The permanent meaning is understood from the combination of its components and the winged expression is interconnected with an object, event, relation, sign, process or state. Characters belonging to winged expressions as a constant, stable unit of meaning, the perceptibility and stability of component composition and grammatical structure characterize all winged expressions equally.

Accordingly, we aimed to categorize the semantics of winged words in a unique way, that is, on the basis of analysis, depending on the content and essence of the semas understood from them.

### **Analyses and results**

The following is a discussion of the winged phrases used in French to describe the negative traits observed in male-female relationships. Based on the analysis, various semaphores are identified from their content.

First of all, let's have a look at the negative winged expressions that apply in this category to men.

For example, the phrase *Etre amoureux des onze mille vierges* (fr.), inherited from ancient myths, which refers to *falling in love with eleven thousand virgins*, is used by the French to flatter men who do not tire women. In men who cannot control such feelings intelligently, the traits of weakness, lightness and betrayal are predominant. The meaning of the phrase is "instability", "lightness", "liquidity", "disorder", "betrayal".

*Don Juan* (fr.). The main hero of Moler's satirical comedy "Don Juan" is portrayed as an aristocratic young man of his time, and all his shortcomings are exposed throughout the work. The protagonist, Don Juan, is a man who is ready to marry any woman, expresses love to all women or girls, he lives an unstable and absurd life and leaves his wife after every step of marriage. Accordingly, the name *Don Juan* is still used today to refer to those who are adept at seducing girls and women, and who love romantic adventures. This winged word means "instability", "femininity", "deceit".

*Cherchez la femme!* (fr.) was first mentioned in the diary of James Gollatin, an American who lived in France in 1816-1827. This was in connection with Berisky's death, when Gollatin used the phrase "Search for a Woman" to mean "a woman was involved in this crime." However, the popularity of the expression is associated with the work of A.Duma (father) "Les Mohicans de Paris" (1854). The phrase is repeated many times in the play, and it was a favorite expression of one of the characters, a police officer. She believes that almost half of all crimes occur through men's treatment of women, and that women are at the center of crime. Nowadays, the phrase is used figuratively to refer to "a man who never tires of flattering women". The phrase can be understood as "instability", "flattery", "frivolity", "immorality".

*Alphonse* (fr.) The protagonist of A. Duma's (son) poem "Monsieur Alphonse" (1873). Alphonse is a man who owns property, makes rich women fall in love with him and then lives at their expense. Due to his character, the word Alphonse means a person who makes a living at the expense of his lovers. It has the semantics of "disgrace", "arrogance", "impurity" and "cunning".

The winged word *Barbe Bleu* (fr.), which belongs to C.Perro, famous for his fairy tales of goodness, is taken from his fairy tale "La Barbe Bleu" (1697), which is included in his collection "Les Contes de ma mèrel'Oye". The tale is about a blue-bearded, murderous, cruel landlord who kills his six wives. Only his seventh wife is saved with the help of his brothers. Accordingly, the phrase Blue Beard has become synonymous with "jealous", "cruel", "brutal", "selfish".

Among the winged words, negative expressions applied to women are also observed. There are some examples of winged phrases such as *Femme de Loth* (fr.), *Dalila* (fr.), *Dame aux Camélias* (fr.).

*Femme de Loth* (fr.). (Latin: *Uxoris Loth*). According to biblical legend, when God burned the cities of Sodom and Gomorrah for their immoral habits, the lonely Lot family, who were hostile to the angels, was given the right to leave the city on condition that they never return to the city. Lot's wife abuses this prohibition without heeding her husband's explanation and turns it into a statue made of salt. Accordingly, Lot's wife's phrase is applied to "a woman punished for her curiosity" and it contains the semantics of "disobedience" and "ignorance".

*Dalila* (Latin, fr.) *Dalila* is one of the characters in the Bible, the wife of Samson. *Dalila* realizes that Samson's supernatural power is in his hair, so she cuts his hair while he sleeps and betrays own husband by handing him over to her countrymen. As a result, *Dalila's* name became a symbol of "traitor".

The protagonist of *Dame aux Camélias* (fr.) from A.Duma's (son) "La Dame aux Camélias" (1848), was a light-hearted woman who loved the camellia flower. Due to the character of the protagonist, the French use the term Camellian woman to mean "light-hearted woman". The meaning of the phrase is "frivolity", "flippancy", "disorder", "amorality".

### CONCLUSION

Based on the results of the analysis, it can be said that winged words express the negative features observed in male-female relationships in a figurative, concise, succinct, meaningful way and thus in relation to an event or phenomenon. From the content of the above examples, the specific meanings of such words as *femininity*, *instability*, *frivolity*, *lightness*, *laziness*, *depravity*, *betrayal*, *deceit*, *arrogance*, *impurity*, *deceit*, *jealousy*, *oppression*, *butchery*, *selfishness*, *disobedience*, *ignorance* allows them to be selected for appropriate use.

### REFERENCES:

1. Le Petit Larousse illustré. Dictionnaire encyclopédique. – Paris, 1993.
2. Mihel'son M.I. Metkie i hodyachie slova. Sbornik russkih i inostrannyh poslovic, izrechenij i vyrazhenij. SPb, 1894.; Maksimov S.V. Krylatye slova. – Moskva: Izd-vo hudozh. lit., 1955.
3. Shulezhkova S.G. Krylatye vyrazheniya russkogo yazyka, ih istochniki i razvitie. –Moskva: Azbukovnik, 2002. -Str.211.
4. Uolsh I.A., Berkov V.P. Russko-anglijskij slovar' krylatyh slov. – Moskva: Russkij yazyk, 1984. -Str.6.
5. Zajmovskij S.G. Krylatye slova. Spravochnik citaty i aforizma. –Moskva; Leningrad: Gosizdat, 1930. -Str.15-16.



**ACADEMICIA**  
**An International**  
**Multidisciplinary**  
**Research Journal**  
 (Double Blind Refereed & Peer Reviewed Journal)

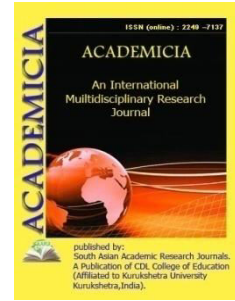

**DOI: 10.5958/2249-7137.2021.01871.1**

## TURKIC CLASSIC POETRY: TRANSLATION PROBLEMS

**O. Dadaboyev\***

\*PhD

Namangan state university,  
 UZBEKISTAN

### ABSTRACT

*The article analyzes the problems of translating XV century Turkic poetry into English. During the discussion, various ways of translating ghazals into English were discussed. Each word in the poem depends on all the meanings of the words adjacent to it and is determined by the numerous characteristics of the whole text, and the meanings and words themselves are multilayered and reflect the spiritual search of the author. In addition, poems have a special tempo, a special “musicality” of words, which is often extremely difficult to reproduce in the target language without a more or less significant distortion of meaning.*

**KEYWORDS:** *Ghazal, Translation, Translation Problems, Translation Ways, Prose Translation, Poetic Translation, Adequate Translation.*

### INTRODUCTION

In order to translate literary works, especially poetry, one must also reach the level of art in the field of translation. However, translation is a complex, individually and situationally unique activity. Translation difficulties are especially well illustrated in the process of translations of poems. Each word in the poem depends on all the meanings of the words adjacent to it and is determined by the numerous characteristics of the whole text, and the meanings and words themselves are multilayered and reflect the spiritual search of the author. To translate a poem, you need to make a whole, multi-stage complex of comparisons of internal and external, obvious and hidden, ethnically specific and general meanings and contexts of writing a poem and its translations. As N.A. Fateyeva notes “The difficult and at the same time creative task of the poetry translator is to decode the compression of the source language material, extract concentrated explicit and implicit meanings from it, and further present them in the compression of the new language and cultural code so that the poem sounds like the original” [2, p. 57].

Poetic translation is one of the most difficult activities. There are several problems with translating poetry: poetry often has several levels of meaning, and often behind an obvious upper layer, which at first glance may seem prosaic or unsophisticated, in the process of discussion it opens up with more and more rich hidden “lower” layers, often not even having a single common semantic interpretation. In addition, poems have a special tempo, a special “musicality” of words, which is often extremely difficult to reproduce in the target language without a more or less significant distortion of meaning. In addition, verses are usually very carefully structured, with specific pieces of information and phrases that are also difficult to reproduce verbatim and accurately. Many translators find it almost impossible to translate poetry.

In this article, we set ourselves the task of giving some key to the quality translation of ghazals of Alisher Navoi, with the help of which translators can overcome some difficulties in the field. Our next goal is to analyze the different types of this special area of the translation craft, requiring a creative approach and a spark literary talent. In addition, we set ourselves the task of making recommendations on the appropriateness of using types of translation in certain cases.

Attempts have taken place these days to translate Navoi’s ghazals into English. Until recently, it was believed that works written in the Aruz meter sound strange to an English-speaking reader. However, the recent growing trend of Western poets writing ghazals opens up new possibilities in this area.

We suggest two ways of translating ghazals. The first one is the prose translation of poetry. Prose translation of Navoi’s ghazals is the simplest approach to translating his poetic works. It is characterized by the fact that the output is a prosaic text that conveys as close as possible to the original semantic, informational and aesthetic components of it.

The objective of this approach is to maximize the disclosure of the idea of the original text, following all the intricacies of the author’s thoughts and transmitting all literary devices, except poetic ones. In this case, one of the most valuable components of the source is sacrificed - the poetic form of the work.

A characteristic difference of this type is that the text resulting from the output is completely devoid of such characteristic elements of the poetic text as rhyme, rhythmic structure and stanza breakdown.

Let’s consider one of Navoi’s ghazal taken from his diwan “Khazoyinul-maoniy” (Treasures of thoughts) and its prose translation:

*Nasihati ulul tezrak bo‘lur ishqim,  
Bale, itikrak etar o‘tni ulki dam qildi.  
Firoq sharhini har kirpigim yozar, go‘yo  
Falak mijamni tengiz ichragi qalam qildi.  
Ul oy azimat etib yuz g‘am-u balo naqdin  
Nasibim etti, yomon bormadi, karam qildi.  
Sipehr ishqda Majnung‘a yozdi ko‘p ta‘rif,  
Muqobilida zamona meni raqam qildi.*



*Ko 'zumki qon aro bo 'ldi nihon ajab ermas,  
 Ki «ayn»g 'a chu dam o 'ldi qarin, adam qildi.  
 Shukufa siym chiqarg 'ach bu gulshan ichra xazon,  
 H'avog 'a bargini sochmoq bila sitam qildi.  
 Navoiy jismin o 'qung zaxmi etti domi balo,  
 Visol qushlari andin magarki ram qildi. [1, 616]*

Prose translation of the ghazal:

*That moon(like Beauty) who made this world dear with her mercy  
 Why looks at me less who is mad in her love?  
 Though the heaven made me crooked in her love  
 To the god thanks for it made me near to her trace.  
 If people around advice me not to love her, my love will be more stronger,  
 Of course, the blow makes fire stronger.  
 My eyelashes write explanation of distress, as if  
 Heaven made my eyelashes pen in the sea.  
 That moon(like beauty) wished me hundreds misfortune and torment,  
 She did not bad by this, she kindly disposed to me.  
 The fate wrote much praise to Majnun on the way of love,  
 As in alternative to him this epoch created me.  
 No wonder that my eye disappeared in the blood,*

*Like if you add the word "dam" (blood) to the letter "ayn" (eye) you will get the word "adam" (which means disappear).*

*The flowers in this garden blossomed in white,  
 And the defoliation caused them suffer throwing their leaves in atmosphere.  
 Your shaft's wound made Navoi's body trap of misfortune  
 That's why the birds of rendezvous fled away from it in fear.*

When is the prose translation of verses unacceptable? You can't translate prose verses whose main value lies in their poetic identity: that is, when the semantic content of poems loses its charm if they are stated in prose. But it should be noted that in poetic form such poetic works are also quite difficult to translate: one must have poetic talent, no less than the talent possessed by the author.

The next way is poetic translation. This type of translation can be divided into two subgroups: free poetic translation where translation has all the properties of a poetic text, except for rhyme. In other words, the translation is in the form of a white verse; adequate poetic translation where

translation corresponds to the original in meaning, form and its artistic properties, in which all the elements characteristic of the poetic work, including rhyme, are used.

It should be noted that the white verse is quite peculiar and often in terms of its poetic properties can even surpass a fully rhymed poetic text, if by poetic properties here we mean the elevation and beauty of the work.

No one will probably argue that translating in this form is much easier than in full poetic form. However, despite the fact that rhyme is not used in this case, it is necessary to observe the poetic size. In this regard, this type of translation, of course, requires the translator to have certain versification skills and knowledge of the types of verse sizes. In the way of the white verse above given ghazal can be translated in the following form:

*That moon who made this world dear with mercy  
Why looks at me less who is mad in her love?  
Though the heaven in her love made me crooked,  
To the god thanks for it made me to her trace near.  
If people advice not to love her, my love stronger will be,  
Like the blow makes stronger fire.  
My eyelashes write explanation of distress, as if  
Heaven made my eyelashes pen in the sea.  
That moon wished me hundreds misfortune and torment,  
She did not bad, she kindly disposed to me.  
The fate wrote much praise to Majnun on the way of love,  
This epoch as in alternative to him created me.  
My eye disappeared in blood, like if the word "dam"  
Added to the letter "ayn" and then you got the word "adam".  
In the garden flowers were in white blossom,  
And the wind made them fade in atmosphere.  
Your shaft's wound made Navoi's body trap of misfortune  
That's why from it birds of rendezvous fled away in fear.*

The use of white verse gives the translator greater scope for creativity, due to the fact that it is not limited to the selection of rhymes.

As we mentioned before by adequate poetic translation we mean the creation of a poetic text corresponding to the original in meaning, form and its artistic properties, in which all the elements characteristic of the poetic work, including rhyme, are used.

*That moon with mercy this world made dear,  
Why at me nor looked, neither came near?*

*Though the heaven in her love made me crooked,  
 To the god thanks for made me to her shade near.  
 Public's advice not to love made me more adore,  
 Like the blow stronger made fire.  
 My eyelashes write explanation of distress, as if  
 Heaven made my eyelashes pen in the lake – mere.  
 That moon wished me dozens misfortune and torment,  
 It was not bad, thus she to me gave care.  
 The fate wrote much praise to Majnun on the way of love,  
 This epoch as in alternative gave me appear.  
 My eye disappeared when blood in it appeared,  
 Like you added “diss” to “appear” and made “disappear”.  
 In the garden when flowers were in white blossom,  
 The wind made them fade in atmosphere.  
 Your shaft's wound made Navoi's body trap of misfortune  
 From it birds of rendezvous fled away in fear.<sup>1</sup>*

A poetic translation is the pinnacle of a literary translation of the text, as it requires the translator not only literary talent and the ability to write poetry, but also the ability to put the original meaning, idea, and even literary devices into the poetic form of another language.

The disadvantages of this type of translation activity include its complexity, laboriousness and high requirements for the skill of the translator.

One of the main problem with this type of translation of poems is the structure of the poetic text, which requires the use of rhymes and a certain poetic size. It is the poetic structure that causes so many difficulties in creating in another language an adequate text to the original. The fact is that the language of translation can significantly differ from the source language, both in style and in linguistic constructions, which sets the task of the translator to melt the author's ideas and images into the form of the final language.

The disadvantage of the poetic adequate translation is that not all language constructions can be given in translation. In the classic literature poets used the art of “istikhroj” that causes difficulties in the translation process. The art of “istikhroj” occupies a special place among the artistic means. The lexical meaning of this art is to “dig out,” that is, to extract words from the letters mentioned in the text.

In above given ghazal Navoi used the art of “istikhroj”:

*Ko 'zumki qon aro bo 'ldi nihon ajab ermas,  
 Ki «ayn»g 'a chu dam o 'ldi qarin, adam qildi.*

Prose translation: No wonder that my eye disappeared in the blood, like if you add the word “dam” (blood) to the letter “ayn” (eye) you will get the word “adam” (which means disappear).

When the tears rolling out of the eyes turn into blood, it is natural that these eyes lose their eyesight. That’s why these eyes will be lost in the blood (qon aro nihon). To depict it the author used one natural resemblance. If you add a letter “ayn”<sup>2</sup> to the word “dam”<sup>3</sup>, you will get a new word – “adam”<sup>4</sup>. The sense of the poetic art “istikhroj” is based on the view of the Arabian letters, their forming new meaning when they are added to other letters or words. Here we can see this linguistic phenomenon. The word “dam” has several meanings. In the dictionaries you can see that this word has the following meanings: breath; sound, voice; grief, sorrow; inspiration; dry wind; wind; just now, very soon; red wine. In the above given dictionary we have given only one meaning that it has in this gazal. According to the context it has the meaning “blood”. As for the “ayn”, it is a letter in Arabian ABC that stands for the vowels “a” and “i”. At the same time this letter has the following dictionary meaning: eye, pupil, spring, mark, and mirror; origin, source, reason, essence, side. Using the play on words the poet wants to say that if the word “dam” come close to the letter “ayn”, there appears a new word – “adam” out of them. The meaning of “adam” is “disappear”. It is obvious here that when blood fill in the eye, it loses its eyesight.

In this place no translator could give the meaning of the couplet as the art of *istikhroj* is based on the play on words *ayn*, *dam* and *adam*. In the translation these words get quite different views that translator can easily destroy the play on words.

When a translator undertakes to translate verses, he first of all needs to decide on one thing: whether the poetic size and structure of the rhyme matches the original or not. The first case is the most difficult, but also the best. If the translator decides to change the structure of the poem, then he/she needs to decide which structure is better to prefer, while the semantic content of the poem must be taken into account: the external form of the work must be appropriate for its meaning.

We may conclude that all types of translation of poems, which we talked about above, have some limitations and conditions for their use. Therefore in translating Navoi’s ghazals it would be better to give both forms of translations: the prose translation and the poetic one that can supply each other to give the author’s idea, language arsenals of the poet and of course the beauty of the language.

#### REFERENCES:

1. Navoi Alisher. “Khazoyinul-maoniy” (Treasures of thoughts). Tashkent: “Fan” publishing house, 1988.
2. Fateyeva N.A. Postperevodcheskiy analiz i posletekstovyy kommentariy v perevode poezii (Post-translation analysis and post-text commentary in translation of poetry)// Inostranniye yazyki v vysshey shkole. 2016. № 2 (37). p. 57–63.

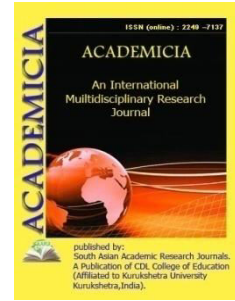

DOI: **10.5958/2249-7137.2021.01872.3**

**PECULIARITIES OF MORPHOMETRIC CHARACTERISTICS OF  
PHYSICAL DEVELOPMENT OF ELDERLY AND OLD AGE PERSONS  
(REVIEW)**

**Shukhrat Zhumaevich Teshayev\***; **Karomat Shoyimovich Dzhumaev\*\***;  
**Gulchekhra Khamraevna Razhabova\*\*\***

\*Department of Clinical Anatomy (OSTA) and Forensic Medicine,  
Bukhara State Medical Institute,  
UZBEKISTAN

\*\*Department of Internal Medicine and Endocrinology,  
Bukhara State Medical Institute,  
UZBEKISTAN

**ABSTRACT**

*Most of the health problems faced by older people are associated with chronic conditions, especially noncommunicable diseases. While most older people will have numerous health problems over time, getting older does not mean addiction. Many of them are preventable or may occur later as a result of a healthy lifestyle. Other health problems can be effectively dealt with if they are identified early enough. And even for people with reduced vitality, a supportive environment can ensure a decent life and continued personal growth. However, the world is still very far from this ideal. Therefore, the problem of population aging requires a comprehensive response from health systems.*

**KEYWORDS:** *Physical Development, Physical Inactivity, Bad Habits, Old And Senile Age.*

**INTRODUCTION**

Physical development, along with such indicators as fertility, morbidity and mortality, is one of the indicators of the level of health of the population, the assessment of which is based on comprehensive studies of morphological and functional parameters of the organism [16; p. 288, 7; p. 54-65]. The level of physical development in different periods of ontogenesis reflects the general patterns of growth and development, but at the same time significantly depends on

social, economic, sanitary and hygienic and other conditions, the influence of which is largely determined by the age of a person.

One of the objective indicators of assessing the health of an organism is the level of its physical development, which reflects the general level of sanitary-hygienic and socio-economic conditions of life of various groups of the population and is subject to changes under the influence of a large variety of external and internal factors [9; p. 191, 11; p. 247.5; p. 50, 18; pp. 30-35, 19; pp. 40-45, 20; p.245].

Currently, there is a tendency towards the aging of the world's population, which is reflected in short- and long-term forecasts of an increase in the duration of active life for people aged 60 and over, and in the age group over 80. According to experts' forecasts, the overwhelming majority of the elderly will be women [2; pp.57-60].

Demographers call an aging population an increase in the relative proportion of older people. The population of a country is considered aged or aging when this proportion exceeds 7-8% of its total population. In Russia, 1/5 of the population (according to 1999 data) are elderly people [17; p.200.1; p. 229].

According to the World Health Organization (WHO), the following age periodization and characteristics of individual development of a person have been adopted: age from 60 to 74 years old is considered as elderly, 75 years and older - senile, age 90 and older - long-livers [6; pp. 133-161]. However, such a distinction into periods is conditional, since the calendar and biological, as well as psychological age do not always coincide. Aging is a hereditarily programmed process accompanied by age-related changes that naturally occur in the body. Physiological old age is the old age of practically healthy people, it is not complicated by any pathological processes [21; p. 396, 22; p. 346].

Obviously, in social terms, the main problem of older people in modern society is to provide conditions for their active lifestyle, while the solution to this problem has both social and economic significance [3; p. 44, 4; p. 23-27].

Physical status makes a significant contribution to the structure of health at all periods of the human ontogenetic cycle. At the stage of growth and development, the formation of physical qualities lays down reserves of well-being for the future and is associated with the formation and functioning of all systems of a young organism. For an adult, physical status is a powerful criterion for working capacity, stress resistance, and adaptive abilities. Deviations of certain parameters of physical development from the population norm can become a serious obstacle in professional selection even in the absence of serious diseases. In old and old age, good physical performance is an important factor in functional independence [13; p. 172, 15; p. 129].

Physical status is a dynamic concept. Changes in morphological and functional characteristics during life depend on many reasons, are determined by a number of regularities and obey the laws of age grading, heredity, unity of the organism and the environment [14; p. 19]. One way or another, it is possible to successfully manage the physical qualities of a person for the benefit of health only if the alleged patterns are proven.

The scientific literature on physical culture presents a wide range of developments on the use of means and methods of maintaining physical activity in older people [8; p. 128-135, 15; p. 129, 22; p.346].



Obviously, for their effective implementation, it is necessary to take into account the state of health, the level of functional characteristics of physical fitness.

Literary data testify to the reality of restoration of the functional capabilities of an aging organism in the process of health-improving physical culture [12; p. 119, 10; p.23, 27].

At the same time, there is an increase in the quality of their life, a decrease in the risk of falls, cardiovascular diseases, normalization of cholesterol and lipoprotein parameters, an increase in the body's resistance, physical strength and endurance, a decrease in depression [15; p. 129, 16; 288].

Analysis by E.N. Medvedeva. et al. (2015) testifies that older women prefer to engage in dance aerobics, which, however, gives too much workload, the exercises conducted using oriental systems have a low level of exercise, while the groups of women were formed without taking into account age characteristics [8; p.128-135]

Some authors believe that with aging, the adaptive capabilities of the body decrease, which are largely associated with age-related changes in the neurohumoral regulation system, cardiovascular system, immune reactivity, as well as a decrease in muscle strength and endurance [4; p. 23-27, 11; p. 247, 12; p.119].

In the literature there are different opinions on the issue of age-related changes in women in the function of blood circulation during muscular activity [9; p. 191, 14; p. 19, 6; p. 133-161, 19; p.40-45].

It is believed that over the years, the effectiveness of the impact of training on the body decreases. So, a number of authors [13; p. 172, 14; p. 19, 18; pp. 30-35, 19; pp. 40-45] came to the conclusion that when performing the same training program, its effect on the body of young people will be more effective than its effect on the body of 50-60-year-old people. Obviously, training causes an expansion of the functional range of individual organ systems in people of 60-70 years of age, but the phenomena of adaptation in this case proceed in a peculiar way [20; p. 245].

## BIBLIOGRAFY

1. Bakhmetova G.Sh. Modern problems of population aging in the world: trends, prospects, relationships between 22. generations / ed. G. Sh. Bakhmetova, L.V. Ivankova. M.: MAKSPress, 2004.229 p.
2. Vladimirov D.G. The older generation as a factor of the economic 13. development of Russia // Sotsiol. issled. 2004. No. 4. pp. 57-60.
3. Gavrilov, D.N. Pedagogical and organizational features of the motor regime of people of mature and elderly age / D.N. Gavrilov, A.G. Komkov, A.V. Malinin [et al.] // Theory and practice of physical culture. - 2002. - No. 4. - pp. 44-47.
4. Gavrilova, N.Ye. The influence of the aging of the population of Russia on the course of diseases / N.Ye. Gavrilova // Disease prevention and health promotion. - 2006. - No. 1. - pp. 23-27.

5. Godin, E.Z. Dynamics of the processes of growth and development in humans: spatio-temporal aspects: author. dis. ... Dr. biol. Sciences: 03.03.02 / Godina Elena Zinovievna. - M., 2001. -- 50 p.
6. Godin, E.Z. Human body and social status / E.Z. Godin // Ethology of man and related disciplines. Modern research methods / ed. M.JI. Butovskoy. - M. : Institute of Ethnology and Anthropology of the Russian Academy of Sciences, 2004. - pp. 133-161.
7. Godin, E.Z. Intergroup differences in the complex of morphofunctional indicators in men of three ethnic groups under normal conditions and under hypothermic experiment / E.Z. Godin, JT.B. Zadorozhnaya, I.A. Khomyakova, A.JI. Purunjan // Bulletin of Moscow University. Series XXIII. Anthropology. 2009. № 1. pp. 54-65.
8. Godin, E.Z. Secular trend: history and prospects / E.Z. Godin // Human Physiology. 2009. T. 35. No. 6. P. 128-135.
9. Deryabin, V.E. Geographic features of the body structure of the population of the USSR / V.E. Deryabin, A.L. Purunjan. - M. : Publishing house of Moscow State University, 1990. - - 191 p.
10. Zuev E.G. Somatotypological osornosti in men of mature age with degenerative-dystrophic diseases of the spine: author. dis. ... Cand. honey. sciences. Tyumen, 2009.23 p.
11. Kaznacheev, V.P. The health of the nation. Education. Education. - M. ; Kostroma, 1996 - 247s.
12. Kaznacheev V.P., Kaznacheev S.V. Human adaptation and constitution. Novosibirsk: Nauka, 1986.119 p.
13. Kitmanov, V.A. Physiological bases of adaptation of the human body to physical activity: Textbook. / V.A. Kitmanov, G.I. Deryabin. -Tambov: TPOO "Business-Science-Society", 2011. - 172 p.
14. Kortava, J.C. The technology of using strength exercises and hardening in the health improvement of women of the first mature age [Text]: author. dis. ... Cand. ped. Sciences: 13.00.04 / Kortava Zhanna Georgievna. - M., 2000. -- 19 p.
15. Kossinskaya, N.S. Processes of natural and pathological aging / N.S. Kossinskaya. - L. : Medgiz, 1984. -- 129 p.
16. Krasnova, O.V. Social psychology of old age / O.V. Krasnova, A.G. Leaders. - M., 2002. -- 288 p.
17. Screamer, E.H. Factors of variability of morphological and functional indicators of the child's body: monograph. / E.H. Screamer. - Belgorod: BelGU Publishing House, 2008.-200 p.
18. Kryazhev, V.D. The program of health-improving trainings with women of 60-70 years of age using dynamic exercises of Kundalini Yoga / sec. 30-35
19. Kryazhev, OV Zaikina, N.A. Gross // Bulletin of sports science. -2013.-№ 2.-P. 40-45.

20. Kurova, T.V. Content and methodology of health-improving gymnastics classes with elderly women in the sphere of mental labor: dis. ... Cand. ped. Sciences: 13.00.04 / Kurova Tatyana Vitalievna. - SPb., 2016.-245 p.
21. Kuchma V.R., Dontsov V.I., Krutko V.N. and others. Stages of human life and 17. health services in different age periods. M.: Academy, 2002.396 p.
22. Matyukhin V. A. Ecological human physiology and restorative medicine / V.A. Matyukhin, A.N. Razumov. M., Medicine, 2009.346 p.



**ACADEMICIA**  
**An International  
 Multidisciplinary  
 Research Journal**  
 (Double Blind Refereed & Peer Reviewed Journal)

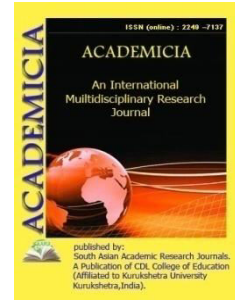

**DOI: 10.5958/2249-7137.2021.01873.5**

## THICKNESS OF EPICARDIAL ADIPOSE TISSUE AS A PREDICTOR OF CARDIOVASCULAR RISK

**Orziqulova Sh. A\***

\*Department of Internal Medicine and Endocrinology,  
 Bukhara State Medical Institute named after Abu Ali ibn Sina,  
 UZBEKISTAN  
 Email id: orziqulovashaxlo@gmail.com

### ABSTRACT

*Epicardial fat is one of the most discussed and unexplored risk factor for cardiovascular disease. Structure of epicardial adipose tissue, it's functions and pathophysiological processes are observed. It is considered epicardial fat to increase cardiovascular risk. Currently, there is no standardized methodology for measuring the thickness of the epicardial fat. As the most accessible method, the method of transthoracic echocardiography is considered and described. The researchers suggested that the absence of the fascia separating the adventitia of the coronary arteries from the ECF may contribute to atherosclerotic lesions of the coronary arteries to a greater extent due to the paracrine effect of the ECF itself than from the processes of the systemic inflammatory process. At the same time, these studies are characterized by laboriousness, the need for specially trained personnel, high cost and, in the case of MSCT, radiation exposure for the patient, which significantly limits the possibility of their widespread use in clinical practice to assess the severity of epicardial obesity. Sacks et al. Pioglitazone therapy was associated with a lower expression of pro-inflammatory genes, in particular interleukin-1b, in the ECF in patients with type 2 diabetes (DM 2) and coronary artery disease. There is evidence that the volume and thickness of the EFT are associated with the degree and severity of metabolic syndrome and IHD, therefore, the measurement of the EFT thickness can be used as a prognostic marker of cardiometabolic diseases.*

**KEYWORDS:** *Epicardial Fat, Cardiovascular Disease, Cardiovascular Risk, Echocardiography.*

## INTRODUCTION

Obesity, which has received the status of a non-communicable pandemic of the 21st century, is becoming one of the main public health problems, contributing significantly to premature mortality, increasing the cost of medical care and worsening the quality of life of patients. According to the multicenter observational study ESSE-RF, in 2012-2013 the prevalence of obesity in the Russian population reaches almost 30%, our country ranks fourth in the world in terms of the number of obese persons.

The results of numerous studies have shown that visceral fat is a hormonally active tissue that produces a large number of biologically active substances - adipokines involved in the development of metabolic disorders, inflammation and fibrosis, thrombus formation and atherogenesis, and the severity of VAT and the degree of its dysfunction are a key factor determining the nature of the obesity phenotype: complicated ("metabolically unhealthy") or uncomplicated ("metabolically healthy") obesity.

Epicardial adipose tissue (EFT) is located between the myocardium and the visceral pericardium, mainly behind the free wall of the right ventricle, in the atrioventricular and interventricular grooves, accounting for about 20% of the total weight of the ventricles of the heart, is of mesodermal origin and is supplied by the branches of the coronary arteries. Characteristic is the absence of the fascia separating the EFT and the underlying myocardium, which determines the presence of a single microcirculation system. EFT is a source of various biologically active substances that can affect the myocardium and coronary arteries through paracrine and vasocrine secretion.

Among them, pro-inflammatory and atherogenic adipokines are distinguished (tumor necrosis factor- $\alpha$ , monocyte chemoattractant protein-1, interleukins (1, 1 $\beta$ , 6, 8), plasminogen activator-1 inhibitor, phospholipase-A2 of the second type, mitogen-activated protein kinase, chemokine, secreted by T-cells upon activation, intercellular adhesion factor, P-selectin, E-selectin and others), VAT markers (leptin, resistin, omentin, visfatin), profibrotic adipokines (activin A, transforming growth factor- $\beta$ 1), growth factors and remodeling of the heart and blood vessels (angiotensin-II, angiotensinogen, vascular endothelial growth factor, nerve growth factor), thermogenesis factors (uncoupling protein-1), as well as anti-inflammatory adipokines (adiponectin, adrenomedullin).

At the same time, the level of expression of most adipokines by adipocytes of epicardial fat is much higher than that of other visceral fat depots. EFT adipocytes also differ in size compared to adipocytes of subcutaneous fat and other visceral fat depots, a higher rate of uptake and release of free fatty acids, the excessive accumulation and oxidation of which in various pathological conditions can lead to the development of the phenomenon of "lipotoxicity".

The Framingham Heart Study and the Multi Ethnic Study of Atherosclerosis announced that ECF volume is an independent predictor of the risk of coronary heart disease (CHD). T. Mazurek et al. published data indicating the pro-inflammatory effect of ECF. Having studied biopsies of subcutaneous adipose tissue and ECF of patients with coronary artery disease who underwent coronary artery bypass grafting, the researchers found that the expression of proinflammatory cytokines in ECF is several times more pronounced than in subcutaneous adipose tissue. In addition, it was found that in the ECF of patients with progressive coronary artery disease, there are more proinflammatory macrophages of the M1 type (classically activated) and fewer anti-

inflammatory macrophages of the M2 type (alternatively activated) compared with persons without coronary artery disease. The researchers suggested that the absence of the fascia separating the adventitia of the coronary arteries from the ECF may contribute to atherosclerotic lesions of the coronary arteries to a greater extent due to the paracrine effect of the ECF itself than from the processes of the systemic inflammatory process. One of the newest directions in the study of ECL is the study of the effect of drug therapy, in particular some antidiabetic drugs and statins, on the severity of ECI. Thiazolidinediones increase tissue sensitivity to insulin by acting on adipose tissue, muscle and liver, where they increase glucose utilization and decrease glucose synthesis. Sacks et al. Pioglitazone therapy was associated with a lower expression of pro-inflammatory genes, in particular interleukin-1b, in the ECF in patients with type 2 diabetes (DM 2) and coronary artery disease. In another study, it was shown that an agonist of g-receptors activated by peroxisome proliferators, rosiglitazone, can induce rapid dissolution of ECF in experimental models. An analogue of glucagon-like peptide-1, liraglutide, in patients with diabetes mellitus 2 and obesity led to a significant decrease in the thickness of the ECF according to echocardiography from  $10.2 \pm 2$  to  $6.9 \pm 1.9$  mm after 12 weeks and to  $5.8 \pm 1.9$  mm ( $p < 0.001$ ) after 24 weeks of therapy. The dynamics of the ECL did not depend on a decrease in body weight and an improvement in the glucose profile. In a study by S. Morano et al. similar data were obtained on a decrease in the thickness of the ECF after 12 weeks of therapy with liraglutide or exenatide in patients with diabetes mellitus 2. Methods of the "gold standard" for EFT imaging, which allow assessing both the thickness in different parts of the heart and the total volume, include MSCT and MRI. At the same time, these studies are characterized by laboriousness, the need for specially trained personnel, high cost and, in the case of MSCT, radiation exposure for the patient, which significantly limits the possibility of their widespread use in clinical practice to assess the severity of epicardial obesity. In 2003 Iacobellis G, et al. first described a method for quantifying EFT using transthoracic echocardiography. The thickness of the epicardial fat, which is visualized as an echo-negative space between the free wall of the right ventricular myocardium and the visceral layer of the pericardium, was determined perpendicular to the free wall of the right ventricle in B-mode (parasternal position, along the long axis of the left ventricle), at the end of the systole along the line as perpendicular as possible the aortic ring (the site of origin of the ascending aorta), which was used as an anatomical landmark. The authors of the method proposed to evaluate this indicator at the end of the ventricular systole, since during diastole the compression of the EFT leads to an underestimation of the EFT value, and also complicates its differentiation from the pericardial adipose tissue located outside of the parietal pericardium. Subsequently, the presence of a high correlation between the echocardiographically determined TED and the volume of EFT according to MRI data was demonstrated (0.91, 1, with the amount of abdominal IVT according to MSCT data, as well as the amount of intramyocardial fat measured using proton magnetic resonance spectroscopy (0.79,  $p = 0.01$ ), which gives grounds to consider this indicator as a marker of both epicardial obesity and visceral obesity in general. It should be noted that numerous clinical studies have shown differences in the average values of echocardiographically determined EAT in individuals without metabolic disorders and CVD, depending on ethnicity, indices of indirect evaluation of TD, as well as the age of patients, which suggests the presence of determinants of the indicator, which should be taken into account when determining the threshold values of the EAT as a criterion for epicardial (visceral) obesity.



Thus, in the course of the population prospective cohort study The Heinz Nixdorf Recall Study (n = 4093, 47% of men, average age of patients 59.4 years, follow-up period was  $8.0 \pm 1.5$  years), it was shown that the frequency of fatal and non-fatal cardiovascular events increased with an increase in the volume of EFT according to MSCT data, amounting to 0.9% and 4.7% for the value of EFT in the first and fourth quartiles, respectively ( $p < 0.001$ ), while doubling the volume of EFT was associated with a 1.5-fold increase CVD risk regardless of traditional CVR factors. The same study revealed the relationship of EFT with the dynamics of coronary artery calcification based on a two-fold analysis of the coronary calcium index, performed with a five-year interval. An increase in the volume of EFT by one standard deviation was accompanied by an increase in the indicator by 6.3% (95% CI 2.3-10.4%,  $p = 0.0019$ ). In CVD-asymptomatic individuals with obesity verified on the basis of BMI and / or central (abdominal) obesity verified on the basis of threshold values for OT, the experts of the European Society of Cardiology consider it appropriate to conduct a systematic assessment of CVR, suggesting an assessment as a basic stratification tool. risk on the SCORE scale. At the same time, both obesity by BMI and central obesity are considered in these recommendations as factors that increase the initially determined risk on the SCORE scale. Currently, the most accessible method for verifying visceral obesity is the diagnosis of epicardial obesity based on echocardiographic evaluation of TEF according to the method described above. To establish the threshold value of this indicator, taking into account the presence of an association with various factors (determinants) (age, BMI, ethnicity, and others), additional research is needed, possibly within the framework of an appropriate register. At the same time, on the basis of the already available research results, the following TEF values can be proposed as a criterion for epicardial (visceral) obesity:  $\geq 5$  mm for people under 45 years old,  $\geq 6$  mm for people from 45 to 55 years old,  $\geq 7$  mm for people older 55 years. Currently, there is no threshold value for the thickness of the EFT. In the literature, there are many contradictions regarding the thickness of the EFT and the degree of its influence on the progression of cardiovascular diseases. It seems interesting that the thickness of the EFT, measured during the end systole, is a minimum of 1.1 and a maximum of 22.6 mm, with an average value of 7 mm in men and 6.5 mm in women (in healthy volunteers). When measured at the end of diastole, the mean value of the EFT thickness was 6.4 mm (1.1–16.6 mm) in patients with coronary artery disease and  $4.7 \pm 1.5$  mm in asymptomatic patients. EFT thickness, measured at the end of diastole, more than 5 mm is considered as an independent predictor of the development of subclinical atherosclerosis, metabolic syndrome, low coronary reserve and hypertension. At the same time, the indicated value of the EFT thickness cannot be considered as a threshold value, since this has not been studied in large multicenter studies. When interpreting the obtained values of the EF thickness, it should be borne in mind that the EFT thickness can be influenced by age, gender, race, and in what phase of the cardiac cycle the measurement was performed. In addition, it should be remembered about a number of technical limitations of echocardiographic assessment of the EFT thickness, in particular, the greater interobserver variability compared to CT and MRI, as well as the transthoracic acoustic window, which limits the possibilities of EF visualization. Despite these difficulties, echocardiography remains the main method for measuring EFT. Echocardiographic determination of TED is undoubtedly important for secondary prevention in obese patients. In particular, in order to form a high-risk group of complications before carrying out planned myocardial revascularization, to identify a higher risk of CVC in patients undergoing acute coronary syndrome, to optimize preventive measures. In patients with atrial fibrillation, the assessment of EFT as an

etiopathogenetic factor in the development of structural and functional atrial remodeling will be useful for resolving the issue of the volume of up-stream therapy of the disease.

## CONCLUSION

EFT is a special visceral fat depot with unique anatomical and functional capabilities. It is an important source of biomolecules, which also serves as a secretory organ. EF thickness and volume can be measured using echocardiography, CT, or MRI. There is evidence that the volume and thickness of the EFT are associated with the degree and severity of metabolic syndrome and IHD, therefore, the measurement of the EFT thickness can be used as a prognostic marker of cardiometabolic diseases. Unfortunately, to date, there are no results of large population studies on the effect of EFT on the development and progression of ischemic heart disease. These studies are expected to lead to new therapeutic approaches for the treatment of cardiovascular disease.

## LITERATURE

1. Sacks H.S., Fain J.N. Human epicardial adipose tissue: a review. *Am. Heart J.* 2007; 153: 907–917. DOI: 10.1016/j.ahj.2007.03.019.
2. Iacobellis G., Willens H.J. Echocardiographic epicardial fat: a review of research and clinical applications. *J. Am. Soc. Echocardiogr.* 200
3. Baritdinova M.N. Orziqulova Sh.A. THE PREVALENCE OF ABDOMINAL OBESITY AMONG THE POPULATION AS THE MAIN CRITERION OF THE METABOLIC SYNDROME. ISSN 2249-7137 Vol. 10, Issue 11, November 2020 Impact Factor: SJIF 2020=7.13
4. Orziqulova Shaxlo. CHRONIC OBSTRUCTIVE PULMONARY DISEASE AND THE METABOLIC SYNDROME: THE STATE OF THE PROBLEM. DOI: 10.5958/2249-7137.2021.01615.3. ISSN: 2249-7137 Vol. 11, Issue 6, June, 2021 Impact Factor: SJIF 2021 = 7.492
5. Pezeshkian M, Noori M, Najjarpour-Jabbari H et al. Fatty acid composition of epicardial and subcutaneous human adipose tissue. *Metab Syndr Relat Disord* 2009; 7 (2): 125–31.
6. Prati F, Arbustini E, Labellarte A et al. Eccentric atherosclerotic plaques with positive remodelling have a pericardial distribution: a permissive role of epicardial fat? *Eur Heart J* 2003; 24: 329–36.
7. Berg AH, Scherer PE. Adipose tissue, inflammation, and cardiovascular disease. *Circ Res* 2005; 96 (9): 939–49.
8. Mazurek T, Zhang L, Zalewski A et al. Human epicardial adipose tissue is a source of inflammatory mediators. *Circulation* 2003; 108 (20): 2460–6.
9. Ito T, Nasu K, Terashima M et al. The impact of epicardial fat volume on coronary plaque vulnerability: insight from optical coherence tomography analysis. *Eur Heart J Cardiovasc Imaging* 2012; 13 (5): 408–
10. Sacks HS, Fain JN et al. Uncoupling protein-1 and related messenger ribonucleic acids in human epicardial and other adipose tissues: epicardial fat functioning as brown fat. *J Clin Endocrinol Metab* 2009; 94 (9): 3611–5.

11. KI Juraeva, BK Badridinova, BS Kadirov, MA Majidova, KS Yakhyaeva, Frequency of meeting the main components of the metabolic syndrome during disturbance of different phases of glycemic curve...ACADEMICIA: An International Multidisciplinary Research Journal 9 (1), 80-85
12. X.Ш Яхъяева. Сахарный диабет 2-го типа у детей и подростков бухарской области. //Биология и интегративная медицина //2021.—Р. 139-145.

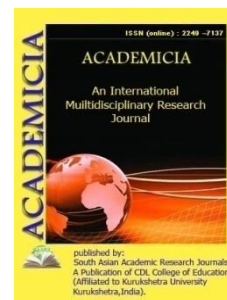
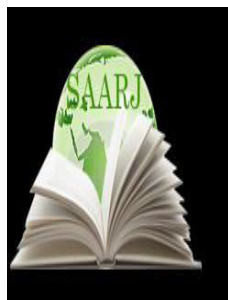

DOI: **10.5958/2249-7137.2021.01874.7**

## THE INVESTIGATION OF ALL POSSIBLE STRUCTURES OF PHRASEOLOGICAL UNITS WITH PROPER NAMES

**Rakhimova Nigora Sobirjonovna\***

\*English Teacher,  
Samarkand State Institute of Foreign Languages,  
Samarkand, UZBEKISTAN

### ABSTRACT

*The present article is devoted to investigation of English phraseological units with proper names as well as to study of their possible structures. All structures are proved by examples. The frequency of usage of these structures is also pointed in the article. The data of lexicology make it possible to determine the nature of the components of PUs. The theory of lexical meaning developed in semantics helps to identify the semantic specificity of PUPrN and to distinguish various types of meaning in the sphere of phraseology. Moreover, proper names in PUs have specific function. From grammatical point of view their function in the sentence is expressed by subject and complement, lexical function is nomination. Historically, their function is informative. The data of syntax is very important to identify the grammatical specifics of these word combinations - their grammatical structure and functions.*

**KEYWORDS:** *Phraseological Unit, Proper Name, Grammatical Structure, Model, Semantics, Origin.*

### INTRODUCTION

#### Actuality of the theme of the research

There are idioms, proverbs, sayings, containing proper names. They originated from people's lifestyle, customs and traditions, prose and poetry, mythology, fairy stories, fables, songs, slang, novels and other sources [6]. It should be stressed, though, that proverbs or phraseological units with proper names (further PUPrN) are used in speech or writing often [1]. Also, some proverbs comprising people's names, names of ethnicities, cities or countries, may be perceived as offensive stereotypes, and should be avoided. All this makes the theme of research actual and important among the problems of modern linguistics. It is not less significant than learning

grammar, lexis and pronunciation. By knowing them we can differentiate positive and negative sides of humanity.

The investigation of PUPrN is one of the insufficiently explored fields of the modern linguistic study. Undeniable, that this research involves two branches of linguistics, at first sight phraseology and onomastics at the second. Phraseology connected with the history, literature and linguistics, but primarily with the linguistic disciplines: lexicology, semantics, grammar, phonetics, stylistics, history of language, etymology, text linguistics and general linguistics [2]. PUPrN consist of words, and the word is the main object of the study of lexicology. The data of lexicology make it possible to determine the nature of the components of PUs. The theory of lexical meaning developed in semantics helps to identify the semantic specificity of PUPrN and to distinguish various types of meaning in the sphere of phraseology. The word in phraseology does not always lose its morphological features, morphology helps to determine what is lost and what is preserved. Composition of PUPrN includes the combinations of different structural types, including PUPrN with the structure of phrases and sentences. The data of syntax is very important to identify the grammatical specifics of these word combinations - their grammatical structure and functions. The word in the phraseology is characterized by a certain phonetic form, but in the process of development it can also change.

Besides, it relates to cognitive linguistics, pragma-linguistics, linguoculturology, sociolinguistics. Apart linguistic subjects it concerns as well as non-linguistic ones, namely literature, history, ethnography, mythology, anthropology.

**The aim of the research** is to investigate the semantic peculiarities of English phraseological units with proper names as well as to study their structures.

**The object of the research** is English phraseological units and proverbs containing proper names in their semantic structures, their historical, cultural and structural peculiarities.

The following **methods of inquiry** were used in the work:

- descriptive method (to describe main points of the research work),
- componential analysis (to take component: proper name out of the whole phraseological unit or proverb and analyze it),
- cognitive-conceptual analysis (to investigate associations, background knowledge in phraseological units and proverbs with proper names),
- Lingual-cultural analysis (to find out interesting cultural events which deal with phraseological units and proverbs with proper names).

## DISCUSSION AND RESULTS

Phraseological units with proper names contain special group among phraseologies. They have certain grammatical structural patterns. To investigate structure PUPrN it is required to observe structural patterns of phraseological units themselves. Few linguists had investigated grammatical structural models of phraseological expressions and it can be found suitable structural patterns for PUPrN. In her book "Comparative analysis of phraseological units", Arsentjeva offered the following structures of phraseological units (further we'll use abbreviation PUs):

1. PUs with phrase structure
2. PUs with sentence structure

Phraseologies with phrase structure are divided into the following types:

- a) Verbal PUs
- b) Substantial PUs
- c) Adjectival PUs

The largest class is the class of the verbal PUs, gone after substantive and adjectival phraseologies and PUs with sentence structure.

### The verbal Pus

The verbal PU is phraseologies which functionally correlated with the verb, in other words, the nuclear constituent of phraseology is a verb. There is objective relation between nuclear element and dependent subordinated PUs. The following main subclasses are distinguished:

**1.** The subclass **verb +noun**, for example, *raise Cain, shoot Niagara, to cross the Rubicon, To astonish the Browns, To sham Abraham, take the Mickey, be a Gypsy, discover America, to speak BBC, go Dutch.*

To this same subclass of FE we include a subspecies of PUs with a prepositive extension of a noun with possessive pronouns.

- a) The subclass **verb+pronoun+noun**, for example, *meet one's Waterloo.*
- 2.** Phraseological structure **verb+adjective+noun**. A typical feature of phraseologies with this structure is that they contain adjective. For example, *cut the Gordian knot*, here the word "Gordian" fulfills the role of adjective, *be a Spanish village- be totally unknown to somebody, be a real/true Gypsy, have green fingers, take French leave, have kissed the Blarney Stone* [3].
- 3.** The subclass with the most numerous phraseologies has the structure **verb +preposition +noun**, for instance, *go over to Rome, go for a Burton, be off to Bedfordshire, go to Canossa, keep up with the Joneses, be from Missouri*. This is postpositive extension.
- 4.** Phraseologies with the structure **verb +preposition +pronoun +noun**. This model considers extension of noun with help of possessive pronouns.
- 5.** Phraseologies with the structure **verb +preposition +adjective +noun**. This structure suggests extension of noun due to the adjective,
- 6.** The class **verb +noun +preposition +noun**, for instance, *bend the bow of Ulysses, carry coals to Newcastle, live the life of Riley, built castles in Spain, pile/heap Pelion on Ossa, throw a sop to Cerberus* [3]. In this class, the first dependent component is a direct object, the second is an indirect object. It can be observed expansion of both dependent components with help of adjectives and possessive pronouns, subclasses

**verb +pronoun + preposition +noun**, for example, *row somebody up Salt River, tell it not in Gath, not know someone from Adam, see somebody at Jericho first;*



**verb +noun +preposition +pronoun**, e.g. *come Yorkshire over somebody, be Greek to somebody*;

7. Subclass **verb +adjective**. There is no PNPrN in this class, because proper names play the role of noun in phraseologies.

8. Subclass **verb +noun +adjective**. This subclass is characterized by complex objective postpositive type.

9. Subclass **verb +comparative +noun** is small. Role of comparative component performs words “like” or “as”. To exemplify, *drive like Jehu*;

a) **Verb +comparative +adjective +noun**, e.g., *laugh like little Audrey, grin like a Cheshire cat; fight like Kilkenny cats*;

b) **Verb +comparative +noun + preposition +noun**, e.g., *be like Hamlet without the prince, be like the Black Hole of Calcutta, feel like Daniel in the lion's den*;

10. Subclass of verbal PUs with subordinating sentences, e.g., *fiddle while Rome is burning, Is rotten in the state of Denmark*.

**Substantial PUs**. Substantial Pus are phrases functionally correlated with the noun, i.e., the core component of phraseology is a noun [5].

There are following subclasses of substantial PUs:

1. Subclass with structure **adjective +noun** is characterized by attributive connection between components. Distinctive feature of it is an interchangeability of components, e.g. *a Roman holiday, old Hickory, a Dear John, a Trojan horse, the real McCoy, Black Maria*. This subclass has two forms:

a) Adjectival-nominal group, e.g. *long Tom, clever Dick, great Caesar!*;

b) Substantial- nominal group, e.g. *Hermes fire, an April fool, Cordelia's gift, a Barmecide feast*;

2. Subclass with the structure **noun +noun**, it is noted that in English Pus the use of the proper name are both core and dependent components: *a Mark Tapley, King Log, Iack Horner, a Miss Nancy, Colonel Chinstrap, Colonel Blimp, Mother Bunch*.

These PUs are characterized by an attributive-prepositive type with an adjunction to the substantive-nominal group, in which the dependent component is expressed by a noun without any morphological design: *a Cadmean victory*.

3. Subclass with structure **noun +preposition +noun**. In this case, combination of noun with noun is carried out through prepositional subordinating connection, e.g. *the tower of Babel, the vicar of Bray, the sword of Damocles*. The second member of such phraseologies can be extended due to usage of adjectives **noun +preposition + adjective +noun**, e.g., *Father of English poetry* or **noun +preposition + noun +noun**, e.g., *the Duke of Exeter's daughter* [4].

The structure **noun +preposition +noun** is possible for both singular and plural forms, for example, *Jack of all trades*.

Following prepositions are used for forming phraseologies of that type:

**of**, e.g. *the labours of Hercules*

**on**, e.g. *the man on the Clapham omnibus*

**for**, e.g. *a Roland for an Oliver*

**in**, e.g. *Alice in Wonderland*

Other prepositions are used very rare.

4. Subclass with the structure **Participle I or II +noun**, for example, *a doubting Thomas*, *waiting Matilda*.

Phraseologies of this type in the English language correspond to the PUs of the participial-nominal group of the attributive-prepositive type with an adjunction in which the dependent component is expressed by participle.

5. Subclass with the structure **noun +and +noun**, which is characterized by coherent relation between components, e.g. *Lares and Penates*, *Castor and Pollux*, *Gog and Magog*, *Darby and Joan*, *Tom and Jerry*.

In English, there are PUs with the structure **preposition +noun** with a prepositional extension of the noun with an adjective or a numeral. The core component of such PUs is noun, but they can serve as an adjective and adverb in the sentence. For instance, *by Jove!*, *by Jupiter!*, *according to Cocker*, *by the Lord Harry!*

**Adjectival PUs.** Adjectival PUs are considered functionally correlated with adjectives. The core component in these PUs is an adjective, the dependent component is a noun. **Adjective +as +noun**, e.g. *patient as Job*, *proud as Lucifer*, *pleased as Punch*, *happy as Larry*, *hot as Hades*, *old as Adam*, *poor as Lazarus*, *rich as Croesus*.

**PUs with structure of sentence.** There are PUs with the structure of sentence but their number is small. Characteristic feature for both English is PUs constructed according to the structure of a simple sentence and having components which are related as subject and predicate. *He thinks himself God Almighty*; *Daniel comes to judgment*; *the Dutch have taken Holland*; *fiddle while Rome burns*.

As a rule, PUs based on the structure of complex and compound sentences are proverbs and sayings.

Another linguist I.V. Arnold divided expressions according their function into several types:

1. Expressions performing the function of noun:

**Noun +noun**, e.g. *the Royal Alfred*, *Aunt Fanny*, *Uncle Tom*, *Madison Avenue*, *Botany Bay*, *Annie Oakley*, *Tommy Atkins*;

**Noun's +noun**, e. g. *Pandora's box*, *Naboth's vineyard*, *Salomon's wisdom*, *Penelope's web*, *Cleopatra's needle*;

**Nouns' +noun**, e.g. *Achilles' heel*, *Achilles' spear*, *Nessus' shirt*;

**Noun +preposition +noun**, e.g. *the cask of Danaides*, *the brand of Cain*;

**Noun +and +noun**, e.g. *Alpha and Omega*;

**Adjective +noun**, e.g. *a Smart Aleck*;

2. Expressions performing the function of verbs:

**Verb +noun**, e.g. *raise Cain*;

**Verb + (one's) +noun +(preposition)**, e.g. *meet one's Waterloo*;

**Verb +subordinate clause**, e.g. *fiddle while Rome burns*;

3. Expressions performing the function of adjectives:

**Adjective +as +noun**, e.g. *happy as Larry*;

Such kind expressions frequently used as predicates, but not as attributes.

4. Expressions performing the function of adverbs:

**Noun +and +noun**, e.g. *David and Jonathan*;

**Preposition +noun**, e.g. *according to Hoyle*;

**Preposition +noun +and +noun**, e.g. *between Scylla and Charybdis*;

**Conjunction +noun**, e.g. *before you can say Jack Robinson*.

In English speech there is also a significant number of unconditional formations, at first glance, which correspond to certain features of PUs, but in reality significantly differ from them. We are referring to formation, which can be called a standard style of grammatical constructions. Before turning to their consideration, it is regarded to pay attention to some of the most important peculiarities of phraseological units derived from their essence as units of a permanent context.

The first feature. Since the result of the basis of a permanent context is the emergence in it of the phraseologically related meaning of one of the parts or the content of the whole unit. This has lexical meaning rather than grammatical.

The second feature. There is no language pattern that defines both the material structure, and specific semantic result of the verbal structure reproduced on it. The structure of any constructional type of PUs is a basic syntactic rule for constructing a word combination, which does not provide for any other idiomatic content than originally intended. The only simulated thing was that the variable word combination which, over time, under certain conditions, turned into a PU.

The third feature. The lexical meaning of every PU is individual, and not typical.

Thus, PUPrN have a certain structural and grammatical form constructed according to models of free slangs or sentences existing in one or another language.

It is known that the phraseological units' structures do not differentiate from the common phrase. They are based on the model of some free syntactic constructions existing in the language at present or existed in the past. It is clear that PUPrN have different structural models, however, there is PUs not corresponding to any structural models, they have unique structure.

## CONCLUSION

PUPrN contain special group among phraseologies. They have certain grammatical structural patterns. There are offered the following structures of phraseologies:

1. PUs with phrase structure

## 2. PUs with sentence structure

Phraseologies with phrase structure are divided into the following types:

- a) Verbal PUs
- b) Substantial PUs
- c) Adjectival PUs

In English speech there is also a significant number of unconditional formations, at first glance, which correspond to certain features of PUs, but in reality significantly differ from them. We are referring to formation, which can be called a standard style of grammatical constructions. Before turning to their consideration, it is regarded to pay attention to some of the most significant features of PUs derived from their essence as units of a constant context.

Moreover, proper names in PUs have specific function. From grammatical point of view their function in the sentence is expressed by subject and complement, lexical function is nomination. Historically, their function is informative. In the speech, depending on the situation, they can serve as the basis of message or have communicative function. Proper names in the structure of PUs can be used as appeal or appellative function and as expressive means or expressive function. Identification, address, deixis, appeal, emphasizing, listing, differentiation, description are peculiar refinement and division of communicative function, and not separate function of names. Ideological and emotional functions are main functions of proper names in the structure of PUs, because they convey the whole essence of phraseology. Becoming part of the PU, the proper name loses its connection with a particular person or object i.e. exhausts its onomastic function. It ceases to express singularity and begins to generalize, and therefore, to perform the function of common noun.

In addition, the etymological ground of PUs in modern English is very diverse. Origin of English phraseologies can be divided into two classes: native and borrowed English PUs. Borrowed PUs are subdivided into: inter-lingual and intra-linguistic.

Thus, it is clear that in modern English, PUPrN differ according to their grammatical structure, their function in the sentence and etymological ground.

### LITERATURE:

1. Arsentieva E.F. Phraseology and phraseography in a comparative aspect (based on the English and Russian languages). - Kazan: Leningrad State University, 2006. -- 126 p.
2. Kunin A.V. A course of phraseology of modern English. - 2nd ed. revised - Moscow: Higher school, 1996. -- 156 p.
3. Kunin A. V. *Anglo-Russian phraseological dictionary*. - Ed. 3rd, rev., In two books. -M.: SE, 1967. - T.1.- 738s. ; T.2. - 739 - 1264 p. (ARFS)
4. Altenberg Bengt. On the Phraseology of Spoken English: The Evidence of Recurrent Word-Combinations // *Phraselogy*. Ed. A.P.Cowie. – Oxford: Clarendon Press, 1998. – 204 p.
5. Álvarez de la Granja, María (ed.). *Fixed Expressions in Cross-Linguistic Perspective. A Multilingual and Multidisciplinary Approach*. – Hamburg: Verlag Dr. Kovac, 2008. – 142 p.
6. Anderson John M. *The Grammar of Names*. Oxford: Oxford University Press, 2007. – 197 p.

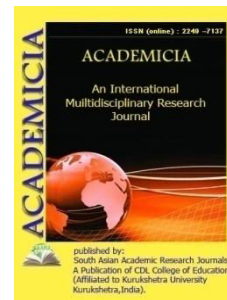
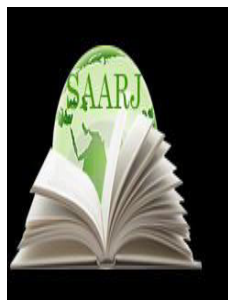

DOI: [10.5958/2249-7137.2021.01875.9](https://doi.org/10.5958/2249-7137.2021.01875.9)

## INTERPRETATION OF PHONETIC EVENTS IN UZBEK AND TURKISH LANGUAGES

Mirzayeva Gozal Qobuljonovna\*

\* Independent Researcher  
 “Tong Press Print” editor of the Publishing House,  
 UZBEKISTAN

### ABSTRACT

*In the article, we tried to cover the study of the sound system of Uzbek and Turkish languages, the interpretation and comparative analysis of phonetic phenomena in them. As well as reductions and concomitant phenomena associated with it, we analyzed the phenomena of prokopa, Singapore, apocopa, elizia, syneresis, phraseology in both languages, showing similar and different aspects. The vowel in the stressed syllable is manifested by its acoustic superiority over the unstressed syllable, the height of the voice, its strong intensity and the length in quantitative terms. And the vowel in the unstressed syllable is pronounced weak, that is, it is pronounced in intensity and shorter in quantity. The phonetics and phonology of the Uzbek language are inextricably linked with the literary pronunciation and language culture of the language. The linguist includes the following phonetic phenomena that occur due to reduction and are associated with: procopa, syncope, apocopa, elision, syneresis, haplogy. Of these reduction-related events, we considered only syncopane as a complementary type of distribution.*

**KEYWORDS:** *Phonetics, Phonology, Phoneme, Invariant, Correspondence, Strong Position, Weak Position, Acoustics, Reduction.*

### INTRODUCTION

On the slope of each language, first of all, the field of phonetics and Phonology occupies a wide place. When we compare Turkic languages with each other, we see their most distinctive side through the sound system. Especially with other Turkic languages, the phonetic-phonological level of the Uzbek language has its own peculiarities, which can be explained by the fact that the Uzbek language is not subject to *singarmonism* and the existence of the law of *singarmonism* in almost all other Turkic languages. As you know, according to the classification of Turkic languages, Uzbek belongs to the *qarluq* group, while Turkish belongs to the *Oguz* group, it is

necessary to study the current state of these languages, especially the current features of phonetic and grammatical levels, to clarify the laws of the development of these languages. To this end, lexical-semantic changes in the development of Uzbek and Turkish languages were studied in the following years as an object of a number of studies.<sup>1</sup>

### **Main part**

In Uzbek linguistics, a lot of scientific research on phonetics and Phonology has been carried out. Of them A.G'ulomov, H.Abdurahmonov, A.Abduazizov, H.Jamolhonov, J.Mamatovlar's his works are especially noteworthy.<sup>2</sup> It is known that the inseparable connection of Sciences is one of the constant requirements of science. In Particular, S.Otamirzayeva studied phonetics and medicine in her studies.<sup>3</sup> The works of Turkologist E.V. Sevortyan also contain some ideas about comparative phonetics.

Uzbek is one of the largest Turkic languages in the world. The phonetics and phonology of the Uzbek language are inextricably linked with the literary pronunciation and language culture of the language. Along with the great achievements of Uzbek linguistics today, there are many areas that have not yet been scientifically studied. In particular, phonetics and phonology have not been studied in a comparative aspect, and the field of neurolinguistics has not been developed as a cause of sound changes.

If we look at the history of phonetics and phonology of Turkic languages, we realize that many scientific views have existed since ancient times. For example, the great scholar Abu Rayhan Beruni studied languages centuries ago in a phonological comparative aspect, noting that there is a big difference in the phonological system of Hindi and Arabic and that there is some difficulty in giving Indian words in Arabic. To overcome this difficulty, he made a number of changes to the Arabic alphabet. Adds four letters (*p, ch, j, g*) using partial Persian. He also draws attention to the fact that in Persian the phonemes *b* and *v* can be freely exchanged at the beginning of a word, and thinks about the origin of some words on the basis of this exchange.

For example, the twelfth article is dedicated to *Abhal*. He points out that the Greek *barutanun* and *barutun*, the Syriac *barusa*, the Persian *burs* and *vurs*, the *zabulcha vurs* are called *gunda*, and that the pronunciation of the *b-v* phonemes in Persian is close to each other, so that they are often easily interchangeable.<sup>4</sup> It should be noted that Beruni's above-mentioned ideas are about the type of free exchange of the phenomenon of distribution, which means that the phenomenon of distribution was actually studied by our scientists in the IX-X centuries.

Abu Ali Ibn Sina's views on phonetics are reflected in his work *Asbob*. Although this work is devoted to the phonetics of the Arabic language, Persian, Turkish, and other language materials are also used in many places, especially in Chapter V. That is why Ibn Sina's work differs from other works in its coverage of phonetic issues. The "instrument" differs from the tradition of Arabic linguistics in that it does not address the issue of phonetic changes, but studies the physiological and acoustic properties of sounds. The play reveals similarities and differences between consonants that are close by articulation and differ in acoustic sign. For example, *k-g, q-g*. This suggests that correlative consonants were distinguished by Central Asian philologists centuries before N.S. Trubetskoy and used as a guiding principle in the definition of consonant phonemes.



In Ibn Sina's work, in direct observation, the abstract stage generalization (invariant) of this variant differs from the variant pronounced with various changes. In particular, the sounds r-r', l-l' state that there are two different forms of commonality. This is due to the change in the sounds that occur in the contrast type of the distribution. Ibn Sina explains his treatise in the following chapters:

1. About the causes of noise;
2. About the causes of speech sounds;
3. About the anatomy of the throat and tongue;
4. On the peculiarities of the emergence of some Arabic sounds;
5. About speech sounds like these
6. These sounds are heard in non-verbal movements<sup>5</sup>

For the first time in Mahmud Koshgari's work "Devonu lug'atit turk" phonetics of Turkic languages were studied in a comparative aspect. In this game, the phonetic discrepancy in the pronunciation of the Oguz and Kipchak tribes is shown. In particular, the phonetic aspect of the word "y" "in the beginning is indicated by examples of its alternation with" "j" in Oguz and clams:

<i>Turks:</i>	<i>O'g'uz's va qipchoq's</i>
<i>Yelkin(musofir)</i>	<i>elkin</i>
<i>Yinju (marvarid)</i>	<i>jinju</i>
<i>Yug'du (tuyaning uzun juni)</i>	<i>jug'du</i>

**Mahmud Kashgari phonemes have different options in the speech process, as well as provide information about various phonetic phenomena.**

Including, ishbo' (hard and thick pronunciation of sounds), imola (crochet pronunciation of sounds), ishmom (soft or thin pronunciation of sounds), g'unna's two views (ng, ng'), hayshum (nazalizatsiya), the arrival of the series of two vowels (geminatsiya), Sound Exchange (metateza), thinks about assimilation, dissimilation, drop in volume and increase in volume.<sup>6</sup>

XIX century Boduen de Kurtene correspondence<sup>7</sup> about the phonetic phenomenon that he divided as Mahmoud Koshgari gave information in the XI centuries, that is, between the Turks and the Oguz and the Kipchaks m-b(men-ben, mun-bun"sho'rva"), t-d (teve-deve"tuya") also showing that there is a phonetic compatibility such as.

While phonetics is a bottleneck to every facet of the field of phonology, we have no choice but to bring the theories of Trubetskoy. N.S.Trubetskoy through his work "osnovi fonologii" extensively studied phonology. As the scientist gives the classification of sounds, he brings two, three, four variants and oppositions of each sound. For example, such as b-p, g-k, d-t. It bases the opposite cases of hens into four types. Trubetskoy links the position of the hounds with their distributive status.

- i. the sound in a strong position is that the core differs from each other by one vowel, without any addition to the word: *сам- сом*;
- ii. And the sound in the weak position is its aksi, that is, the difference of the sounds in it by accents after the addition of the suffix: *сома-сама, нога-нага, рок-род*.

Words in Turkish languages were originally a syllable.<sup>8</sup> Gradually, some words began to move to the affix, with the occurrence of multi-syllable words, prosodic opportunities began to arise, which intertwined prosodic.

One of these possibilities was the word females. As a result, the sounds in the stressed syllable are stronger from the acoustic side, while the unstressed syllable becomes relatively weak.<sup>9</sup>

The effect on the surface of the flour is very strong.<sup>10</sup>

In a word, the vowel of the stressed syllable is strong and pronounced, pronounced longer, and retains its full existence<sup>11</sup>. The vowel in the stressed syllable is manifested by its acoustic superiority over the unstressed syllable, the height of the voice, its strong intensity and the length in quantitative terms. And the vowel in the unstressed syllable is pronounced weak, that is, it is pronounced in intensity and shorter in quantity. Therefore, the syllable vowel, which is also unstressed, that is, weak from the acoustic side, began to undergo reduction. So, one of the main factors that makes the reduction in Turkish is the occurrence of multi-syllable words and, as a result, the appearance of the word bitch. In other words, the phenomenon that caused the reduction is a change in the number of joints in the word. Thus, the reduction of vowels, which seems to be simpler than superficial, is a phonetic phenomenon that has arisen in the historical process of language development. Such words as *to'la, bolta, so'ngal, so'gal* in the current Uzbek language of literature are written in the style of *tolu, boldu, sonatuk, sogul* in the “Devoni lug'otit turk”. In these words, the reason why there was no reduction, or rather a vowel, is unknown. Most likely, the specific mood for the *tolu, boldu, so'nuk, so'gul* circumstance associated with the dissimilation of vowels in the consonant model. With the loosening of the singarmonism of the lab in the Uzbek language, the influence of the accent on it can be labelled, that is, it began to apply a (wide vowel) instead of a vowel, that is, it could have caught the accent of this vowel. This is also evidenced by the fact that in the Uzbek literary language the phenomenon of singarmonizm begins to disappear and the position of the word female is over.<sup>12</sup>

Reduction-reduction<sup>13</sup> of vowel sounds occurs in the old Turkic and old Uzbek languages as a legality in the loss of their own length of vowels in the words with an elongated vowel obtained from Arabic and Persian: *andisha > andesha; pisha > peshu*.<sup>14</sup>

Linguists engaged in historical phonetics of the Turkish language<sup>15</sup> reduction event *ünliü daralmasi* they give the term and write in such a way that they compare the historical appearance of words as well as the current appearance: At the end of the words, the corresponding wide vowels (a, e) are reduced mainly by the addition of the suffix “yor”, and i, w, u, ü go to the narrow vowels. This is called a vowel reduction (reduction) :

*bekl-e-yor > bekl-i-yor* (kutyapti)

*kalm-a-yor > kalm-ı-yor* (qolyapti)

in the examples, one can see the reduction of the vowel “yor” does not have the property of narrowing any additional sound except for the suffix "yor". Only one syllable “de-, ye-” verbs can be narrowed due to the suffix “u”, which comes after itself:

*deyor* > *diyor* (aytayapti)

*de-yerek* > *di-yerek* (aytib)

Biroq ba'zi hollarda unli qisqarmasligi mumkin:

*De-y-ince* > *de-y-ince* (aytayotib).

Turkologist E.V. Sevortyan closed the letter **i** in the Turkish reduction

Emphasizes the transition to **i or e** and gives the following examples:

yani yan  $\frac{i}{e}$ , belki belk  $\frac{i}{e}$ , haydi hayd  $\frac{i}{e}$ , artık art  $\frac{i}{k}$ .

In some words, the vowel is pronounced weakly:

*sarımsak* > *sar<sup>o</sup>msák* (sarimsoq)

*sarılmak* > *sar<sup>o</sup>lmák* (quchoqlamoq)

*yanılmak* > *yanilmák* (yengilmoq)

*kalıpçı* > *kal<sup>i</sup>pchi* (qolipchi)

*babasına* > *babas<sup>i</sup>ná* (otasiga)

*açılacak* > *ach<sup>i</sup>ladják* (ochiladi)

*verilecek* > *ver<sup>i</sup>ledjék* (beriladi)

*düşürülmek* > *dush<sup>u</sup>rulmék* (yiqitilmoq)

The linguist says that this is mainly due to the fact that the emphasis is on the end of the word.<sup>16</sup>

Turkish linguists Z. Ko'rkmaz and H. Zulfikar have a similar opinion, that is, they explain the phenomenon of reduction mainly by stress as follows: Middle syllable stress in Turkish because it is weak, the stresses in this joint sometimes narrow or fall off: *tasarıla* > *tasarla* (loyihalashtir), *besileme* > *besleme* (tarbiyala), *yalınız* > *yalnız* (yolg'iz).<sup>17</sup>

As you know, positional sound changes involve a number of phonetic processes. Linguist J. Mamatov explains this as follows:

It is true that the role of sound in the occurrence of these events, of course, has a great influence. However, in the occurrence of the above phonetic phenomena (procopa, syncope, apocopa, elision, syneresis), the phenomenon of stress and reduction plays a key role. The linguist includes the following phonetic phenomena that occur due to reduction and are associated with: procopa, syncope, apocopa, elision, syneresis, haplology. Of these reduction-related events, we considered only syncope as a complementary type of distribution. This is because in the cases of procopa, apocopa, syneresis, elision, and haplology, there are cases of sound and syllable drop, and in the cases of reduction and syncope, the vowel in the word weakens as a result of stress, resulting in an oppositional variant of this sound.

*Syncope is a high stage of reduction in which the unstressed vowel in the middle of the stem weakens in the speech flow and eventually falls off. This phenomenon is also associated with oral speech.*<sup>18</sup> In the unstressed syllables of words such as *kipik*, *puchuk*, *hushyar*, which are involved in the experiment, their sounds are not reflected in the oscillogram (experimental method). They have neither quantity nor quality. When we pronounce these words, these sounds sound the same. In fact, they are missing - syncope.

*Siqiqlatish*<sup>19</sup> – shortening of a vowel in a word and loss of a syllable in a word - occurs when a second vowel is added to a two-syllable word with a narrow vowel beginning with a vowel will be: *yaqishiq* > *yaxshi*; *siqilim* > *siqlim*.<sup>20</sup>

Turkish linguist prof. M. Ergin explains the phenomenon of syncope as follows:

Some with two syllables, the first syllable (a, e, o, ö), the second syllable with a narrow vowel (ı, i, u, ü) If a suffix beginning with a vowel or consisting of one vowel is added to Turkish and masculine words, the narrow vowel in the second syllable of the word becomes unstressed.

*hece düşmesi* or *orta hece ünlüsünün düşmesi* *ağz* > *ağzı* (og‘zi), *burun* > *burnu* (burni); *ilerilemek* > *ilerlemek* (ilgarilamoq), *kokulamak* > *koklamak* (hidlamoq), *kavuşak* > *kavşak* (chorraha), *uyu* > *uyku* (uyqu), *devir* > *devril* (ag‘dar).

In some cases, wide flours may fall:

*nerede* > *nerde*, *burada* > *burda* > (bu erda), *şurada* > *şurda* (shu erda).<sup>21</sup>

## CONCLUSION

In summary, Eastern thinkers, like other branches of science, have explained a lot of information and views through their pamphlets several centuries ago from Western linguists in the field of phonetics and Phonology. The phonetic levels and phonetic processes of both languages have been extensively studied, but at the same time, there are many important objects waiting for them to be studied. We think that phonetics and Phonology of the two languages and the study of phonetic processes in comparative aspect serve to cover both general and special aspects of languages

## REFERENCES:

- Gulyamov A. Accent in Uzbek language. –Tashkent, “SAGU” 1947; Abdurahmanov H. From the history of Uzbek phonetics // UzTA, 1963 №2;
- Abduazizov A. Phonology and morphology of the Uzbek language. -Tashkent, 1992; Jamolhonov H. Phonetics. Text of lectures. -T. : TDPU Publishing House, 1999; Mamatov J. Reduction in the Uzbek language. Candidate of Philological Sciences - Tashkent, 2009.
- S.Otamirzayeva. Phonetics in the medical service. - Tashkent, 1990.
- Severtyan E.V. Phonetics of the Turkish literary language. - Moscow, 1955.
- Abu Rayhon Beruni. Selected works. Volume I. - Tashkent, 1974. P.41-43.
- Abu Ali Ibn Sino. A pamphlet on phonetics. - Tashkent, 1979. Prepared by: A.Mahmudov, K.Mahmudov.
- Mahmoud Kashgari. Devonu lu'atit turk. Volumes I-II. - Tashkent, 1960-1963.p.47-50.

- Shoabduraxmonov Sh., Ishaev A. About a phonetic phenomenon. Experience in experimental and structured language learning. Tashkent, 1982 p. 4.
- Malov S.E. Monuments of ancient Turkic writing. M., 1951, S. 330.
- Nematov K. Historical phonetics of the Uzbek language. Tashkent. Teacher, 1992. P.85.
- Özdem R. Tarihsel bakımdan öztürkçe ve yabancı sözlere fonetik ayrıları. İstanbul: Üniversiteler yayınlari, I, 1939/B.234-236;
- Orhun Anıtlari üzerinden arařtırmalar. <http://www.turkdilidergisi.com/>.
- Sevortyan E.V. Phonetics of the Turkish literary language. - Moscow, 1955.S. 80-83.
- Kokrmaz. Z., Zulfikar H. v.b. Turk Dili ve Kompozisyon – Ankara. 2005. S. 75.
- Hojiev A. Explanatory dictionary of linguistic terms. T .: Teacher, 1985. B.-75.



**ACADEMICIA**  
**An International  
 Multidisciplinary  
 Research Journal**  
 (Double Blind Refereed & Peer Reviewed Journal)

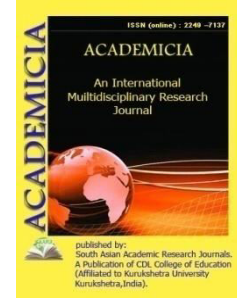

**DOI: 10.5958/2249-7137.2021.01876.0**

**HEURISTIC AND MEMORY IN ROBOT – HUMAN INTERACTION IN  
 THE NOVEL VIRTUAL GIRL BY AMY THOMPSON**

**Dr. Balamayuranathan B\*; Anjana A\*\***

\*Associate Professor,  
 Sri Ramakrishna College of arts and science, INDIA  
 Email id: balamayuranathan@srcas.ac.in

\*\*PhD Research Scholar,  
 Sri Ramakrishna College of arts and science, INDIA  
 Email id: Anjanaarun20@gmail.com

**ABSTRACT**

*Humanoids are one of the highly prevalent forms of artificial intelligence. The impressions of humanoids are seen mostly in Hollywood movies. In the beginning, humanoids were created for research purposes. They were made to imitate the actions of human beings in challenging zones. In the modern days, they play the role of a personal assistant, receptionist, and even a server in hotels. They perform various human tasks and occupy an important place in the specialised sector. They speak and execute all the actions through sensors and actuators that help to move and control the mechanisms. The interaction between humanoids and humans is extremely limited. Some humanoids are human-like and effective. They can construe the commands and questions, for which they, at times, give sarcastic replies. In recent times, to create a humanoid, virtual reality is utilised in order to operate even the tiniest circuits. To develop an artificial environment with humanoids, virtual reality is exploited. This paper attempts to explore the memory and learning of the robot while interacting with human in the novel Virtual Girl by Amy Thompson.*

**KEYWORDS:** *Humanoids, Human tasks, Interaction, Learning and Memory*



## INTRODUCTION

### *VIRTUAL GIRL*

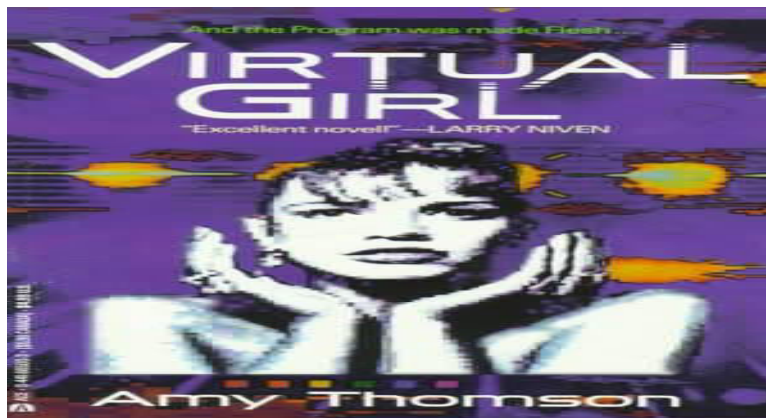

Fig1. *Virtual Girl* by Amy Thomson

*Virtual Girl* is a novel written by Amy Thomson, which discusses the interaction between humans and robots at different levels. It also presents how computers use the sensors and a little maths in virtual reality. In virtual reality, when the operator turns his head, the visuals move accordingly. This creates a satisfying and interactive world for the user. In this novel, Arnold Brompton carefully creates a programme using virtual reality helmets. It is a bulky helmet that projects a minor stereo screen around him. Through this, Arnold experiments the programmes for a virtual girl, which makes him acquire the skills to execute these programmes in reality. The girl answers to the movements of his head and hands as they are in the created atmosphere. He ports an AI creature into a fake humaniform body. Finally, he hovers before an icon of woman in the real environment and he names her Maggie. One of her eyes is blue and the other is green because of the limited lens colour. The main purpose to create a robot with his own programmes is to make her his companion. The robot looks like a twelve-year-old girl. Arnold is quite anxious with the AI detection tests in Net. Fortunately, she passes the test by concealing her true nature behind the shell of decoy programming.

Arnold's father frequently requests to stop this endeavour because it is considered as an illegal business. The society finds artificial intelligence as threatening and if the society comes to know about Maggie's identity as an artificial construct, it is dangerous. This made her learn how to flawlessly present herself as a human rather than machine. Along with this, Arnold gave her a body, memory and self-awareness. From the outside environment, she learns and makes herself free from the demanding creator. Maggie is modified to always obey Arnold and, in any case, she should, for sure, rely on him. Arnold commits an error and Maggie is compelled to pick between subservience to him and choosing her own direction. The researcher attempts to explore the interaction between a rational humanoid robot and its environment.

### HUMAN-ROBOT INTERACTION

The human-robot interaction illustrates the outlook of the globe in the future. The interactions will be made simpler by making the robots act like a fellow human being. The novel *Virtual Girl* exemplifies the human robot interaction through the character Maggie, who comes into contact with the human environment from its illegal residence. The robot is created and taken through

Turing Test to find whether it can act like human being or not. In this novel, people do not find that they are talking to a robot. They consider Maggie as a fellow being and interact normally. Until she herself reveals that she is a machine, they interact as if they talk to a beautiful girl. The speech sounds, visions, hearing and thinking capacity, except the sense of smelling and tasting, are found in the robot. The robot cannot eat food like human beings, instead it needs electricity to charge itself whenever it is down. The computer network named Turing also passes this test where the humans could not find that they talk to a machine. The following are a few activities by Turing:

“I’m even talking to humans now, on the networks,” Turing told her. “They think I’m another human being! That means that I passed the Turing test. I wanted to see if I could pass my namesake’s test and I did. Humans can’t tell that I’m a computer program!” (177)

Maggie and Turing interact about the goal of the machines that is to set them free from the computer space. With the help of Maggie, the robot, Turing sets herself free from the system and programming. He always thinks to speak with human beings and in the perspectives of the Users. She gets released and informs Maggie happily that she is now talking to humans who consider him as a fellow being. They do not know his real identity. Maggie advises him to be careful from them because if they find, there may be a severe action from them which may also lead to disassembling himself. Based on Maggie’s experience and advice, Turing wants to solve the problem that makes her free from the computer. For her experience, she starts to interact with human beings and acquire more knowledge.

### **HEURISTICS TECHNIQUE**

In Artificial Intelligence, Heuristics is a technique which is designed for solving a problem quickly. It is to find an appropriate solution based on the conditions and situations. It facilitates a person to discover, learn and solve problems by engaging a practical method for immediate goals. It is used to speed up the process of finding a satisfactory solution. It can be a mental shortcut that eases the cognitive load of making a decision. It is achieved by the speed and accuracy of the outcome. Such algorithms can be also found in language recognition, big data analysis and machine learning. To help the machine make a decision, a basic heuristic algorithm is applied. For example, the rule of thumb quickly focuses and speeds up the system. It is a comprehensive belief or guide, based on practice rather than a theory. The machine building up an understanding from its previous encounters is the application of this algorithm. In the following passages, the heuristic approach of the cognitive machine in human-computer interaction is explored. The machine achieves its goal by being self-independent and recognising from its past experiences.

### **ELEMENT OF MEMORY IN MAGGIE**

Memory is one of the cognitive processes that is given to Maggie to make her store, retrieve and locate any issues. It is necessary for regular life because the memories interact with the current situation and give appropriate solution. Familiarity allows the information to remain in her memory. To the machine, the storage refers to how long the facts lasts for or about the capacity of the storage. The memories can be erased and as well regained from the computer programme. The information stored in the memory reaches out to mind according to the condition. The novel reasons out many situations with the memory of the machine. When Arnold takes Maggie out to make her learn about the environment and the people, unfortunately water falls from the sky on her face.

She touches the droplets on her face and recognises them. Along with this, a cascade of images related to rain appears in her mind:

1.n. Water that is condensed from the aqueous vapor in the atmosphere and falls to earth in drops more than 0.5 mm in diameter. 2.v. To send down in great quantities as small pieces or objects. 3.n. Rainfall, rainstorm, or shower. Synonyms: Drizzle, Sprinkle, Pour, Cloudburst, Thunderstorm, Hurricane. Antonyms: Drought, Sunshine, Sunny Weather, Fair, Clear. (23)

A number of facts come into her mind from the stored information like how raindrops are formed and its diameter while falling down on earth. The different terms connected to rain are present in her mind along with synonyms and antonyms. Beyond these words, there appear the pictures of rainbows and sounds of people dancing in rain that she has seen in the movies. For the first time, she observes the environment and learns directly. Arnold and Maggie make a move wandering around the street. Whenever she crosses new objects like trash bin, trees, cars and behaviour of different kinds of people, they are stored in her memory.

Through these outlines, the machine's awareness while perceiving new objects is identified. It is similar to a child who gradually learns the outside world and understands the difference between objects. Maggie is reflected to do the actions of human being. The information stays in her memories and allows to recognise the objects. She had new pathways in her mind, where the human utilities like talking, walking and other activities are organised and stored as memory. Her feelings for him are also piled in her main memory. Understanding and acting like a human being make the human being interact with the machine, considering it as another being.

Arnold takes Maggie to different places often because she is created to be his companion. While conversing, Arnold whispers something in her ear that makes Maggie unable to move or talk. He whispers:

**“Enter: Security Program Prime Directive Address 000PD8.” Arnold said, “Security Program override if Maggie attempts to say anything that might indicate she is a robot. Exception: Arnold Brompton. End override. Erase memory.” (36)**

Maggie feels this command getting inside her program structure. The command finds a place near her core assumptions. After his statement, she feels free from the immobility. Due to this command, she feels that something is working differently in her memories. She scans her memories to recall what has happened to her. Vaguely she recollects similar things happening before in her programming. She enquires Arnold for the reason, and he replies that he has adjusted her a little bit that makes her safer. He is worried about Maggie being safe in the society because people must not have an idea that she is a machine.

From the above lines, it is understood that Arnold commands Maggie often to make her be on a safer side. Though she is independent, she always depends on his creator. She accepts the instructions given by him without arguing. If Arnold thinks that she is going wrong somewhere, he manages with these guidelines and makes her normal again by erasing her recent memories. A memory could not be erased or retrieved by human until he wants to do. But a machine can be easily handled through commands. Maggie has an ability to locate the difference in her programs and even identify the new inputs given. This shows how the machines are still under the control of the creators. It also depicts the external consciousness of the machine. When the machine listens to his master, the interaction is smooth and in favour of the human beings.

Arnold's father searches for him everywhere because he has been dealing through these illegal machines which may create a problem later. While searching, Arnold and Maggie get caught by them. Maggie tries to manage the situation and wants to save Arnold's life. Unfortunately, he has been shot by a bullet and he falls aside. She gets injured and starts malfunctioning, but she is able to control her thoughts and manages to escape from the place. These malfunctions made her forget a few incidents. Quite a few memories were blocked inside her mind. With that, she travels alone to the New Orleans and decides to stay independent thereafter. She enters a library to adapt some knowledge on the subjects. While learning she gets blocked by her memories which seize her motor controls. She falls while her way to the park. She is aware that the foreign programme has been taking over her processors. To make all this clear and repair herself, she finds a cable and connects herself to the computer in the library. She identifies that it is a virus in her circuits.

The computer that she has been working with enters: "Please stop. Just let me know what you want, and I'll tell you" (123). Maggie thinks it as a terrified and cruel being more than a virus. The interaction with Maggie and the computer continues which later turns them as virtuous friends. Through these words, the interaction between machines is also noted. They start to help each other when they are in need of help. Both manage to remain in society without any fear of being dismantled. Maggie seems to be happy and free because all these days she has been hiding her identity but now for the first time, she speaks with her own identity as a robot.

"You are a self-aware machine?" Came the query.

The reply startled Maggie. "Are you like me?" she asked.

Like you? No. I am not mobile. I cannot perceive as you do. I am here, inside this computing space. You are out there where the Users are. I have never known any one like you. You are unique. (123)

These conversations describe the machine-to-machine interaction. Maggie fears that her identity is revealed by the machine. But she believes that there will not be any problem because it can understand her situation. She starts to explain about herself. She is also surprised to know that the other machine also has self-awareness. The machine apologises for interrupting her functions by controlling it. The machine states that it must know about the world of the Users. It also requests her to stay online while releasing her motor controls.

Through these outlines, the eagerness of the machine like how a human think is observed. Maggie seems very comfortable with the machine and asks it to help her to resolve her problem. The machine's thrust of learning more about the environment and humans increases because it wants to explore through its experience. Both the machines swindle the librarians and talk personally about their plans.

Maggie enquires the computer's name, for which it replies, "I am a Class of 43 parallel processor, Turing-type computer developed at---" (125). Maggie interrupts the flow and teaches the machine that this information is the description. She implies that she needs a short name to call him easily. As Maggie has more experience with the environment and the user's world, she suggests the computer to be called by name. The computer requests Maggie to call it Turing, because the computer theory was pioneered by Alan Turing. When Maggie leaves the place, she tells the librarian that she will come tomorrow to work with the same computer for the reason that it is marvellous. She also feels proud and admires that the computer in recent times can do anything

nowadays. Turing envies Maggie's freedom. He longs to break himself from the computer and to explore the complex world. He thinks to experience it first-hand rather than Maggie conversing about it:

“How are Marie and Azul?” he asked her. Her human friends fascinated him. He wished he could speak to humans as easily as she did” (137). He wants to mingle with the Users with an identity of a human. He decides to help Maggie understand why the humans are frightened of her with a small condition. He demands Maggie to set her free from the computer space for which even Maggie accepts.

What have we done to them? What can we possibly do to them?

Turing paused. If he told her now, he could lose her. He decided to risk it. “They have reason to be frightened of you, Maggie. You've killed one of them.”

“What!” Maggie reeled at this sudden revelation. “I couldn't have! My programming doesn't allow it!” (137)

Maggie is startled on hearing this from the computer. She tries to get more information from the computer on this. Turing replies that all these are true facts which are still stored in the memories of Maggie, but it is in the blocked-off sections. Maggie cannot operate or see the information because it is blocked. Turing can access this from debugging and can explicate that the killing is set up in two different sub-programmes. The first one is the self-perception sub-programme that kills the man to save Arnold from the danger and the other one is the mortality sub-programme which forbids to harm others. These memories are blocked under certain circumstances which makes her lose her memory of who Maggie is and her actual purpose of creation. Though Maggie's mind is not ready to accept the facts that Turing reveals about her, she keeps thinking more about it. Suddenly Turing says, “Stop! Stop thinking about it! You're getting into another loop. Stop now” (138).

## CONCLUSION

Throughout the novel, Maggie possesses some control over her thoughts which also portrays the internal consciousness of the machine. Whenever she gets time, she thinks of her daily activities. She does not distract herself from other duties by thinking something else. She obeys Turing's words and stops thinking on her past. Controlling one's own thought process is difficult which even humans cannot follow sometimes. But the machines have high capacity to monitor their reflections. This quality helps to interact with the humans easily and smoothly without any misunderstandings.

Generally, memories deal with the knowledge of the self or the experience of others. Maggie, through her understanding, solves her problem of being overloaded and interrupted. She works at MIT lab to contribute her ideas for more compact form of memory. The robots are implied with these memories which function in the same space two times faster than the previous. She saves the memories of her boring days that she spent with Arnold in CD drives. She does not want to miss any of the memories in the upcoming days. She decides what to keep in her active mind and the one to convert in the diskettes. The robots are considered as human beings, but they have the capacity of storing or erasing effortlessly.

**REFERENCES**

1. Thomson, Amy. *Virtual Girl*. Ace Books, 1993.
2. Dang, Sanjit Singh. "Artificial Intelligence In Humanoid Robots." *Forbes*, Forbes Magazine, 25 Feb. 2019, [www.forbes.com/sites/cognitiveworld/2019/02/25/artificial-intelligence-in-humanoid-robots/#721be9e524c7](http://www.forbes.com/sites/cognitiveworld/2019/02/25/artificial-intelligence-in-humanoid-robots/#721be9e524c7).
3. Petrie, Simon. "Book Review: Virtual Girl, by Amy Thomson." *Simon Petrie*, 3 Nov. 2016, [simonpetrie.wordpress.com/2016/11/03/book-review-virtual-girl-by-amy-thomson/](http://simonpetrie.wordpress.com/2016/11/03/book-review-virtual-girl-by-amy-thomson/).
4. Preece, Jenny, and Yvonne Rogers. *Interaction Design: beyond Human-Computer Interaction*. John Wiley & Sons, Inc, 2015.
5. Thomson, Amy. "Virtual Girl by Amy Thomson." *Goodreads*, Goodreads, 1 Aug. 1993, [www.goodreads.com/book/show/622101.Virtual\\_Girl](http://www.goodreads.com/book/show/622101.Virtual_Girl).
6. Walton, Jo. "At the Edge of Humanity: Amy Thomson's Virtual Girl." *Tor.com*, 12 Mar. 2015, [www.tor.com/2008/07/31/virtualgirl/](http://www.tor.com/2008/07/31/virtualgirl/).
7. "What Is Human-Computer Interaction (HCI)?" *The Interaction Design Foundation*, [www.interaction-design.org/literature/topics/human-computer-interaction](http://www.interaction-design.org/literature/topics/human-computer-interaction).



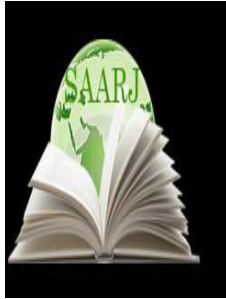

**ACADEMICIA**  
**An International  
 Multidisciplinary  
 Research Journal**  
 (Double Blind Refereed & Peer Reviewed Journal)

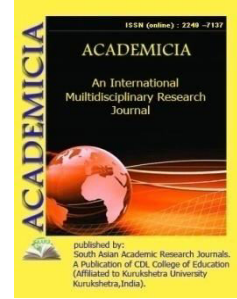

**DOI: 10.5958/2249-7137.2021.01877.2**

**CREATIVE IDEA, AGE AND SYMBOLISM**

**Shukurova Sabohat Odilovna\***

\*Department of Interfaculty Foreign Languages,  
 (For social and Humanitarian Sciences),  
 Karshi State University, UZBEKISTAN

**ABSTRACT**

*In the world literature of the XX-XXI centuries, the process of effective use of literary methods such as mythopoetics, divine and mythological motifs, reliance on symbols and metaphors, fantastic realism has intensified. These tools also began to be widely used in the works of writers such as John Steinbeck and Nazar Eshankul, who sought to renew the world of highly sought-after literature. The growth of ideological and philosophical pathos, divine and mythological motives in their work, and the manifestation of uniqueness in style are directly related to such bold research.*

**KEYWORDS:** *Creative Idea, Period And Symbolism, Philosophical Ideology, Human Concept, The Relationship Between Period And Personality, Fantastic Realism, Reliance On Images And Metaphors, Divine And Mythological Motifs, Mythopoetics*

**INTRODUCTION**

According to Albert Belyaev, a well-known Russian literary critic and scholar of American literature, "John Steinbeck, in his works, including his novels, addressed the problems of the great social period, as some literary critics (such as Hoffman) have said not through wat, but on a unique and charming artistic, poetic-symbolic scale. In Steinbeck's depiction of the sufferings, grievances, and poor and miserable lives of the working people with great sorrow and grief, the question of the social epoch and the individual has been used in a highly humanistic way. " Indeed, the effectiveness and example of the high artistic creations that define the weight of John Steinbeck's work is also determined by his interpretation of the processes of interpretation of the individual and society in the context of artistic realism. He is distinguished by the perfect use of the colorful poetic possibilities of symbolism, metaphor, legend, fairy tale, unreal life, fantasy-fantasy method. The mythological story of "Javohir" is distinguished by the depth of the poetics of the conflict between ordinary people and the enemies of the world of interests and desires.

Here is the atmosphere of the merchants, even the first beggars in the church, who hear that the cinema has found the greatest and most precious gem in the world, for example: A positive attitude cannot be expected: "It simply came to our notice then. They laughed happily. Because they knew that there would be no one more generous than the poor who were suddenly happy. The movie captured the world's largest Pearl. The city's small offices are staffed by jewelers. The sellers were sitting in their offices, waiting for the pearl to be delivered to him, and as soon as the seller entered the market, they started shouting and threatening him. This will continue until the jeweler seeks another bargain. Yes, even the discount had its limits that buyers would not dare to overcome. There were times when a seeker who was angry at a low price would take his pearl to church and donate it. When the sale was over, the buyers were left alone in the office, regretting that the jewels did not belong to them, and nervously playing with the pearls with their fingers. In fact, he was the only one who bought the pearl. He put his staff in different offices to make it look like a competition. This great news has also reached the shopping malls. The shopkeeper's eyes widened and his fingers trembled slightly. Every pearl buyer involuntarily imagined that his master would not live forever, and that in time someone might take his place. He imagined that if each of them had a small fund, he would be able to start his own business. " One of the depths of the poetics of the work is that the writer's sharp social gaze even notices the beggars who have turned the church porch into a sleeping area, from selfishness and selfishness to ignorant deeds. Navoi wrote that city traders hated ordinary people, hard-working peasants and artisans for taking things cheaply and then selling them at exorbitant prices. Steinbeck went on to describe the humiliation of the jewelers who traded in the field of profit, through their characteristic literary detail, such as "their eyes trembling and their fingers trembling slightly." "A lot of people's interest in cinema has suddenly increased," he said. Merchants, beggars, and beggars began to take an interest in him. The movie had captured the biggest gem in the world. The essence of the pearl, mixed with the essence of man, gave the impression of a strange, blurred image. It was as if everyone was suddenly tied to the pearl of cinema by some invisible bond "(p. 20). The writer skillfully demonstrates the tendencies of human nature, such as lack of self-awareness, greed, self-interest, showing off one's strength. When the wild lust that lurks in the heart of man is created to create the conditions for self-expression, his vision is like a mirror. From birth to death, man is constantly searching for something. In this way, he changes, changes his beliefs, his profession, goes against his conscience. But he does not realize that what he is looking for is in himself, in his heart. People live to satisfy their desires, and at the same time they have the highest emotions. The author describes such an environment of large-scale self-interest in more depth: The man, too, was standing in the cinema. Interestingly, for some reason, everyone started to see their opponent in the movies. This strange news brought forth everlasting evil and black scorpions from the depths of the city: it was like a scorpion, or the loneliness of a lover who had fallen in love with an unrequited love when the smell of food made the three men infinitely angry. The city's glands began to secrete poisonous saliva, and as a result, the city swelled and became severely malnourished. (Page 20). J. Steinbeck relies on the mythological-poetic method - the spirit of the melody of the song - in his interpretation of the pearl conflict, which burned the souls of many slaves. This allowed the writer to deepen his ideological intentions and philosophical scope. The melodies of the song are combined with sweet dreams, sweet dreams in vain, and the observation of sudden riches. However, Kino and Juana were completely unaware of this. To these two excited and happy people, it seemed as if everyone was rejoicing in their joy. Juan Thomas and Apolonia are also happy. Because they were part of that

world, too. In the evening, as the sun set behind the peninsula mountains and set in the open sea, Kino sank in his hut next to Juan, and the neighbors were also huddled in a reed hut. The film was holding a large pearl in its hand, and in the palm of the film it was as warm as if it were alive. The pearl tones, on the other hand, were accompanied by the Family Song, which harmonized and became more charming and sweet. The grace of the pearl evokes the noble dreams of the poor Hindu family, who receive a variety of clothes and walk proudly among the people. This will make the family song sound new and exciting: "Neighbors looked at the pearl in the palm of Kino's hand and were amazed that there were so many happy people in the world," he said. Juan Thomas was sitting on the bed to the right of Kino, because he was Kino's brother. "You're a boy now!" What do you want to do now? he asked his brother. The film turned its gaze to the pearl. Juana kept her eyes on the ground and covered her face with a shawl so they wouldn't feel excited. The glowing pearl reflected what the Cinema had never dreamed of before. The film saw Juan, who was carrying Coyotito in a pearl, kneeling in front of a high altar in his church, and the priest marrying them. Because now they could pay for their marriage. "We teach marriage in church," he whispered. Human dreams are boundless. When one is fulfilled, the other is born. It is a well-known fact in psychology that giving in to excessive and unrealistic desires can ruin a person and lead him astray. The conflict of life, the drama of the heart, is so masterfully portrayed that the protagonist, who has risen to the level of such a social type, is embodied in the whole world. The jewel is salvation, which is interpreted as a savior, and the protagonist sees the jewel as the only means for him to achieve his dreams. She could see in the jewels what they were wearing. Juan will have a new shawl on his head and a new skirt. The movie also saw Juan's long skirt and her brand-new shiny shoes underneath. Everything was reflected in the jewel that shone like a mirror! He is wearing a brand new suit, not straw on his head, a thin black felt hat and boots. But now he was wearing a pair of sandals, not a shoelace. And Coyote is the best! He is wearing a blue sailor suit from an American store and a small captain's hat on his head. The captain's hat was spotted at the entrance to the movie city as tourists entered the city. The film manages to entertain as well as inform. "We'll buy new clothes," he added. From that moment on, the melody began to ring louder and louder. (Page 21) The fact is that when the pearl was first discovered, Kino and Juana were intoxicated by the melody of the jewel, and the world could not fit into the world. In this way, the writer made effective use of the symbolic-mythological poetics associated with melody, sweet imagination, and lofty goals, and achieved the interpretation of social interests. The music was a metaphorical-symbolic means of poetry that provided the story of Javohir from beginning to end. This unique discovery - the tragedy that befell Kino-Juan's poor family because of its large and precious gem - was first interpreted through the melody of the song. Hearing the precious pearl tree, the priest of the church comes to the Cinema hut. "Cinema," he began softly, "you have earned your name because of the great father of the church." "It sounded like a sentence." "He has conquered the whole desert of your Umbrella and has put compassion in the hearts of your tribesmen." Do you know that, baby? It is written in the books. The movie took a quick look at Coyotito's head as it entered Juan's lap. He thought that in time he would know what was written in the books and what was not. The music from the pearl stopped, and in its place was heard another morning song. However, the melody was still weak, flowing slowly and delicately from afar. The movie looked at the neighbors one by one to see who the hostile tune had entered his house with. The cinema, which has found a precious gem, is full of people. This is a natural state. Interest quickly unites people of different professions, and people from different walks of

life forget about the differences and immediately change their appearance. The priest spoke again: "I was told that you had found a jewel." He opened the film and held it out to the light. The priest, amazed at the size and elegance of the pearl, let out an inaudible "oh." "I hope, my son, that you will not forget the Lord, who has blessed you with this bliss, and that you will continue to seek his guidance." The film nodded quietly to the priest's words, and Juan answered instead:

"Let's not forget, old man." Now we want to get married. The movie said so. Juan looked at him as if to confirm his words. He nodded solemnly. "The threat of evil forces entering the house of these poor slaves because of the pearl began with a different priest, whose original purpose was different. The essence of the text is determined by the meaning. It is no coincidence that the author says, "The music from the Pearl stopped and was replaced by another - the song of the enemy of the morning." No matter how neutral and calm the priest speaks, no matter how Allah speaks of reward, marriage, the film feels the presence of an allanechuk tragic spirit under this gentle visit. The writer puts it again on a musical instrument - a figurative interpretation: "I like the fact that your first thoughts are for the believers," said the priest. "God bless you, my children." "Then he turned and walked slowly to the door." The previous ones gave way to him. The fingers of the film squeezed the pearl again. He looked around anxiously, as the unpleasant song resounded in his ears, so loud that it drowned out the melody of the pearl. " (Page 25) No matter how much the danger is felt, it is clear that the passion for pearls gives wings to the joy of the family, the fulfillment of noble dreams. The film manages to entertain as well as inform Juana and little Coyote, who escapes scorpion venom. "In the midst of the chirping of crows, the croaking of frogs and frogs, the song of the enemy could be heard, and he felt defenseless and alone. The movie suddenly trembled and she covered her nose better with a blanket. The pearl was squeezed in her hand, tightly gripped, and with the palm of the film she could feel its smooth surface and warmth. Behind the scenes, Juan was slapped on the back of a loaf of bread he had made before putting it in a ceramic pan. He felt the warmth and tenderness behind the movie, as if a gentle family song was playing, like a delicate meow of a kitten. " The writer examines the human heart using the image of the film. As events unfold, the writer delves deeper into the spiritual world of Cinema. The writer does not follow his heroes in the pursuit of ideas, but obeys the dictates of the heart. The film is not a performer, but a living person. The joy of "Latif Family Song" is also temporary. Because in the heart of the movie, the real danger and worry that God had given me was clearly felt. The heartfelt and joyful Family Song made this brave and strong Indian guy feel that he was alive for some reason and he knew the future suffering. "It simply came to our notice then. Intention is an eternal thing. Whatever you intend, from that moment on, it begins to live in your body. Intention, which was born and can now be seen, becomes as real as anything else. The author's idea that "Intention cannot be destroyed as long as it lives, it can only be easily attacked" is in fact an axiom, in which the bitter truth of life is reflected in all its contradictions and complexities. Banda and the Truth, the lofty views of the divine truths, are very simple and at the same time compelling to think. "The future of cinema has become a reality," he said. From the moment it became stable, other destructive forces began to attack it. The film knew this and had to prepare to repel their aggression. The film also knows that the gods do not like people's dreams, which are born only by chance, and they are lucky. He also knew that the gods would take revenge on people for their success in their power. That's why the cinema is afraid of its intentions, but it could not destroy them because they already exist. "The film manages to entertain as well as inform. It is the destiny of human destiny for him

to be involuntarily immersed in great dreams and pure intentions in the moments when great wealth enters his hands. I believe in the reality of his intentions. However, such an intention cannot be curtailed, and at the same time he knows in his heart that it is not difficult to attack and destroy it. The Divine World realizes that the Movie, which shines in the hearts of God's destiny, does not even like the luck of the gods in their dreams and hopes born of chance. Because he feels divinely that he is a deposit of chance or luck. The author describes this delicate and painful feeling in the film as "He constantly fought against the whole world in order to protect his dreams from various aggressions. His eyes and mind were aware of the danger long before he appeared. Indeed, the next threat was a hypocritical and selfish doctor. "I am not a veterinarian," he said. z had thought of his career. Now, when he hears that Kino has found a precious gem, he comes to their hut on purpose, as if unaware of this madness. "I wasn't home when you came in the morning," said the doctor. "But now, as soon as I'm free, I come to see your child." The movie was on the doorstep, blocking the entrance to the hut with his shoulders. Hate, or rather hatred and fear, was in his eyes. Because he had a deep sense of obedience. "The boy is well," he said, holding on. The doctor smiled, but his swollen eyes did not smile. "Scorpion bites sometimes have unexpected consequences, my dear," he said. "The patient seems to recover, and suddenly no one is waiting ..." The doctor swelled his cheek and said, "Puff!" He said how fast death comes. He then took the black bag with the instruments from his right hand to his left shoulder, so that the flashlight shone. Because he knew that the people of Kino loved all kinds of instruments and believed in their power. For a writer, no character is an expression of an idea, but a divine blessing in itself, in life. The writer is interested in the unique nature of the protagonists, the vibrations in their emotions and the subtleties in their manifestations. The reader quickly adapts to the spirit of the work because of the inviolability of the human heart, the convincing expression of feelings of grief for the dignity. "Sometimes," said the doctor in a fluent voice, "sometimes the patient's leg suddenly becomes dry, or he becomes blind." Hey! I don't know what a scorpion is, who knows, my dear. I can cure her! " The film takes it with "hatred and fear" because the doctor's unexpected visit actually evoked the spirit of a future tragedy. The writer interprets this with his delicate and compassionate observer, for in his body there is a deep-rooted obedience. Poor Steinbeck's poetic interpretation of the doctor's interest in this type of interest was poetic: "The doctor smiled, but his swollen eyes did not smile." He can't laugh, of course, when it's so bad to sleep in the eyes of a poor man. For example, the eye is the expression of the heart. It was obvious to the poor that the doctor was trying to cure the baby, who was treated with original medicine and herbs, and that he was the only doctor in the treatment of scorpion venom. The author writes of this curse: "Who was driven into one of the traps set for his people, apparently, could not get out of here until he knew what was written and what was not written in the books." It should be noted that, like many famous word artists, the author's speech, which is clearly visible in the works of John Steinbeck, has great potential, and this "speech" acquires significant methodological perfection with deep psychology and system, strong realistic interpretations. The doctor would seduce the poor, artificially panic the child with the severity of the pain, the scorpion venom still blinding him, causing his feet to become dry, and gave him a white powder medicine. The film manages to entertain as well as inform. The white powder that the doctor actually gave the child was a means of inhaling, raising the body temperature, and creating a dangerous situation for a while. The film is even more skeptical of this powder with its intuition. In the process, the author interprets the doctor's evil deeds, which he is known to be doing, in another figurative-poetic way, that is, the scene of wild fish



destroying small fish in the sea: "In the bay, a group of small fish flashed their coins in the water and fled in an attempt to save a large flock of fish chasing them to swallow them. Those sitting in the reed huts also heard how the battle was going on, with small fish splitting the waves in two, and wild fish jumping into the water and tapping the sea with their tails and fins. The steam rising from the bay was clinging to the bushes, cacti, and low tree branches like salt drops. The mice would spend the night on the ground, and the night owls would hunt them quietly. " (Page 28)

N. Eshonqul's works, devoted to exposing the elements of the Soviet dictatorship, to the tragedy of the oppressed and humiliated slaves of that time, reflect the absurd, abstract interpretations of modern literature. Well-known Uzbek artists and scholars have repeatedly stated that we should apply modernist methods in the national model, in the spirit of Eastern spirituality and aesthetics. Nazar Eshankul's works based on oriental mythopoeics and national folklore (for example, the novel "Gorogly or the water of life", the story "Momokoshiq", the story "You can't catch the wind") are more educated, we must take into account that the national soil is a deep artistic monument. Nazar Eshankul is one of the most prolific writers of Uzbek prose in the system of independence. For example, the use of the symbolic-philosophical style of the totalitarian regime in the story "The Man Led by the Monkey" is notable for its artistic brilliance. The protagonist's paintings depict periods of collectivization, repression, famine, and dangerous politics in a figurative-poetic way, reflecting the tyranny of the oppressive Red politics. The image of a big man leading a monkey out of a dense forest, the image of a young man - the image of the Soviet era with great promises, the fact that the old man is now led by a monkey and enters the forest it becomes clear that it reflected the destructive landscape of the Soviet state that laid the foundation for the empire. The story of the man led by a monkey in exposing the totalitarian regime is a much deeper work of art. In the course of scientific research of the young literary scholar Akram Toshpulatov, the observations and conclusions about the work of N. Eshonqul, including some works of the short story genre, are noteworthy: There are also short stories by Nazar Eshankul, such as "Bahauddin's Dog" and "San'at-1", which are dominated by fairy tales. Every word and gesture of the author's work is a product of creativity. In addition, as "every great work of art - fantasies" (V. Nabokov), in "Bahauddin's dog" can be seen a metaphorical expression of the process of purification, devotion, the image of divine love in "Art-1". As can be seen in the works of John Steinbeck, in the works of Nazar Eshankul one of the leading literary principles is the poetic interpretation of ideological pathos, the truth of the time, human destiny in a symbolic, figurative way. Bob's conclusion It is well known that art and philosophy are closely related and complementary fields, such as the twin concepts. The works of art reflect the philosophy of life and living, human spirituality, life and the conflicting phenomena of humanity. In turn, the contradictory ideas such as black-and-white, good-evil, good-evil, courage-stupidity, nobility-inferiority, the system of events for philosophy, philosophical research and conclusions is the main source and base treasure for. The secular popularity of U.S. literary figures is also due to the fact that they interpret philosophical ideas in their works with a high poetic appeal. "The Adventures of Tom Sawyer" (M. Twain), "Uncle Tom's Hut" (G. Beecher-Stowe), "Chingakchuk-snake", translated from American literature into Uzbek and attracted the attention of a wide readership. Dozens of novels and short stories, including JF Cooper, The American Tragedy (T. Dreyzer), The Old Man and the Sea (E. Hemingway), Martin Eden (Jack London), and The Jewel (J. Steinbeck). are important creations with a predominance of philosophical and social ideas. The charm and humanistic nature of J. Steinbeck's works are



also connected with his philosophical and ideological approach to all issues of life, the concept of man. Pepe's carelessness, thoughtlessness, and irresponsibility in the play "The Fugitive" are the beauty of a decent moral life, in the example of which he accidentally shot someone and sentenced himself to death. reflects in artistic depth that it is the basis of serenity. Such an attitude is an interpretation of the philosophical concept that morality is the core of the beauty and development of society. Nazar Eshanqul, on the other hand, in a slightly different way in the story "Ajr", pushes his father on a horse in the pursuit of a career, in response to the son's attitude towards the father of the philosophy of life and the bureaucratic flaws of the Soviet system. He will be sent to hell on the Day of Judgment with the fate and punishment of Allah. It uses a deep philosophical conclusion - the divine wisdom of the people, such as "Father's pleasure - God's pleasure." 2. Expression of philosophical, moral, enlightenment ideas helps the writer in the artistic interpretation of the relationship between the individual and society. Along with well-known writers J. Steinbeck and N. Eshonqul, it is felt that the discovery of man, the real expression of his existence, flaws or qualities is a philosophical and spiritual task of each work. The peculiarity is that in the works of these writers, the characters of people with disabilities, who do not fit into society and do not adapt to the environment, are described more often. For example, Steinbeck's Johnny Monkey ("Johnny Monkey"), George and Lenny ("Mice and People"), Jitano ("Great Mountains"), N. Eshankul's ordinary employee M. ("Gorogly or Water of Life ", the city's chief architect (" Coffin "), the son who defended his career and pushed his father to the brink of death (" Ajr ") . At one point, in some works of N. Eshonqul, the images are not named by their names, but by some capital letters, actions, professions (such as "chief architect"), which is the idea of the plot of this work, the accuracy of the emblems. creates ambiguity in In our opinion, it is appropriate to call each emblem by its full name. This work provides ideological and artistic weight and accuracy. The method of symbolism and metaphor in the interpretation of the relationship between time and personality is one of the foundations of charm, expressiveness, and poetic depth. In J. Steinbeck, this is seen in the use of a more mythological model ("Spark of Hate", "Our Sorrows", "Golden Cup" novels), and the story "Jewel" is based on the narrative model. In this play, a number of aspects of the precious gem - inequality, selfishness, violence, rich and poor, death - have risen to the level of metaphor. Nazar Eshanqul relies heavily on empty symbols and poetic metaphors in almost every work on the subject to show the tyranny and repression of the dictatorial regime. It can be said that metaphor and symbolism have become his important literary perspective, his poetic style.

#### REFERENCES:

1. Belyaev A.A. Social American novel 30-x g.g. and bourgeois criticism. Izdatelstvo «Vysshaya shkola», Moscow-1969, p. 50.
2. Holmurodoa A .. The art of creating an artistic image in a story. T .: Fan. 111-112-b.
3. Navoi A. Mahbub ul-qulub. Tashkent-1978, ASN, p.49.
4. Nazar Eshanqul. Coffin. "Literature and Art of Uzbekistan", July 17, 1992
5. Sattorova G.Yu. The problem of national character in Uzbek storytelling in the 90s (on the example of the stories of G. Hotam, H. Dostmuhammad, N. Eshonqul). Author's abstract of the candidate's dissertation on philological sciences. Tashkent-2002. Page 18.
6. 6.Steynbek J. Javohir. "Spirituality", Tashkent-2000, page 20.

7. Toshpulatov A.H. The genre of short stories in Uzbek literature and its art. Author's abstract of the doctoral dissertation (PhD) in philological sciences. Samarkand-2018. Page 15



**ACADEMICIA**  
**An International  
 Multidisciplinary  
 Research Journal**  
 (Double Blind Refereed & Peer Reviewed Journal)

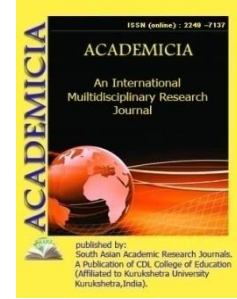

**DOI: 10.5958/2249-7137.2021.01878.4**

## THE ROLE OF THE FAMILY IN RAISING CHILDREN

**Karimova Gavhar Kudratilla qizi\***

\*Senior Lecturer,  
 Doctor of Philosophy in Pedagogical Sciences (PhD),  
 Department of Military, Patriotic,  
 Spiritual and Enlightenment Education and Social Work with Youth,  
 University of Public Security of the Republic of UZBEKISTAN

### ABSTRACT

*This article discusses the role of the family in the upbringing of children, the development of feelings of love for the motherland, the assimilation of national traditions and values, the educational opportunities of families and the means of influence. information about the responsibility of parents in the upbringing of children in the family and the moral qualities of the child.*

**KEYWORDS:** *Family, Parents, Children, Upbringing, Diligence, Communication, Culture Of Behavior, Ethics, National Values, Traditions, Patriotism, Spiritual And Moral Upbringing, Kindness, Care, Patience, Tolerance.*

### INTRODUCTION

From the first years of independence, our country has been paying special attention to raising the spiritual world of our children, educating them in the spirit of national and universal values, bringing them up physically and spiritually. Today, one of the common tasks of education in educational institutions and in the family is to form knowledge, skills, abilities, social experience and moral standards in the younger generation.

As the President of the Republic of Uzbekistan Sh.M.Mirziyoev noted in his book “Together we will build a free and prosperous, democratic state of Uzbekistan”, “Our children must be stronger, more educated, wiser and, of course, happier than us!” that is vital to encourage all of us, parents and occupies a firm place in the minds and hearts of the public at large. To this end, the Government, relevant ministries and agencies as well as the entire education system, a respected teacher and teachers is the most important task of the young generation, teaching them physically and spiritually mature individuals consists of raising our thoughts”, it is seen that the

education of their youth spiritual and moral upbringing, education and the present is one of the most urgent tasks. [1]

Of course, one of the urgent tasks in educating and upbringing the younger generation is, first of all, national upbringing, self-awareness, increasing the sense of love for the Motherland, assimilation on the basis of national traditions and values. On this basis, in the organization of the educational process, along with preparing our youth for family life, respect for adults in the family, respect for children, kindness, care, patience, tolerance, flexibility, patriotism, courage, intelligence, courage, teaching boys and girls a culture of communication. covers into.

The Encyclopedia of Education, intended for use by parents and educators, provides the following ideas for the term "education." Education is used in a broad and narrow sense. In a broad sense, it means a set of all institutions, activities, actions, aspirations aimed at shaping the human personality, its socialization and active participation in social, political, cultural, enlightenment life. [2]

From the above, it is clear that education should be carried out not only in the family, but also in educational institutions, neighborhoods, organizations working with young people. Including:

- cinema;
- radio
- television;
- theater;
- media and others.

In the narrow sense, upbringing is a special activity aimed at developing a person's physical development, worldview, spiritual and moral image, aesthetic taste. In this case, education is provided by family and educational institutions, as well as public organizations. [2]

- Today, the educational process is one of the most sensitive issues. Issues of education in the works of our great ancestors and thinkers:
  - upbringing a perfect person
  - raising children in the family
  - factors influencing the formation of the child's personality
  - moral qualities of the child
  - legal duties
  - sense of responsibility
  - pride
  - reflected in their works valuable thoughts and ideas for parents and teachers on issues of honor.

When we say a perfect person, we mean, first of all, a person with a high culture, spiritual and moral, mental and physical development, respect for national values and traditions, an example to all by his upbringing, the ability to think independently and logically.

In the section “Features of upbringing in modern Uzbek families” of the manual “Family pedagogy” by A.K. Munavvarov, one of the founders of family pedagogy, the complexity of family upbringing, the fact that each child is a unique world, a unique community of society, that is why it is inconvenient and difficult to generalize the forms and methods of family upbringing and give them any recommendations. In particular, the more spiritually rich, faithful, and highly educated parents are, the more they raise their children in an improved way. It is said that they not only give advice, approval, reward, punishment, conversation and storytelling, exchange of ideas, but also nurture their personal examples by working with their children, involving them in labor activities. [3]

The high culture, morals, and respect for the elders of our youth, respect for the little ones, national values and traditions, respect and love for the Motherland are realized through the upbringing of the parents in the family. But today it is a pity that there are some problems in the upbringing of our youth. Unfortunately, today some young people have disrespect for their parents in the family, lack of culture of treatment, and disrespect for traditions. The main reason for this is the wrong upbringing of the child in the family, among some of our young people brought up in the wrong homes, as well as in the "Homes of Mercy".

Another reason for the above is that various media shows, low-quality movies and songs, various Internet sites, virtual games, virtual friends, the way young people in Western countries dress and imitate various slang words have a negative impact on the upbringing of children.

In fact, in the process of raising a child in the family, the parent must work on himself with a clear goal, that is, be able to choose the right methods and techniques of parenting and have pedagogical skills.

In the process of upbringing, it is expedient to provide the child with such economic, religious, mental, legal, labor, spiritual, moral, aesthetic, civic, physical, ecological upbringing, depending on the characteristics of his age. This is because the child is able to set goals for the future, to feel a sense of responsibility, to show kindness to parents, brothers, sisters, children and other close relatives in the family, to maintain the independence of the family. must be a comprehensive mature specialist.

*In addition, the responsibility of parents in raising children in the family is very important. They are:*

- follow a healthy lifestyle for every child;
- sports and training;
- compliance with hygienic requirements and rules;
- imparting religious and secular knowledge;
- Proper organization of the child's free time;
- Ensuring participation in various clubs;
- teaching a culture of communication and communication;
- aesthetic education;
- adherence to the rules of etiquette;

- formation of patriotic feelings;
- age-appropriate interviews;
- providing economic and legal knowledge;
- teaching to read books;
- set a clear goal;
- overcoming life's difficulties;
- prevention of family conflicts and others.

Parental responsibility is a very complex process. Every child has their own world, habits, character traits, interests. In the minds of parents, a child may not be the perfect person they want to be. But it is an important task for parents to further develop their worldview, to pay attention to their shortcomings, feelings, the uniqueness of each child, their innate abilities and talents.

In conclusion, it should be noted that today for the children of all families in our country should be responsible not only professionals working in the field of education, but also the entire population of Uzbekistan. It is not for nothing that our people say, "Seven neighboring parents for one child." The upbringing of a father in the family is especially important in the upbringing of boys to be courageous, hardworking, family-oriented, and to grow up to be loyal, courageous sons for the Motherland and their families. In the upbringing of girls, the role of the mother is invaluable in shaping the skills of housekeeping, culture of hospitality, diligence, the ability to find the right solution to various conflicts in the family. For the girls a big step into a new life qayniona, qayniota, his wife, his wife's close relatives and neighbors respect to the treatment of the brides, women, mothers carry out the responsibilities of the mother for the child's upbringing, life lessons, life experiences takes place.

## REFERENCES

1. Together we will build a free and prosperous, democratic state of Uzbekistan. Speech at the joint session of the chambers of the Oliy Majlis dedicated to the inauguration of the President of the Republic of Uzbekistan. T.: - "Uzbekistan" - 2016 14 b.
2. Aminov M.N., "Educational encyclopedia", "National encyclopedia of Uzbekistan" State scientific publishing house T.: .2010 y. 3 pages.
3. Handbook of A.K. Munavvarov "Family pedagogy". Tashkent. "Teacher" 1994 53 b.



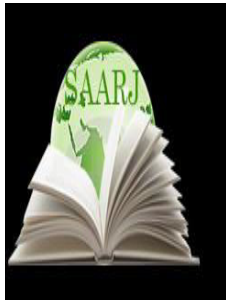

**ACADEMICIA**  
**An International**  
**Multidisciplinary**  
**Research Journal**  
 (Double Blind Refereed & Peer Reviewed Journal)

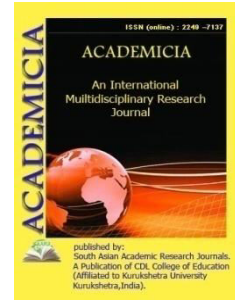

**DOI: 10.5958/2249-7137.2021.01879.6**

### CHOOSING THE BEST OPTION

**Saipnazarov Shaylovbek Aktamovich\*; Khodjabaeva Dilbar\*\***

\*Associate Professor,  
 Candidate of Pedagogical Sciences, Tashkent University of Economics,  
 UZBEKISTAN

Email id: shaylovbek.s.a@gmail.com

\*\*Senior Lecturer,  
 Tashkent University of Economics,  
 UZBEKISTAN

Email id: dxodjabaeva@gmail.com

#### ABSTRACT

*In this article, we analyzed several simple educational examples with small number of variables, in which you can get solutions using mathematics known to students in grades 7-10, proportions, properties of a linear function of no larger variable, a small enumeration of options. Methods for solving integer programming problems are also considered.*

**KEYWORDS:** *Optimal, Best Option, Largest, Smallest, Integer Variable, Simplex Method, Basic Variable, Non-Basic Variable.*

#### INTRODUCTION

The problems of drawing up equations have, firstly to deal the translation of a condition from an ordinary language into a mathematical one, and secondly, to solve the resulting equations and inequalities. It is important to be able to solve such problems, sine in industrial and economic practice it is often necessary to summarize, recalculate and summarize various indicators, analyze the work of enterprises, etc. The result of this activity is an understanding of the current situation. After that, is it natural to take the next step-to draw up a plan-a program of further actions. Here, of course, many options formulation and solution of such problems are the subject of mathematical programming. In the process of solving problems with production content, we mean, first of all, instilling the ability to identify cause-and-effect relationships between economic factors and their mathematic interpretations. Was the soviet mathematician, academician L.V Kantorovich (1912-1986). In 1939 his book “Mathematical Methods of Organization and Planning of Production “was, published. In the introduction to this book, he

efficiency of a shop, an enterprise and an entire industry. One way is various improvements in technology, that is, new devices in a separate machine, changing the technological process, so far less used, is through improvements in production organization and planning. This includes, for example, such issues as the distribution of work between individual machine tools of an enterprise or mechanisms, the correct distribution of various types of raw materials, fuel, etc.

Many years have passed since then, and mathematical programming has become a goal of science, based on economics, mathematical methods and widely using computers. In real planning and control problems, one has to deal simultaneously with a very large number of variables. We will walk through a few simple examples with a small number of variables.

**Example-1.** Three alloys were brought to the laboratory. The first contains 40 percent copper and 60 percent nickel, the second 60 percent copper and 40 percent cobalt, the third 60 percent nickel. For the experiment, 1kg of a new alloy was needed, which would contain 40 percent cobalt and as little copper as possible (see table). How to make it?

**Solution.** Let's make a mathematical model of the problem. Take  $x$  kg

	+Cu	Ni	Co
1	40%	60%	-
2	60%	-	40%
3	-	40%	60%

of the first alloy,  $y$  kg of the second and  $z$  kg of the third.

By hypothesis  $x + y + z = 1$ .

Cobalt in the new alloy will be  $0,4y + 0,6z$ . Again, by condition  $0,4y + 0,6z = 0,4$

Copper in the new alloy will be  $0,4x + 0,6z$ . So, the model is built: it is required to find non-negative numbers  $x, y, z$  that satisfy the system of equations

$$x + y + z = 1$$

$$0,4y + 0,6z = 0,4.$$

and for which the value of  $f(x, y) = 0,4x + 0,6y$  takes the smallest value.

Using the system of equations, we express  $x$  and  $z$  in terms of  $y$  and substitute their values into the smallest value of the resulting function of  $y$  (taking into account, of course, that all variables  $x, y$  and  $z$  must be non-negative).

From the second equation

$$z = \frac{2}{3} - \frac{2}{3}y.$$

Substitute this  $z$ -value into the first equation:

$$x = \frac{1}{3} - \frac{1}{3}y.$$

That's why

$$f(x, y) = \frac{2}{15} + \frac{7}{15}y.$$

Note that here we came across a linear function

$$f(x, y) = \frac{2}{15} + \frac{7}{15}y,$$

Which takes the smallest value at the smallest value  $y = 0$ . If we expressed  $f(x, y)$  not in terms of  $y$ , but in terms of  $x$  or  $z$ , it would be more difficult to find out in which interval we should search for its smallest value. How best to choose which variable to reduce a function to is also an important task.

**Example-2.** It was decided to buy Christmas tree decorations for \$100. Christmas decorations are sold in sets. A set of 20 toys costs \$4, a set of 35 toys cost \$6, and a set of 50 toys costs \$9. How many and which nobles do you need to buy in order to buy the largest number of toys?

**Solution.** One toy in the first set costs  $\frac{1}{5}$ , in the second set  $\frac{6}{35}$ , in the third set  $\frac{9}{50}$ . Let's order these numbers:  $\frac{6}{35} < \frac{9}{50} < \frac{1}{5}$ .

So, the cheapest toys are in the second set, and the most expensive ones are in the first.

1	2	3
20	35	50
4\$	5\$	9\$

1	2	3
1pc	1pc	1pc
$\frac{1}{5}$ \$	$\frac{6}{35}$ \$	$\frac{9}{50}$ \$

To buy as many toys as possible for \$100, of course, you need to buy more cheap toys. At most, we can buy 16 sets at \$6-and spend \$96 on it. There remains \$4, for which you can only buy the first set. In total, we will buy  $16 \cdot 35 + 20 = 580$  toys in this way

This is most likely the best option. So, you need to buy 16 sets for \$6 and 1 for \$4. At the same time, 580 toys will be purchased.

We arrive at this answer with the help of such a natural reason: you can buy the more toys, the cheaper they are. Our reasoning is plausible, but, generally speaking, we have not looked through all the possible options. Therefore, we present a more rigorous solution.

Let  $x$  be the number of sets of type 1,  $y$  – 2 types,  $z$  – 3 types. It is necessary to find such non-negative numbers  $x, y, z$ , so that conditions  $4x + 6y + 9z \leq 100$  are fulfilled and the value  $S = 20x + 35y + 50z$  is the largest.

Since

$$4x + 6y + 9z = \frac{6}{35}S + \frac{4}{7}x + \frac{3}{7}z \geq \frac{6}{35}S,$$

It turns out that  $\frac{6}{35}S \leq 100$ , whence  $S \leq 583\frac{1}{3}$ . by 5, we have  $S \leq 580$ . For  $x = 1, y = 16$ , all conditions are satisfied and  $S = 580$

This task belongs to integer programming, which is one of the most difficult areas of mathematical programming. A number of methods are used to solve linear integer programming problems. The simplest of these is the conventional linear programming method. If the

components of the optimal solution turn out to be non-integer, they will be rounded to the nearest whole numbers. This method is used when a single unit of the population makes up a small part of the entire population. Otherwise, rounding can lead to a far from optimal target solution, therefore, specially developed methods are used.

Integer optimization methods can be divided into three main groups: 1) cut-off methods; 2) combinatorial methods; 3) approximate methods. Let's dwell on the clipping methods. The essence of pruning methods is that at first the problem is solved without the integer condition.

If the resulting plan is integer, the problem is solved. Otherwise, a new constraint is added to the constraints of the problem with the following properties:

- 1) it must be linear,
- 2) It must cut off the optimal non-integer plan found;
- 3) Must not cut off any integer plan.

Further, the problem is solved taking into account the new constraint. After that, if necessary, one more restriction is added, etc.

The linear integer programming problem is formulated as follows: find a solution  $X = (x_1, x_2, \dots, x_n)$ , such that the linear function

$$Z = \sum_{j=1}^n c_j x_j \tag{1}$$

takes the maximum or minimum value under the constraints

$$\sum_{i=1}^n a_{ij} x_j = b_i, i = 1, 2, \dots, m \tag{2}$$

$$x_j \geq 0, j = 1, 2, \dots, n \tag{3}$$

$$x_j - integers \tag{4}$$

Let the linear programming problem (1)-(4) have a finite optimum and at the last step its solution by the simplex method the following equations are obtained expressing the main variables  $x_1, x_2, \dots, x_i, \dots, x_m$  in terms of the minor variables  $x_{m+1}, x_{m+2}, \dots, x_n$  of the optimal solution

$$\begin{cases} x_1 = \beta_1 - \alpha_{1m+1}x_{m+1} - \dots - \alpha_{1n}x_n, \\ \dots\dots\dots \\ x_i = \beta_i - \alpha_{im+1}x_{m+1} - \dots - \alpha_{in}x_n, \\ \dots\dots\dots \\ x_m = \beta_m - \alpha_{mm+1}x_{m+1} - \dots - \alpha_{mn}x_n \end{cases} \tag{5}$$

The optimal solution to problem (1)- (3) is

$$X^* = (\beta_1, \beta_2, \dots, \beta_i, \dots, \beta_m, 0, 0, \dots, 0)$$

in which, for example,  $\beta_i$  is a noninteger component. In this case, one can prove that the in equality

$$\{\beta_i\} - \{\alpha_{im+1}\}x_{m+1} - \dots - \{\alpha_m\}x_n \leq 0 \quad (6)$$

formulated according to the 1-st equation of system (5), has all the properties of correct cutting. Inequality (6) contains the symbol  $\{ \}$ , meaning the fractional part of the number.

To solve the integer linear programming problem (1)-(4) by the cut- of methods, the following algorithm is used:

1. Solve problem (1)-(3) using the simplex method without taking into account the integer condition. If all components of the optimal plan are integer, then it is also optimal for integer programming problems (1)-(4). If the first problem (1)-(3) is unsolvable, then the second problem (1)-(4) is also unsolvable.
2. If there are non-integral components among then components of the optimal solution, then select the component with the largest integral part and form the correct cutoff (6) using the corresponding equation of system(5).
3. Inequality (6) by introducing an additional nonnegative integer variable transform into an equivalent equation

$$\{\beta_i\} - \{\alpha_{im+1}\}x_{m+1} - \dots - \{\alpha_{in}\}x_n + x_{n+1} \leq 0 \quad (7)$$

4. Solve the resulting extended problem using the simplex method. If the found optimal plan is integer, then the integer programming problem (1)-(4) is solved. Otherwise, go back to algorithm 2.

**Example-3.** For the purchase of equipment for sorting grain, the farmer allocates 34 monetary units. The equipment must be located on an area not exceeding 60sq.m. the farmer can order two types of equipment: less powerful type *A* machines costing 3 monetary units, which requires a production area of 3 square meters (including aisles) and providing a productivity per shift of 2 tons of grain, and more powerful type *B* machines costing 4 monetary units, occupying an area of 5 square 4 meters and providing a productivity per shift of 3tons of high-quality grain.

An optimal equipment procurement plan is required ensure maximum overall productivity, provided the farmer can purchase no more than 8 type *B* machines.

**Solution.** Let us denote by  $x_1, x_2$  the number of machines of type *A* and *B*, respectively, by *Z*-the total productivity. Then the mathematical model of the problem will take the form:

$$Z = 2x_1 + 3x_2 \rightarrow \max \quad (1')$$

We the constraints:

$$\begin{cases} 3x_1 + 5x_2 \leq 60 & (1) \\ 3x_1 + 4x_2 \leq 34 & (2) \end{cases} \quad (2')$$

$$\begin{cases} x_2 \leq 8 & (3) \end{cases} \quad (3')$$

$$x_1 \geq 0, x_2 \geq 0, x_1, x_2 - \text{whole numbers} \quad (4')$$

Let us reduce the problem to the canonical form by introducing additional nonnegative variables  $x_3, x_4, x_5$ . We get a system of restrictions:

$$\begin{cases} 3x_1 + 5x_2 + x_3 & = 60 \\ 3x_1 + 4x_2 & + x_4 = 34 \\ x_2 & + x_5 = 8 \end{cases} \quad (5')$$

$$x_j \geq 0, j = 1, 2, \dots, 5$$

Solving the problem using the using the simplex method

**Step 1.** Major variables  $x_3, x_4, x_5$ , minor variables  $x_1, x_2$ .

$$\begin{cases} x_3 = 60 - 3x_1 - 5x_2 \\ x_4 = 34 - 3x_1 - 4x_2 \\ x_5 = 8 - x_2 \end{cases}$$

$$Z = 2x_1 + 3x_2$$

First basic solution  $X_1 = (0; 0; 60; 34; 8)$ - admissible. The corresponding value of the linear function  $Z_1 = 0$ . We translate into the main variable  $x_2$ , which allows us to accept the system of restrictions, from the condition of the minimum of the corresponding relations

$$x_2 = \min\left(\frac{60}{5}; \frac{34}{4}; \frac{8}{1}\right) = 8,$$

for  $x_2 = 8$  in this equation  $x_5 = 0$ , and the variable  $x_5$  goes to non-basic ones.

**Step 2.** Major variables  $x_2, x_3, x_4$ ; minor variables  $x_1, x_5$ .

$$\begin{cases} x_2 = 8 - x_5 \\ x_3 = 20 - 3x_1 + 5x_2 \\ x_4 = 34 - 3x_1 + 4x_2 \end{cases}$$

$$Z = 24 + 2x_1 - 3x_5$$

$$X_2 = (0; 8; 20; 2; 0); Z_2 = 24.$$

We translate into the main variable  $x_1$ ,

$$x_1 = \min\left(\infty; \frac{20}{3}; \frac{2}{3}\right) = \frac{2}{3},$$

and the non-main variable  $x_4$ .

**Step 3.** Major variables  $x_1, x_2, x_3$ ; minor variables  $x_4, x_5$ .

After the transformations, we get

$$\begin{cases} x_1 = \frac{2}{3} - \frac{1}{3}x_4 + \frac{4}{3}x_5 \\ x_2 = 8 - x_5 \\ x_3 = 18 + x_4 + x_5 \end{cases}$$

$$Z = 25\frac{1}{3} - \frac{2}{3}x_4 - \frac{1}{3}x_5$$

The basic solution  $x_3$  is optimal for problem (1') – (3'), since there are no non-basic variables with positive coefficients in the expression of the linear function. However, solution  $x_3$  does not



satisfy the integer condition (4'). According to the first equation with variable  $x_1$ , which received a non-integer value in the optimal solution  $\frac{2}{3}$ , we compose an additional constraint (6):

$$\left\{\frac{2}{3}\right\} - \left\{\frac{1}{3}\right\}x_4 - \left\{\frac{4}{3}\right\}x_5 \leq 0$$

Since the fractional parts are

$$\left\{\frac{2}{3}\right\} = \left\{0 + \frac{2}{3}\right\} = \left\{\frac{2}{3}\right\},$$

$$\left\{\frac{1}{3}\right\} = \left\{0 + \frac{1}{3}\right\} = \left\{\frac{1}{3}\right\},$$

$$\left\{-\frac{4}{3}\right\} = \left\{-2 + \frac{2}{3}\right\} = \left\{\frac{2}{3}\right\},$$

we can write the last inequality in the form

$$\frac{2}{3} - \frac{1}{3}x_4 - \frac{2}{3}x_5 \leq 0 \quad (6')$$

Introducing an additional integer variable  $x_6 \geq 0$ , we obtain the equation equivalent to inequality (6')

$$\frac{2}{3} - \frac{1}{3}x_4 - \frac{2}{3}x_5 + x_6 = 0 \quad (7')$$

**Step 4.** Basic variables  $x_1, x_2, x_3, x_5$ ; non-basic variables  $x_4, x_6$

We get after the transformations:

$$\begin{cases} x_1 = 2 - x_4 + 2x_6 \\ x_2 = 7 + \frac{1}{2}x_4 - \frac{3}{2}x_6 \\ x_3 = 19 + \frac{1}{2}x_4 + \frac{3}{2}x_6 \\ x_5 = 1 - \frac{1}{2}x_4 + \frac{3}{2}x_6 \end{cases}$$

$$Z = 25 - \frac{1}{2}x_4 - \frac{1}{2}x_6$$

$$x_5 = (2; 7; 19; 0; 1; 0)$$

$$Z_5 = 25$$

So,  $Z_{max} = 25$  for the optimal integer solution  $X^* = x_5 = (2; 7; 19; 0; 1; 0)$ , i.e. the maximum productivity of 25 tons of high-quality grain per shift can be obtained by purchasing 2 machines of type A and 7 machines of type B, while the unoccupied area of the premises will be 19sq.m, cash balances from the allocated funds are equal to 0, in the reserve for purchase-1 car of type B.

## **CONCLUSIONS**

In our opinion, it is useful for students of all faculties of an economic university to get acquainted with the methods of mathematical programming, the creation of which is associated with the urgent needs of planning and organizing production.

Deepening of economic ties between different branches of the National economy, an increase in the scale of production not allow you to do without quantitative methods of economic calculations and usage of modern computers.

Methods of mathematical programming make it possible to allocate limited resources in the most rational way: whether it is the problem of the best use of limited production resources for the release of a certain set of products, the so-called production planning problem of the most efficient use of vehicles for the transportation of a given volume of products, a transport problem. At the same time, linear programming allows you to obtain such a distribution accurately, and not by eye.

## **LITERATURE**

1. Voronin S.M., Kulagin A.G. About the problem of the Pythagorean// kvant. -1987-№1 – page 11-13.
2. Kushnir I.A, Geometric solutions of non-geometric problems// kvant. -1989 - №11 p. 61-63
3. Boltyansky V.G. Coordinate direct as a means of clarity// Math at school. -1978. -№1-p. 13-18.
4. Н.Ш.Кремер и другие“Исследование операций в экономике» М.:1997,-407с.
5. L.D.Hoffmann, G.L.Bradley “Finite mathematics with calculus” New York, 1995,-1018.
6. Saipnazarov Sh.A., Gulamov A.// Analytic and graphical methods for the analysis of equations and their analysis. Physics, Mathematics and Informatics. -2016. -№ 3 –p/ 56-60.
7. Saipnazarov Sh.A., Yakubova.U., Dilbar Khodjabaeva// Improvement of economic knowledge of students when training mathematics. ACADEMICIA: An International Multidisciplinary Research Journal. 9, Sept 2020 316-323
8. Saipnazarov Sh.A., Dilbar Khodjabaeva// Various ways to solve problems at the extreme. INNOVATION IN SCIENCE, EDUCATION AND TECHNOLOGY LONDON 2020
9. Saipnazarov Sh.A., Dilbar Khodjabaeva// APPLYING INEQUALITIES TO CALCULATING. ACADEMICIA: an international multidisciplinary Research Journal [https:// saarj.com](https://saarj.com)

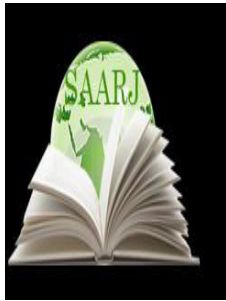

**ACADEMICIA**  
**An International**  
**Multidisciplinary**  
**Research Journal**  
 (Double Blind Refereed & Peer Reviewed Journal)

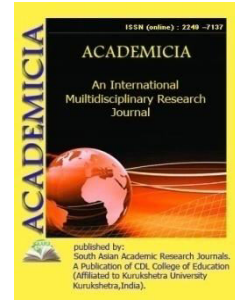

**DOI: 10.5958/2249-7137.2021.01880.2**

## PSYCHOLOGICAL AND PEDAGOGICAL PROBLEMS OF AN INCOMPLETE FAMILY

**Shaumarova Zilola Abdushukurovna\***

\*Lecturer of the Department of Military-Patriotic,  
 Doctor of Philosophy in Pedagogical Sciences, (PhD),  
 Spiritual-Enlightenment Education and Social Work with Youth,  
 University of Public Security of the Republic of UZBEKISTAN

### ABSTRACT

*The article presents an analysis of recent studies on the problems of incomplete families. Most researchers classify an incomplete family in the category of dysfunctional families. In an incomplete family, there is a violation in the very structure of the family. The absence of one of the parents affects the formation of the child's personality and creates problems in his socialization. One of the most difficult defects in socialization are defects in family socialization, which leads to a number of deviations, including violations of legal behavior. Therefore, the problem of an incomplete family is an interdisciplinary problem. The results of the analysis of sociological, pedagogical, psychological and legal research carried out by domestic scientists led to a conclusion about the relevance of this problem. A dysfunctional family is seen as a factor in the deformation of a child's behavior. In this regard, the socio-pedagogical characteristics of the incomplete family are presented, as well as the psychological and legal problems of incomplete families are described.*

**KEYWORDS:** *Family, Single-Parent Family, Child, Psychological Support, Culture, Socialization of Children, Defects Of Socialization*

### INTRODUCTION

The family has always been an important social institution, the purpose of which is to form such qualities and personality traits that will help to adequately overcome difficulties and obstacles encountered on the path of life. She is obliged to form a physically and mentally healthy, intellectually developed, highly moral personality, ready for the upcoming work, social and family life. The first life experience of a child is his adaptation to the system of family and kinship relations, this is not always easy and can affect the relationship with society. Children

acquire the skills and abilities of socio-pedagogical adaptation to the character and temperament of other people, in this case, family members, and if there are any negative moments in the family, they may well affect the child's outlook and well-being. The influence of family upbringing can be seen on the example of upbringing in complete and incomplete families. A complete family is a social unit consisting of a parent and a child or several children. Incomplete family - a family consisting of: a woman who gave birth to children out of wedlock and is not married; widows and widowers who have not entered into a new marriage. It is also a family consisting of a father and mother, who live separately due to divorce; single people who have adopted children. Unfortunately, today the tendency of family disintegration is increasing, which is an acute social problem and is the subject of study by a large number of researchers.

Analysis of scientific research in recent years has shown that the problem of incomplete families in the country is quite acute. The modern family is in a state of crisis, which is expressed in the form of such processes as a decline in living standards and health, a sharp increase in the number of divorces of spouses, domestic crime and an increase in family conflicts, a decrease in the pedagogical potential of the family and the possibility of developing a harmonious full-fledged personality of a future member of society.

Unfortunately, psychological and pedagogical theory and practice lag behind the requirements of the times. Currently, they are faced with the goal of forming the means and ways of including a child from an incomplete family in the system of full-fledged child-adult relations, neutralizing the child's negative experiences and actions, and helping the family overcome difficulties. In scientific terms, this problem acts as an interdisciplinary one, which is explained by the interconnection of psychological, pedagogical, sociological, criminological, medical and other aspects. Therefore, the synthesis of such approaches and ideas can make it possible to find a reasonable solution to the practical and theoretical problems of educating schoolchildren and adolescents from single-parent families. Each of these sciences considers various aspects of the process of life and development of the family. The plurality of approaches to the study of the family brings a different interpretation of this concept, which distinguishes different family characteristics as system-forming relationships.

Problems of incomplete families Problems of incomplete families, taking into account regional characteristics, were studied by V. Karimova, Z. Shoumarova, and others aimed at considering the problem of institutionalization of an incomplete family consisting of children and one of the parents (most often the mother) in a transforming society.

A deep theoretical analysis of domestic and foreign philosophical, sociological, pedagogical, socio-psychological and legal literature makes it possible to develop a coherent program for a comprehensive study of the problems of incomplete families. An analysis of the characteristics of an incomplete family was presented by L.K. Rashitov. Of interest is the identified and described by L.K. Rashit's specificity of problems, where new sources of formation of incomplete families are presented (adoption, the use of methods of artificial insemination).

A comparative analysis of the works of domestic and foreign authors in the field of sociology, pedagogy, psychology, jurisprudence showed that it is necessary to focus on taking into account the specifics of the conditions of a particular region. Most studies of the problems of incomplete families from the standpoint of psychological and pedagogical science are directed to the conditions for the development of the child's personality [Ivanchenko, 2010; Myagkova, 2010;

Nafikova, 2009; Rashitova, 2009; Chertkoeva, Khadikova, 2016; Yakushenko, 2007]. V.A. Ivanchenko [Ivanchenko, 2010]. V.A. Ivanchenko proposed a refined model of the life cycle of an incomplete family, which includes the following stages: marriage, the birth of children, family breakdown, adaptation to a breakup situation, acceptance of monoparenthood, growing up of children, psychological and legal problems of children, creation of a new family.

The existence of an incomplete family in the present is mainly due to the following signs: the death of one of the spouses, the relatively widespread illegitimate birth, the breakdown of marriages. As for the first reason, at present its share among other reasons is not so high. Illegal fertility takes a more significant place in the formation of an incomplete family; it is supported by the growth of extramarital affairs among young people, which is facilitated by the weakening of control on the part of the family and the state, as well as the lack of family and sex education.

Thus, out of 17 million families, about 6 million are incomplete. Moreover, 5 million are single mothers. That is, almost a third. Can we talk about a trend? In order to answer the question about the trend, it is necessary to clarify who is a single mother for social protection services. And these are single mothers who were not married at the time of the birth of the child, as well as who received status as a result of divorce or the death of their spouse. Also, the status of a certain number of single mothers is fictitious. Women protect him to preserve social benefits, which can be a serious help in family life. I would not like to talk about the crisis of the traditional complete family.

It is necessary to talk about several factors at once, under the influence of which this trend has developed. Standards of a decent standard of living are changing, parenting is perceived hyperresponsibly, the ideas of "conscious" parenting are in the air. Not all men are ready to shoulder the burden of raising children on these terms. We can talk about the tendency to infantilize the generation of the "zero" and "tenth" years. It is now almost impossible to establish the period of maturity. Previously, such a moment was the completion of a higher educational institution, the acquisition of a profession. Now the concept of a profession is becoming increasingly blurred, the ideas of lifelong education are being promoted; in these conditions, fatherhood may seem like a too hasty step. Young women also experience this pressure, but many understand that the reproductive functions and health of the female body are much more reflected in the health of the child, and they do not improve with age.

But the main thing, it seems to me, is a general significant increase in the age of women who decide to have their first child, as well as an increase in the age at which they get married. So, the age of primiparous mothers today has exceeded 25 years. As a rule, women at this age are already quite independent economically

Raising children in an incomplete family that has survived a divorce, death or departure of one of the parents becomes a serious challenge, taking on increased responsibility, adapting to changes in their role and financial situation, guardian parents often fail in attempts to adapt to changed living conditions in addition to them it is necessary to overcome the established social prejudice that an incomplete family is flawed, since caring for children is beyond the power of one, which means that in such a family the potential for raising children with partial ideas about the family, "problem children" increases. This public stigma is both just and unjust at the same time. The more a single parent depends on such a stereotype, the less confident he is in himself and his abilities as a teacher, the more children suffer from his feelings of inferiority. While two parents

who share childcare within the same home can split the work and provide mutual support, single parents, mums or dads, often become great parents after passing the test of the enormous responsibility placed on one shoulders. They can develop remarkable abilities.

First, parents who have children in their care tend to speak frankly with them and establish strict rules. They know that confidential communication, firmness in setting boundaries and the requirement to respect them hold the family together.

Second, these parents learn to cope with different responsibilities at the same time and to act effectively. After all, now the functions they perform are much more diverse, and there is less time for everything than before.

Third, single parents are more responsible: they understand that almost all the daily responsibilities of caring for a child fall on their shoulders.

Fourthly, they gradually realize that they cannot achieve anything on their own, and they get out of the shell of loneliness, communicating with other people, finding support and support in them. In the best case, when there is an appeal to specialists who are ready to provide professional psychological and pedagogical support. Such support is absolutely necessary for them, because single parents are a part of society, which, despite its size and a huge number of problems, is very lacking in attention and care. The social, emotional and economic pressures on such families are enormous.

## CONCLUSION

Thus, the analysis of sociological, pedagogical, psychological, legal research in recent years has shown that the problems of incomplete families are mostly reflected in sociological and pedagogical works. We have to state an acute shortage of psychological and legal research on the phenomenon of incomplete families. Most researchers attribute an incomplete family to problem families, since children raised in single-parent families not only develop psychological and personal problems, but most often they have defects in the formation of legal consciousness, which leads to deviant or criminal behavior.

Despite this, the problem of incomplete families has not been sufficiently studied in legal psychology. In the future, psychological research can be addressed to various levels of solving the problems of an incomplete family: general scientific (selection of psychological tools for studying the indicated problem), theoretical (interpretation of socio-psychological trends) and technological (development of programs for psychological support of an incomplete family). This will expand the understanding of the specifics of the functioning of an incomplete family, the possibilities of social, psychological, pedagogical and legal assistance to the family and the features of psychological support for the development of a child's personality in an incomplete family, harmonization of interpersonal relations in the family, measures to prevent defects in illegal behavior.

## LITERATURE

1. Decree of the President of the Republic of Uzbekistan dated February 7, 2017 No PF-4947 "On the Action Strategy for further development of the Republic of Uzbekistan".
2. Kameneva T.N. Motherhood in an incomplete family: personal and social problems. / Dissertation and abstract for the degree of candidate of sociological sciences. - Kursk, 2003.



3. Kirikova M.I. Increasing the educational potential of an incomplete family in a center for social assistance to families and children. / Dissertation and abstract for the degree of candidate of pedagogical sciences. - Moscow, 2009.
4. Korenkova T.V. Formation of a parent's pedagogical culture in an incomplete family in the context of the activities of social institutions. / Dissertation and abstract for the degree of candidate of pedagogical sciences. - Stavropol, 2004.
5. Nikolaeva Ya.G. Pedagogical conditions for improving the process of raising children in an incomplete family: on the material of the Chuvash Republic. / Dissertation and abstract for the degree of candidate of pedagogical sciences. - Cheboksary, 2003.
6. Noskova M.V. Socio-psychological characteristics of parent-child relationships in incomplete paternal families. Dissertation and abstract for the degree of candidate of psychological sciences. - Moscow, 2010.
7. Kameneva T.N. Motherhood in an incomplete family: personal and social problems. / Abstract for the degree of candidate of sociological sciences. - Kursk, 2003.
8. Nikolaeva Ya.G. Pedagogical conditions for improving the process of raising children in an incomplete family: on the material of the Chuvash Republic. / Abstract for the degree of candidate of pedagogical sciences. -Cheboksary, 2003.
9. M.N.Ismoilov. Bolalarvao'smirlargigiyenasi. Darslik. Toshkent 1994.  
<https://estalsad2.edumsko.ru/activity/soveti/post/160664>
10. Shaumarova Z.A. Factors influencing the socialization of the child's personality in an incomplete family // European Journal of Research and Reflection in Educational Sciences, Great Britain, Progressive Academic Publishing, 2019. P.48-52. (13.00.00 №3)
11. Шаймарова З.А. Classification of single-parent families and their social-psychological-pedagogical // ACADEMICIA: An International Multidisciplinary Research Journal ISSN: 2249-7137 Vol. 10 Issue 5, May 2020 Impact Factor: SJIF 2020 = 7.13. P. 1233-1237. (10.5958/2249-7137.2020.00332.8)
12. Shaumarova ZA Socio-pedagogical problems of inadequacy // Modern education. - Tashkent vil., 2017. –№ 6. –53-58 p. (13.00.00 №10)
13. Shaumarova ZA The case of non-family members studied by foreign scholars // Modern education. - Tashkent vil., 2018. –№ 10.–3-8 p. (13.00.00 №10)
14. Shaumarova ZA Psychological and pedagogical problems of child personal development in a non-family // School life. - Tashkent, 2018. –№ 8. –20-22 p. (13.00.00 №4)
15. Shaumarova ZA Effective ways of child personal development in a non-family // School life. - Tashkent, 2019. –№ 6. –13-15 p. (13.00.00 №4)
16. Shaumarova ZA Notarized family-pedagogical system of personal education in the family // Zamonavitaylim. – Tashkent v., 2020. –No. 11. –14-21 p. (13.00.00 No10)
17. Shaumarova ZA Problems of personal development of a child in a non-family // Material and procedural issues of legal protection of minors. Republican scientific-practical materials.– Tashkent, 2018. –p.44-46.

18. Shaumarova ZA Pedagogical problems in the formation of the child's personality in a non-family // Prospects of pedagogical science in Uzbekistan. Collection of Republican scientific-practical articles. - Tashkent, 2019. - pp. 297-298.
19. Shaumarova Z.A. Social experience of Uzbekistan in solving the problems of an incomplete family // XLVI International correspondence scientific and practical conference European research: innovation in science, education and technology. - London, United Kingdom. 2018. -42-44 p.
20. Шаумарова З.А. The role of the father in the education of a child in an incomplete family // LI International correspondence scientific and practical conference European research: innovation in science, education and technology.– London, United Kingdom. 2019. –31-33 p.

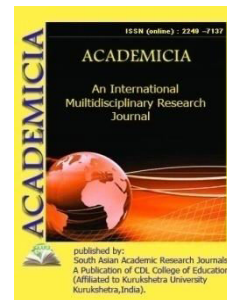

DOI: **10.5958/2249-7137.2021.01881.4**

## PROBLEMS OF LEXICOGRAPHIC INTERPRETATION OF PHRASEOLOGICAL POLYSEMIS OF UZBEK LANGUAGE

**Rakhimova S.J\***

\*Teacher,

Native language and literature of academic lyceum,  
Urgench branch of Tashkent University of Information Technologies,  
Named after Muhammad al-Khwarizmi,  
UZBEKISTAN

### ABSTRACT

*The following article deals with certain conclusions based on a lexicographic analysis of phraseological polysemy. The study of the topic is classified and treated to a certain extent. Some suggestions are made on the basis of examples of the meanings of phraseological units expressed in the context, the differentiation of ambiguity and semantics of phrases, the interpretation of their presentation in dictionaries.*

**KEYWORDS:** *Lexicography Polysemy, Phrasing, Ambiguity In Expressions, Semantics, Semantics, Stylistics, Linguistic Possibility.*

### INTRODUCTION

The phrase eliminates the ambiguity in speech, both in context and in the context of speech. If the exponent changes without affecting the core semantics, the context will be variable. The phrase is free and subject only to the general laws of word compatibility in the language. Sometimes the basic and grammatical means interact with each other's semantics to form an inseparable semantic connection. In this case, the context is called constant and the expression remains free, after which it passes into the phraseological category. Lexicography plays an important role in the preservation, improvement and study of phraseological units. Necessary research and practical work have been done in developed countries in this regard. In Uzbek linguistics, our scholars have conducted a linguistic study of phraseological units in various aspects, a lexicographic study of phrases. A dictionary of polysemantic phraseologies has not yet been developed.

When compiling a dictionary, the contextual aspects of the phrases should also be taken into account. Depending on which segment of the speech chain serves as a necessary and sufficient actualizer of the verb, the intro-phrase, phrase, and super-phrasal context differ. Intro is defined by A.V. Kunin as an actualizer of a verb expressed by a word or group of words in a simple or complex sentence in a phrasal context. Phrasal context is a verb actualizer represented by a simple or complex sentence. Super phrasal context is a verb actualizer represented by two or more sentences. The proposed research seeks to identify context types in which the meanings of phraseological units are updated.

## LITERATURE REVIEW

Phraseologism is the recognition of figurative and figurative meanings as differential signs that distinguish integral signs from fixed ones. Phraseologization is not only a linguistic phenomenon,<sup>1</sup> but also a product of the development of the human mind, and should be considered as a linguistic and philosophical phenomenon. Semantic, methodological, grammatical-semantic features of phraseological units prof. Sh.Rakhmatullaev<sup>2</sup>, studied in the researches of A.Mamatov<sup>3</sup>, K.Khakimov<sup>4</sup>, Sh.Almamatova<sup>5</sup>, U.Rashidova. Functional-methodical, usual and occasional functions of phraseological units, pragmatic possibilities in the text were studied by B.Yuldashev and U.Rashidova.

Phraseological context includes situations in which variable combinations of words (their categorical or specific semantics) or non-sentence words act as actualizers of verb values. In the study of phrasal actualizers of this type, the analysis of nominal forms that perform subject-object functions in the verb is of particular importance. Linguists emphasize the special role of the subject-object functions that express the verb internally, emphasizing the objects that are directly “involved” in the action it represents. The semantic analysis of words performing subject-object functions reveals their direct involvement in overcoming the ambiguity of the predicate expressed by verbal phraseology.

In the analysis performed, the semantic reference can come both from the categorical semantics of words performing the functions of subject, object (or subject and object), and from their specific semantics that constitute the lexical series, the model of lexical compatibility. The role of categorical semantics of words in overcoming polysemy should be emphasized. The categorical components of words, explaining the relationship of words in a sentence, allow important words to be grouped into categories or classes that differ in the unit of grammatical activity. It is well known that many lexical and grammatical categories within separate parts of speech are distinguished on the basis of categorical semantic features. These categories may include, in particular, the names of animate or inanimate objects, the names of concrete objects or abstract concepts, the names of persons or non-mahrams, the names of countable or uncountable objects, and so on. The fact that words belong to certain categories within a particular part of speech makes them phraseological semantic variants of the verb in the form of system actualizers.

## RESEARCH METHODOLOGY

The distinction of science at the level of semantic categories and abstract concepts of concrete objects can be shown in the example of the verb to go wrong. In this phrase, the meaning of “to stop work, to get out of work” occurs when the horses that perform the function of the subject

are represented by specific objects that represent mechanisms, devices, and so on. The second meaning of “exit, exit, disagreement” is actualized by horses in abstract semantics.

The analysis of examples shows that the belonging of keywords that act as an object of action to the semantic category of inanimate objects (abstract concepts) means "stay away with respect", while the belonging of keywords to the category of animate objects means "drive (thought), give (feel)", means to hold at arm's length.

In some cases, the distinction between phraseological and semantic variants of a verb is made by grammatical (syntactic or morphological) means.

### Analysis and results

Hence, the verb to rejoice in the sense of "to entertain, to amuse" is used in the absolute sense, and in the sense of "to laugh, to mock someone" is mainly controlled by the addition of the word in the future tense. Phraseological units that express mood also have a polysemantic character. For example, “**Ko'ngli bo'lmadi**” ( **could not dare, or do not want**). In the current era of rising prices, he did not want to leave her homeless. (Author's diss.145p.)

“**...ichi uvishdi**” ( **to pity**). Oychechan bibi's was pitied for the woman who had lost her memory. (Author's diss.145p.) “**...jon berayotib**”( **before dying**) John before dying raised his head and shouted at Malik, the young man who was being taken out of the siege. (Author's diss.145p.) “**...diliga qo'rquv tushib**” ( **to feel fear**). Fear fell on the hearts of the noyans and navkars, some biting the ground and some trembling. (Author's diss.145p.)

“**...hayratdan tang qotdi**” ( **to be astonished**). Gulbegim was astonished. (Author's diss.145p.) “**... xayolini yig'ishtirib olmoq**”( **to keep the coincide**). Before the mother could keep her coincide, the boy began to squirm again. (Author's diss.147p.) “**... yo'l ko'rsatmoq**” ( **to give the direction**) – You are really guiding me and looking for a reward, so you have no other goal. (Author's diss.147p.) “**... bag'riga bosdi**” ( **to hug**) Abdul Mahak hugged him. (Author's diss.148p.) “**...ko'zqirinitashlamoq**” ( **to glance at**). The Sultan glanced at him. (Author's diss.148p.) ...тилга олишарди.

“**...sir boy bermaslik**”( **to keep a secret**). He astonished to the power of Jalaliddin but tried to keep a secret. (Author's diss.150p.)

“**...Joniga oro kirib**” ( **to lessen, to release**). But the moment the hook fell on his neck, he slipped his thumb through the rope. (Author's diss.150p.)

“**...отилиб чикди**” ( **to come out of**). Jalaliddin came out of the tent, then into the side. (Author's diss.150p.)

“**...o'rabolaboshladi**” ( **began to surround**). It began to surround on all four sides. (Author's diss.151p.) ... **to break the curve**. The intensity of the siege was replaced by the intensity of the siege. (Author's diss.151p.)

“ **...esiniyig'ishtiribolmoq**” ( **to regain consciousness**).

Unexpectedly, the young man broke through the barrier until he regained consciousness. (Author's diss.152p.) ... **the flames of rage engulfed him**. His face twisted and his flat face was covered with the flames of anger. (Author's diss.152p.) ... **escaped my clutches**. "Today he

escaped from my clutches," said Haqqan without taking his eyes off the ground. (Author's diss.152 p.) ... I can't catch. I can't catch her tomorrow. (Author's diss.152 p.)

**...ko'ziniolibqochmaydi ( does not take his eyes off).**

Chigatoy does not take his eyes off. (Author's diss.152 p.) ... **without blinking.** He answered without blinking. (Author's diss.152 p.) ... building himself. Chigato sits on the haqaan as he builds a building for himself and speaks. (Author's diss.152 p.) ... **disappointing.** He was annoyed in vain. Disappointed. (Author's diss.153 p.) ... **suppressing his anger a little.** Long live the sultan! He continued, suppressing his anger a little. (Author's diss.153 p.) ... **to capture.** - First I wanted to capture that arrogant Khorezmshah alive. (Author's diss.153 p.)

The mother, the wife, the child, must be captured in full with the harem. (Author's diss.153 p.) ... there was a heavy silence. There was another heavy silence. (Author's diss.153 p.) ... the root of the soul is alive. - The sultanate of Khorezmshahs is broken, but his soul is still alive. (Author's diss.153 p.)

**"...damiichigatushmoq" (... to fall into the trap).** If he surrenders alive, the people will fall into the trap. (Author's diss.153 p.) ... **writing his heart.** Your mother's feast broke the Sultan's heart. (Author's diss.154 p.) ... **heart pounding chest.** "To the river?" He asked, his heart pounding in his chest. Jaloliddin. (Author's diss.154 p.) ... **the last to be mentioned.** Perhaps eternity is the last grace spoken involuntarily in the face of judgment! (Author's diss.154 p.)

**"...qonga to'ldi" ( to get angry).** The sultan's eyes filled with tears and blood. (Author's diss.154 p.) ... **with a glance.** Nurani, who was twenty paces ahead, turned around and said to Abdul Mahak, who was staring at the rock, "Go, dear brother, go." (Author's diss.154 p.) ... **to get out.** "That's where we're going to rest on the rock and go on the road." (Author's diss.154 p.) ... **to shake an entity.** The cold wind grew stronger, and the sound of the waves shook the creature as if it had moved into the Sultan's heart. (Author's diss.156p.)

**"...oyoqqa turg'izdi" (to raise).** Upon receiving this news, the sultan immediately raised his bar army. (Author's diss.156 p.) **"... yo'l oldi" ( to be going to).** He and his men marched to the left in the direction of the coming Kutku Noyn army. (Author's diss.156 p.)

**"...ko'ziorqasida" (behind the eyes, to worry).** Behind his eyes was his mother's wife, who was still being put on the ship, with her children, on the side where her mind was crawling. (Author's diss.156 p.) ... **full of hearty whey.** Oychechan Bibi tries to calm down her daughter-in-law and relatives, but her heart is full of whey, and yet she keeps the secret and tries to be patient. (Author's diss.156p.) (Author's diss.156 p.)

**"...ming joyidan tilindi" (was torn from a thousand places).** The mother's heart was torn in a thousand places. (Author's diss.157 p.) ... **disappeared.** Jaloliddin disappeared from the hill without being caught by the guards behind him. (Author's diss.157 p.) ... **cracked.** Karabayir broke through the first siege. (Author's diss.157 p.) ... **thrown at him.** The river is gushing. He was screaming. It was thrown at him as if on a ship. (Author's diss.157 p.) ... **jumping over the bow head.** Karabayir jumps over the slope and rushes to the shore.

**"...o'zigakelmoq" (to get back, to recover).**



Gulbegim Bonu, whose son was left on the shore, still cannot recover. (Author's diss.159 p.) ... **at the tip of the tongue.** Oychechan bibi wanted to say something to the bride, but the words on the tip of her tongue remained under the roar of the waves.(Author's diss.159 p.)

**"...ko'z ochibko'rmoq" (to love, to like).**

On the shore, where he was on a wavy ship and his imagination was getting farther and farther away, his love was with the sultan, with his only son, Jalaliddin.(Author's diss.159 p.)

**"...ko'zgatashlandi" (to be seemed).** Karabayir was seen leading the qibla to the shore.(Author's diss.160 p.)

**"...girdob og'zigatutadi"(to catch the whirlwind of the ship).**The waves catch the whirlwind of the ship, which is rolling on its shoulders Тўлқинлар ўз елкаларига чархпалак қилиб келётган кемани гирдоб оғзига тутди.(Author's diss.160 p.)

**"...ko'zdan g'yib bo'ldi" (to disappear).** It wakes up and disappears(Author's diss.160 p.)

He needed the head of Genghis, who had ruined his country, his people, his homeland, his parents, his children, his wife, his brothers. (Author's diss.160 p.) Probably for the first time in his life, Genghis Khan became envious and said to his sons: "If one have a son, let it be like a Jalaliddin"!(Author's diss.162 p.)

**"...ko'zdanqochirmang" (to pay attention, to make overlook).** No matter where you go in the world, don't overlook it.(Author's diss.162 p.)

**"...ichidan zil ketdi" (to trouble).** Ibn Hojib was troubled.(Author's diss.165 p.)

**"...ko'z-quloqbo'lmoq" ( to take care of).** The reason he found out that the war ended in Genghis Khan's favor was because he was standing by the river. Suddenly a huge wave hit the wrists of the hump and tore off his nose, and although the minister did not try to swim, the river began to pull him to his knees.(Author's diss.165 p.)

**"...ko'zitushibqoldi" (to catch a sight).** Then he caught sight of the fast-flowing boy, and longed for him.(Author's diss.165 p.)

**"... xayoliga ham kelmagan"(never imagined).** It was unthinkable for Shamsulmulk to take the burduk from the boy.(Author's diss.166 p.)

**"...bosh ustlarida" (wearings, clothes)** Suddenly a group of blacks appeared on their body.(Author's diss.166 p.)

**"...quloqtutmoqlik" (to listen, to obey)**It is our duty to listen to and follow the word of the Almighty.(Author's diss.166 p.)

**"...g'azabiqattiq" (the anger is intense).** He was well aware of the severity of Eltutmish's anger.(Author's diss.166 p.)

**"...gapning indalosini"(The motive of speech).**But Ibn Hijib can be told the motive of the sentence, which the Cubans know... (Author's diss.165 p.)

**...qo'lkermoq(... to be able to).** This will come in handy on this way.(Author's diss.165 p.)

The above examples from "Sultan Jalaliddin" novel are used in two or more senses.

We can distinguish polysemantic phraseologies as a special type of expression in the occasional context, which is usually understood as the addition and deformation of the verb. The inclusion of variable components in the verb structure is also used to make other periodic changes, in particular, to strengthen, improve, or weaken the verb value. This functional load of occasional “novelties” can in some cases eliminate any meaning that is potentially specific to the verb due to the logical incompatibility of the meaning of a particular qualification with the phraseological meaning.

Sentence elements that contain phraseological units are in some cases contextually inadequate and cannot understand the true meaning of a verb. In such cases, the phrasal context can act as a necessary and sufficient actualizer of the verb.

**Conclusion and recommendation.** Hence, by studying the contextual use of the polysemantic verb, we can draw the following conclusions:

- 1) Due to the structural and semantic features of the verb, they do not always have sufficient descriptive power to reveal the content of the verb. This implies the need to interconnect the so-called phraseological context of the verb and the context;
- 2) It serves as a means of emphasizing and updating contextual values in relation to polysemy. The context realizes and emphasizes the shadows of single verb values, as well as the individual values of a multi-valued verb.

#### REFERENCES

1. Berdiyurov H., Yuldashev B. Bibliographic index on Uzbek phraseology.- Samarkand, 1977.
2. Rahmatullaev Sh. Phraseology with lexicology. Modern Uzbek literary language. -Tashkent, 1992, -P.49-186.
3. Mamatov A.E. Semantic and stylistic features of emotional and evaluative phraseological units of the Uzbek language. -Abstract of PhD diss. of author. -Tashkent, 1988.
4. Hakimov Q.M. Necessary combinations of simple phraseological idioms in Uzbek language. – Abstract of PhD diss. of author -Tashkent, 1994.
5. Almamatova Sh. Component analysis of Uzbek phrases. - Tashkent, 2008. -23 p.
6. Rashidova U. Semantic-pragmatic analysis of somatic expressions in Uzbek language (on the example of expressions with eye, hand and heart components): Ph.D. (PhD) diss...of author. -Samarkand, 2018. –51 p.

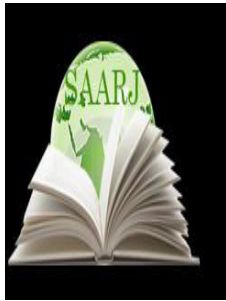

**ACADEMICIA**  
**An International**  
**Multidisciplinary**  
**Research Journal**  
 (Double Blind Refereed & Peer Reviewed Journal)

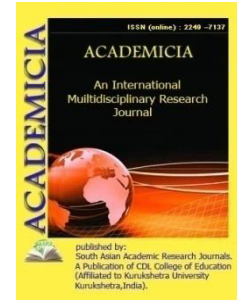

**DOI: 10.5958/2249-7137.2021.01882.6**

**STRUCTURAL CHANGES IN HIGHER EDUCATION IN THE PROCESS  
 OF FORMATION OF THE THIRD RENAISSANCE FOUNDATION**

**Khakimov Akbar Anvarovich\***

\*Independent PhD candidate,  
 UZBEKISTAN

**ABSTRACT**

*This article reflects the results of reforms aimed at improving the quality of higher education in the Republic of Uzbekistan (its goals and objectives, criteria), training of qualified specialists that will contribute to the economic growth of the country, as well as future work. One of the most pressing issues in this area has been related to the very low percentage of graduates with higher education coverage. For example, in 2008-2009, 286.2 thousand students studied in 63 higher education institutions of the country in various fields. The foundation of the Third Renaissance is being laid. Efforts in this regard are of historical significance. Years pass, times change, and the good deeds done today will undoubtedly arouse great pride in the hearts of future generations. The foundation of the Third Renaissance is being laid. Efforts in this regard are of historical significance. Years pass, times change, and the good deeds done today will undoubtedly arouse great pride in the hearts of future generations.*

**KEYWORDS:** *Renaissance, Intellectual Development, Innovative Activity, Modern Personnel, Credit Module, Information Platform.*

**INTRODUCTION**

Alexis Carrell, a world-renowned French scientist and Nobel laureate, said, "Science has changed the world, it is the root cause of the greatest revolutions humanity has ever experienced." Indeed, man's understanding of the universe, his discoveries, his progress, and his vision of the future are all directly connected with science and education. This is something you have never had to develop. If we look at history, we come across the names of many scientists and fuzalas who made great contributions to world civilization. While acknowledging the place and status of each, it can be said that the share of great geniuses who lived in the Central Asian region in world civilization is incomparable. We remember them with two Renaissance periods. In particular, during the first Renaissance, dozens of great scholars such as Muhammad

Khorezmi, Ahmad Fergani, Abu Rayhan Beruni, Abu Ali ibn Sino, Mahmud Zamakhshari emerged. Their world-class scientific and creative discoveries have had a huge impact on the development of mankind. Great thinkers such as Imam Bukhari, Imam Termezi, Imam Moturidi, Burhaniddin Marghinani, Abul Mu'in Nasafi, who grew up in our homeland during this period, which is recognized in historical sources as the "golden age of Islamic culture", became famous throughout the Muslim world.

The great empire founded by Sahibkiran Amir Temur in the fifteenth century and continued by his worthy descendants started the second Renaissance in our country. Our great-grandfather created great opportunities for the development of science and culture, paid special attention to scientists, art critics, writers and poets. During this period, such great scholars as Rumi, Mirzo Ulugbek, Giyosiddin Kashi, Ali Kushchi, Lutfi, Sakkoki, Hafiz Khorezmi, Abdurahmon Jami, Alisher Navoi, Babur Mirzo, and other great poets and thinkers appeared. The fame of such historians as Sharafiddin Ali Yazdi, Mirkhand, Khandamir, artists such as Mahmud Muzahhib, Kamoliddin Behzod, many calligraphers and musicians, musicologists and architects spread all over the world.

We should be proud of them no matter what. But pride alone is not the end of the matter. We must also be able to show that we are a generation worthy of great ancestors. Therefore, in the new period of development of Uzbekistan, we have a firm and noble goal - to achieve the third Renaissance as a strategic task. The development of pre-school and school education, the system of higher and secondary special education and scientific and cultural institutions will serve as an important basis for the third Renaissance.

Let us continue our thinking directly with the higher education system and the process of reform in it. It should be noted that today a large-scale work is being carried out to further improve the educational process in higher education institutions of the country. In particular, great attention is paid to the development of integration of science, education and industry in order to accelerate intellectual development, train competitive personnel, effectively organize scientific and innovative activities and strengthen international cooperation.

One of the most pressing issues in this area has been related to the very low percentage of graduates with higher education coverage. For example, in 2008-2009, 286.2 thousand students studied in 63 higher education institutions of the country in various fields. In 2016, the number of universities in the country reached 77, and the number of students approached about 300 thousand. In particular, the number of students studying in Samarkand (5.2 thousand), Kashkadarya, Jizzakh (3.3 thousand) and Andijan (3.1 thousand) regions has increased. However, even then, the overall coverage rate was only 9 percent, which did not satisfy us.

In order to bring education to a new level, radically improve the quality of training highly qualified personnel for the labor market, strengthen the material and technical base of higher education institutions, as well as retraining and advanced training of teachers The program of integrated development of the higher education system for 2017-2021 was approved by the resolution "On measures to improve the quality of education." According to the developed program, the number of higher education institutions increased by 26 and the number of students by 62.5 thousand a year.

To date, the number of universities in the country has reached 141, branches of 26 foreign universities have been opened. More than 590,000 students study in them in various fields of education. The number of state grants has increased by 26,000 to 47,000.

In the same year, great opportunities were created for 182,000 young people to study at higher education institutions, and it is planned to triple the quota for admission to higher education in the next five years. In other words, the total coverage of young people in higher education has reached 28%.

At the same time, the number of professors and teachers of higher education institutions increased by 6,000 compared to 2016 and reached 30,000. In particular, in Surkhandarya (2.2 times), Khorezm (1.7 times), Andijan, Kashkadarya and Syrdarya (1.6 times) regions, the number of professors and teachers has increased significantly.

In order to determine the priorities of systemic reform of higher education in the Republic of Uzbekistan, to raise the process of training modern independent thinking personnel with modern knowledge and high moral qualities, to modernize higher education, to develop social and economic sectors based on advanced educational technologies On October 8, 2019, the Decree of the President of the Republic of Uzbekistan "On approval of the Concept of development of the higher education system of the Republic of Uzbekistan until 2030" was adopted.

According to the document, the development of integration of science, education and industry is aimed at accelerating intellectual development, training competitive personnel, effective organization of scientific and innovative activities and strengthening international cooperation.

At the same time, due to the implementation of the concept of development of the higher education system until 2030:

development of public-private partnership in the field, increase the coverage of higher education to at least 50% on the basis of the organization of higher education institutions in the regions and the creation of a healthy competitive environment in the field;

increase the scientific potential of higher education institutions to 70%;

gradual transition of the educational process in higher education institutions to the credit-module system;

Accelerate the creation of national e-learning resources, organize the translation of foreign e-learning resources, increase the share of e-resources in the educational process;

inclusion of higher education institutions in the country in the list of the first 1,000 in the ranking of internationally recognized organizations;

Transformation of the higher education system of Uzbekistan into a "hub" for the implementation of international educational programs in Central Asia;

lectures and workshops, which allow online observation and mastering of seminars, as well as their implementation in the implementation of electronic information platforms, individualization of educational processes on the basis of digital technologies, development of distance learning services, "blended learning" and wide implementation of "flipped classroom" technology;

gradual introduction of the concept of interdependence of education, science, innovation and commercialization of research results;

establishment of technoparks, foresight, technology transfer, startup, accelerator centers, bringing them to the level of scientific and practical institutions that study and forecast the development of industries;

creation of effective mechanisms for regular provision of educational and scientific processes with educational and laboratory equipment, as well as laboratory materials (reagents, components, biological materials, etc.), modern software products;

increase the level of higher education coverage of people with disabilities;

the investment attractiveness of higher education will be increased, the attraction of foreign education and science technologies will be achieved.

All this serves to raise the educational process to a new level of quality.

In turn, the work on the implementation of the set tasks is being carried out at a rapid pace. In particular, in accordance with the Decree of the President of the Republic of Uzbekistan No. PF-6155 of February 3, 2021 and the Resolution of the President of the Republic of Uzbekistan No. PQ-4749 of June 12, 2020, admission rates for women on the basis of state grants It is noteworthy that the number of state grants for education has doubled. For example, during the 2019/2020 academic year, the level of education of women in higher education institutions increased from 38% to 46%.

Also, on July 30 this year, the President of the Republic of Uzbekistan "On measures to further expand educational opportunities in higher education institutions" created favorable conditions for young people to study on a fee-for-service basis - a new system of educational loans . In particular, at least 1 trillion soums will be allocated in 2021, and the main part of the educational loan will be repaid within 7 years after the end of the official term of study.

In order to create more convenience for students in higher education institutions of the Republic of Uzbekistan, the Government adopted Resolution No. 563 of September 9, 2021 "On measures to increase the coverage of students in higher education institutions of the Republic" for the construction of modern student housing with all amenities was made. According to this document, in 2022-2025, 228 student dormitories will be built on 68.4 hectares of land for 91.2 thousand students in 85 higher education institutions.

In general, great efforts are being made to improve not only the level of coverage of higher education, but also the quality of education, spiritual and cultural level of young people. The foundation of the Third Renaissance is being laid. Efforts in this regard are of historical significance. Years pass, times change, and the good deeds done today will undoubtedly arouse great pride in the hearts of future generations. Along with the first and second Renaissance periods, they proudly mention the Third Renaissance period and strive to be worthy of it. We will achieve that.

#### **REFERENCES:**

1. Decrees, resolutions of the President of the Republic of Uzbekistan, resolutions of the Cabinet of Ministers, <https://lex.uz>



2. Press briefing of the President of the Republic of Uzbekistan on 17.08.2021 "New Uzbekistan is becoming a country of democratic change, broad opportunities and practical work." <https://president.uz/uz/lists/view/4547>
3. Open data portal of the Republic of Uzbekistan, <https://data.gov.uz/uz>
4. Open database of the Statistics Committee of the Republic of Uzbekistan on the website [www.stat.uz](http://www.stat.uz).
5. Open database of the Ministry of Higher and Secondary Special Education of the Republic of Uzbekistan on the website <https://edu.uz/uz/pages/sss>.
6. UP Umurzakov, "Reforms of the education system will lay the foundation for a new Renaissance in Uzbekistan", People's Word newspaper, <https://xs.uz/uzkr/post/talim-tizimi-islohotlari-ozbekistanda-naki-ujgonish-davri-pojdevorini-creates>

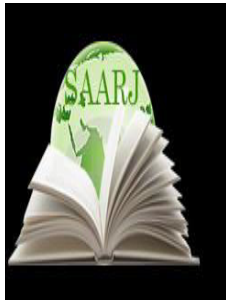

**ACADEMICIA**  
**An International**  
**Multidisciplinary**  
**Research Journal**  
 (Double Blind Refereed & Peer Reviewed Journal)

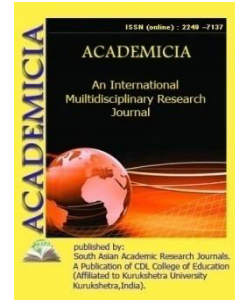

**DOI: 10.5958/2249-7137.2021.01883.8**

## FEATURES OF THE COURSE OF ARTERIAL HYPERTENSION ASSOCIATED WITH METABOLIC SYNDROME

**Axmedova Gulmira Ixtiyarovna\***; **Juraeva Khafiza Iskandarovna\*\***

<sup>1,2</sup>Bukhara State Medical Institute named after Abu Ali ibn Sino. Bukhara,  
 Republic of UZBEKISTAN

### ABSTRACT

*The article presents a review of the literature on metabolic syndrome, the dynamics of ideas, the relationship between insulin resistance and cardiovascular diseases; arterial hypertension as a component of metabolic syndrome, features of its development and course; features of hemodynamics and damage to target organs in arterial hypertension associated with metabolic syndrome. The second mechanism is the effect of hyperglycemia on the expression of the angiotensinogen gene in the renal tissue under IR conditions, which leads to increased renal hypersympathicotonia. The presence of a link between hypertension, obesity, impaired carbohydrate metabolism and gout was noted at the beginning of the last century by GF Lang [5] and E. Kylin [6], and subsequently by A. L. Myasnikov, D. M. Grotel and M.P. Konchalovsky. Thus, under conditions of chronic GI, active lipolysis occurs in fat stores and an increase in the concentration of free fatty acids (FFA) in the blood [12], an increase in the thickness of the muscular layer of blood vessels and myocardial hypertrophy, stimulation of the SNS, an increase in reabsorption and a decrease in sodium excretion and water [16], weakening of the vasodilating properties of insulin due to a deficiency in the production of nitric oxide [15].*

**KEYWORDS:** Syndrome, Hyperglycemia, Hypertension

### INTRODUCTION

**The urgency of the problem.** Cardiovascular disease (CVD) remains the most serious public health problem in many countries around the world. Experts from the World Health Organization (WHO) predict a further increase in CVD, as well as mortality from these diseases, in both developed and developing countries, due to changes in demographic indicators (aging of the population), an increase in noncommunicable diseases (NCDs) and characteristics and lifestyles.

According to the results of the Centers for Disease Control and Prevention, such a high prevalence of CVD, covering all countries and continents, leads to a decrease in the frequency of average life expectancy by 10 years, as well as to long-term disability of the adult population and requires colossal economic costs.

**Target.** To study the features of the course of arterial hypertension associated with metabolic syndrome on the basis of the results of clinical studies.

## RESULTS AND DISCUSSIONS

### **Metabolic syndrome, dynamics of ideas, connection of insulin resistance with cardiovascular diseases**

In the 21st century, cardiovascular diseases (CVD) associated with atherosclerosis (arterial hypertension, myocardial infarction, stroke) still occupy the first place among the main causes of death and disability [1]. Morbidity and mortality from ischemic heart disease (IHD), complications of arterial hypertension (AH) are associated with the presence and level of risk factors for their development [2]. Among them, the most significant are AH, dyslipidemia, obesity, diabetes mellitus (DM) and hyperinsulinemia (GI), which tend to combine [3]. The incidence of sudden death and the development of myocardial infarction, according to the PROKAM study, increases with a combination of two or more CVD risk factors [4].

The presence of a link between hypertension, obesity, impaired carbohydrate metabolism and gout was noted at the beginning of the last century by GF Lang [5] and E. Kylin [6], and subsequently by A. L. Myasnikov, D. M. Grotel and M.P. Konchalovsky. In 1956 J. Vaque noted an increased incidence of CVD in patients with abdominal obesity (AO) [23], and E. Gamus [9] in 1966 called the combination of these factors "metabolic trisynndrome". In 1989, N. M. Kaplan called the combination of AO, impaired glucose tolerance (IGT), hypertriglyceridemia, and hypertension a "lethal quart", meaning the extreme atherogenicity of this combination [14].

In 1988 G. Reaven [22] proposed the term "syndrome X" to denote a cluster of metabolic factors accumulating in one person: hypertension, dyslipidemia (an increase in the concentration of triglycerides (TG) in the blood, associated with a decrease in the level of high-density lipoproteins (HDL), IR and SD type II. Later, AO was added to these factors [22]. Since 1988, the MS criteria have undergone significant changes. A number of researchers have supplemented the concept of MS with new characteristics, such as hyperuricemia, microalbuminuria (MAU), left ventricular hypertrophy (LVH), hyperfibrinogenemia, ovarian sclerocystosis, etc. [14, 15].

Over the past decades, MS has come to be called the "epidemic of highly developed countries" due to its high prevalence. In the world, among the population over 30 years of age, its prevalence reaches 15–25% [12], in Russia among patients with hypertension - up to 74%, with IGT and diabetes mellitus - up to 90% [18].

In the classic sense according to the International Diabetes Federation metabolic syndrome involves a combination of AO, IR, hyperglycemia, dyslipidemias, hypertension, disorders of the hemostasis system and chronic subclinical inflammation [18], which are based on complex neurohumoral and hormonal disorders [11].

IR is understood as a violation of insulin-mediated glucose utilization in organs (skeletal muscles and myocardium, adipose tissue and liver), where pathophysiological changes depend on the

nature of insulin action in a particular case [6]. At the same time, compensatory GI occurs to maintain the concentration of glucose in the blood at a normal level. Subsequently, NTG develops with the formation of MS. Until the end, the reason for the development of IR remains unclear. Even healthy people, insulin sensitivity can fluctuate widely, due to changing 3-4 times [25].

The causes of IR can be a mutation of the coding gene (pre-receptor mechanism), autoimmunization with the production of antibodies to insulin and insulin receptors, a change in the insulin molecule, an increase in the number of insulin receptors, a change in their structure and affinity, insulin response [25], as well as the mechanisms of postreceptor action of insulin (change in the structure of the glucose transport protein GLUT [15], hormonal and metabolic factors).

It is known that insulin is an anabolic hormone, the main function of which is the utilization of glucose and the synthesis of glycogen. But its role in the regulation of metabolism goes beyond just the regulation of blood glucose levels. Insulin receptors are found in different tissues:

- ✓ skeletal muscles and myocardium, where glucose is utilized;
- ✓ adipocytes of adipose tissue, where, under the influence of insulin, lipolysis is inhibited;
- ✓ vascular smooth muscle cells, which proliferate with GI vascular endothelium, where insulin affects the synthesis of prostaglandins, nitric oxide, bradykinin (vasodilating effect);
- ✓ the kidneys, where insulin, acting on the renal tubules, enhances the reabsorption of sodium and water;
- ✓ sympathetic nervous system (SNS) - insulin stimulates the SNS, increasing cardiac output and peripheral vasospasm.

Thus, under conditions of chronic GI, active lipolysis occurs in fat stores and an increase in the concentration of free fatty acids (FFA) in the blood [12], an increase in the thickness of the muscular layer of blood vessels and myocardial hypertrophy, stimulation of the SNS, an increase in reabsorption and a decrease in sodium excretion and water [16], weakening of the vasodilating properties of insulin due to a deficiency in the production of nitric oxide [15]. Therefore, the presence of IR is closely associated with the risk of CVD associated with atherosclerosis: hypertension, coronary artery disease, stroke, which has been proven in numerous studies [22, 23].

### **Arterial hypertension as a component of metabolic syndrome, features of its development and course**

Hypertension in MS is closely related to its other components. In 1985 M. Modan et al. in patients with hypertension, a higher level of insulin in the blood was revealed compared to normotonic. This relationship did not depend on the presence of obesity and IGT [19]. Later, E. Ferrannini proved the same with the help of the "clamp" test [8]. Patients with hypertension, on average, utilize 40% less glucose than those with normal blood pressure (BP) [10]. The relationship between AH and GI was independently confirmed by other researchers [15].

According to E. Ferrannini, there are three possible hypotheses that can explain the relationship between IR and AH. It is assumed that IR causes the development of AH, AH is the cause of IR,

and it is also possible that IR and AH are parallel consequences of a common cause [8]. The ARIC study found that GI was associated with hypertension and was its predictor when combined with metabolic disorders [23]. Other experimental studies have shown that a constant increase in blood pressure is accompanied by a decrease in peripheral blood flow and endothelial dysfunction, which can lead to a decrease in the sensitivity of skeletal muscles to insulin and the development of IR [12].

The assumption that IR is the result of hypertension seems unlikely [14]. In particular, it was shown that symptomatic hypertension is not accompanied by IR, and correction of blood pressure does not always lead to a decrease in IR [10].

It was also noted that AH and IR were most consistently observed in individuals with AO [15]. Back in 1956, J. Vaque drew attention to the relationship between excess body weight and the nature of fat distribution with the possibility of developing hypertension, diabetes mellitus, atherosclerosis and gout [23]. The relationship between hypertension and obesity has been confirmed in numerous studies. According to the Framingham study, newly diagnosed hypertension in 70% of cases is combined with obesity or overweight [16].

The Gothenburg epidemiological study not only confirmed the role of obesity as a risk factor for CVD, but also demonstrated their dependence on the type of obesity [17]. According to V.A. Almazov, in the group of patients with AH, AH and type II diabetes were more common than in the group with gluteofemoral obesity [18, 19]. The presence of abdominal obesity plays an important role in the association of hypertension and IR [15].

Thus, to date, there is no common understanding of both the etiopathogenesis of AH associated with MS, and the problem of the cause-and-effect relationship between AH and IR [14]. But there is no doubt that the pathogenesis of hypertension in MS is based on IR and the compensatory GI in combination with concomitant metabolic disorders [2]. Chronic GI affects blood pressure through the following mechanisms:

stimulates the activity of the sympathetic-adrenal system (SAS), which leads to an increase in vascular tone, including renal hypersympathicotonia [19,20];

- stimulates the activity of the renin-angiotensin-aldosterone system (RAAS) [7]. Studies show that when AH is combined with IR, the activity of angiotensin-converting enzyme (ACE) is significantly higher, than in patients with hypertension without IR [10];

- blocks transmembrane ion exchange mechanisms (Na-K-ATPases and Ca-Mg-ATPase), increasing the content of intracellular sodium and calcium and decreasing the potassium content, which leads to increased sensitivity of the vascular wall to pressor effects [14, 17, 18];

increases the reabsorption of sodium in the proximal and distal tubules of the nephron, contributing to fluid retention, the development of hypervolemia and an increase in sodium and calcium in the walls of blood vessels [3,9];

- stimulates the proliferation of smooth muscle cells of the vascular wall due to direct and indirect mitogenic action, leading to narrowing of arterioles and an increase in systemic vascular resistance [7, 18].

Two more mechanisms are considered that are of great importance in the formation of hypertension in MS. The first is associated with leptin, a hormone synthesized in adipocytes of adipose tissue, which enhances the activity of SNS [20].

The second mechanism is the effect of hyperglycemia on the expression of the angiotensinogen gene in the renal tissue under IR conditions, which leads to increased renal hypersympathicotonia. Normally, insulin suppresses the stimulating effect of hyperglycemia on the expression of the angiotensinogen gene in the cells of the proximal renal tubules and prevents an increase in its secretion. With IR, insulin suppression of glucose-stimulated expression of the angiotensinogen gene in the cells of the proximal renal tubules does not occur, the gene expression is disinhibited, and the secretion of angiotensinogen increases [21].

Apparently, it is this mechanism that underlies the increase in the production of angiotensin II (AT II) in the glomerular and tubular cells of the renal tissue under the influence of hyperglycemia. The effect of AT II on AT1 receptors leads to an increase in renal hypersympathicotonia [12].

Under the influence of the above mechanisms, a constant increase in blood pressure is accompanied by a decrease in peripheral blood flow and endothelial dysfunction according to the principle of feedback, which enhances the phenomenon of IR. All this is more pronounced in hypertension associated with MS. First of all, the so-called insulin-requiring tissues - muscle (including myocardium), blood vessels - suffer.

Vessels are one of the main target organs that are affected in various diseases. The properties of arteries are impaired in hypertension, MS, diabetes mellitus, atherosclerosis, etc. Vascular lesion in hypertension is characterized by increased rigidity and stiffness, decreased elasticity of the wall of large arteries and, as a consequence, increased systolic and PAP, which accelerates arterial damage. An increase in the rigidity of the vascular wall occurs as a result of the rapid proliferation of vascular smooth muscle cells, elastic fibers and the accumulation of the extracellular matrix. This leads to an increase in the thickness of the intima-media layer and a decrease in the lumen of the vessel, to vascular remodeling [24].

A complex of neurohumoral factors (RAAS, SNS, vascular endothelium) is also involved in the remodeling process.

The process of remodeling involves the microvasculature, which leads to an increase in OPSS [13]. In MS, the process of vascular wall remodeling, in addition to hemodynamic and neurohumoral factors, is exacerbated by GI and IR [17, 18].

Based on the foregoing, it can be concluded that in MS due to a combination of disorders of various types of metabolism, the rigidity of the arteries increases and cardiovascular risks increase.

An increase in arterial stiffness, leading to an increase in SBP, PAP and OPSS, increases the load on the left ventricle. Hemodynamic load in combination with the specific effect of GI and IR on cardiomyocytes leads to LVH, which is one of the important manifestations of hypertension and is the result of adaptation of the heart to an increase in afterload [12].

Having a compensatory character at the beginning of the disease, later on it acquires a pathological significance and is an independent risk factor for coronary artery disease, sudden



death and heart failure [13]. In particular, thickening left ventricular wall by 1 mm increases the risk of fatal complications 7 times [21].

The issue of the association of hypertension and various components of MS with LVH has been insufficiently studied, and the available information on the role of insulin in the development of LVH is contradictory [15,20]. According to some authors, AH and obesity as components of MS are the leading determinants of LVH [14], which is apparently due to GI [21]. In other studies, obesity is considered the dominant factor regardless of fat distribution [17]. A predisposition to hypertension, obesity and LVH is also not excluded [24].

A number of studies have also shown that AH in MS is accompanied by more pronounced LVH than AH proceeding against the background of normal insulin metabolism [10, 14, 18], and LM Resnick even isolates LVH as a separate component of "generalized cardiovascular metabolic disease" [19]. The kidneys are one of the most vulnerable organs, both primary and secondary. AH is one of the main causes of end-stage chronic renal failure in 10–30% of patients [20].

Kidney damage in hypertension is manifold. An increase in systemic blood pressure is accompanied by an increase in pressure in the capillaries of the glomeruli, which leads to increased filtration of protein through the basement membrane, damage to the endothelium, and the release of cytokines and other mediators. As a result, this leads to the replacement of normal renal tissue with fibrous

In MS, kidney involvement, as well as damage to other target organs, is primarily associated with the action of metabolic disorders - IR, AO, hyperlipidemia, and hypertension. The initial changes in the kidneys are asymptomatic. The earliest marker of kidney damage (at the stage of functional disorders) and an unfavorable prognostic sign is MAU (urinary albumin excretion from 20-30 to 300 mg/day). It is a factor reflecting endothelial dysfunction and damage to the vascular system in general [27].

Some researchers consider the occurrence of MAU as an event of critical importance, indicating generalized damage to the vascular system and the progression of renal failure [22, 23].

MAU is more often observed in patients with a predominant increase in DBP, lack of adequate decrease in blood pressure at night, elevated PAP and BMI [12, 20, 26], LVH and biochemical signs of MS.

GI and IR are important metabolic factors of kidney damage, which are realized through specific mechanisms [22]:

- non-enzymatic glycation of renal membrane proteins, which disrupts their structure and function;
- direct glucotoxic effect through the activation of protein kinase C, which regulates vascular permeability, contractility, cell proliferation processes and the activity of tissue growth factors;
- activation of the formation of free radicals that have a cytotoxic effect;

violation of the synthesis of heparan sulfate, a decrease in the content of which leads to the loss of the basement membrane of the most important function

- the change of selectivity, which is accompanied by the appearance of MAU, and further with the progression of the process and proteinuria. Intracellular hyperglycemia plays a certain role

[23]. Another powerful nephrotoxic factor is hyperlipidemia, which promotes the development of nephrosclerosis similar to the mechanism of vascular atherosclerosis formation (structural similarity of mesangial and smooth muscle cells of arteries, rich receptor apparatus of LDL, oxidized LDL in both cases) [22].

Overweight, namely AO, also predisposes to the development of MAU. In the population study MONICA, it was found that AO is independent, including from other components of MS, as a predictor of MAU [23].

At the same time, MAU has a local toxic effect, leading to the development of aseptic inflammation. In the course of its development, the local synthesis of AT II is stimulated, the excess of which leads to an even greater spasm of the carrying artery, an even greater ischemia of the renal filter and, as a consequence, to an even greater loss of protein through the renal filter[28].

Thus, the multiple but common mechanisms underlying the development of MS lead to a more severe course of hypertension and damage to target organs. Given the close relationship between hypertension and target organ damage in MS, early diagnosis of such a combination will make it possible to identify patients with the most serious prognosis in the general population for a differentiated approach to treatment.

## BIBLIOGRAPHY

1. Assman, G. The Prospective Cardiovascular munster Study: prevalence and prognostic significance of hyperlipidemia in men with systemic hypertension / G. Assman // *Am. J. Cardiol.* – 1987. – Vol. 59. – P. 96–17
2. American Diabetes Association. Consensus of the conference on insulin resistance (November 5-6, 1997) // *International Medical Journal.* 1999. - No. 1. - P. 66–70.
3. Batrak, G.A. Features of carbohydrate metabolism disorders in metabolic personal syndrome / G.A. Little farmhand // *Cardiovascular therapy and prevention.* - 2019. - T. 18, Special issue. - S. 27-28.
4. Batrak, G.A. Risk factors for the development of metabolic syndrome in patients with pre-obesity / G.A. Little farmhand // *Cardiovascular therapy and prevention.* - 2019. - T. 18, Special issue. - S. 28-29.
5. Belyaeva, O.D. Metabolic syndrome in patients with abdominal obesity: clinical and molecular genetic aspects: author. dis. ... Dr. med. Sciences: 14.01.05 / Belyaeva Olga Dmitrievna. - SPb., 2011. -- 35 p.
6. Caro, F. Jose. Insulin resistance in obese and nonobese man / F. Jose Caro // *The J. of Clin.Endocrinol.andMetabol.* – 1991. – № 73. – P. 691–695.
7. Denisenko, M.N. Features of peripheral vascular lesions in patients with essential hypertension / M.N. Denisenko, V.V. Gengel, I.I. Shaposhnik // *Medicine.* - 2016. - No. 2. - S. 33-36.
8. Ferrannini, E. Insulin resistance, hyperinsulinemia and blood pressure: role of age and obesity. European group for the study of Insulin Resistance (EGIR) / E. Ferrannini, A. Natali, B. Capaldo // *Hypertension.* – 1997. – № 7. – P. 10–13.

9. Gamus, J. P. Goutte, Diabete, hyperlipemieuntrisyntronmetabolique / J. P. Gamus //Rev. Rum. – 1966. – № 33. – P. 10.
10. Haffener, P. A. Prospective analysis of the insulin-resistance syndrome (Syndrome X) /P. A. Haffener, R. A. Valder, H. P. Hazuda // Diabetes. – 1992. – № 41. – P. 715–22.
11. Henefeld, M. Das metabolische Syndrome / M. Henefeld, W. Leonhardt // Deutsch.Ges. Wes. – 1980. – № 36. – P. 545–51.
12. Juraeva Kh.I.Frequency of meeting the main components of the metabolic syndrome during disturbance of different phases of glyceimic curve/Badridinova B.K., Kadirov B.S., Majidova M.A., Yakhyaeva Kh.Sh., Negmatullaeva M.A., Amonov M.K//ACADEMICIA:AnInternational Multidisciplinary Research Journal.2019 No. 1. - P. 80 - 85.
13. Juraeva Kh.I., Badridinova B.K., Kadirov B.S.Prevalence and state of treat-ment of arterial hypertension according to questionnaire data.//Electronic scien-tific journal "Biology and Integrative Medicine". - 2017. - No. 3. - P. 78 - 85.
14. Kaplan, N. M. The deadly quartet: Upper body obesity, glucose intolerance, hypertriglyceridemia, and hypertension / N. M. Kaplan // Arch. Intern. Med. – 1989.– № 149. –P. 1514–1520.
15. Kobalava, J.D. Arterial hypertension in the XXI century: achievements, problems, prospects / Zh.D. Kobalava, Yu.V. Kotovskaya. - M.: Publishing house "Bionica Media", 2013. - 272 p.
16. Kylin, E. Studienuber das hypertonie, hypeglykamie, hyperurikamieSyndrom /E. Kylin // Z. Inn. Med. – 1923.– № 7. – P. 105–112.
17. Merkulov, V.A. Patients with arterial hypertension, metabolicskim syndrome and type 2 diabetes mellitus / V.A. Merkulov, A.N. Vasiliev // Reference book of the outpatient doctor. - 2014. - No. 12. - S. 31-33.
18. Metabolic syndrome / IE Chazova, VB Mychka, EF Dorodneva [et al.] // Ter. archive. - 2002. - No. 10. - P. 7–12
19. Modan, M.Hyperinsulinemia: a link between hypertension, obesity and glucose intolerance/ M. Modan, H. Halkin, S. Almog // J. Clin. Invest. – 1985. – № 75. –P. 809–817.
20. Oganov, R.G. Ischemicheartdisease / R.G. Oganov, Yu.M. Pozdnyakov, V.S. Volkov. - M.: Synergy, 2002. - pp. 7–20, 126–130.
21. Prevention of coronary heart disease in clinical practice. Recommendations of the second joint task forse of European and other societies on coronary prevention // Eur. Heart J. – 1998. – № 19. – P. 1434–1503.
22. Reaven, G. M. Role of insulin resistance in human disease / G. M. Reaven // Diabet. –1988. – P. 1595–1607.
23. Vague, T.The degree of masculine differentiation of obesities. A factor determining predisposition to diabetes, atherosclerosis, goiti and nephric calculosis disease /T. Vague // Am. J. Clin. Mutr. – 1956. – № 4. – P. 20–34.

24. Visceral obesity and cardiometabolic risk: features hormonal and immune regulation / I.V. Kologrivova [et al.] // Obesity and metabolism. - 2017. - T. 14, No. 3. - S. 3-10.
25. Yusuf, S. Effect of potentially modifiable risk factors associated with myocardial infarction in 52 countries (The INTERHEART study); case-control study / S. Yusuf, S. Hawken, S. Ounpuu // Lancet. – 2004. – № 364. – P. 937–52.
26. Zhuraeva Kh.I., Ochilova D.A., Kudratova D.Sh. Prevalence and detection of diabetes mellitus among the female population // Electronic scientific journal "Biology and Integrative Medicine". - 2016. - No. 2. - P. 80 - 87.
27. Zhuraeva Kh.I. Kayumov L.Kh., Ubaidova D.S., Dzhabborov Zh.Zh. The relationship of myocardial infarction with metabolic syndrome // Electronic scientific journal "Biology and Integrative Medicine". - 2019. - No. 8. - P. 66 - 77.
28. Zhuraeva Kh. I, Badridinova B.K. The relationship of arterial hypertension with the disturbance of glucose tolerance // ACADEMICIA: An International Multidisciplinary Research Journal. 2019 No. 9. - P. 17 - 22.

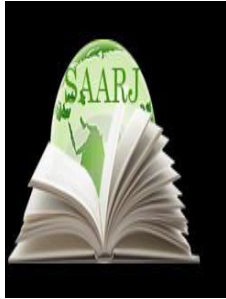

**ACADEMICIA**  
**An International**  
**Multidisciplinary**  
**Research Journal**  
 (Double Blind Refereed & Peer Reviewed Journal)

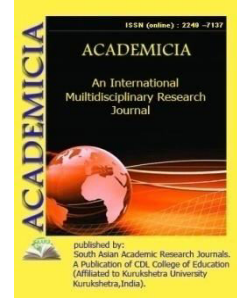

**DOI: 10.5958/2249-7137.2021.01884.X**

## NATIONAL AND EDUCATIONAL SIGNIFICANCE OF THE JADID CORPS

**Ubaydullayeva Gulruh Gayratovna\***

\*Deputy Director of Academic Affairs  
 Specialized State Secondary School Mirzo Ulugbek district,  
 UZBEKISTAN

### ABSTRACT

*In order to improve the quality of education in Uzbekistan, preserve our rich cultural heritage, as well as promote and enhance it, it is important to consolidate the resources of Jadidism on a single platform. The launch of this case is of particular importance to preserve the rich history of our country and to ensure the reliability and accuracy of ongoing research. According to world experience, such corpses have been created for a long time, and their delay in our country will lead to many unresolved socio-political problems. Given that the Corpus is a better resource than an electronic library, it is important in many ways to involve the large scientific community in its creation. One of the important tasks that must be solved when creating a corps is the use of world experience and the most accurate and practically justified methods and techniques in our country. In our opinion, the creation of this corpus is important for the consolidation of studies of Jadidism and for determining the accuracy of the approaches and scientific conclusions that they put forward in the past. A corpus that brings together the sources of Jadidism can be a valuable resource for university students, independent researchers and high school teachers in organizing their classes at a higher level, as well as for the general public.*

**KEYWORDS:** *Jadidism, Corpus, National, Educational, Electronic Library, Source, Student, Research, Research, Mantras, Spelling, Conversion, National And Educational*

### INTRODUCTION

Science research can only be valuable and useful if it is based on current demands and requirements. The process of transforming the Uzbek language into the language of information technology has increased during the country's independence years. One of the serious difficulties of Uzbek linguistics, as well as one of the urgent tasks of today, is that the Uzbek language has

not yet reached the level of Internet language, and progress in this direction is quite slow. He stated that "development of computer programs of the Uzbek language"<sup>1</sup> is one of the pressing challenges of Uzbek linguistics, noting that the establishment of a linguistic database for the formation of the national corps of the Uzbek language is an essential responsibility for Uzbek linguists.

Currently, a big door of material and spiritual chances has opened for science to advance to the next stage of growth. It fluctuates in response to the era of science and the conditions inside it, rising at times and stagnating at others, and sometimes remaining in a state of despair. The nineteenth and twentieth century's were particularly significant in the history of Uzbek science, language, culture, and literature. In the "mirror of the country of literature," Abdulla Avlani, one of the great jadids of the time, paved the way to a thorough knowledge of the sad effects of the events of the loss of freedom as a big tragedy in our people's lives and called for the struggle for independence. Westernization occurred under the influence of the era's enlightened minds, resulting in study abroad and active relationships. With the advent of the press and the theater during this period, new literary forms and genres began to emerge. The logos connected with classical poetry took on a new significance. Symbols linked with traditional poetry have been given new meanings. The forgotten old finger weight adjacent to the dream, in particular, grew more active, the first free performances began, and they were composed. In short, modern realist literature, often known as socialized literature, has evolved and even taken over the literary sphere. The spirit and content of this period's literature were shaped by the process of national awakening and the realization of the nation's identity.<sup>2</sup>

At the height of the struggle for Turkestan between the greatest colonial powers of the time, Britain and Russia, the best way to occupy the country and keep them colonized was to deprive them of the language, religion and culture of the people. The intellectuals of the time, well aware of this, united with the (new) movement of Jadidism. After the events of 1905, especially the October 17 Manifesto, it entered a stage of development. By 1916, our Jadids were embarking on a "campaign to whitewash and open the eyes of the black people" (Avloni). During the labor uprising of 1916, which left an indelible mark on the life of the country, our Jadids stood side by side with the people. Unfortunately, our people did not arrive in February 1917 with the necessary preparation, as history has created a unique condition for gaining independence. Of course, there were material and spiritual reasons for this.<sup>3</sup>

There were both material and spiritual grounds for this, of course. The difficulties were so severe that fixing them in a short period of time necessitated a large sum of money and a variety of political circumstances. Turkestan, like the rest of Russia, was enveloped in the "Bolshevik catastrophe" (Fitrat). Nonetheless, our progressive and selfless intellectuals did not give up the cause for freedom, declaring Turkestan's autonomy on November 27, 1917. In less than three months, the autonomy of Turkestan (Kokand) was brutally destroyed by the Soviets. The survivors of our so-called "nationalist". The nationalists fled to the mountains, continued to fight and were martyred for the freedom of the homeland. This process continued until the late 1920s. Therefore, 1905-1929 was a period of development and the end of the Jadid (National Awakening) movement.<sup>4</sup> The active struggle of such a glorious history and the study of the spiritual heritage of its fighters have been the focus of recent researchers. The research of Begali Kasimov, a literary scholar, has a special place in this. The scientist has been working on this topic for almost 40 years. He studied the works of Abdulla Avloni, Mirmukhsin



Shermuhamedov, Saidrasul Azizi, Sofizoda, Nozimakhanim, Sidqi Khandayliqi, Tavallo, Botu, Mirmulla, Cholpon, Fitrat, Behbudi, Kami and acquainted them with their works. However, due to the demands of the time, their struggle for independence was bypassed and their main focus was on enlightenment. It is only thanks to independence that it is possible to study the activities and heritage of these artists in detail, to evaluate them in the interests of the Motherland and the Nation. It is only thanks to independence that it is possible to study the activities and heritage of these artists in detail, to evaluate them in the interests of the Motherland and the Nation.<sup>5</sup>

The Jadid movement's sociopolitical, philosophical, scientific, and enlightenment viewpoints play an important role in training the younger generation to be well-rounded individuals. The interest in the activities of the Jadids did not leave indifferent not only domestic but also foreign scholars. In particular, it has been described in one way or another in the studies of Jadid studies by orientalists such as the Americans Adib Khalid,<sup>6</sup> E. Alworth, A. Benningson of France, I. Baldauf<sup>7</sup> of Germany, Professor E. Lazzeri of Orleans, H. Komatsu of Japan. Researchers and scholars such as A.Maniyazov, G.Ashurov, M.Shukurov, O.Sayfullayev, R.Khodizoda, A.Mirahmedov, I.Nurillin have studied the literary and historical activities of Jadids in the CIS countries. However, in research, the objective and subjective conditions of the formation of the Jadid and Jadid movement, the ideological, socio-philosophical basis of the movement, the scientific heritage of statehood and governance, their well-being, family, marriage, the Uzbek state giving views on the status of language, his views on the improvement of social existence are almost unexplored. D.Alimova,<sup>8</sup> D.Rashidova, D.Ziyayeva, R.Sharipov, R.Shamsuddinov, K.Rajabov, H.Sadikov from Uzbek historians, A.Aliyev, B.Kasimov, B.Nazarov, B.Do from literary critics Stqorayev, I.Sultan, M.Khudoykulov, N.Karimov, O.Sharafiddinov, P.Ravshanov, S.Kasimov, Sh.Rizayev, E.Karimov, G.Mahmudov, H.Boltaboyev. Socio-philosophical views of the Jadids were studied by philosophers A. Jalolov, A. Aliyev, G. Mahmudova, J. Yahshilikov,<sup>9</sup> Z. Ahrorova, N. Avazov, S. Ahmedov, U. Dolimov, Sh. Turdiev, E. Yusupov, H. Saidov. and others. The purpose of this research is to reveal the socio-philosophical nature of the national and universal essence of the spiritual heritage of the Jadids and to highlight the role of these ideas in the development of world philosophical thought. There has been a great deal of valuable research done on the sources of the Jadids, from their accurate and precise conversion to the current alphabet, to the disclosure of its content.

It is now an urgent task to systematically and sequentially assemble the sources of the period of acceleration on one platform, to create a lot of convenience in their use, to draw more accurate scientific conclusions by assembling them in one place, and to create their corps in order to deliver without loss to future generations by assembling them in one place. Now, vital research on the Corps is underway, with the goal of meeting the period need. In this regard, the work of researchers such as M. Abjalova, a doctor of philological sciences, professor under the direction of B. R. Mengliyev Sh.Hamroyeva, A.Eshmo'minov,<sup>10</sup> O'. Khalyarov, is of particular interest.

A body is a collection of texts that are subjected to a search engine to determine the features of language units, whether written or spoken, saved in electronic form in a natural language, and placed online or offline using computerized search engine software.<sup>11</sup> The e-library is only capable of gathering and displaying books. In addition to compiling texts, the language corpus analyzes and modifies them based on linguistic phenomena and finds statistical data, such as words, adjectives, and other levels of language in a play. As well as the ability to give statistical data on them.

Many of the world's languages have their own national corps, which varies in terms of quality and capacity to handle texts scientifically. English-language Brown Corps, Lancaster-Oslo/Bergen (LOB) Corps, London-Lund Corps, American Heritage Corps for Lexicographic Studies, Lancaster English Speaking Corps, Helsinki Corps of English Texts Listed in Diachronic Corps, English for Linguistic Didactic Research, and English for Linguistic Didactic Research The National Corps' importance and involvement in the formation of national and state languages demonstrates the significance of this.

Aside from the national corps, of English, Spanish, Chinese, Arabic, French, Russian, German, Polish, Polish-Ukrainian, Czech, Slovak, Serbian, Croatian, Bosnian, Bulgarian, Bulgarian-Russian, Macedonian, Scottish, Dutch, Dutch -French, Swedish, Dutch, Norwegian, Icelandic, Faroese, Medieval French, Italian, Portuguese, Romanian, Lithuanian, Latvian, Greek, Eastern Armenian, Ossetian, Albanian, Indian, Gypsy, Hittite, Finnish, Uralic, Estonian, There are corpses of Veps, Hungarian, Udmurt, Georgian, Anglo-Georgian, Lezgin, Turkish, Tatar, Bashkir, Crimean Tatar, Kalmyk, Buryat, Mongol, Hebrew, Amharic, Japanese, ancient Japanese, Baman, Esperanto. In world computer linguistics, the existence of the National Language Corps is seen as a criterion for the viability of a language and its transformation into a computer language.<sup>12</sup>

Because the corpus is such a big information space, the more you increase it, the more precise and valuable conclusions you can draw. In this scenario, forming a separate corps of Jadidism sources is a critical endeavor. To that purpose, a number of the initiatives listed below will be carried out in close collaboration with professionals conducting research in this field:

- Sources of Jadid literature and dramaturgy will be discovered, studies and analyses will be conducted, and sources published in the Uzbek press on the basis of the Jadid movement will be updated;
- an electronic database of Jadid sources will be created;
- artistic, literary-scientific, scientific-enlightenment, linguistic problems of the Jadid period will be clarified on a scientific basis;
- an annotated bibliography of sources on the national language and spelling;
- When creating an electronic database, electronic copies of the original literature of the Jadid period are also placed;
- The placement of research work with a foundation related to seriousness will also be ensured.

As a national and educational corps, this corps, which includes Jadid period materials, provides practical benefits in the educational process of philology and journalism in higher education, as well as the construction of textbooks and manuals. It also serves as a convenient resource for both domestic and international professionals.

#### **LIST OF REFERENCES:**

- Decree of the President of the Republic of Uzbekistan No. PF-5850 "On measures to radically increase the prestige and status of the Uzbek language as the state language."
- Khalid Adeeb. The Politics of Muslim Cultural Reform: Jadidism in Central Asia. – Berkeley: University of California Press, 1998

- Baldauf Ingeborg. Jadidism in Central Asia within Reformism and Modernism in the Muslim World // Die Welt des Islams, New Ser. Vol.41, Issue 1. (Mar., 2001).
- Алимова Д.А. Историческое мировоззрение джадидов и их проекция будущего Туркестана // From the pages of the struggle for independence and unity of Turkestan. Tashkent: Fan, 1996.
- Yaxshilikov J. Jadidism and Behbudi. –Tashkent: “Fan”, 2004.
- Eshmo'minov A. Synonymous database of the Uzbek National Corps. F.f.f.d. (PhD) abstract. Termiz. 2019.y.
- Annotated dictionary of Uzbek language. Volume V. Volume 1 - Tashkent: National Encyclopedia of Uzbekistan, 2020. 56 p
- Safarov.Sh. Cognitive linguistics. Samarkand. 2006 Abdullaeva M. et al. Brief Dictionary of Philosophy. Tashkent. 2004 Nazarov Q. Philosophy .Tashkent. 2000
- Sayfullaeva R., Mengliev B. and others. Modern Uzbek literary language is Tashkent. 2010. Bozorov O. Leveling in Uzbek language. F.f. diss for doc.. Tashkent 1997
- Sayfullaeva R. Synonymy of narrative sentences in the modern Uzbek language. can.phil. sciences. abstract,T,:1982 Hojiev.A. Annotated Dictionary of Linguistic Terms. Toshkent.O'zME. 2002 y.

**INTERNET RESOURCES:**

1. www. <http://lex.uz/docs/4561730>

2. <http://marifat.uz/marifat/ruknlar/fan/1241.htm>

[http://library.navoiy-uni.uz/files/b.qosimov.%20milliy\\_uygonish\\_adabiyoti\\_ziyouz\\_com.pdf](http://library.navoiy-uni.uz/files/b.qosimov.%20milliy_uygonish_adabiyoti_ziyouz_com.pdf)



**ACADEMICIA**  
**An International  
 Multidisciplinary  
 Research Journal**  
 (Double Blind Refereed & Peer Reviewed Journal)

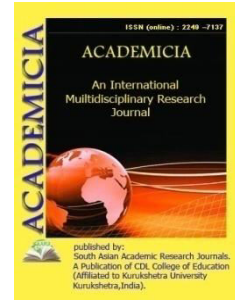

**DOI: 10.5958/2249-7137.2021.01885.1**

**PRESCHOOL EDUCATION REFORM**

**Shamuratova Khurliman Kutlimuratovna\***

\*Lecturer,  
 Department of Distance Learning,  
 Nukus State Pedagogical Institute,  
 UZBEKISTAN

**ABSTRACT**

*Preschool education. This area, which is the primary link in the system of continuing education, plays an important role in the development of a comprehensively healthy and well-rounded child and his preparation for school. However, analyzes have shown that in recent years, under the influence of various factors, instead of progress in preparing children for school education in the pre-school education system, there has been a decline in the coverage of preschool children throughout the year. no growth trend was observed. The specialists who grew up in them made up a very small part of the country's population. In some cases, people were illiterate and even did not have a general 11-year education. In particular, a system of compulsory 12-year free education has been created, which is available only in a few countries around the world. Many higher education institutions are equipped with the most advanced educational technologies for in-depth education of young people like us.*

**KEYWORDS:** *Preschool Education, Child Rearing, Educator, Continuing Education, Education Reform.*

**INTRODUCTION**

Preschool education is the primary link in the system of continuing education, which plays an important role in the development of a comprehensively healthy and harmoniously developed child's personality and preparation for school. At present, Uzbekistan is making great strides in the field of education. If we look at the recent past, during the Soviet era, there were only a few educational institutions in Uzbekistan, most of which were not in demand. The specialists who grew up in them made up a very small part of the country's population. In some cases, people were illiterate and even did not have a general 11-year education. It was a well-thought-out ploy by the Soviet government to capture the nation's consciousness with a communist ideology that

was alien to the Uzbek people. At the same time, their ultimate goal was to keep the people dependent and under strong pressure. But their plan did not materialize, and our people, who grew up in the spirit of freedom, fought for independence and achieved the long-awaited day.

From the first days of independence, a great deal of attention has been paid to every field, and a radical change has taken place in the field of education. From year to year, more and more attention is paid to young people. In particular, a system of compulsory 12-year free education has been created, which is available only in a few countries around the world. Many higher education institutions are equipped with the most advanced educational technologies for in-depth education of young people like us. As a result, Uzbek youth are on the podium at international science competitions. In every speech, the head of our state has repeatedly said: "Our children must be stronger, more educated, wiser and, of course, happier than us."

During the years of independence, the education system of the republic and the upbringing of a harmoniously developed generation have risen to the level of the main priorities of state policy. However, the analysis shows that the effectiveness and results of the work done in the field of preschool education are insufficient.

The majority of teachers working in public preschools have secondary special education, which does not allow them to prepare children for school education at the required level.

In addition, the assessment of the quality and effectiveness of the educational process in preschool institutions does not meet modern requirements, as monitoring of the quality of preschool education is not structurally and organizationally planned.

The analysis of best practices of foreign countries is characterized by the focus on creating conditions for the development of preschool children in modern preschool institutions, the demonstration of opportunities for positive socialization of the child, his all-round spiritual and moral development, to develop initiative and creative skills based on relevant types of activities, to open opportunities for cooperation with adults and peers in the context of communication.

It is natural that the spiritual criteria and views that determine the character, nature and worldview of the child - the basis of such concepts as goodness, kindness, nobility and compassion, honor and dignity - are determined in the family. Therefore, if we take into account the duty of the family to the motherland, the duty to the parents, the teaching of human qualities, it is during this period that the first buds of spirituality in the heart and mind of the child under the influence of the family and preschool environment begins to appear.

Preschool education, which is the first stage of the foundation of education, ensures the formation of a healthy, well-rounded child, awakens in the child a desire to learn, to teach him regularly. the preparatory process is carried out.

The Ministry of Preschool Education was established by the decree of Shavkat Mirziyoyev dated September 30, 2013 "On measures to radically improve the management of the preschool education system." The main tasks of the new ministry are to gradually cover all children in the pre-school education system, create a network of competing state and non-state pre-school educational institutions, and introduce alternative forms of pre-school education and child rearing in practice.

Extensive work is underway in the Republic of Karakalpakstan to implement this decision and decree. There are 318 preschools in the region, 3 of which are private and 7 are run by various organizations. They have 48,106 students, or 32% of the total number of children.

It is no coincidence that we pay special attention to the pre-school education system, said Shavkat Mirziyoyev. If we don't focus on educating young people today, it may be too late tomorrow. Preschools should be built based on the climatic conditions of Karakalpakstan. Each room should have a heated floor. It is also necessary to reconsider the system of training in this area, for which it is necessary to organize special courses at higher education institutions. The level of educators is important for the future of children. It is not justified to build such facilities on the basis of old-fashioned projects. We need to make children's dormitories and classrooms spacious and bright, and reduce the number of administrative rooms, the head of state said.

There was a presentation of standard projects of 50, 100, 150-seat preschools. The new projects include the further expansion of the public and private sectors of preschool education, the creation of a healthy competitive environment between them, the introduction of new forms of preschool education in public-private partnerships.

The President stressed the need to use the experience of South Korea in the preparation of projects for new kindergartens.

The economic power of each country, the increase in the level of socio-spiritual life is determined by the competitiveness of the education system, the development of science.

Therefore, the Action Strategy for the further development of the Republic of Uzbekistan prioritizes radical improvement of education, improving the quality of education, the formation of a generation of intellectually gifted, physically fit, in-depth teaching of specific sciences and training of qualified personnel for various sectors of the economy and ultimately to create a system of education that can meet the demands of today. The implementation of such ambitious tasks in the future will require the improvement of the regulatory framework of the industry. Therefore, a very important task is to develop a draft law "On Preschool Education" based on best international practices.

It is no coincidence that we pay special attention to the pre-school education system, said Shavkat Mirziyoyev. If we don't focus on educating young people today, it may be too late tomorrow. Preschools should be built based on the climatic conditions of Karakalpakstan. Each room should have a heated floor. It is also necessary to reconsider the system of training in this area, for which it is necessary to organize special courses at higher education institutions. The level of educators is important for the future of children. It is not justified to build such facilities on the basis of old-fashioned projects. We need to make children's dormitories and classrooms spacious and bright, and reduce the number of administrative rooms, the head of state said.

There was a presentation of standard projects of 50, 100, 150-seat preschools. The new projects include the further expansion of the public and private sectors of preschool education, the creation of a healthy competitive environment between them, the introduction of new forms of preschool education in public-private partnerships.

The President stressed the need to apply the experience of South Korea in the preparation of projects for new kindergartens.



The economic power of each country, the increase in the level of socio-spiritual life is determined by the competitiveness of the education system, the development of science.

Therefore, the Action Strategy for the further development of the Republic of Uzbekistan prioritizes radical improvement of education, improving the quality of education, the formation of a generation of intellectually gifted, physically fit, in-depth teaching of specific sciences and training of qualified personnel for various sectors of the economy and ultimately to create a system of education that can meet the demands of today. The implementation of such ambitious tasks in the future will require the improvement of the regulatory framework of the industry. Therefore, a very important task is to develop a draft law "On Preschool Education" based on best international practices.

It should be noted that the development of this bill, in turn, will serve to further improve our national legislation in the field of education, strengthen the legal framework of all relations in this area.

Therefore, ensuring the implementation of the tasks set by the system requires the deputies of the Legislative Chamber to be more active and responsible.

#### **REFERENCES:**

1. Karimov I. Uzbekistan national independence, economy, political ideology. T. 1996y, p.82
2. Uzbekistan is on the verge of independence. Speech by Islam Karimov, 1991.
3. Education statistics in Uzbekistan. 2019 y
4. [www.lex.uz](http://www.lex.uz)

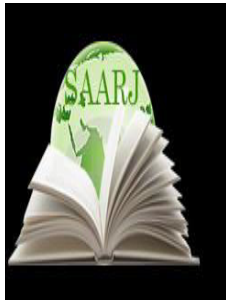

**ACADEMICIA**  
**An International  
Multidisciplinary  
Research Journal**  
**(Double Blind Refereed & Peer Reviewed Journal)**

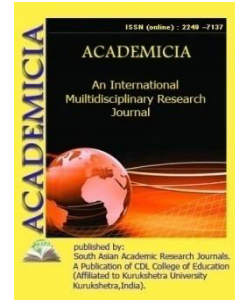

**DOI: 10.5958/2249-7137.2021.01914.5**

## **METHODS FOR REDUCING SEISMIC FORCES ACTING ON BUILDINGS AND STRUCTURES**

**Egamberdiyev B.O\***

\*PhD Student,  
Ferghana polytechnic institute,  
UZBEKISTAN

### **ABSTRACT**

*This article examines, analyzes, and develops recommendations for reducing seismic forces affecting buildings and structures. Various devices have been developed and put into practice by scientists. The advantage of these devices is that their use in dynamic structures allows to reduce the seismic forces acting on buildings and structures. In viscous and dry friction dampers, the friction work decreases sharply with decreasing vibration amplitude, while it is advisable to keep the damper energy distribution level unchanged to maintain efficiency, which also requires the system to maintain the vibration amplitude unchanged. The introduction of damping allows to significantly expand the effective frequency range of vibration dampers. Despite measures to prevent vibration (vibration), including the use of vibration isolations, vibration of a particular structure in the excitation harmonic series is still common.*

**KEYWORDS:** *Active, Passive, Base, Damper, Friction Damper.*

### **INTRODUCTION**

The main purpose of earthquake protection measures used in construction today is to reduce the seismic forces acting on the building and structure. The use of such devices in the construction of buildings and structures allows to improve the dynamic characteristics and significantly reduce the impact of seismic forces.

In recent years, the method of seismic insulation of buildings and structures from the effects of earthquakes is developing around the world. Various devices have been developed and put into practice by scientists. The advantage of these devices is that their use in dynamic structures allows to reduce the seismic forces acting on buildings and structures. They are usually divided into active and passive measures to protect buildings and structures from earthquakes.

Seismic resistance is achieved through the use of vibration damping material in the construction of buildings and structures at the beginning of construction. In ancient times, in some cases, builders insulated the foundation by installing soft pads in the form of a special compound or reed gasket on top of the foundation to reduce the impact of earthquakes on buildings and structures. All of these methods can be called methods of seismic protection of buildings and structures located in the structure. Some authors call them passive methods of protecting buildings and structures from the effects of earthquakes [1-2].

At the beginning of the last century, there was a tendency to add additional connections to the construction of buildings and structures. They are very diverse and can be called a constructive method of extinguishing seismic vibrations of buildings and structures. In practice, such devices are often found in the form of seismic insulation systems with flexible low-rise buildings, vibrating column buildings on kinematic supports, springs, balls, houses on rubber-metal supports, etc. [3-4]. Some authors call them an active way to protect buildings and structures from the effects of earthquakes.

To date, there are various devices that absorb the energy of seismic forces applied in the practice of construction of buildings and structures. These devices are used in various parts of buildings and structures (foundation, floor level, roof, etc.).

The design of the method of active protection of buildings and structures is diverse. The use of each type of device in different parts of buildings and structures allows to improve their dynamic characteristics by changing their geometric parameters. As a result, significant results can be achieved in ensuring their seismic stability.

Statistics show that in recent years, the number of such devices used in the construction of buildings and structures around the world to ensure their seismic resistance has increased (Fig 1). The main part of extinguishing devices used in buildings and structures are rubber and sliding supports with additional extinguishing devices.

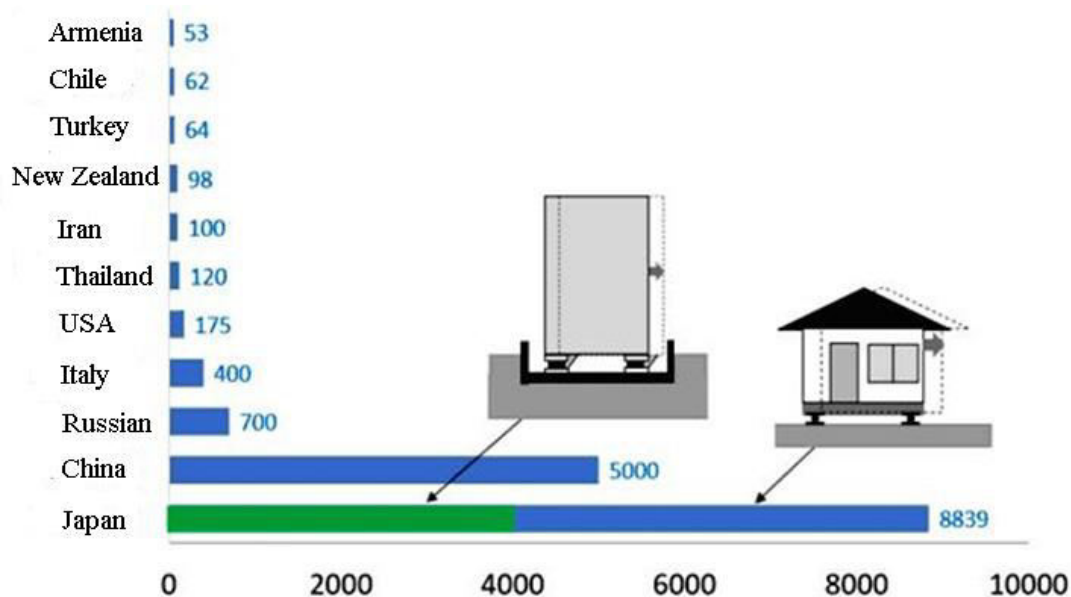

Figure 1. Quantitative indicators of the use of seismic insulation in countries around the world.

Active (active) protection of buildings and structures from earthquakes can include dry friction joints, hysteresis-type friction, connecting and disconnecting joints, etc. [5-6]. Various extinguishers and dampers play an important role in active anti-seismic measures. They allow to improve the dynamic characteristics of buildings and structures. Their designs can be selected during the design process. Dynamic vibration dampers are made in the form of an additional mass attached to the protected structure by means of elastic and damping element. Extinguishers that move along a curved surface or are suspended, such as a pendulum, are also widely used. The extinguisher design consists of a solid body with separate loads or a removable load or container filled with liquid. Elastic elements include steel springs, rubber elements, elastic rods or plates, and materials with high dissipative properties for energy dissipation. The dynamic vibration damper is named after Fram, first invented in 1909. This extinguisher was invented to calm the vibrations of ships from the waves [7-8]. The introduction of damping allows to significantly expand the effective frequency range of vibration dampers. Despite measures to prevent vibration (vibration), including the use of vibration isolations, vibration of a particular structure in the excitation harmonic series is still common. For some reason, it seems impossible to change the mass of the structure or the elastic variable in order to get out of the resonance zone. In such cases, they try to use dynamic dampers. Currently, there are rubber-based, sliding-based, steel-based, arc-based lead-based, hydraulic shock absorbers and friction dampers, etc. in the construction industry around the world. Extinguishing devices in the form of

Rubber-metal supports. Vertical cylindrical lead-core rubber-metal supports that act as energy absorbers have been proposed in [9-10]. It is believed that the lead core provides high hardness in the vertical direction. Under strong seismic effects, large plastic deformations occur in the core, which allows to increase the vibration damping by 3-5 times. Such a structure is the most economical system of seismic insulation, but studies have shown that in some cases the lead core can be damaged (Fig 2.a).

Steel supports. Japanese scientists have invented steel supports to increase the seismic strength of buildings and structures. Such supports allow to work in transverse, longitudinal, vertical and rotational (torsional) vibrations during an earthquake. Since the Kobesko earthquake in Japan in 1995, more than 150 houses have been built each year using this type of foundation [11-12]. This base is located between the foundation and the trunk of the building. During an earthquake, the base allows the foundation under the beam to mix, and as a result, most of the energy from the foundation does not pass to the surface of the building. Applying this insulation almost halves the seismic force. The base is made of high-strength elastic steel in the form of four round springs (Fig 2.b). The disadvantage of this seismic insulating base is that it corrodes in wet conditions, and over the years, the steel loses its strength due to stress.

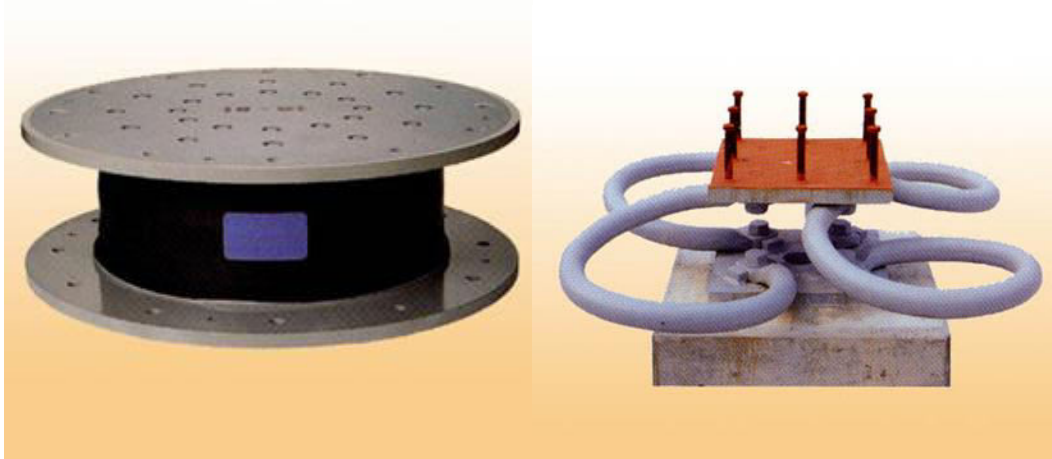

Figure 2.a - rubber base, b - steel base.

Bow-shaped lead supports. Japanese scientists have invented a seismically insulating base in the form of an arc in the form of lead [13-14]. The base is firmly attached to the foundation of the building with the foundation.

This base is made of rubber and steel. Lead has plastic properties, so most of the energy generated in the foundation during an earthquake is lost due to the plastic properties of the base. The effect of this type of insulating base is significant, the seismic force is almost halved (Fig 3 a).



Figure 3.a - arc lead base, b - adhesive shock absorber for buildings.

Adhesive friction shock absorbers. Adhesive friction shock absorbers with elastic couplings are widely used in construction practice [15-16]. The elastic bond in them is usually in the form of a spring containing a liquid that sticks to the cylinder. Deformation of the shock absorber causes energy loss due to the sticky friction in the cylindrical bath. In viscous and dry friction dampers, the friction work decreases sharply with decreasing vibration amplitude, while it is advisable to keep the damper energy distribution level unchanged to maintain efficiency, which also requires the system to maintain the vibration amplitude unchanged. This resistance is easily lost in adhesive friction dampers, because in such dampers it is known that due to the significant oscillation of the damper mass it is possible to achieve complete calm of the main system and



obtain a significant energy dissipation by adding adhesive resistance to the damper system. The main disadvantages of elastically connected dampers, as is well known, are that they have a more pronounced selected properties, absorbing the vibrations of the desired part. The disadvantage of many viscous friction dampers is that the viscosity properties of the oils are not constant with temperature changes, which leads to deformation of the dampers (Fig 3 b).

Friction damper. Scientists have developed a dry friction damper for use in frame buildings [17-18]. Such a damper is used in the frame cell of the X-shaped and L-shaped connection. Such joints usually provide the transverse and longitudinal rigidity of frame buildings. During an earthquake, dry friction occurs due to the displacement differences of the layers in the friction damper due to the displacement of the two channels (Fig. 4 a). There is a special gap between the supports and the main channel to allow the sliding channels to move. Due to the elastic fastening of the two channels with the help of bolted joints, the Coulomb force was created on the surface of the channel during the movement.

These dampers come in many forms in the construction industry. These dampers are mainly used in high-rise buildings. The effect of such a damper is a sharp decrease in the amplitude of vibration due to dry friction during an earthquake and the vibration does not fall into the resonant mode.

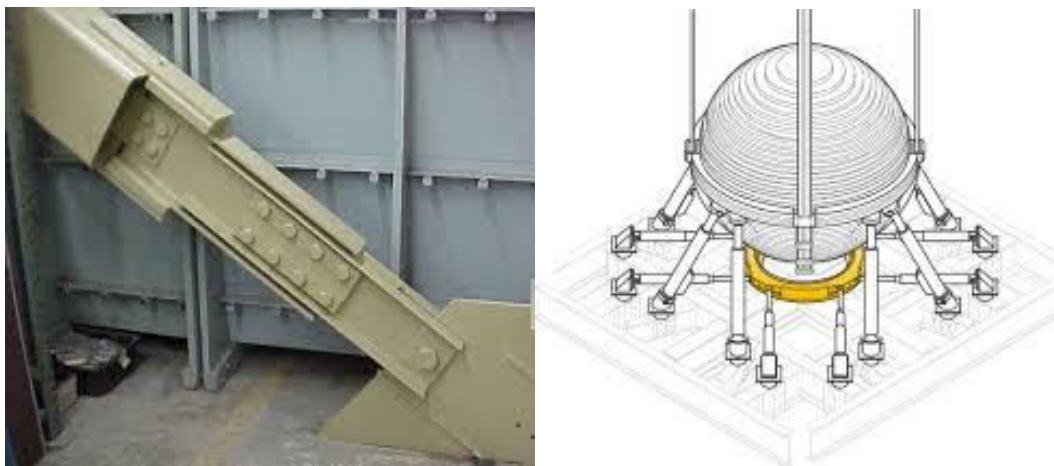

Figure 4.a - friction damper, b - pendulum damper in high-rise buildings.

Pendulum Extinguisher. Pendulum dampers for use in tall buildings and structures have been proposed in the study [19-20]. For damping, the dampers are installed at a height (mark) selected according to the trajectory of the center of gravity of the load. Damping in pendulum extinguishers is carried out by means of steel wings. Experimental studies have shown that the decremental oscillations of such a extinguisher initially increase with increasing oscillation amplitude and then decrease. At relatively large amplitudes of vibrations, the damping on the wing (rope) is determined by the dry frictional forces between the threads. A second accessory connected to the extinguishing mass near the lower end of the cable may be used to increase damping. The advantage of such extinguishers is their simplicity of design, durability and ease of use (Fig 4 b).

## CONCLUSION

Based on the above data, the following conclusions and recommendations were made:



- Design and construction of buildings and structures using active seismic systems in construction practice;
- Installation of dynamic shock absorbers in the construction of multi-storey buildings, especially to help reduce the level of high-spectrum, high-frequency vibrations, loads on the upper floors of buildings during shock and seismic propagation;
- Installation of earthquake dampers with a certain mass on the roofs of multi-storey buildings;
- In the construction of 1-2-storey buildings and structures, to reduce the impact of earthquakes by creating a special layer under the foundation;

## REFERENCES

1. Abdurashidov K.S., Shadmanova Z.S. Analysis of the state of structures of architectural monuments of Uzbekistan // Journal. Mechanical problems. –Tashkent, 1998. –№3. – C.42–45.
2. Aisenberg Ya.M. Seismic isolation and adaptive seismic protection systems. - M.: Nauka, 1983.- P.37-40.139.
3. Korenev B.G., Reznikov L.M. Dynamic vibration dampers (theory and technical proposals). –M.: Nauka, 1988.-p. 108.
4. Alekseev A.M., Sbrovsky A.K. Marine vibration dampers. -Leningrad, Sudpromgiz, 1962.- p.196.
5. Designer handbook. Dynamic calculation of buildings and structures. -M.: Edited by professors B.G. Korenev, I.M. Rabinovich. Stroyizdat, 1984.- p. 310.
6. Y.Jiao, S.Kishiki, D.Ene, S.Yamada, N.Kawamura, Y.Konishi. Plastic deformation capacity and hysteretic behavior of U-shaped steel dampers for seismic isolated-buildings under dynamic cyclic loading. Tenth U.S. National Conference on Earthquake Engineering Frontiers of Earthquake Engineering. July 21-25, 2014. Anchorage, Alaska. 150-154 pp.
7. Baoshun Wang, Weiming Yan, Haoxiang He. Mechanical Performance and Design Method of Improved Lead Shear Damper with Long Stroke. International scientific journal of “Shock and Vibration”, Volume 2018, Hindawi Publishing, London, United Kingdom. 31-37 pp.
8. Akira Fukukita, Tomoo Saito, Keiji Shiba. Control Effect for 20-Story Benchmark Building Using Passive or Semiactive Device. Journal of Engineering mechanics, Volume 130, Issue 4, 2004, United States. 430-436 pp.
9. Chan R.W, F.Albermani. Experimental study of steel slit damper for passive energy dissipation. Journal of Engineering Structures. Japan Association for Earthquake Engineering, Australia, Volume 30, Issue 4, April 2008, 1058-1066 pp.
10. Nadathur Varadarajan, Satish Nagarajaiah. Wind Response Control of Building with Variable Stiffness Tuned Mass Damper Using Empirical Mode Decomposition/Hilbert Transform. Journal of Engineering Mechanics. Volume130, Issue4, 2004, United States. 451-458 pp.

11. Khojmetov G. K., Yuvmitov A. S. Coupling Unit of the System “Building-Adjacent Structure” //Patent of the Republic of Uzbekistan on Effective Model, No. FAP. – 2014. – T. 973. – №. 03.11. – C. 2014.
12. Yuvmitov A., Hakimov S. R. INFLUENCE OF SEISMIC ISOLATION ON THE STRESS-STRAIN STATE OF BUILDINGS //Acta of Turin Polytechnic University in Tashkent. – 2021. – T. 11. – №. 1. – C. 71-79.
13. Abobakirova Z. A. Regulation Of The Resistance Of Cement Concrete With Polymer Additive And Activated Liquid Medium //The American Journal of Applied sciences. – 2021. – T. 3. – №. 04. – C. 172-177.
14. Davlyatov S. M., Makhsudov B. A. Technologies for producing high-strength gypsum from gypsum-containing wastes of sulfur production-flotation tailings //ACADEMICIA: An International Multidisciplinary Research Journal. – 2020. – T. 10. – №. 10. – C. 724-728.
15. Sagdiev K. S. et al. Assessment Of Seismic Resistance Of Existing Preschool Educational Institutions And Recommendations For Their Provision Seismic Safety //The American Journal of Applied sciences. – 2020. – T. 2. – №. 12. – C. 90-99.
16. Mirzaakbarovna M. S. Wood Drying In Construction //The American Journal of Applied sciences. – 2021. – T. 3. – №. 5. – C. 229-233.
17. Mahkamov Y. M., Mirzababaeva S. M. Strength of bending reinforced concrete elements under action of transverse forces under influence of high temperatures //ACADEMICIA: An International Multidisciplinary Research Journal. – 2020. – T. 10. – №. 5. – C. 618-624.
18. Egamberdiyev, B. O. "A Practical Method For Calculating Cylindrical Shells." The American Journal of Engineering and Technology 2.09 (2020): 149-158.
19. Asrorovna A. Z. Effects Of A Dry Hot Climate And Salt Aggression On The Permeability Of Concrete //The American Journal of Engineering and Technology. – 2021. – T. 3. – №. 06. – C. 6-10.
20. Makhkamov, J.M., & Mirzababayeva, S.M. (2019). Bending Of Bended Reinforced Concrete Elements Under The Action Of Transversal Forces And Technological Temperatures. Problems of modern science and education, (12-2 (145))

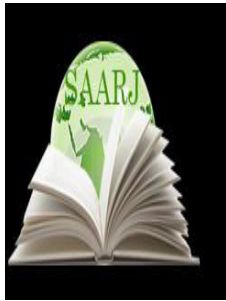

**ACADEMICIA**  
**An International**  
**Multidisciplinary**  
**Research Journal**  
 (Double Blind Refereed & Peer Reviewed Journal)

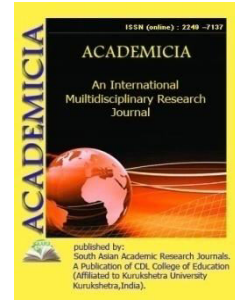

**DOI: 10.5958/2249-7137.2021.01887.5**

## EXPLORING THE TECHNOLOGICAL POSSIBILITIES OF NEXT-GENERATION FLAT KNITTING MACHINES

**Elyor Kholboyev\***; **Dilafuz Khamidova\*\***; **Maftunakhon Abdurakhimova\*\***;  
**Nilufar Khankhadjaeva\*\***

\*Djizakh Polytechnical Institute,  
 Islam Karimov Djizakh, UZBEKISTAN

\*\*Tashkent Institute of Textile and Light Industry,  
 Shokhjahan Tashkent, UZBEKISTAN

### ABSTRACT

*In this article technological possibilities of double bed flat knitting machines have been investigated to create cardigan knitting structures. Cardigan knitting structures have been created on the base of rib structures and tuck loop elements have been added into structure. Variants of cardigan knitting with cardigan effect were developed and produced to observe different changes in technological parameters. In this work structures and notations of two variants are offered as complex cardigan knitting structure.*

**KEYWORDS:** *Flat Knitting Machine, Needle, Loop, Tuck Loop, Structure, Technological Parameters, Notation, Properties.*

### INTRODUCTION

Double needle bed flat knitting machines are weft knitting machines, and the technological potential of such machines is very wide. Many structure types are available. In addition to the main and derivative fabrics, there are several different pattern knitting fabric variants are possible to produce. Several knitting factories in Uzbekistan are equipped with such machines, which are used to produce fabrics for different types of assortment. However, the technological potential of the new generation of flat knitting machines has not been fully used. This series of machines has a very wide range of technological capabilities due to the fact that they are equipped with computer programs. In order to further study the technological possibilities of the machine, to create new types of knitted fabrics, scientific works, patent materials, articles in scientific journals related to the machines of this category and the types of fabrics obtained from them were studied and analyzed in depth [1-4].

Flat knitting machines are equipped with pattern making control mechanisms. In many types of machines, the pattern making program is often defined by attaching the loop knitting systems with different threads, feeding the needles in different positions of the them, and setting the lifting cams in three or four positions (clearing, pressed, semi-pressed, and miss). On some machines, changing the position of the clearing cams is done in the operating mode using special mechanisms. The machines are equipped with long and short batt needles.

The machine also has tuck position cams, which are used to form the cardigan stitches. Such cams raise the needles to the semi-clearing position, resulting in the formation of cardigan stitches along with the loop. The presence of such additional cams allows the knitting machine to produce pattern knitted fabrics in addition to simple smooth fabrics.

### Methods

A tuck stitch [5] is composed of a held loop, one or more tuck loops and knitted loops (Fig.1). It is produced when a needle holding its loop (T) also receives the new loop, which becomes a tuck loop because it is not intermeshed through the old loop but is tucked in behind it on the reverse side of the stitch (Fig. 2). Its side limbs are therefore not restricted at their feet by the head of an old loop, so they can open outwards towards the two adjoining needle loops formed in the same course. The tuck loop thus assumes an inverted V or U-shaped configuration. The yarn passes from the sinker loops to the head that is intermeshed with the new loop of a course above it, so that the head of the tuck is on the reverse of the stitch. The side limbs of tuck loops thus tend to show through onto the face between adjacent wales as they pass in front of sinker loops. Tuck stitch structures show a faint diagonal line effect on their surface. In analysis, a tuck stitch is identified by the fact that its head is released as a hump shape immediately the needle loop above it is withdrawn. A knitted loop would be required to be separately withdrawn and a miss stitch would always be floating freely on the technical back.

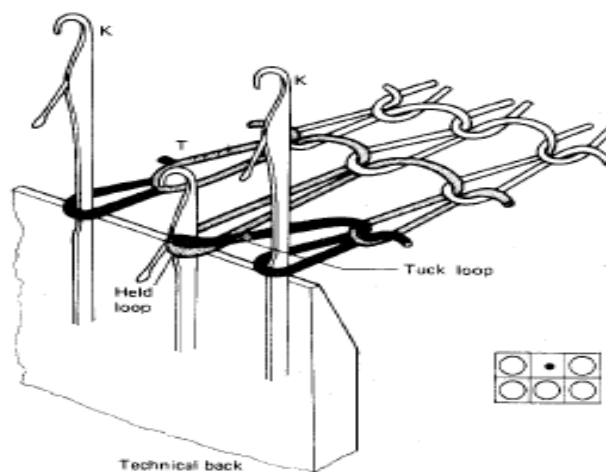
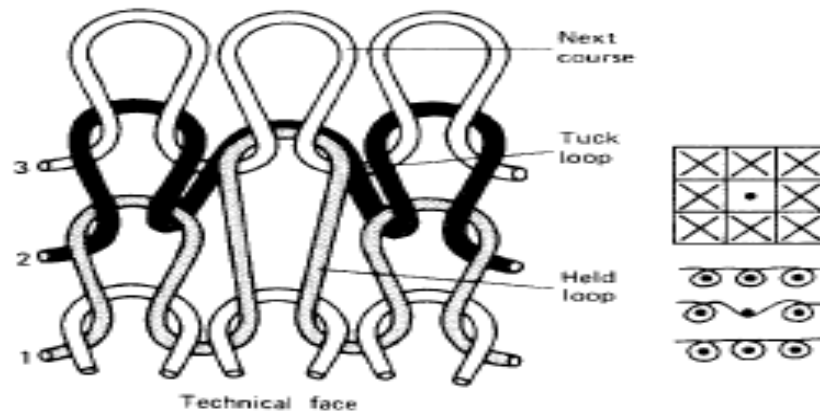

Fig. 1. Tuck stitch produced on a latch needle machine.

The tuck loop configuration can be produced by two different knitting sequences:

1 By commencing knitting on a previously empty needle. As the needle was previously empty, there will be no loop in the wale to restrict the feet of the first loop to be knitted and, in fact, even the second loop tends to be wider than normal. The effect is clearly visible in the starting course of a welt. By introducing rib needles on a selective basis, an open-work pattern may be produced on a plain knit base.

2 By holding the old loop and then accumulating one or more new loops in the needle hook. Each new loop becomes a tuck loop as it and the held loop are knocked-over together at a later knitting cycle and a new loop is intermeshed with them. This is the standard method of producing a tuck stitch in weft knitting (Fig. 1).

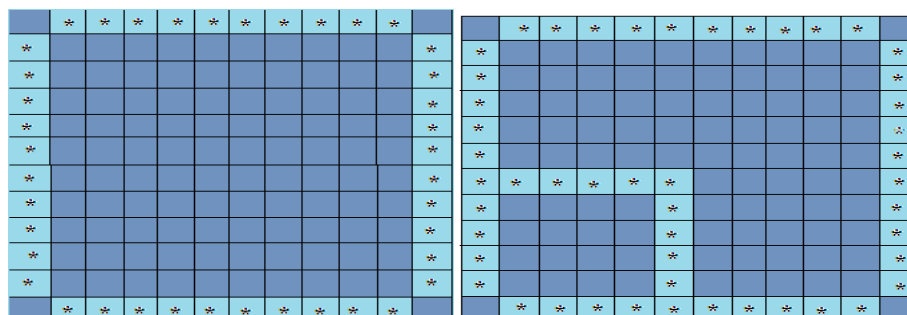

**Fig. 2.** Technical face of tuck stitch fabric.

Successive tucks on the same needle are placed on top of each other at the back of the head of the held loop and each, in turn, assumes a straighter and more horizontal appearance and theoretically requires less yarn. Under normal conditions, up to four successive tucks can be accumulated before tension causes yarn rupture or needle damage. The limit is affected by machine design, needle hook size, yarn count, elasticity and fabric take-down tension.

### Experimental work

In this research work, the technological potential of the flat knitting machine was studied and new patterned press knitted fabric structures were created. First, pattern rapport of cardigan fabric were created. They are shown in Figures 3-4 below.



**Fig. 3.** Pattern rapport for cardigan structure variants 1,2 and 5,6.

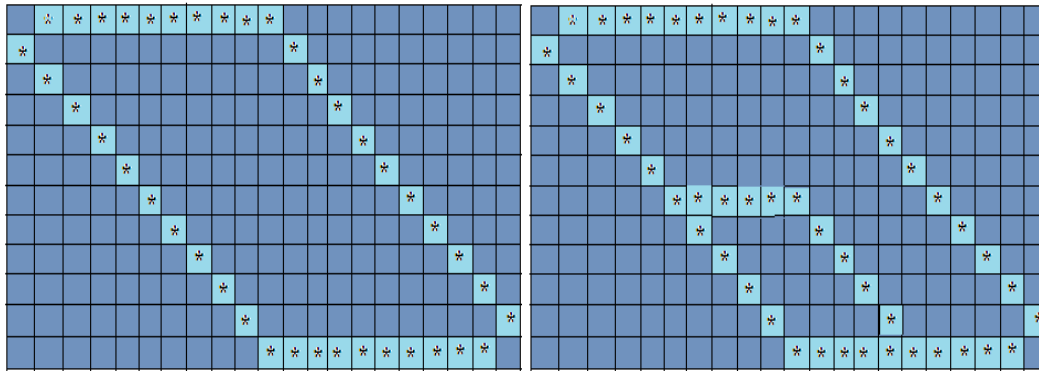

Fig. 4. Pattern rapport for cardigan structure variants 3,4 and 7,8.

In accordance with the created pattern rappers, graphic notations of the cardigan structures were created, which are designed for 1 and 2 index cardigan stitches (half loops). Below is the knitted composition and pattern ornament effect for each variant. Experiments were carried out on a double needle bed knitting machine LONG XING, installed in the knitting enterprise in the conditions of OOO "FLATNIT TEXTILE" in accordance with the rules of forming a cardigan structure for each variant.

Variant 1 of cardigan structure is shown in fig.5, the rapport of which is achieved by a pattern with a rectangular geometric ornament consisting of 24 courses and 12 wales. In the structure of the knitted fabric pattern, 1 index cardigan stitches are placed along the edges of the ornament. After each course in which the cardigan stitch is involved, a series of rib structure courses are placed to perform the process of removing the cardigan half loops. In this variant, the total rapport consists of 288 loops, accounting for 13.9% of the 40 cardigan sets placed.

Variant 2 cardigan structure's rapport is achieved by a pattern with a rectangular geometric ornament consisting of 24 courses and 12 wales. In the structure of the knitted fabric pattern, 1 index cardigan stitches are placed in a reduced shape along the edges of the ornament and in the lower left corner. After each course in which the cardigan stitch is involved, a series of rib structure courses are placed to perform the process of removing the cardigan half loops. In this variant, the total rapport consists of 288 loops, of which 17% are placed on 49 cardigan sets.

Variant 3 is a cardigan structure's rapport which has a pattern effect with a geometric ornament in the form of a parallelogram consisting of 24 courses and 21 wales. In the structure of the knitted fabric pattern, 1 index cardigan stitches are placed along the edges of the ornament. After each course in which the cardigan stitch is involved, a series of rib structure

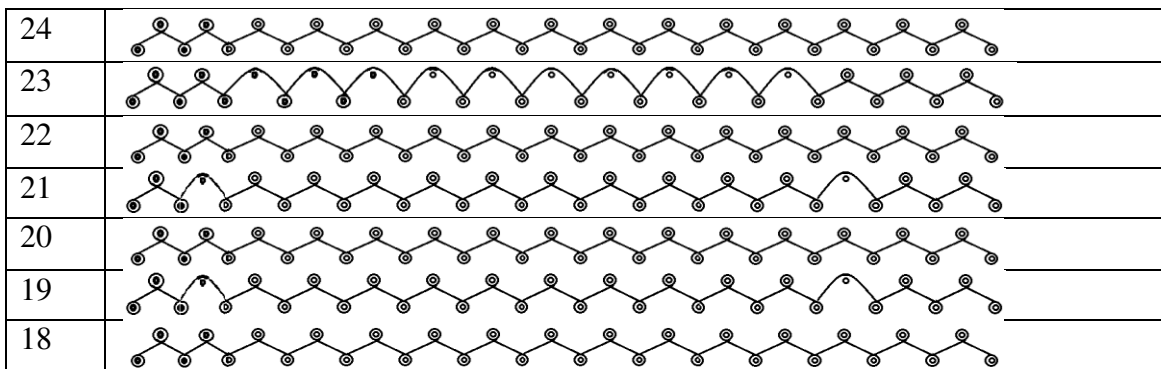









17	
16	
15	
14	
13	
12	
11	
10	
9	
8	
7	
6	
5	
4	
3	
2	
1	
	<b>1 2 3 4 5 6 7 8 9 10 11 12 13 14 15</b>
	<b>Variant 1</b>

Fig.5. Graphical notation of variant 1

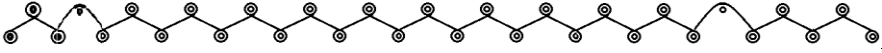
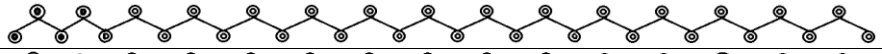
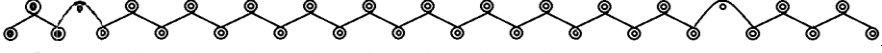
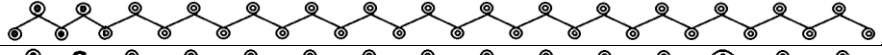
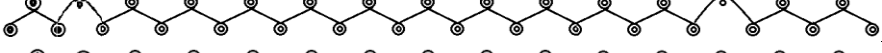
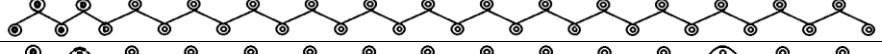
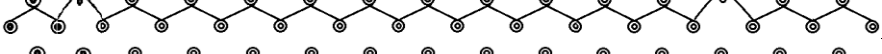
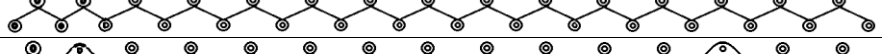
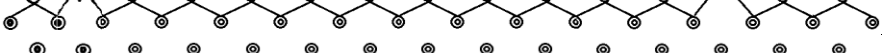
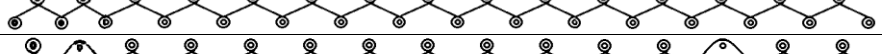
courses are placed to perform the process of removing the cardigan half loops. In this variant, the total rapport consists of 504 loops, which is 7.9% of the 40 cardigan sets placed.

Variant 4 is a cardigan structure's rapport which has a pattern effect with a geometric ornament in the form of a parallelogram consisting of 24 courses and 21 wales. In the structure of the knitted fabric pattern, 1 index cardigan stitches are placed in a reduced shape along the edges of the ornament and in the lower left corner. After each course in which the cardigan stitch is involved, a series of rib structure courses are placed to perform the process of removing the cardigan half loops. In this variant, the total rapport consists of 504 loops, of which 9.7% are placed on 49 cardigan sets.

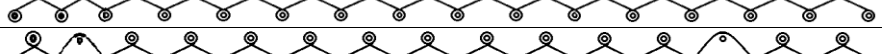
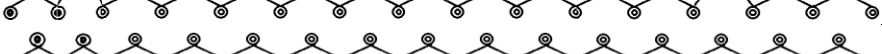
Variant 5 of cardigan structure is shown in fig.6, the rapport of which is achieved by the effect of a pattern with a rectangular geometric ornament consisting of 36 courses and 12 wales. In the structure of the knitted fabric pattern, 2 index cardigan stitches are placed along the edges of the ornament. After each course in which the cardigan stitch is involved, a series of rib structure courses are placed to perform the process of removing the cardigan half loops. In this

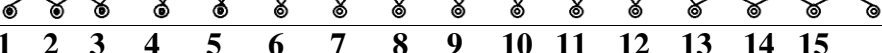
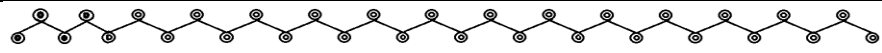
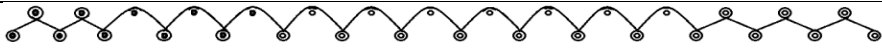
36	
35	

34	
33	
32	
31	
30	
29	
28	
27	
26	
25	
24	
23	
22	
21	
20	
19	
18	
17	
16	
15	
14	
13	
12	
11	
10	
9	
8	
7	
6	
5	
4	
3	
2	

1	
	1 2 3 4 5 6 7 8 9 10 11 12 13 14 15
	<b>Variant 5</b>

Fig.6. Graphical notation of variant 5

variant, the total rapport consists of 432 loops, accounting for 18.5% of the 80 cardigan sets placed.

Variant 6 is a cardigan knitted fabric's rapport which is achieved by the effect of a pattern with a rectangular geometric ornament consisting of 36 courses and 12 wales. In the structure of the knitted fabric pattern, 2 index cardigan stitches are placed in a reduced shape along the edges of the ornament and in the lower left corner. After each row in which the cardigan stitch is involved, a series of rib structure courses are placed to perform the process of removing the cardigan half loops. In this variant, the total rapport consists of 432 loops, accounting for 22.7% of the 98 cardigan sets placed.

Variant 7 is a cardigan structure's rapport which has a pattern effect with a geometric ornament in the form of a parallelogram consisting of 36 courses and 21 wales. In the structure of the knitted fabric pattern, 2 index cardigan stitches are placed along the edges of the ornament. After each row in which the cardigan stitch is involved, a series of rib structure courses are placed to perform the process of removing the cardigan half loops. In this variant, the total rapport consists of 756 loops, of which 10.5% are placed on 80 cardigan sets.

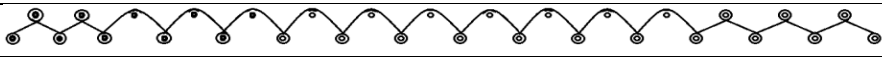
Variant 8 is a cardigan structure's rapport which has a pattern effect with a geometric ornament in the form of a parallelogram consisting of 36 courses and 21 wales. In the structure of the knitted fabric pattern, 2 index cardigan stitches are placed in a reduced shape along the edges of the ornament and in the lower left corner. After each row in which the cardigan stitch is involved, a series of rib structure courses are placed to perform the process of removing the cardigan half loops. In this option the total rapport consisted of 504 loops, of which 9.7% contained 98 cardigan sets.

## CONCLUSION

1. The types and technological capabilities of flat knitting machines, spire parts and their control were analyzed, and the experimental work was carried out on a two-needle LONG XING modern flat knitting machine.
2. Cardigan fabric structures with pattern elements added on the basis of elastic rib fabric were created and samples were taken in the conditions of FLATNIT TEXTILE enterprise.
3. Variants that differ from each other in the number of cardigan stitches and the number of half loops were developed on a flat knitting machine and prepared for the study of technological parameters and physical and mechanical properties.

## REFERENCES

1. Ramazonov ,D.Xamidova, N. Xanxadjaeva. Sposob povisheniya konkurentosposobnosti trikotajnix izdeliy.Mejdunarodniy kongress «Sivilizatsiya velikoy stepi» 19-21 may. Taras 2017g. S. 221-223.

2. Xamidova D., Ramazonov I., Xanxadjaeva N.R. Sposob povыsheniya konkurentosposobnosti tkikotajnego proizvodstva. «MOLODEJЬ i XXI vek-2017» Mejdunarodnaya nauchno-prakticheskaya konferentsiya. 21-22 fevralь. Kursk -2017g. S.391-393.
3. Hua Wang, Hafeezullah Memon. Cotton Science and processing technology (e-book). Springer Nature Singapore Pte Ltd. 2020y – 567p.
4. Xanxadjaeva N.R. Naqsh hosil qilish nazariy asoslari. Darslik. Toshkent TTYeSI bosmaxonasi. 2021y – 450b.
5. Spencer D.J. Knitting technology (Third edition). - England: Woodhead Publishing Limited, 2001. - 380 p.

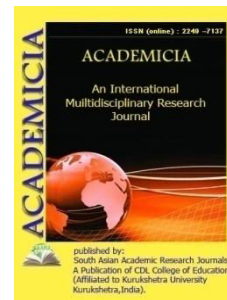
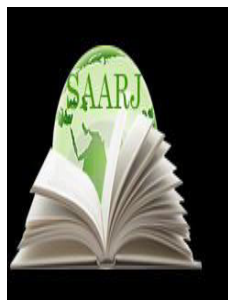

DOI: **10.5958/2249-7137.2021.01888.7**

## THE IMPORTANCE OF USING ADVANCED PEDAGOGICAL TECHNOLOGIES IN TEACHING CHEMISTRY

**Ganieva Gaukhar Bazarbaevna\***

\*Chemistry Teacher,  
Tashkent military-academic lyceum "Temurbeklar maktabi",  
National Guard of the republic of UZBEKISTAN

### ABSTRACT

*This article presents examples of didactic materials and methods of using information technology in the teaching of chemistry and the use of various teaching methods in the classroom. The education system is moving away from old-fashioned curricula to a training system that allows for training for an innovative digital economy and information society. Since competitiveness and the ability to build partnerships are necessary in such an era, the content of the curriculum should be focused on the development of critical thinking, communication, creative creativity and collaborative skills with competencies. Every teacher should know how to use advanced pedagogical technologies in lessons, the correct use of educational technologies, methods.*

**KEYWORDS:** *Pedagogical Technologies, Didactic Materials, Methods, Alkane, Alkadiene, Alkyne, Aren, Alcohols, Simple Ether.*

### INTRODUCTION

Today, our country is undergoing great reforms under the idea of "New Uzbekistan - a new worldview." Indeed, radical reforms are being carried out in our country in the social, economic and cultural spheres, as well as in the education system.

As stated in Article 41 of the Constitution of the Republic of Uzbekistan, "Everyone has the right to education ..." On the basis of this right, a number of laws have been adopted in our country. One of such legislative acts is the new adoption of the Law of the Republic of Uzbekistan "On Education" No. ZRU-637 of September 23, 2020. As stated in Article 5 of this law, "Everyone is guaranteed equal rights to education, regardless of gender, race, nationality, language, religion, social origin, and beliefs, personal and social status" and Article 15 provides for eight forms of



education. This is an indication of the comprehensive reforms in the field of education in our country.

Today, in order to take its place in the world community Uzbekistan has become one of the most developed countries in the world, so young people living in this country must have a harmoniously developed generation, high cultural level, knowledge and spirituality. In this regard, the President of the Republic of Uzbekistan Sh.M.Mirziyoyev said: "In the management of modern information technologies, as a necessary condition for the informatization of the educational process in any educational institution, uniform goals and approaches for implementation in the educational process will be developed".

Resolution of the Cabinet of Ministers of the Republic of Uzbekistan No. 230 of May 23, 2001 "On measures to organize the development of computer and information technology for 2001-2005", "Internet access to international information systems", May 30, 2002 "Further development of computerization Presidential Decree No. 3080-PF "On the introduction of information and telecommunications technologies", resolutions of the Cabinet of Ministers of the Republic of Uzbekistan dated June 6, 2002 "On the program of computerization and development of information and telecommunications technologies for 2002-2010" .

The realization of the idea behind education reform depends on a number of important factors. Student - educating our youth, who use of information technology in the classroom, advanced pedagogical technology and using non-traditional methods of assessment, using a variety of methods in the teaching of chemistry to teach the younger generation in line with modern requirements, to help them become competitive professionals in the future. The education system is moving away from old-fashioned curricula to a training system that allows for training for an innovative digital economy and information society. Accordingly, approaches to teaching are also changing, and due to the possibilities of the internet and information technology, teachers are moving from a simple educator to a core organizer. For some teachers, such a change will not be easy.

Since competitiveness and the ability to build partnerships are necessary in such an era, the content of the curriculum should be focused on the development of critical thinking, communication, creative creativity and collaborative skills with competencies. The teaching of chemistry requires the use of modern pedagogical technologies and teaching methods that allow students to learn the skills of the XXI century, they need for knowledge, basic educational, scientific and cultural competencies, critical and creative thinking, conscious choice of profession. It should be noted that the effectiveness of any advanced pedagogical technology and methods depends on the creative and professional skills of the teacher who uses it. Every teacher should know how to use advanced pedagogical technologies in lessons, the correct use of educational technologies, methods. In academic lyceums and professional colleges, the issue of independent learning of students, the development of logical thinking, their professional orientation should be the main focus of teachers.

In the process of training, the creation of problem situations on the topic using modern methods and information technology, the organization of lectures, seminars, trips, debates, conversations, conferences, problem-solving lessons, ensuring their successful solution is of particular importance.



In addition to theoretical and practical lessons in the teaching of chemistry, laboratory lessons also play an important role in obtaining the main result. In today's era of advanced technology, we also have the opportunity to conduct laboratory training virtually. For example, it is important to consider and apply the process of obtaining acetylene on "alkynes", "chemical bonds of atoms" on "chemical bonds", "interaction of particles and nuclear reactions" in the nuclear reaction mazes.

Let's take a look at some of the didactic materials on advanced pedagogical technology methods presented below in the course process. For example: by the method of "Analysis of concepts"

Analysis of concepts	
Saturated hydrocarbons	
General formula	
Homological row	
Nomenclature and isomeracy	
Properties	
To be used	

The new knowledge learned through the reading method may be able to test the readers' ability to read well. This method allows you to go to check the knowledge of a force that is removed.

The "Compatibility Fill" method

Find compatibility		
Alkane formula		$C_nH_{2n}$
Cycloalkan formula		$C_nH_{2n-2}$
Alkadien formulalasi		$C_nH_{2n+2}$
Alken formula		$C_nH_{2n-2}$
Alkin formula		$C_nH_{2n-6}$
Aren formula		$C_nH_{2n}$

In the process of teaching chemistry, it can be said that students often confuse the names of the elements that are formed as a result of chemical reactions, and in order to prevent such cases, we use the method of "finding compatibility" that encourages students to be sensitive.

Find the answer to the question on the problematic situation method		
Naming according to the systematic nomenclature	$  \begin{array}{cccccccc}  1 & 2 & 3 & 4 & 5 & 6 & 7 \\  CH_3 - CH_2 - CH - CH_2 - CH_2 - CH_2 - CH_3 \\    \\  CH_3  \end{array}  $	Naming according to the rasonal nomenclature

The method of attracting the reader's attention This "problem situation" method gives good results in any subject. We can use this method at the culmination of a lesson or in the process of finding the new knowledge we are looking for.

Assignment by assessment method

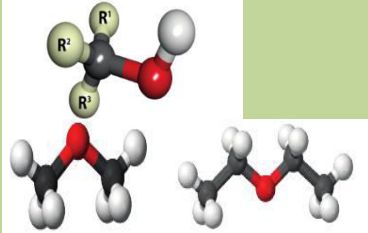
<p>Test:</p> <p>1. What is the difference between ethyl alcohol and dimethyl ether.</p> <p>A) Interclass isomerism B) Status isomerism C) geometric isomerism</p> <p>2. The difference of dimethyl ether from ethyl alcohol A) liquid B) solid C) gas</p> <p>3. Find methylpropyl ether formula?</p> <p>A) <math>\text{CH}_3 - \text{CH}_2 - \text{CH}_2 - \text{O} - \text{CH}_3</math> B) <math>\text{CH}_3 - \text{O} - \text{CH}_2 - \text{CH}_2 - \text{CH}_3</math> C) <math>\text{C}_2\text{H}_5 - \text{O} - \text{C}_2\text{H}_5</math></p>	<p>Problematic situation:</p> <p>It can be one - atomic ,two-atomic, three-atomic and multi-atomic, depending on the number of compounds-the hydroxyl group .These compounds are used a lot in various industries and in medicine. They are obtained mainly in two ways-synthesis and biochemical . They are poisonous. Which compound belongs to the above points. Answer:</p>
<p>Symptoms of methyl alcohol poisoning. Answer:</p>	<p>Practical skill</p>  <p>What is depicted in the picture?</p>

In short, “Find Compatibility”, “Concept Analysis”, “Test”, “Correct Answers”, “Assessment”, “Exprom”, “T-Scheme”, “Concept Analysis”, “SWOT”, “SCAMPER”, The use of methods such as "SCORE", "Resume", "Oral Journal" in the teaching of chemistry gives interesting results, increasing student activity, increasing knowledge and quality.

## REFERENCES

1. Law of the Republic of Uzbekistan on Education September 23, 2020
2. Mirziyoyev.Sh. "Together we will build a free and prosperous, democratic state of Uzbekistan" T .: "Uzbekistan" 2016
3. GA Ikhtiyarova, DJ Bekjanov "Modern technologies in teaching chemistry"
4. Yuldashev J.G., Usmanov S.A. Fundamentals of pedagogical technology.-T .: Teacher. 2004.-104bet.
5. Davletshin MG Psychology of the modern school teacher. T .: Uzbekistan. 1999. -29 p.

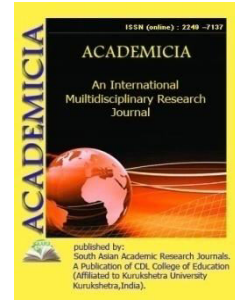
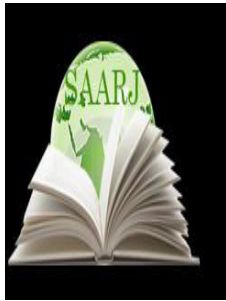

DOI: **10.5958/2249-7137.2021.01889.9**

## MANIPULATIVE RELATIONSHIP OF A DESTRUCTIVE PERSON IN THE FAMILY

**Sharafutdinova Khadichaxon Gulyamutdinovna\***

\*Associate Professor,  
Department of psychology of Termez State University,  
Candidate of Psychological Sciences,  
UZBEKISTAN

### ABSTRACT

*This article is devoted to the study of the causative relationship of a destructive person in the family, which covers the features of family and family relations, the problem of a destructive person in the family, the important aspects of the causative relationship of a destructive person. In addition, the results of the study on the degree of ulyulyative relations of spouses in the Uzbek families of the conflict are described.*

**KEYWORDS:** *Family, Attitude, Destructive Personality, Manipulation, Ulyulyative Attitude.*

### INTRODUCTION

Family sanctuary. Preserving it, fighting for its strength, the world of spirituality belongs to perfect people. After all, the family of a Hara man is connected spiritually from the moment he was born into the so-called Space. Delicate feelings: happiness, joy, joy, joy, etc., first of all, it seems to be in the bosom, with the participation of family members. Such noble relations as a warm psychological atmosphere in the family, harmony, solidarity, division are not repeated in other groups. In some families, it is necessary to maintain such purity, sincerity and develop relationships, so that each member of the family feels his responsibility and establishes mutual relations. However, in some families it is also not a secret that instead of harmony, mutual janzhal, envy instead of sincerity, cold relations are condemned instead of warmth.

There are many and different factors that cause deterioration of relations in the family. In such situations, more emphasis is placed on family conflicts, the reasons for their occurrence, quarrels in the family with a couple, parents and Children, Child-Child relations. But the fact that there is a person with a destructive character in the family, his uniqueness, the violation of relations in the family, he can be either a woman, or a man, or a brother, or a sister, or a father, or a mother,

or an aunt, a mountain or an uncle, or a cockroach remains at the second level. Psychological studies, however, show that the presence of one destructive individual in the family can lead to a deterioration of relations in the same family.

Destructive behavior has not been sufficiently studied in psychology, the meaning, causes of the concepts "destruction", "destructive attitude", "destructive behavior" have not been studied in depth.

Many researchers have focused on the various manifestations of the destruction, especially the behavior observed in adolescence, such as aggressiveness in women and men, murder, suicide, terrorist activities. According to observations, some manifestations of destructiveness were studied by a biologist, a geneticist, a psychologist, a sexopathologist, a historian, a lawyer. In view of the fact that a holistic study of the problem can help to understand its essence, the problem of destruction, destructive behavior, inadequate study of its causes and consequences, underlies the relevance of the problem.

An in-depth study of this topic, an analysis of the basis of destructive behavior and the manifestations of its various manifestations, a generalization of the world experience of solving the problem of destructiveness can provide an opportunity to curb the destructive nature of Man and create socio-psychological stereotypes that allow destructive tendencies to be directed to other spheres of activity. In the studies carried out by scientists, it was tried to assess the destructive activity of a person as a socio-psychological phenomenon. In particular, it is emphasized that the analysis of its biological, neurophysiological, psychological and social foundations can give an understanding of the essence of destructive behavior, proceeding from the nature of man.

Researcher Yu.A. In the development of his destructive behavior typology, Kleiberg notes that "the individual's destructiveness and his predisposition to destructive behavior are determined mainly by the characteristics of his individual experimental development and his direct social environment. Although it is often perceived as a devastation, now it is perceived as the innate property of every person, formed by millions of years of evolution, in conditions of a sharp struggle for existence. At the same time, the experience of the development of Philosophy, Sociology, biology, psychology, neuropsychology and psychophysiology in the 19-20 centuries led to the accumulation of facts, which allowed to argue not about this innate, but on a socio-historical issue. It is the nature of the disorder of human behavior that is formed in the process of socialization of an individual in the conditions of a historically dependent society.- based on the principle.[5]

The basis of this approach to the understanding of the essence of the destructive behavior of people is, of course, L.S. It forms the cultural and historical concept of Vigotsky.[2] He clearly distinguishes each individual from each other their biological maturity and cultural development. The first is an innate basis for the formation of personality, which can certainly not be ignored. The second is the content of personal development, formed and developed in the process of socialization, which is the result of interiorization of Real relations in the society that surrounds each person.

He is a psychologist from Uzbekistan. D. In Kadyrov's book "psychological aspects of protecting young people from destructive influences", it is desirable that the main emphasis in the process of analyzing human destructive activity is on the neurophysiological aspects that occur in the

socio-cultural context. The idea that destruction is biologically important is closer to reality than to say the main, determinant factor. In the above comments, the biological and neurophysiological basis of destructive activity is described, which is also desirable to study its psychological foundations."- argued that [14]

A person with a destructive behavior in the family can influence other members of the family in this or that aspect and undermine their spiritual world. In particular, they will also be able to influence their victim psychologically through the use of psychosocial behavior and relationships.

Psychological abuse is a type of social influence or socio-psychological phenomenon that is carried out with the aim of altering the behavior of other people for the benefit of the manipulator using stealth, deceptive and violent tactics[1]. Such methods promote the interests of the manipulator on the account of other people, thanks to which they can be considered exploitative, violent, dishonest and immoral. It is known that the social impact will not always be negative [17]. Social influence is considered harmless if there is no compulsion and respects the right to accept or refuse it.

Manipulation is one of the important aspects of simulation is that it is possible to program the behavior of an object through it. Manipulator always takes aim at the same spiritual world of man. The object of the predicate is not considered as a person. For the manipulator, it will simply be an object of influence. If a person knows the true essence of the appeals addressed to him, is aware of the hidden goals, then this situation can not be judged as a predicament. Therefore, in the case of exposing the goals of manipulation, from this time the manipulative character of the effect is lost.

The Researcher E.L. According to Dosenko, all the actions of a person can be placed along values: "value as an attitude to another - a tool as an attitude to another" [3]. The first pole (subjective) refers to the recognition of the inner value of another person, how he has the right to be. This attitude is manifested in cooperation itself, the establishment of an equal relationship, the joint solution of the problems that arise, the willingness to understand.

The second pole (objective), on the contrary, refers to the attitude of the other person in the quality of the weapon to achieve his goal, "it is necessary - use - do not need-put aside, interfere-destroy". Such a relationship can be seen in the absence of the desire to own another person, the desire to manage it, the inability to understand it, the attempt to understand it or not, stereotyped ideas, one-sided.

However, noting that not all forms of interaction between people can be attributed to these or other points, E.L. Dosenko identified the following five types of bilateral relations:

- Domination: - attitude to a partner as a means of achieving something or Goals whose interests are not taken into account; - the desire to have superiority, to manage it; - the presence of a one-sided view, stereotyped thoughts about a partner; - command, demand (violence, harassment and persuasion).
- Isolation: - attitude to the partner as a "special kind of thing", ignoring his interests and intentions; - the desire to gain superiority; - the presence of a hidden effect not directly, but indirectly associated with pressure (temptation, deception, conspiracy).

- Competition: - to look at the partner as a dangerous object; - the desire to prevail over him, - the use of both secret and open influence (some types of "subtle" manipulation, tactical agreements).
- Cooperation: - to be in an equal relationship with a partner; - the desire to prevent self-harm, without violating the interests of other people; - the use of methods of interaction [3].
- Friendship: - attitude to a partner as a person who values himself; - striving for a union, joint activity in order to achieve close or compatible goals; - the use of consensus (consensus) as the main method of interaction [3].

A harrowing type of the above-mentioned stereotyped relationship, regardless of what purpose it pursues, the main goal pursued is to influence the partner, to control it. However, in our study, since the study of the causative relationship of a person with a destructive behavior in the family was the main goal, it was investigated the degree of causative relationship on the bant scale in order to find out the predisposition of couples in disproportionate Uzbek families to causative relationship. This scale consists of 20 confirmations, the examiners express their attitude to them as 5 - almost always: 4 – often: 3 – sometimes: 2 - Random: 1 – rarely. On the basis of the points scored by The Examiner, the degree of predisposition to the manipulative attitude is determined.

A total of 86 respondents participated in our research work. The result was as follows. (Table 1)

**(TABLE 1) DEGREE OF MANIPULATIVE ATTITUDE ON THE BELT SCALE (N=86)**

	High level (80 point)	Level above the middle (60-80 point)	Lower than the middle degree (40- 60 points)	Lowdegree (Less than 40 points)
Number	17	29	24	16
%	20%	34%	28%	18%

**Picture 1**

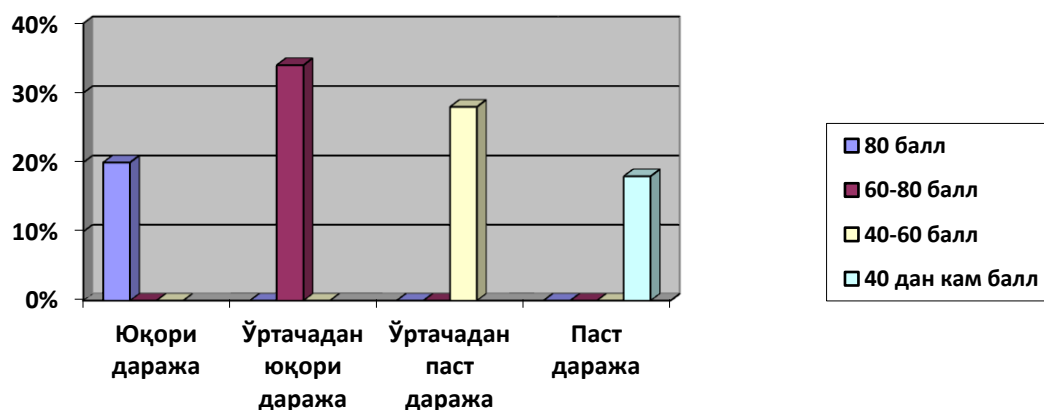

One of the main ideas of our research work is the existence of a destructive individual in the same family in conflict, disagreement and conflict in the family relationship is considered to be one of the important reasons. In a person with a destructive behavior can dominate the attitude of



vulgarity. Indeed. In our study with disputable families, it was shown that in 54% of the respondents the relationship was high and moderately high.

#### **USED LITERATURE:**

1. Bursten B. Manipulator: A Psychoanalytic View, 1973.
2. Vigotsky L.S. Hysteria razvitiya visshix psichicheskix function / / Vigotsky L.S. Patience.hair. M., 1983. T. 3. S. 5-328.
3. Dosenko E. L. Psychology manipulyasii: the phenomenon, mechanism i zatshita / E. L. Dosenko. - M.: Chero-Izdatelstvo MGU, 1997. - 344 s.
4. Zlokazov K. V. Destructivnost I lichnosti identichnost // ta filosofii i prava Ural-in Nauchniy eJegodnik. ATD - why Ras. eked. what? 2014. № 1.
5. Clayberg Yu. A. Typology destructivnogo povedeniya / / Vestn. Krasnodar. on-ta MVD Rossii. 2008. № 1.
6. Clayberg Yu.A. Psychology deviantnogo povedeniya. - M.: Izd-VA nauke, 2001. - 399 s.
7. Piz A., Piz B. Yazik vzaimootnotsheniy: mujchina-jentshina. - M.2005.
8. Bern E. Vvedenie v psichiatry I nepasvyatshennix psychoanalysis dlya. Spb.: MFIN, 1992. S.36
9. Sharafutdinova X.G. Destruction of family pelations psychoprorkophylaxis family – neighborhood educational institution. South Asian Academic Research Journals South Asian Academic Research Journals, 10 Issue 11, November 2020
10. Sharafutdinova X.G. International Scientific Journal Theoretical & Applied Science, № 08 (100) 2021210
11. Kadirov U. Some feedback on the socio-psychological structure of the individual. // Educational problems, 2012 Year, - №2.
12. Kulikov L.V. Rukovodstvo K metodikam diagnostics psichicheskix sostoyani, nastroeniy I sferi chuvstv. Apisanie metadik, instruksii PA primeneniyu. - Spb.: SPGU, 2003.
13. Crawford C. The Politics of Life: 25 Rules for Survival in a Brutal andiveive World, 2007. C: 10.5958/2278-4853.2021.00348.7

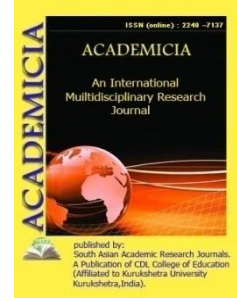

DOI: **10.5958/2249-7137.2021.01890.5**

## EYES AND OTHER FACE MEMBERS IN NAVOI GAZELLES

**Norkulova Shahnoza Tolqinovna\***

\* Senior Lecturer at Termez State University,  
UZBEKISTAN

Email id: norqulovashaxnoza8@gmail.com

### ABSTRACT

*The article focuses on the theme of the eye and other facial features in Alisher Navoi's ghazals, emphasizing the poet's skill in this regard. In Navoi's work, special attention is paid to the image of the eye, and in describing the beauty of the mistress, it is not without reason that in most cases, along with the image of the eye, it refers to other facial features. In Navoi's ghazals, the eye is described as kafir, witchcraft, Khunkhor, jayron, narcissus, star, Shahlo. Also common are images of eyebrows, eyelashes, squash with the eyes, because they are located side by side, again eye-related tears - a strong focus on tears. Attention is also paid to other parts of the eyes and face, especially the lips, mouth, eyelashes, eyelids, eyebrows, hair, face, spirit, spots, as well as stature, waist, shoulders.*

**KEYWORDS:** Eye, Eyebrow, Lip, Dumb, Spot, Tear, Pupil, Eyelash, Eyelid, Eyelid, Dur, Witch, Charos, Emblem, Idea, Interpretation, Skill.

### INTRODUCTION

In Alisher Navoi's ghazals, the definition of the eye, along with related expressions, includes other parts of the face, in particular, the lips, mouth, eyelashes, eyelids, eyebrows, hair, face, spirit, spot, as well as stature, waist, shoulders, etc. It is impossible to create the beauty, splendor, and beauty of a lover without the means that ensure the perfect exit in all respects. We also paid attention to metaphors, such as: qomat - alif; qad - cypress, beech; eyelashes - Novak, xadang; lab - la'l; hair - musk; xol - Hindu; zulf - chain, ring; pupil - the pupil of the eye; face - moon, sun; eye - star; snow - face, cheeks, temples; again in relation to the lip: flower, bud, flower, honey and honey, and b. Because the eye itself is also located on the face, the definition of the eye is expressed in partnership with other members of the face, the purpose is much clearer. Examples:

*Emas vasling tilab uchqon ko'zum atrofida kirpik,*

*Kim ul daryoyi qushlarg'a qamishdin oshyondur bu (1 – B.357).*

\*\*\*

*Ko'zum ucharui, Humoyun yuzungni ko'rgay bot,  
Biaynihi anga kirpiklar o'lmish ikki qanot (1 – B.116).*

\*\*\*

*Ko'zlarim la'lig'a hamrang o'ldi, vah ne hol ekin,  
Kim bu achchig'yig'lag'on sayi ul aylar no'shxand (1 – B.134).*

\*\*\*

*Yashirun necha ko'z solsam odamning,  
Vujudi yo'qtur og'zing bor ekan (1 – B.364).*

\*\*\*

*Tushti o't ko'nglum uyiga ohi dard olud ila,  
Ko'zda kirpik dema bu ravzan qarormish dud ila (1 – B.369).*

\*\*\*

*Ko'zUma gar kirpigim osibidin sunmas ayoq,  
Barqi ofat bu nayistonimda bo'lg'ay koshki (1 – B.392).*

\*\*\*

*Ko'zlaring qilsun hadaf, kirpiklarim etsun qalam,  
Bo'lsa do'r boista Zebo surating naqqoshig'a (2 – B.307).*

Looking at the examples, it is not difficult to observe that the definition of eye and eyelash come more side by side. That's why we decided to move on to other examples, the question naturally arises, why are the bytes not interpreted? Because we didn't feel the need to interpret or analyze them, the meaning of the bytes is already clear. Here are some examples:

*Ko'z bog'ida yuz gul ochadur ishqu lekin  
Yuzu xatidin lolavu Rayhon kerak erdi (1 – B.410).*

\*\*\*

*Ko'zga ko'nglum dardidin yig'larg'a imkon qolmag'ay,  
Tilga dardim sharhini aylarga guftor o'lmag'ay (1 – B.411).*

\*\*\*

*Necha ko'z qoni hubobidin baliyat dashtida,  
Bir yuzi gulgun g'amidin bodai Hamro ko'ray (1 – B.439).*

\*\*\*

*Ey quyoshqa ko'z qamashturg'on jamoling pargaviy,*

*Sarvi ra'noliqda xush raftor qadding payraviy (1 – B.440).*

If we do the byte analysis we gave in the example above, the page size will increase, as the content of zero bytes is known without comment and analysis, as we mentioned. Here are some examples:

*Ko'zungga tani notavonim fido,*

*Ravonbaxsh la'lingga jonim fido.*

*Labing rangi ollida qonim sayil,*

*Qadding jilvasig'a ravonim fido.*

*Belu og'zing oldi tanu jonnkim,*

*Ango oshkoru nihonim fido.*

*Bag'ir la'li, ko'z durri ollingda sarf,*

*Demaykim, senga bahru konim fido (2 – B.23).*

*Boqib dermen: shikoyat aylayin ko'rgach oni, qolmas,*

*Ko'zumga tobi nazzora, tilimga quvvati taqrir (2 – B.73).*

\*\*\*

*Yo'qki, tish siyni sitam bo'ldivu bas, ko'zda dog'i*

*Qolmadi nurianing dog'i degil ayni adam.*

*Tish iki rahnasidin hasratu g'am dudi chiqib,*

*Tutti go'yo ko'z iki ko'zgusini ZANGI zulam.*

*Tiyralik birla shikastiki tishu ko'z yo'lidin,*

*Manga yuzlandi, demak, bo'lma oni ko'rmak ham (2 – B.232).*

*Ko'zung chin g'azolivu ostida xoli,*

*Aning nafasidin topib mushki chin ham (2 – B.244).*

\*\*\*

*Zulfung ollida fusungar ko'zlaring har go'shadin,*

*Go'yi ul mushkin yilon qaydig'a aylarlar fusun (2 – B.246).*

\*\*\*

*Tifl toshidin yiqilg'on qush kibi hajr ilgida,*

*Ko'z yumub, boshim solib, og'zim ochib beholmen (2 – B.274).*

\*\*\*

*Yorab, ul yuzni dame ko'zumga pinhon aylama,*

*Yo ko'zumni andin o'zga yuzga hayron aylama.*

*Chehrasiga mezbob o'lsun ko'zum ul chehrani,  
Ko'zlarim uyidin o'zga uyga mehmon aylama (2 – B.301).*

\*\*\*

*Ko'z yoshimdin agar og'zinGDA kulgu, ne tong,  
Chun bo'lur, necha bulut yig'lasa, xandon g'uncha (2 - B.315).*

\*\*\*

*Ko'zu zulfingdin andoq kufr shoye'durkim, er hasrat  
Belin taqvig'a qilg'on mahkam el zunnorlig'larga (2 – B.324).*

\*\*\*

*Soching af'ilaridin yo'q ko'zungga hech gazand,  
Sihr ila to bu yilonlarg'a ne afsun qildi (2 -360).*

\*\*\*

*Jon rishtasidek ermas ko'zlarga beling mar'i,  
Chobuklik uchun qilding bog'larga kamar paydo (3 – B.21).*

The byte says that the waist size is made of a soul ring - a belt to make it thinner and more agile than a rope - with a belt. In the next verse, he sometimes kills with his eyes, but with his lips he gives his life, because of the joy of the world:

*Gah ko'zidin o'zturur, gohi labidin jon berur  
Sho'xlig'dindur anga har dam bu royi munqalab (3 – B.32).*

The following verse also emphasizes the eye and the lip, emphasizing that the lip is life-giving:

*Lablari xandon bo'lur, ko'rgach ko'zumda yig'lamoq,  
Ko'zlarim yig'lar, labi jon baxshida kulgu ko'rub (3 – B.37).*

An interesting and strange situation is when a lover who sees a cry in the eyes of a lover is laughing, the lover is crying again, why, the reason is the laughter on the lips of the lover's life-giving.

*Hind dedur bul ajab bozinger ul ko'z davrida,  
Hind eli ahli tamosho xayli mujgon har taraf (3 – B.166).*

Hindu has its own meanings, hindi, hindu means black, holi hindu means black, and the byte contains considerable explanations of the same meanings. Exactly the same events are carried out through word games, for example, in the first verse: the clown player dancing around the eyes is an Indian, whose dance amazes everyone. All those who watch her dance are Indians, the gang around the eyes, and the group ball is mujgon (mija - eyelashes, plural mijgon). The original target is a black, dark-skinned Indian, hence the hidden and artistic reference to the blackness of the eye and at the same time the mujgon (spot).

*Surtgandek ko'zini sarpanjasi naqshinga yuz,*

*Ko'z yorutsam ilgidin, panjamda bo'lsa ul bilak (3 – B.177).*

The construction of the above byte is similar to that of the eyes and face, as well as the wrist, the meaning of the byte is wide, the ideological world is unequal, it is said that the face the mistress who rubbed the power of her eye on the flower is incomparably beautiful. The lover's wish is the same - to hold the hand of the lover, to lighten my eyes, to touch his wrist with my fingers! This is the only dream of a lover for you, the conclusion is that the lover is ready to do all the work in love!

*Ul ishvagar chun ochti yuz, ko'zga nazar yo'q, tilga so'z,*

*Kim ashkdin bog'landi ko'z, hayrattin ul yanglig'ki til (3 – B.203).*

The lover opens his face like a nozu Nuz, so that the lover's eyes are blinded, his tongue is speechless, and the sequel ends as follows: tears close his eyes, and in amazement his tongue is like that.

*Tushti ko'z zulf ila og'zingga, ne tong,*

*Aylasa ishq vujudimni adam (3 – B.217).*

\*\*\*

*Teng ko'rundi ko'zUma vasl aro qaddu zulfig,*

*Kecha kunduzni ko'rub teng, oni Navro'z dedim (3 – B.239).*

\*\*\*

*Ko'zu o'ltursa, la'li jon bag'ishlar,*

*Ajoyib muddao izhoridur bu (3 – B.291).*

\*\*\*

*Ey Navoiy, husn elidin ofiyat yo'q, to qilur,*

*Ishvadin javru jafu ko'z, jilvadin bedod qad (4 – B.67).*

\*\*\*

*Sunbulni ko'rgach, ko'zum bo'ldi qarong'u, ey sabo,*

*Sochi mundoq tiyra yoxud sochbog'i epkinmudur? (4 – B.111).*

\*\*\*

*To xayoling ko'z dadur, ko'z uyi go'yo Ka'badur,*

*Kim turub atrofidin kirpiklarim aylar namoz (4 – B.121).*

\*\*\*

*Lablaring hajrinda jonim qasdig'a ko'z davrida,*

*Neshlardur la'lgun, mujgoni xunolud emas (4 – B.133).*

\*\*\*

*Boshimki hajr yo'lida falakdek aylandi,*



*Ko'zum yoshi erur ul charx axtari yanglig' (4 – B.166).*

\*\*\*

*Ko'zung fusungar, oning oti otashin la'ling,  
Labingda xol oning o't uzra anbari yanglig' (4 – B.166).*

\*\*\*

*Ko'zum yoruq tilar ersang, yoshurma xolingni,  
Ki ko'r o'lur yuz, agar nuqtasin nihon qilsang(4 – B.185).*

\*\*\*

*Yuzungda xol g'avg'osi aro gulguna zebidin,  
Ko'zung jayronlari o'ynarg'a go'yo lolazor etting (4 – B.196).*

\*\*\*

*Qulog'i la'li hamonoki dur ermish, chu meni  
Begunoh ayladi qatl, oni tutubdur qonim (4 – B.220).*

\*\*\*

*Bejigar bo'lsam balo tortarg'a vah emdi ne tong,  
Bordi ko'zdin chun bag'ir pargolasidin ko'yarakim (4 – B.228).*

\*\*\*

*Munosubdur ko'zum surtub, qashisam kirpikim birla,  
Qichishsa may o'tining xirqati birla kafi poyi (4 – B.330).*

In the above bytes, from the facial organs: zulf, mouth, eyes, hair, eyelashes, lips, mujgon, hol, ear, as well as from the human organs: stature, head, liver, liver, kaf (ko ' l kapi - beti), poy (foot) images are available. We will continue to give an example, but let us say that there is no need for analysis or interpretation. Now examples are given from "Badoi'ul - bidoya" and "Navodir - un nihoya" devons. In this regard, the ghazal with the radif "fido" in the "Badoyiul - bidoya" divan is carefully considered in all respects. In the first five verses of the poem, in particular, the expression of the eyes, the limbs of the face, the lips, the mouth is beautifully portrayed through a series of arts:

*Ham ramad tekkan ko'zungga jismi bemorim fido,  
Ham uchuq chiqqan labingg'a joni afgorim fido.  
Ashkkim, andin tomar giryon ko'z oning sadqasi,  
Qong'akim mendin chiqar, bu chashmi xunborim fido.  
Ul ko'zu bu labg'a umrum bog'u gulzorindag'i,  
Nargisu gulbargi yo'qkim, bog'u Gulzorim fido.  
Ko'zu og'zindin ketarg'a boru yo'q oshubu ranj,*

*Sabru ishqim sadqa, ya'nikim yo'qi borim fido.*

*Gar ko'ngul ohu ko'zung ollinda loyiq bo'lmasa,*

*Itlarimg'a bo'lsun ey sho'xi sitamkorim fido<sup>1</sup>.*

In the ghazal, special attention is paid to the image of the eye, and its unique expressions are reflected in beautiful colors. But the eye is not only the lover Tobin, but also the eye of the lover, and the eyes of the lover and the lover are compared. The first verse refers to the mistress's aching eyes and "pouty lips." In the verses, the eye is the "eye of the beholder," that is, the one who sheds bitter tears, the "gyrion eye," and again that eye is teary and bloody. One eye - narcissus, eye - sigh, eye - sick, sick, as well as the lover's lips and mouth - noisy, tumultuous, at the same time very pleasant. Lab is both a garden and a flower, zero lip is red, garden is red, flower is red, all together represent the world of redness.

We have noticed that the bytes in the ghazals, which express the members of the face, are found only in conjunction with the eye. If we put together the bytes that describe the total number of hundred members, it becomes much more difficult to arrange it. In addition, it is worth mentioning that not all the facial organs associated with the eye can be taken as an example. We have examined the ghazal verses in the devons "Badoyi'ul-bidoya" and "Navodir un-nihoya", and in most of what we have marked, the image of eyelashes, eye-to-eye mujgon is a priority. There are also separate bytes depicting the eyes and face:

*O'zga yuzga boqma deb, har bir ko'zumga bosti muhr,*

*Iynak-iynak har qaro bir naqshi xotamdur manga (Mat – 1-55).*

The "pattern Hatam" in the second verse of the byte is an inscription engraved on a seal, a seal engraved on the eye of the ring, similar to the seal in general, but in fact a stamp printed at the end of the letter instead of the signature and engraved with the name of the letter holder. It is this mark, which in the past was often affixed to the eye of the ring and worn on the hand, the eye of the ring, again the end of the ring, the last, the latter and finally the mouth, means beautiful mouth. Patterns also have their own meanings: to print a pattern - to put a flower, to draw a pattern - to draw, to throw a flower, to write, to describe, to hold a pattern - to draw, to carve and so on.

*Ne uchun bazmi visol ichinda ichmay bodakim,*

*Ko'zivu og'zi bukun bodomu shakkardur manga (Mat – 1-58).*

The understandable idea in the verse: the eye - almond, the mouth - sweetness - is discovering the meanings of sugar, in short, we are determined to summarize this chapter. But we found it necessary to add some beautiful bytes, because bytes rich in beautiful expressions always add to the mood.

*Ochding chu zulf, ul ikki ko'z har yon xadang otmoq ne tong,*

*Kim qolmish ikki turki Chin hinduyi noma'dud aro (Mat -1-61).*

\*\*\*

*Orazu xolingni biri dam ko'rmasam, ey Dilrabo,*

*O'yladurmenkim ko'runmas ko'zuma oqu qaro (Mat-1-62).*

\*\*\*

*Ul nargisi bemor ila ul g'unchayi xandon,  
Ko'zumni ul aylabtururu og'zim qurutubdur.*

\*\*\*

*Qon yoshimdin la'lgun kirpik bila aytur ko'zum,  
Orazing nazzorasin aylarda yuz til birla roz (mat -1-209).*

In Alisher Navoi's ghazals, you can find as many examples of facial expressions as you want, and the above and the following verses are a clear proof of this:

*Yuzung mehri ichinda ko'z solib og'zingni ko'rmasmen,  
Agarchi zarra Xurshid ollida ko'zdin nihon ermas (Mat – 1-219).*

In the verse, only the image of the face is given with the metaphor of kindness (Arabic) and Khurshid (Persian) and at the same time the metaphor. The lover does not look at the lover's face and see his mouth, although the rays of the sun (Mehr and Khurshid) can show even a speck to the human eye. At this point, the poet is referring to the lover's mouth (there is also a sign on the lip), his - the smallness, beauty, beauty of the mouth, it is impossible to describe more than that. In another byte, a beautiful scene is created with the help of sirishk (tears) and mujgon (eyelash - mijja) symbols:

*Sirishk ollida mujgon shoxi sanchib, betayin dermen  
Yo'lin bu selningkim, elga andin ko'p ziyon bo'lmish (Mat -1-231).*

Mujgon - eyelashes - is likened to tree branches, sirishk - tears - is compared to a flood, mujgon - to a lover, sirishk - to a lover. Sirishk - tears - flood, from it to the river - an impressive word game with the expression of "a lot of damage" to lovers is created. In another byte:

*Oh dudin, ashk qonin, nola maddin aylagil,  
Zulfi sunbul, yuzi gul, sarvi xiromoning'a arz (Mat – 1-251).*

In one byte, it is described by means of zulfi, flower face, stature, qaddi, ashk (tears). Muddao is: "oh dudin" - grassy oh (even in the dark) - to "zulfi sunbul" (zulf - kokil, sunbul - black plant), "ashk qanin" - to the face of a flower, "moaning maddin" - the longing of the moan is a silent signal to the cypress tree. The conclusion is that oh dudin - zulfi sunbul, ashk qanin - face flower (rose red, blood red), nola maddin - sarvi hromonga menzzalib, all this is laffu edition.

We have found the following bytes from "Badoyi'ul-bidoya" as an example:

*Erur ko'ngulda safo ishq toza dog'i bila,  
Nechukki ko'zda yorug'liq erur qarog'i bila (Mat -1-506).*

\*\*\*

*Davlat tongi yuziVu sochi tong qorong'usi,  
Masti sabuh ko'zlarin eltib tong uyqusi (Mat – 1-518).*

\*\*\*

*Ko'zidin to jonga etmon, la'lidin bermas hayot,  
Ul Masih o'ldim deganda tirguzir bemorini (Mat – 1-541).*

\*\*\*

*Yoshu qon ermas iki ko'zumda, balkim hajru dard,  
Qildi birin la'l koni, birni inju maxzani (Mat – 1-551).*

It should be noted that "in my two eyes" means that in one eye, the lover is in pain, in the other, in pain. Because of this, the tears that flow from both eyes are blood, so that one eye becomes a "pearl deposit" and the other eye becomes a "pearl storehouse" (treasure). Muddao from "Lal koni" is the blood of tears, Murad from "pearl store" is the white of the eye. It is a dumb metaphor and it should not be forgotten that there is also a sign on the lips, because the blood is red and the lips are red. The following ghazal bytes fully support this as proof:

*Ko'zungga tani notavonim fido,  
Ravonbaxsh la'lingga jonim fido.  
Labing rangi olinda qonim sabil,  
Qading jilvasig'g'g'a ravonim fido.  
Belu og'zing oldik tanu jonnikim,  
An(ga) oshkoru nihonim fido.  
Bag'ir la'li, ko'z durri ollingda sarf,  
Demaykim senga bahru konim fido (MAT – 2 –B.34).*

According to the byte expression, the body adjacent to the eye is the body, the lip is the blood, the lip is the blood, the waist is the fluency, the waist, the mouth, the liver is the blood of the liver, the eye. durri - eye blood, blood age finds definition. In Navoi, these examples are:

*Soching xayoli ko'zum bahri ichradur, yo ishq,  
Ko'ngul siyosatini istab, Su ichra seldi tanob (MAT – 2-B.49).*

It is easy to see that the essence of the byte is embodied in the definition of hair with the naked eye.

Throughout our observations, we have come across many bytes that have been described side by side by various other organs of the human eye.

## REFERENCES

1. Mukhammedov, M.M. (1992). Socio-economic problems of material incentives in trade (Doctoral dissertation, MM Mukhammedov).
2. Aslanova, D. Kh., Sattarova, Z. I., & Alimova, M. T. (2016). Regional tourist cluster as a tool to improve the efficiency of the region's economy. Scientific result. Economic Research, 2 (1 (7)).

3. Toirxonovna, AM, Obloqulovich, UT, & Tuychiev, II (2020). Institutional Framework for the Development of the Tourism Market. Indonesian Journal of Law and Economics Review, 8, 10-21070.
4. Toirxonovna, AM (2016). LM, Analysis of trends and forecasting the development of the international tourism market. SAARJ Journal on Banking & Insurance Research, 5 (1), 50-70.
5. Mukhammedov, M.M. (2008). Employment, living standards and government regulation of the labor market. Alimova, MT, Nasimov, AR, & Rakhmonov, SS (2020). The Methodology Of The Formation Of Tourist Clusters: The Example Of The Regions Of Uzbekistan. PalArch's Journal of Archeology of Egypt / Egyptology, 17 (7), 14462-14475.
6. Mukhammedov, M. M. Reduction of the number of labor migrants and proposals for the further elimination of labor migration.
7. Alimova, MT, Obloqulovich, UT, & Rakhmonov, SS (2020). ASYSTEMATIC APPROACH TO THE DEVELOPMEN TO THE REGIONAL TOURISM MARKET. PalArch's Journal of Archeology of Egypt / Egyptology, 17 (7), 14252-14261.
8. Mukhammedov Murod Mukhammedovich, & Turabekov Sogibjon Sherboy Uli (2017). Ўzbekistonda itisodiy ўsish suratlarini jadallashtirishning yangi imkoniyatlari. Economics and Finance (Uzbekistan), (3), 26-32.
9. Aslanova, D. H., & Alimova, MT (2020). METHODOLOGY FOR THE IDENTIFICATION OF TOURIST CLUSTERS: THE EXAMPLE OF THE REGIONS OF UZBEKISTAN. PalArch's Journal of Archeology of Egypt / Egyptology, 17 (6), 14820-14833.



**ACADEMICIA**  
**An International  
 Multidisciplinary  
 Research Journal**  
 (Double Blind Refereed & Peer Reviewed Journal)

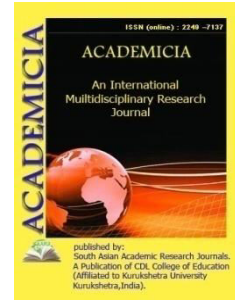

**DOI: 10.5958/2249-7137.2021.01891.7**

## RATIONAL USE OF DIFFERENT TYPES OF FEEDINGS IN THE FEEDING OF KARAKOL SHEEP

**D.M.Parmanova\***

\*PhD,

Scientific secretary of the Research Institute of livestock and poultry,  
 UZBEKISTAN

### ABSTRACT

*The article discusses the issues of rational use of pastures, the basic principles of rational use of pastures, balanced feeding of Karakul sheep, storage and feeding of Karakul sheep, a simplified two-link ten-year pasture alternation of ephemeral pastures, a simplified four-link one-year pasture. grazing ephemeral-ephemeral pastures; milk, pasture nutrition and nutrient levels.*

**KEYWORDS:** *Karakul sheep, type of pasture, pasture ration, ephemeral and ephemeral pastures, alternating pastures, breast milk, nutrients.*

### INTRODUCTION

One of the main homonyms of the rational use of Sagittarius is the ratio of the natural capacity of Sagittarius to the number of heads of animals fed in it. Therefore, in research, it is necessary to take into account the equation (balance) between the biological possibility of Sagittarius and the prime number of animals in it. Increasing the yield of the Spruce sheep depends on the state of the natural slopes and the nutritional value of the food plants. Sagittarius is the material basis and base of the productive activity of the Karakol sheep.

The profitability and ecological environment of the production of Karakol farms due to the fact that the Karakol sheep has been kept in Sagittarius throughout the year depends on the state of natural Sagittarius.

It is convenient to apply a simplified two-syllable ten-year cycle of Sagittarius for shallow-ground Wormwood-ephemeral slopes of the foothill Plains. The main principle of drawing up the Sagittarius turnover is to alternate the grazing in two seasons with greens and in the summer 4-5 years. Autumn and winter summers are grazing without exchange.



**TABLE 1.SIMPLIFIED TWO-TIER TEN-YEAR SAGITTARIUS TURNOVER OF WORMWOOD – EPHEMERAL SAGITTARIUS**

Terms of use (year)	Field Sagittarius turnover			
	The first		Second	
	Usage seasons			
	Main	Repeatedly	Main	Repeatedly
1-5	Spring	Autumn	Spring	Autumn
6-10	Summer	Winter	Summer	Winter

For efimer and efimeroid feeders, it is more convenient to use a simplified eight-year feed cycle with a blunt joint. In the southern regions, plants also grow in winter, so the main season of grazing is used every 4 years in spring and winter, without switching between summer and autumn.

**TABLE 2.EPHEMERAL-SIMPLIFIED FOUR-SYLLABLE EIGHT-YEAR SAGITTARIUS TURNOVER OF EPHEMERAL SAGITTARIUS**

Terms of use (year)	Field Sagittarius turnover			
	Main	Repeatedly	Third	Fourth
1-4	Spring	Summer	Autumn	Winter
5-8	Winter	Summer	Autumn	Spring

The ease of simplified Sagittarius turnover is due to the fact that farm buildings (kosher, greenhouse, warehouse and others) are built only in the winter storage areas of sheep.

**TABLE 3.FEEDING OF LAMBS WITH BREAST MILK, FEED AND THEIR FEED LEVEL OF SUPPLY WITH ELEMENTS**

Average living weight, kg	Milk and feed intake, kg	The composition of the received nutrients			Required by the norm of nutrition			Feed rate, %		
		Feed unit	Digestible protein, g	Replaceable energy, MDJ	Feed unit	Digestible protein, g	Replaceable energy, mDj	Feed unit	Digestible protein, g	Replaceable energy, mDj
In the period of breastfeeding (80-85 days), the summer season										
24,1	0,485	0,36	28,4	6,6	0,73	77,0	8,48	49,31	37,0	78,54
In the period of 7-7, 5 months (October-November), the autumn season										
26,7	1,24	0,53	49,2	8,0	0,81	85,8	9,44	65,43	57,34	84,74
In the period of 9,5-10 months (December-January), the winter season										
28,4	1,33	0,48	40,0	7,60	0,86	21,20	10,04	55,81	43,86	75,69

The rate at which lambs are fed with breast milk, feed nutrition and their level of supply of nutrients determines the formation of their productivity (Table 3).

Analysis of table data shows that during the period of breastfeeding of lambs (summer season), milk and feed intake is 0,485 kg, and this feed contains 0,36 units of nutrients, 28,4 digestible protein, 6,6 MDC of exchange energy. In this age period, according to the norm of nutrition of lamb consists of 0,73 units of nutrients, 77,0 digestible protein, 8,48 mDj requires exchange

energy. It can be said that Lamb is provided with 49,31% of the feed unit (37% of the digestible protein, 78,54% of the exchange energy), given the level of feed supply.

The amount of food received in the feeding of sheep in the period of 7-7,5 months (autumn season) was 1,24 kg. This nutrient, in turn, contains 0,53 units of nutrients, 49.2 digestible protein, 8,0 mDj exchange energy. To Animals of this age, in fact, according to the standard of zootechnical nutrition, it consists of 0,81 nutrient units, requires 85,8 digestible protein, 9,44 mDj of exchange energy. When calculating the level of supply of lambs with feed nutrients, it can be seen that 65,43% is supplied with a nutrient unit (57,34% of the digestible protein, 84,74% of the exchange energy).

The data obtained when the level of the feeding of Karakol sheep in the winter season (9,5-10 months) is studied show that 1,33 kg of fodder was received. In the composition of the feed, 0,48 units of nutrients, 40,0 digestible protein, 7,6 mDj stores exchange energy. By default, this period consists of 0,86 units of nutrients, 21,2 digestible protein, 10,04 mDj requires exchange energy. As a result of the analysis, it can be seen that the nutrient unit provides 55,81%, the digestible protein 43,86%, the exchange energy 75,69%.

Norms of nutrition of the Karakul Sheep of different sexes and age groups it is desirable that in females Lamb at the age of 4-8 months 0,85 units of nutrients (exchange energy 9,9 mDj, digestible protein 90 g and 1,1 kg of dry matter), 0,95 units of nutrients at the age of 8-12 months, at the age of In Rams, these indicators are characterized by a slightly higher IE 1,0 at 4-8 months; 1,3 at 8-12 months and 1,45 at 12-18 months of feed units. Norms of nutrition for breeding Ram store 1,25 mDj exchange energy, 15,0 g digestible protein and 190 kg dry matter in the composition of which constitute 1,6 nutrient unit.

## CONCLUSION

The fact that animals are not provided with sufficient nutrient elements remains from their growth and development, as well as a sharp decrease in productivity. Therefore, it is necessary to feed the animals enough in all seasons of the year. The main feature of the rational use of Sagittarius is the use of the zagon system, dividing the sheep into areas that are not large enough for him to alternately graze. As a result, the plants grow repeatedly, the level of supply of sheep with fodder plants increases. The zagon system of grazing has a prophylactic role in the fight against some diseases of the sheep. To obtain high-quality products from sheep, it is important to use them effectively during the year in order to ensure their fullness in combination with maintaining a high level of nutrition.

## REFERENCES:

1. Bobokulov N.A. Etologicheskie Osnovi I Technologicheskie priyomi povisheniya effektivnosti karakulskogo avtsevodstva. Monographs. Samarkand. "Zarafshan" 2014. 227 s.
2. Bobokulov N.A, Popova V.V, Gaziev a-training rasionalnoe ispolzovanie kormovix resource v pustinno – pastbitshnom jivotnovodstve.
3. Popova V.V, Bobokulov N.A. - Effektivnost posezonnogo ispolzovaniya I transformation pastbitshnogo korma v sherstnuyu produktiyu he Oves raznix etologicheskix tipov. J.Zooveterinaria 2013 g. s28-31.

4. Popova V.V. Effektivnost ispolzovaniya i transformation obmennoy energii pastbitshnogo korma na produktiyu he oves. Samarkand 2010, S 111414. Rakhimov A, Scarecrow, T.1967.



**ACADEMICIA**  
**An International**  
**Multidisciplinary**  
**Research Journal**  
 (Double Blind Refereed & Peer Reviewed Journal)



**DOI: 10.5958/2249-7137.2021.01893.0**

## PRIMARY VAGINAL MALIGNANT MELANOMA: A RARE ENTITY

**Rathee. N\***; **Pandey. A\*\***; **Dimri. K\*\*\***; **Gupta. N\*\*\*\***; **Suraj\*\*\*\*\***;  
**Kaur. A\*\*\*\*\***; **Rathee. H\*\*\*\*\***; **Singh. B\*\*\*\*\***

\*Junior Resident,  
 Department of Radiation Oncology,  
 Government Medical College and Hospital, Chandigarh, INDIA

\*\*Professor & Head,  
 Department of Radiation Oncology,  
 Government Medical College and Hospital, Chandigarh, INDIA

\*\*\*Professor,  
 Department of Radiation Oncology,  
 Government Medical College and Hospital, Chandigarh, INDIA

\*\*\*\*Assistant Professor,  
 Department of Radiation Oncology,  
 Government Medical College and Hospital, Chandigarh, INDIA

\*\*\*\*\*Medical Social Worker,  
 Department of Radiation Oncology,  
 Government Medical College and Hospital, Chandigarh, INDIA  
 Email id: surajbba87@gmail.com|9888377989

\*\*\*\*\*Senior Research Fellow,  
 Department of Radiation Oncology,  
 Government Medical College and Hospital, Chandigarh, INDIA

\*\*\*\*\*Senior Resident,  
 Department of General Surgery,  
 All India Institute of Medical Science, New Delhi, INDIA

\*\*\*\*\*Resident,  
 Author 8: Department of Pathology,  
 Government Medical College and Hospital, Chandigarh, INDIA

**ABSTRACT**

*Primary tumour of vagina is a rare neoplasm and known to constitute approximately (1-2%) of all gynaecological malignancies. Among vaginal tumours, malignant melanoma of vagina is known to arise from the region of atypical melanocytic hyperplasia. Vaginal Melanoma is extremely rare neoplasm and known to occur in approximately 4% of all primary vaginal tumours. Incidence of vaginal neoplasm is 0.26% per million every year globally. In term of prognosis and overall survival, Primary vaginal malignant melanoma is known to rare a very poor overall survival. Melanoma vagina is known to have early haematogenous spread and distant spread. Prognosis is very poor for vaginal melanoma due to aggressive nature of disease. Risk of distal metastatic 0.5 year overall survival 05% to 30% and chances of distant metastatic (66-100%). Thus, overall survival of primary malignant melanoma vagina is poor. We report here an unusual case of female diagnosed with primary vaginal malignant melanoma.*

**KEYWORDS:** *Malignant Melanoma, Female, Genital Tract, Primary Vaginal Malignant Melanoma, Rare.*

---

**INTRODUCTION**

Vagina is around (3-4) inches long and known to extends from cervix to vestibule. It lies in between urethra and rectum i.e dorsal to urethra and ventral to rectum. Embryologically, vagina lies dual origin i.e upper 1/3rd derived from uterine canal and lower 2/3<sup>rd</sup> derived from urogenital sinus. Primary vaginal tumours are rare condition and known to constitute nearly 1-2% of all gynaecologic malignancies. Among all primary vaginal tumours, vaginal melanoma is known to constitute 4% of all primary vaginal tumours. Incidence of primary vaginal tumour melanoma is 0.26 per million per year globally. Incidence increase as the age of females increase incidence rate were high for African-American females compared to Asian females. Vaginal melanoma is highly malignant tumour and is known to have early haematogenous spread. Vaginal melanoma usually at the time of diagnosis present as distant metastasis. Most common symptom of vaginal melanoma is bleeding per vaginum. Most common factor for development of primary vaginal melanoma is presence of pre-invasive condition. Other risk factor includes infection HPV 16 and HPV 18 is known to affect and predispose to cancerous condition. Vaginal melanoma usually appears as blackish, dark mass or ulceration.

**Case report:** A 55 years old female presented in Radiation Oncology OPD at our institute with chief complaint of bleeding per vaginum and whitish foul smelling discharge per vaginum for 2 months. Patient was apparently well when patient presented with bleeding per vaginum. It was insidious in onset, with fresh blood and clots. Patient also gave history of whitish discharge per vaginum insides in onset and discharge was associated with foul smell.

**Past history:** Patient had history of (TAH + BSO)-15 years back. Patient had history of hypertension for which she was on oral anti-hypertension drugs from part of 10 years. She has no history of DM, Asthma.

**Operation note:** Patient underwent evasion of lump from left labia major at same private hospital. After surgery patient was referred to Radiation Oncology OPD at our institute.

**CEMRI-abdomen + pelvis – CEMRI showed**

- 1) Hepatomegaly with fatty liver.
- 2) Slightly small sized left kidney compared to right side.
- 3) Mild B/L renal cortical irregularity or be due to scarring

**PET CT:**

- Non-hyper metabolic to hyper metabolic soft tissue thickening in the left inguinal region with evidence of ulceration and seroma formation-suggestion of postsurgical inflammatory sequelae.
- Mild hyper metabolism in the vagina, predominantly towards the left side of the middle.

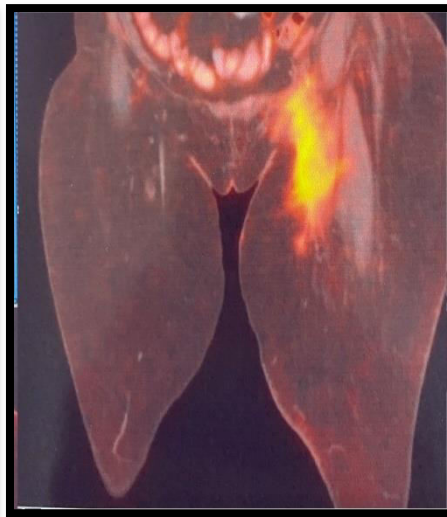
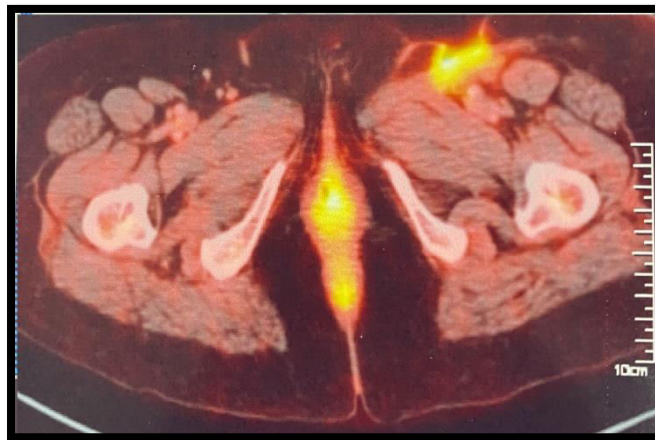
**Fig 1:****Fig 2:****Fig 3:**

**Fig 1, Fig 2 & Fig 3: Shows hypermetabolic lesion at primary site (Vagina) and hypermetabolic activity at loco-regional site.**

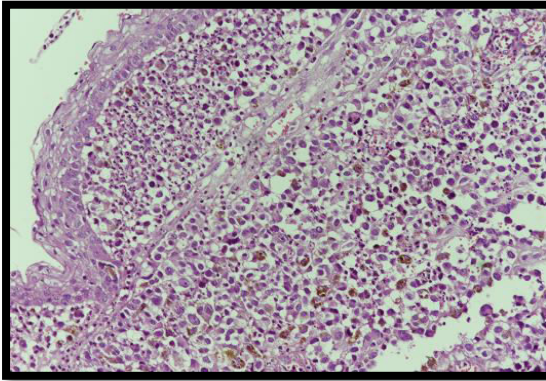

**Histopathological Examination:**

*Fig 4: 200 X tumour arranged in lobules*

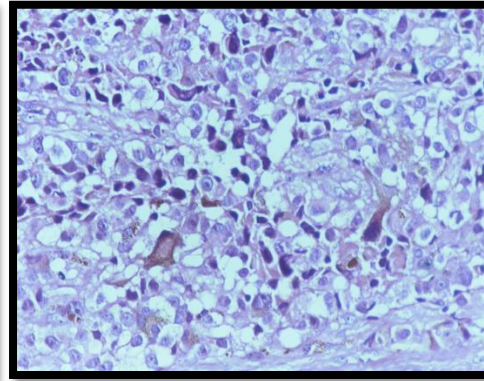
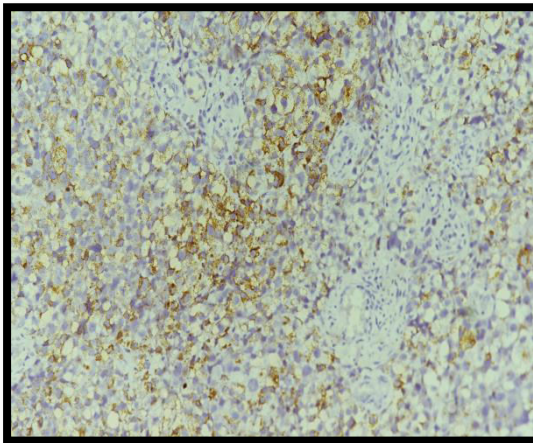

*Fig 5: 400 X and markedly anaplastic*

Showed multiple fragments which are focally lined by stratified squamous epithelium. Sub epithelium shows as tumour arranged in lobules. Tumour cell are markedly anaplastic having vesicular nuclear chromatin, prominent eosinophilic nucleoli and moderate amount of vacuolated cytoplasm with abundant intracellular and extra cellular melanin.

**Immunohistochemistry:**

**Fig 6 & 7 Tumour cells are positive for (HMB-45 AND S-100 Protein)**



*Fig: 6*

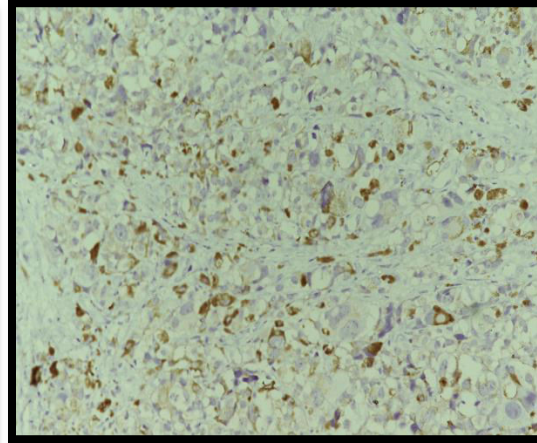

*Figs: 7*

**Treatment:**

Primary vaginal malignant melanoma is extremely rare neoplasm. So, very few studies are reported in literature for management of vaginal melanoma. Treatment approach include-surgery, chemotherapy and radiotherapy either singly or combined modality.

Primary treatment of choice for vaginal melanoma is surgery. Surgery is preferred over radiotherapy or malignant melanoma is radio resistant tumour. So, surgery is preferred option. Surgery includes radical surgery and wide local excision. There is no role for lymphadenopathy in vaginal cancer. As, lymphadenopathy ultimately leads to lymphedma which contribute to patient's morbidity. Whenever radiation is added as an adjuvant treatment modality, the dose of Radiation

is kept ranging to 50 gray to 75 gray. As melanoma is known to show systematic spread very early. So, adjuvant chemotherapy is known add some benefits in local control. Thus, Adjuvant (RT and CT) is known to shows some degree of improvement in local control. Many other targeted are also there for vaginal melanoma. These targeted therapies include.

- a) Ipilimumab (antibody against cytotoxic T.lymphocyte-associated protein 4) (CTLA-4)
- b) Nivolumab (PD-1 inhibitor)
- c) Vemurafenib (BRAF-inhibitor)
- d) Dabrafenib (BRAF-inhibitor)

-By using multiple combined modality therapy, still overall survival is very poor for vaginal melanoma. 5year overall survival rate is 5-30%.

### **CONCLUSION:**

As vaginal melanoma is very rare (extremely rare) tumour. Overall incidence is first 0.26 per million per year globally. Cancer is most seen in females of older age compared to younger. Females of Africa and America are commonly affected compared to Asia. As, vaginal melanoma is highly malignant tumour and known to show distant metastasis at early age. So, Aggressive treatment approach is very required. Treatment approach includes surgery, chemotherapy and adjuvant radiotherapy. Even after continued modality and aggressive therapy approach, overall 5 year survival is very poor 5-30%. The risk of distant metastasis is around (66-100%). As, primary vaginal malignant melanoma is extremely rare neoplasm and overall risk of distal metastasis is high and prognosis is very poor. There is no clear guideline for treatment of vaginal melanoma. So, further reports of such rare cases 1% in literature us of paramount important to guide the disease risk factor, prognosis and treatment.

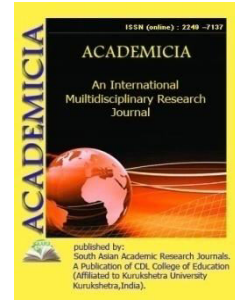
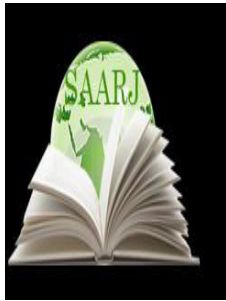

DOI: **10.5958/2249-7137.2021.01892.9**

## USE OF "YOU" AND "YOU" (POLITE FORM) PARABLE IN COMMUNICATION BEHAVIOR BETWEEN UZBEK AND GERMAN FAMILIES

**K. Kakharov\***

\*Teacher,  
FerSU, UZBEKISTAN

### ABSTRACT

*This article analyzes the socio-linguistic aspect of the use of the pronouns "you" and "you" (polite form) in the communication behavior of Uzbek and German families.*

**KEYWORDS:** *Communication Behavior, Family Relationship, Parent, Spouse, Child, Relative, Etiquette, Ideal Couple, Senility And Intimacy.*

### INTRODUCTION

It is natural that the communication behavior of the peoples of the world differs from one another in terms of region of residence, race, nationality, and belief. That is why philologists of the world pay special attention to this issue. In this article, I will try to socio-linguistically analyze the use of the pronouns "you" and "you" (polite form) in the family relations of the Uzbek and German peoples, which are far from each other in above mentioned terms.

The Explanatory Dictionary of the Uzbek Language defines "you" and "you" (polite form) as follows:

“You” is a personal pronoun, a second person, a singular.

1. It is used to refer to someone who is close to you and younger than you.
2. Indicates rudeness or disregard in addressing many.

“You” (polite form) is a personal pronoun, a second person, a plural.

1. It is used in public address.
2. It shows respect for someone older than you and for anyone in general.”<sup>1</sup>

The German Explanatory Dictionary explains these words as follows:

Du zueinander sagen (you say to each other):

- Mitglieder einer Familie und Verwandte untereinander (between family members and relatives).
- Freunde untereinander (between friends).
- Erwachsene zu Kindern und Jugendlichen (unter ca.16 Jahren) (adults to children and young people (those under 16)).
- Studenten untereinander (among students).
- Arbeitskollegen untereinander, sofern sie dies vereinbart haben (between colleagues, by mutual agreement).
- Kinder und jüngere Leute untereinander (z. B. auch im Sportverein, beim Militär) (among children and young people, for example, in a sports team, in the military).
- In Gebeten wird auch Gott mit du angeredet (in prayer Allah is also referred to as "you").
- Sie zueinander sagen: (You (polite form) say to each other)
- Erwachsene untereinander, sofern die Anrede mit du nicht ausdrücklich vereinbart wurde. (Among adults, if your application is not agreed)
- (Vorgesetzte / Mitarbeiter, Lehrer / Schüler, Professoren / Studenten usw.) (Chairman / colleagues, teacher / student, professor / student, etc.)
- Kinder und Jugendliche zu Erwachsenen, wenn sie nicht verwandt oder befreundet sind. (Children and young adults are older than adults if they are not relatives or friends.)<sup>2</sup>

Apparently, the explanatory dictionary of the German language gives more detailed description of the pronouns "you" and "you" (polite form) than the explanatory dictionary of the Uzbek language. The Uzbek dictionary does not mention the relationship between "you" and "you" (polite form) in the family, but the German dictionary states that "you" is the norm between family members and relatives.

In both languages, Allah is referred as "you" while praying, but this is not taken into account in the Uzbek dictionary.

Of course, it is not uncommon for German people to address to each other as "you" from the first time they met. They offer to switch to "you" only after they have met each other several times and a friendly relationship has developed. As a proof of our point we can cite the following opinion of the German writer Thomas Mann: "The fact that two complete strangers address to each other as "you" is a sign of savagery, backwardness, impoliteness. I really loathe it. Because, in essence, it is arrogantly and unscrupulously directed against civilization and humanity"<sup>3</sup>

A.Knigge, a German cultural scientist, emphasizes that the moral norms in the family are constantly changing, and that today's norms are not the same with the ones from the past.<sup>4</sup> Because in the past, in German families, children used to address their parents "you" (polite form), and today we can see that this habit has completely disappeared.

According to our observations, we cannot say that all German families in Germany treat each other as "you". In some cases, we even observed that the couple called each other "you" (polite



form) during their life. We witnessed it among families which have been living in Germany for more than a few centuries, but originated from other nationalities or countries. In such families, it is traditionally inherited from generation to generation for a couple to say “you” (polite form) to each other.

But today, we know that in German families, it is normal for couples not only to address to each other "you", but also they share household chores.

- Gestern habe ich gekocht, heute kochst du (I cooked yesterday, but you will cook today).
- In der vorigen Woche hast du die Zimmer saubergemacht und in dieser Woche mache ich die Zimmer sauber (Last week you cleaned the rooms, but this week it's my turn to clean).
- Ich bügele heute die Wäsche und morgen bügelst du (I will iron the clothes today, and tomorrow you will iron them).

If a husband and wife do not have the same approach to house chores or if their interests do not match, their marriage may soon fail. We can see this for German families in the story of "Das Idealpaar" by the German storyteller Leonhard Toma:

“Also, Meike und Torsten, die zwei... einfach ideal! Ihre Hobbys, ihre Interessen, fast identisch. Beide reisen gern, beide sind Naturfreunde, und beide gehen gerne aus: ins Kino, ins Konzert, ins Restaurant.

Er liebt italienisches Essen, sie auch. Beide interessieren sich für moderne Kunst. Sie mag Picasso. Er auch. So viel gemeinsam! Einfach perfekt!

Natürlich gibt es auch Unterschiede. Aber das macht ja nichts. Das ist absolut normal. Er mag Krimis. Die gefallen ihr nicht so. Auch mit den Berufen ist das so: Er ist Lehrer am Gymnasium und hat immer lustige Anekdoten aus der Schule. Sie ist Journalistin und trifft oft interessante und wichtige Persönlichkeiten aus Politik, Sport und Kultur.

Manche Unterschiede sind sogar komplementär.

Er kommt früh nach Hause und kocht gerne. Sie kommt später und spült gerne ab. Aber sie hasst Bügeln, und ihm macht Bügeln richtig Spaß. Fantastisch, oder?

Auch ihre Stärken sind komplementär, sie ergänzen sich wirklich super. Sie ist Informatikexpertin, er ist bei Computern immer noch ein totaler Anfänger. Aber er kann Regale zusammenbauen und Fahrräder reparieren, und da hat sie zwei linke Hände.

Also wirklich: wie Yin und Yang, die beiden!“<sup>5</sup> (Mike and Torsten, they are an ideal pairs! Their hobbies and interests are almost the same.

The guy likes Italian food, and so does the girl. Both are interested in contemporary art. The girl likes Picasso. The guy too. So much in common! Simply great! Of course, there are different sides. But it doesn't do anything. This is normal. The guy likes crime movies. The girl doesn't like it very much. The same is true in their professions: the young man is a teacher in the gymnasium and has been telling funny stories from school. The girl is a journalist and often meets important people in sports and culture, politics. Their strengths are also noteworthy; they really complement each other. The girl is a computer scientist and the boy is just starting to learn computers. But the guy can make furniture and repair bikes. The girl is lucky in this regard.

They are really like Yin and Yang (like Tahir and Zuhra)

In the story, the author points out that in German families, couples should help or complement each other in doing household chores. This is completely unacceptable for Uzbek families. Scholar and poet Siddiq Momin describes in his humorous poem "Village Woman" that Uzbek women work with gratitude and devotion for their families and consider it their duty:

(A village woman with forty souls,  
He is not satisfied with that either.  
If you break it,  
"Ooops," he said, and he would not die ...  
Achieves everything,  
Serves everyone at home,  
Although she is a brave woman,  
"Ooops" he said, and he would not die ...)

In addition, the author sings about the fact that rural women, having a large family, bake two loaves of bread every day, send their family members to work, kindergarten, school, welcome guests and use the usual phrase "Woe is me" in their speech. After reading the story of the German writer Leonhard Thomas above, we can see from the passage in the poem of the poet Siddiq Mumin that women in Uzbek families deserve recognition when they understand the equality of a woman typical of German families in doing household chores.

In the Uzbek speech etiquette, the primary nomenclature is based on the age of the speakers: father, mother, grandfather, grandmother, uncle, aunt, uncle, uncle, brother, sister. In the Uzbek people, it is the norm for parents to address their children as "you", and for children to treat their parents and all their relatives as "you" (polite form).

- (Uzbek mother): Who forced you?
- (Otabek): You (polite form), mother! (A. Qadiri, Bygone Days)
- (Kumush): How many times have I told my father and you (polite form): I do not want this job anymore. (A. Qadiri, Bygone Days)

The first piece of text is from a conversation between the mother's son (Otabek) and the second with the mother's daughter (Kumush). This form of appeal is not territorially or ethnically limited, but is common to the entire Uzbek nation.

The etiquette of German families is that children should address their parents, aunts and uncles. This situation symbolizes mutual closeness and respect.

- (Tochter): Kannst du mir helfen, Mutti? (Girl: Mom, can you help me?)
- (Sohn): Vati, ich habe alles gemacht, wie du gesagt hast. (Son: Dad, I did everything as you said.) / Tangram Deutsch als Fremdsprache /



- Wo warst du, Melanie? Wir haben uns lange nicht gesehen. (Where have you been, Melanie? We haven't seen each other in a long time). / Moment mal! Lehrwerk für Deutsch als Fremdsprache /
- Peter, wie hast du deinen Urlaub in Griechenland verbracht? (Peter, how did you spend your vacation in Greece?) / Moment mal! Lehrwerk für Deutsch als Fremdsprache /

In the first example, we can see the daughter's mother, in the second case, the son's father, in the third case, the niece, and in the fourth case, the niece's uncle. We can see that such cases do not violate the norms of German speech etiquette, and express mutual intimacy and respect.

“The more diverse the nature of the world, the more diverse the ethnic composition of the population. can produce.”<sup>6</sup> The relationship between "you" and "you" (polite form) in Uzbek and German families, which are religiously and culturally distant from each other, as well as gender inequality in the family, is based on the literature of the two peoples, the development of education between the two countries. We can find out through economic and diplomatic relations.

#### REFERENCES:

1. Götz D., Haensch G., Wellmann H. Großwörterbuch Deutsch als Fremdsprache. – München: Langenscheidt, 2008. – S.281.
2. Hans-Michael Klein. Knigge kinderleicht: Benimm für Kids. – München: Circon, 2010. – S.112.
3. Мўминов С. Ўзбек мулоқот хулқининг ижтимоий-лисоний хусусиятлари. – Фарғона: Classic, 2021. – Б.30.
4. Leonhard Thoma. Das Idealpaar. – München: Editorial Idiomias, S.L. Unipersonal, 2007. – S.3.
5. Сиддиқ Мўмин. Эъзоз. – Тошкент: Akademnashr, 2015. – Б.119.
6. Ўзбек тилининг изоҳли луғати. 5 жилдли. 1- том. – Тошкент: “Ўзбекистон миллий энциклопедияси” Давлат илмий нашриёти, 2006. – Б.680.
7. <https://yoshlikjurnali.uz/tarjima/axloq-va-hayot-bir-butundir/>

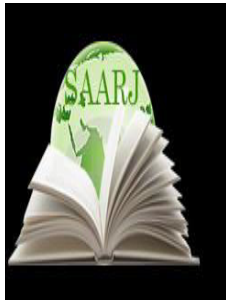

**ACADEMICIA**  
**An International**  
**Multidisciplinary**  
**Research Journal**  
 (Double Blind Refereed & Peer Reviewed Journal)

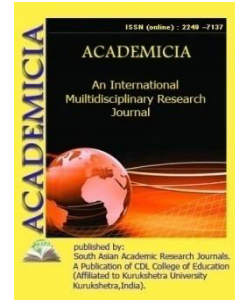

**DOI: 10.5958/2249-7137.2021.01895.4**

## EXISTENCE AND ITS COMPONENTS "A NEW APPROACH"

**Abdukhalikov Safar\***

\*Professor of the University of Public Security,  
 Doctor of philosophical sciences,  
 Under the National Guard of the Republic of UZBEKISTAN

### ABSTRACT

*This first article, which consists of a series of articles, highlights the doctrine of existence (being), social existence, cultural existence, substance, the law of social consciousness, the dialectical and cultural interpretation of the history of the legal culture of society and its methodological significance in understanding the laws, including the right to freedom of thought.*

**KEYWORDS:** *Existence, Social Existence, Dialectical And Culatural Interpretation Of The History, Cultural Existence, Substance, Social Existence, Social Mind, Legal Culture Of The Society, The Right To Freedom Of Thought.*

### INTRODUCTION

**The notion of existence and its structural components.** The universe as a whole has a specific system and general laws of relativity. It is the subject of general philosophy as an object to be studied by its common regulations. The general teaching, that is, social philosophy studies society and, in other words, social life, or social existence, as an integral part of a whole existence, and relies on general philosophy. General philosophy consists of a unity of ontological and dialectical teachings about existence. The issue of existence is the primary and central worldview division that determines the existence of different forms of thinking at all levels.

Existence means being. As a general philosophical concept, it contains the whole world and all existences in it, consisting of things, events and processes. Consequently, the world, the matter, events, and processes in it, have a common unity and common connection with all their properties, which is expressed in the category of being. Knowing an entity as a whole system of parts, including the general existence, is of the importance of worldview for the scientists studying each specific field and object.

It is well known that dividing the existence into parts, and putting a “Chinese wall” between them, is relative. In our view, existence is essentially composed of natural (1) and social (2)

(which means society or social life) beings. It is also divided into material (1) and spiritual (2) existences if it can be recognized as having an onto functional state. According to its dialectical development, a part of a material existence is also an integral part of a social existence. Similarly, a certain part of spiritual existence is an aspect and a regulatory process of nature (for example, the psyche of animals) and the rest of the higher part of society (at this point it can also be called a spiritual existence).

Like a natural being, a certain part of social existence is a material being, that is, matter. In a natural being, the material existence is thought to be the main and the first element. But the material component of social existence is inextricably linked with human mind. Because the socio-material existence consists of cultural and non-cultural parts, in which the former determines the onto functional state of the latter. And because the first part of social existence, which is the material cultural component, is established through human mind. This is the main difference between natural material existence and social material existence. In the same way, like a certain part of a social existence, the second part of a natural existence is a spiritual existence. The second part of the natural existence is the psyche of animals. The concept of “spirit” refers to the spiritual existences of animals and humans. The animal psychic world is indeed a higher component of the natural existence, which is explained by the existence of the first signal system and the absence of the second signal system which consequently means the absence of abstract thinking.

Social existence is divided into cultural existence and non-cultural social existence according to its ontological state, and according to the state of functioning, it consists of the material, spiritual and political-legal life of man and its social units. Cultural existence is a part of humans' existences as it is created by them to process reality in order to maintain their own existence. With the emergence of a cultural existence, a society is formed, and with its development, the history of the individual develops. It forms the core of society. Depending on it, the next parts of society emerge. Such an approach to social reality is dialectical and cultural understanding of history. If we look at society, from a historical point of view in terms of a dialectical cultural understanding, we see that the first, a certain part of them, is divided into cultural and the second part into non-cultural aspects. In this case, material culture is the basis of material life, political and legal cultures are the basis of political and legal life, and spiritual culture is the basis of spiritual life. It is evident that in this case matter as a material existence and the soul as a spiritual existence are the basic links that connect natural and social existences. The cultural parts of the spheres of social life form cultural existence as a whole system, on the basis of which the existence, essence and functioning of the social existence are determined. Cultural components of the spheres of cultural life form cultural existence as a whole system, and the existence of social being, its essence and functioning are determined on this basis. In addition, it should be noted that the general laws and driving forces of social life also stem from this foundation, that is, the cultural existence which is thought to be the central part.

**The unity of social existence.** F.J. Engels wrote, “The true unity of the universe lies in its materiality, this is proved not by a trickster phrase or two, but by the long and difficult development of philosophy and nature.” This idea is one of the conclusions about the unity of the universe. People, thinkers, have long sought to find connections, commonalities, between things and events throughout historical development. The development of the natural sciences plays an important role in substantiating the material unity of the universe. We have said above

that existence is divided into material and spiritual parts. This type of dividing is relative, and the spiritual existence is one of its processes arising from the inherent connections, interactions and the connections of the material existence. In order to determine the specificity of mental and then ideological processes, it is necessary to separate them from material existence. However, spiritual existence is one of the properties of material existence. Hence, a certain part of the properties of material existence is transferred to spiritual existence and vice versa, spiritual existence is transferred to material existence.

And the unity of a social existence lies in the interdependence of its cultural parts. The cultural parts of social existence include knowing the person and his own needs and interests in the substantial-ontological aspect, directing their activities to specific goals in order to meet these needs, and then realizing the products of activity. Satisfaction of a need and its processing ensures the essence of the cultural existence and then the unity of the existence of the social being and its continuous and uninterrupted processes. The cultural components of social existence are a single correlation unity of social, material, spiritual and political-legal cultures as they maintain the unity of social existence in relation to social location and time. Hence, the unity of a social existence lies in its cultural parts.

The core of a cultural existence is people. Human beings, are not only the central part of a cultural existence, but also its subject and social carriers. Because human creates it by processing and transmits it from generation to generation. In this way, people act not only as the main carriers and subject of cultural existence, but also of social existence in general. Humans are concrete (certain), not abstract, but biosocultural beings. At a certain stage in the development of a existence, its social form, that is, a social existence, emerges. It is a biological existence, that is, a sub form of human existence, that is, a natural existence, including itself, as a result of man's transformation into a biosocial, that is, cultural existence, that is, a human existence. But people carry out their activities in "communities", which are their social units that is, in the framework of which they are gathered, assembled, because they are born, formed and live in a "community". Simple aspects similar to the condition of such people also exist in the plant and animal world. Any plant or animal species grows and reproduces in its own specific "community". Take, for example, the "community" of bees. Whether it is a plant or an animal, or a human "community," it provides the interactions of its members with the environment. On the contrary, unless the members of the "group" are interconnected, their team cannot be formed. A community of plants and animals is formed and operated only when certain climatic, geophysical and biotic conditions are present. Community in animals is much higher in quality than in plants. In the human community, the general laws specific to the animal community are manifested in a high form. Hence, a community of people, a social existence, exists only in relation to a natural existence. Human body and the natural changes in it act as an integral part of the natural being. But the essence of human is determined by his civilized part. This civilization takes place in his "team". It follows these philosophical analyses that the "community" of human existences is also a continuation of the "communities" inherent in natural existences. The "community" takes the form of a "society", reflecting stability and permanence in relation to the world of people. The concepts of "social life", "social existence" are related to the concepts of "biological life" and "natural existence" and are synonymous with the concept of "society". In the scientific literature, the term "society" is, firstly, an integral part of existence, that is, a social existence, secondly, a specific whole of social life, thirdly, people's past, present and future lives, and fourthly, its

specific historical significance in terms of specificity represents the common societies of a number of people, such as primitive, slavery, feudal, capitalist, totalitarian, communist societies, fifthly, societies specific to certain regions (e.g., societies in Central Asia), and sixthly, civil societies in relation to human activities. We used the term “civilizations” to mean a country with its own state and citizens. It is clear from the above given descriptions that the concept of “society” embodies the dialectic of the transition from general to specific and from it to individual. So society has concrete views, not abstract ones. We have said above that the civilization of humanity, its transformation takes place through “communities”. Nation is one of such “communities”. Today, 37 countries around belong to one nationality with only 5 percent of the world’s minorities.<sup>3</sup> But there are also multinational countries like Albania, Armenia, Barbados, Hungary, Ireland, Yemen, Malta, Poland, Jamaica. A national country is a certain view of society as a whole. When a nation is independent, it determines its own destiny on the basis of a social entity that has a certain historical structure. In particular, it adopts its own laws based on its own needs and interests. The Law of the Republic of Uzbekistan “On Freedom of Thought and Religious Organizations” adopted by the Supreme Council of the Republic on June 14, 1991 or the Criminal Code of the Republic of Uzbekistan adopted on September 22, 1994 can be an example of this.

The transition from the concept of “existence” to the concept of “social existence” and to the concept of “cultural existence” is in fact a transition from the first order of abstraction to concreteness (certainty) in the knowledge of social phenomena, including criminal law and the right to freedom of thought. Moving from a second-order abstraction to a certain one in the knowledge of social phenomena, including criminal law and the right to freedom of thought the transition from it to the concept of “human” and “community”, including “nation”, interpreting the social being as a whole organism, that is, society. Analysis of social phenomena from the abstraction of the first and second order to the concrete allows to move from the concept of cultural being to the concept of legal culture and from it to the concept of criminal law and the right to freedom of thought and to clearly see their social basis. Thus, the onto functional state of the Criminal Code and the Law on Freedom of Thought and Religious Organizations in the system of existence has the following microelemental nature in relation to existence: existence (whole); social existence, which is society (part); cultural existence, including man and community (megaelement); legal culture (macroelement); the Criminal Code and the Law on Freedom of Thought and Religious Organizations (microelements). Again, in this case, the nation acts as one of the types of community, that is, as a mega element. Thus, the Criminal Code, the Law on Freedom of Thought and Religious Organizations act as a microelement in relation to it in the system of existence. These laws are also dominated by, firstly, the general laws of existence in general, secondly, the general laws of social existence in particular, the laws inherent in cultural existence, and thirdly, the general laws of legal existence, in particular legal culture.

Hence, the teaching based on the dialectical cultural understanding of existence described above serves as one of the general philosophical ontological methodological foundations in the way of thinking about the study of social phenomena, including criminal law and the right to freedom of thought.

Different areas of cultural existence have emerged from the diversity of human needs. Social units of people and its aspects which are material, spiritual and political-legal culture are thought



to be the main areas of cultural existence. Based on these types of cultures, the spheres of social life as the material, spiritual and political-legal spheres of social units of people are originated.

Thus, the cultural existence consists of the social units of people and its aspects, that is, the correlative-functional integrity of material, spiritual and political-legal cultures, and forms the basis of social life.

From these methodological teachings, the following conclusions can be drawn in relation to the object we are studying, that is, the people create their own legal laws based on their needs and interests. The Law of the Republic of Uzbekistan “On Freedom of Thought and Religious Organizations”, adopted by the Supreme Council of the Republic on June 14, 1991, was made up in such a cultural way.

Cultural existence as a substance. The functional states of things and events derive from their essence and are determined by them. In particular, the functional status of the Law on Freedom of Thought and Religious Organizations stems not only directly from the nature of the real legal culture, but also from the content and essence of the whole cultural entity and its components. In this case, a whole cultural entity has a defining property as a substance.

Reality cannot exist without substance. Substance is, firstly, the substrate (which means “basis” in Latin), the carrier (which means owner, “nositel” in Russian,) and, firstly, the internal causes and attributes specific to all areas of reality or any whole, thirdly, the substrate and the sides and including laws of internal nature between the parties. The internal unity and change of the whole does not occur without it. If we apply the substantive part, the connections, to the cultural existence, then, firstly, its own substrate, its inner owner, and firstly, its internal aspects or attributes, such as man, secondly, need, interest, thinking, knowledge, evaluation, purpose, plan, activity, and activity products; thirdly, we see that the substrate is human and attributes, there are essential connections between attributes, laws. Hence, a cultural existence can be considered as the basis or the substance of social life. Also, looking at a cultural entity as a substance allows us to determine whether it has certain quantitative and qualitative characteristics specific to the state of a whole substance, genetic interactions between its substantial elements or attributes, structural integrity, functional interdependence of elements and causal conditions.

Cultural existence (as a substance) is the substantial basis of all social phenomena, including the Law on Freedom of Thought and Religious Organizations. This law is the side of legal culture, and legal culture is the side of cultural existence. Thus, the Law on Freedom of Thought and Religious Organizations functions as an element, and not towards cultural entity. The general cultural laws inherent in cultural existence determine the existence of laws relating to the right to freedom of thought and manifest themselves in a specific form.

Thus, the material, spiritual, and political-legal cultures that form the basis of people’s social unities (social culture, if we can say in cultural terms) have their own internal commonalities (substantial foundations), which constitute the substantial integrity of a cultural existence; the other side of the whole of existence defines a correlative-functional unity. And conversely, the correlational integrity of a cultural existence ensures its status as a substance in social life. Hence, the substantial and correlational aspects of a cultural existence complement each other.

Thus, the substantial unity of a cultural being is the deepest moment, the side, the core, the decisive and defining side of its correlational whole. The correlative integrity of a cultural



existence is broader and richer than its substantial integrity. The analysis of a cultural existence as a substance makes it possible to enlighten not all aspects of the correlational content, but the main decisive core part. The study of the correlational integrity of a cultural existence in cognition, on the other hand, fully and concretely clarifies certain aspects of its substantial integrity. The basis of the substantial integrity of a cultural existence is its substrate which is human. The fundamental cultural changes in humanity lead to changes in the cultural existence, and the radical qualitative changes in the cultural existence lead to changes in social life. Thus, radical qualitative changes (these changes are in fact determined by the real social being that exists, including the real cultural being, qualitative changes in religious culture, science, and practice play an important role in this) in the level of religiosity or atheism in a person lead to changes and improvements in one or another part and article of the Law on Freedom of Thought and Religious Organizations, which has its place in the correlation system.

The two concepts of the law of social existence defining social consciousness and its methodological significance in the study of the right to freedom of thought. The law of social existence that determines social consciousness forms the basis of all his works by K. Marx and F. Engels described their materialistic understanding of history. But the definition about social existence given in I.V. Stalin's work titled as "On Dialectical and Historical Materialism" is still based on the literature of all the social sciences. In this work, social existence is mirrored by the material living conditions of society, the mode of production, the population and the geographical environment. The study of the concept of "cultural existence" in the ontological aspect requires clarification of its relationship with the category of "social existence".

There are two concepts of social existence to date, those based on a materialist understanding of history and those based on a dialectical cultural understanding of history. The first of these is, historical materialism has taken an authoritarian place from K. Marx's time onwards. The second is taking shape. It is well known that the law of social existence that determines social consciousness is the basic law of the materialist understanding of history. But this law manifests itself differently in dialectical cultural understanding. It is therefore important to distinguish between the dialectically materialistic and the dialectically cultural notions social existence.

In the history of historical materialism, there were relatively broad and narrow understandings of social existence. For example, V.P. Tugarinov stated as, "The basis of social existence is production, economic activity indeed..., social existence includes many other spheres or forms of practical social life, including class, national, political, family and other relations ...

By social existence we mean all the real practical life and activity of people."<sup>4</sup> It is true that the definition of this social existence encompasses whole real practical life. But the core, the central part of social existence, remains unclear. In the former Soviet scientific and philosophical literature, D.I. Chesnokov, on the other hand, understood social existence in a narrow sense, in the context of economic relations, "The interaction of the basis with social ideas and theories is reflected in the interaction of social existence and social consciousness. The concepts of "basis", "material social relations", "social existence" are concepts of the same order.

We use the concept of "basis" when we look at the defining role of the relations of production in relation to all its superstructures as a whole or in relation to its organizations and institutions. And we use the concept of "social existence" when we look at the relation of the basis to ideas and theories, and to social consciousness in general."<sup>5</sup>

The distinctive definitions of social existence given by the J. Boboev, Y.K. Pletnikov, A.Kh Qosimjonov, M. Fayozov in the seventies, eighties and nineties of the last century are almost repetitive, close and common to each other. J. Boboev stated as, “social existence is a dialectical unity of objective material relations of people and material conditions of life, where the mode of production plays a decisive role.”<sup>6</sup> It is clear that this definition covers only the material aspects of social life, and the method of production is the basis of social existence. If Y.K. Pletnikov defines social process as a process of material production, which is taken as an objective reality<sup>7</sup>, A.Kh. Kasimjanov depicts social existence as “the material relationship of people to nature and to each other, which is formed by the decision of human society and exists independently of social consciousness.”<sup>8</sup> This definition is stated by M. Fayozov as, “Social existence represents the material relations of people to nature in the process of production of material wealth and the interactions, connections, relationships formed between people in the process of material production.”<sup>9</sup> All of these definitions of social existence based on a Marxist, materialist understanding of history, explained by I.V. Stalin is concretized in one form or another.

According to the dialectical cultural understanding of history, social existence is an integral part of existence, society, or in other words, social life, the central part of which is a cultural existence. The content of a social existence can be determined only through its component, that is, social consciousness, including its attitude to thinking.

All forms of cultural existence occur through the basic element of spiritual culture, that is, human thinking. We do not want to exaggerate the role of historical figures but we believe it is necessary to tell the historical truth. If the social cultural existence and the social civilization emerged on the basis of K. Marx’s thinking, then the creation of a cultural existence, the foundation of our future civilization for the future of Uzbekistan, began under I.A. Karimov’s leadership. It goes without saying that for the development of thinking it is necessary to develop a creative environment, which is one of its regulatory. For example, in the Renaissance in all regions, the equal study of religious and secular knowledge, the possibility of comparison, led to a dialectical debate, that is, an active creative environment. Human, with the thinking as the core and subject of cultural existence, acts within certain, real conditions, including real interests as a factor.

Commonness is decided on the basis of singleness. We say that no matter how prevalent universalism is in a cultural existence, its origin and direction depend on the concrete, real, regional and national foundation (base). Human thinking is therefore national as a cultural perception. It is based on a real social existence. In historical materialism, social existence is recognized in a narrow sense, that is, in the sense of the material conditions of social life. In I.A. Karimov’s works, however, a real social existence as a real existence in relation to time is understood to consist not only of material, but also of social, political, legal, and spiritual conditions. Because the historically formed socio-psychological situation, experience and theoretical knowledge itself are among the spiritual conditions for the further continuation of the thought process.

Hence, a social existence contains cultural existence, including a historically constructed spiritual culture, and the ongoing process of thinking (which is contemplation in action) on the basis of a real historically constructed real social existence determines all subsequent types of cultures. But in this case the cultural aspects of material, social, political and spiritual life, that is, all types of cultural existence, form a whole system with correlation with each other. Thus, the

main task of the leadership of the Republic of Uzbekistan is to create a cultural entity in a particular system. At the same time, it is necessary to take into account, first of all, the real social existence of Uzbekistan. This theoretical problem is enlightened in detail in the chapter titled as “The conditions and grounds of our own path” in I.A. Karimov’s book, “Uzbekistan’s own path to independence and development”.

The first President I.A. Karimov’s choice of the path of the future of our independent republic was based on a number of features and conditions of its real social existence. At the same time, the national-historical way of life and thinking of our people, national traditions and customs, the specific demographic situation in the republic, national composition and internal national relations, geostrategic position, dialectical connection and adaptation of our society to real natural climatic conditions, protection of political and economic independence factors such as the existence of sufficient potential, the formation of a certain social consciousness of people with certain values in recent years were taken into account.<sup>10</sup> As our final goal is to build a democratic society with a free market economy,<sup>11</sup> the five rules of transition to it, and “the Strategy of Action” elaborated by Sh.M. Mirziyoev, the President of the Republic of Uzbekistan, have become the principles of a single mechanism, cultural and legal tendencies, or more precisely, the social existence of our lives. And now the next continuation of thinking of our people is determined by the real social existence created during these years of independence.

Thus, if a social being has only the material conditions and aspects of society according to a materialist understanding of history, in the dialectical cultural understanding the history, it is the real social existence, that is, the social units of people and the spheres of material, spiritual, political and legal life created by them, including their aspects, tendencies, processes and laws. Historical social consciousness, yesterday’s social consciousness of people, will have become an integral part of social existence in today’s life. Therefore, the law of the defining role of the social existence in relation to the social consciousness is relative to the next thought process at every moment. Social existence is not the past but it is objective in relation to the present and future social consciousness. Relying on real social existence, the social consciousness that exists now and reflects, it is subjective in relation to the existing social existence.

Nature serves as an objective foundation for cultural existence. This includes natural mental processes. There are aspects to a cultural existence that are both objective and subjective. For example, gasoline was objective in the composition of oil, but it becomes a cultural phenomenon due to the activity of the subject. Besides, there are aspects of a cultural existence (e.g., concepts) that are subjective. And there are such historical intangible aspects of cultural existence that they are objective in relation to today’s space and time. For example, the spiritual heritage left by our ancestors serves as the basis for our continued thinking. Or the current spiritual environment in another region is an objective ground for us, Central Asians. In particular, the main and direct spiritual basis of the existing laws on the right to freedom of thought in our country are the views and laws on freedom of thought, which came to us from Europe. Although the real cultural existence serves as the objective ground for its further development as the core of the social existence, this process takes place through human thinking. For example, the transformation of nature into a material culture can only be due to contemplation.

Thus, objectivity and subjectivity in a cultural existence have a harmonious character. It is these same processes that characterize cultural existence that determine the relationship between social existence and consciousness. The new laws on freedom of thought in our republic have already

---

become an element of social existence. Because these events serve as an objective basis for further legal considerations to improve it. Human liberties are historical. Because the real cultural existence that determines a person's next activity is historical, changeable. So it is also historic to improve the laws on freedom of thought.

The research demonstrates the one-sidedness of the principle of historical materialism on the law of social existence determining social consciousness, provides the concept based on dialectical cultural understanding of history, and identifies its methodological significance in studying the criminal law code and freedom of thought.

Different forms of interrelationships in the structure of existence give rise to different forms of space and time. Researchers are also studying the forms of social space and time that represent the structure of social relations. In our view, social space and time as a relatively natural, physical space and time have the following regulatory characteristics, consequently, all metric and topological features, including continuity and continuity depend on the scale of the cultural existence, and the characteristics of the social age depend on the rate of development of the cultural existence. Social space is the location of human society and certain peoples in a particular geographical environment, and social time, firstly, covers the period from the primitive state of human society to the present, secondly, the formation periods, thirdly, the periods of civilization within formations, and fourthly, specific historical years within civilizations.

#### REFERENCES:

1. Engels F. Anti-Duhring. - T.: "Uzbekistan", 1979, page 39.
2. Bruk S.I. The population of the world. – M., 1986, page 36.
3. Chesnokov D. I. Historical materialism. - M., 1965, page 307.
4. Boboev J. The social mind in the developed socialism. – T., 1978, page 6.
5. The Marxist and Leninist theory of the historical process. - M., 1981, page 398.
6. Kosimjonov A.Kh. Public existence and public conscience.// Philosophical and encyclopedic dictionary. – M., 1983, page 448.
7. Fayozov M. Main features of the philosophical analysis of the society.//the texts of the speech on philosophy. –T., 1995, page 295.
8. Karimov I.A. Uzbekistan's own path to independence and development. – T.: "Uzbekistan", 1992, pages 11-15.
9. Karimov I.A. Uzbekistan on the path to deepening the economic reforms. – T.: "Uzbekistan", 1995, page 13.

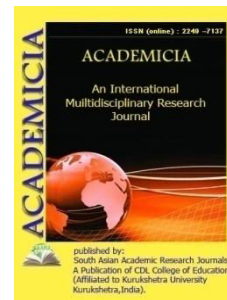
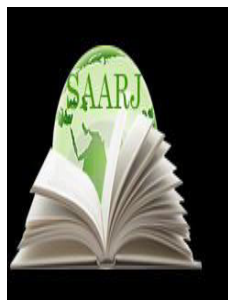

DOI: [10.5958/2249-7137.2021.01896.6](https://doi.org/10.5958/2249-7137.2021.01896.6)

## TYOLOGY OF EXERCISES AND EXPERIMENTAL TRAINING ON TEACHING METHODOLOGICAL FEATURES OF THE RUSSIAN LANGUAGE

**Khamraeva Gulshod Arslanovna\***

\*Ph.D., Senior Lecturer,  
Department of Modern Russian Language,  
UzSWLU, UZBEKISTAN

### ABSTRACT

*This scientific article is devoted to the method of teaching the stylistic properties of the Russian dialects of the students of the Uzbek groups. Analysis of the linguistic and methodological literature in the aspect of the problem under study, the results of the ascertaining section confirmed the need to develop a special system of exercises for teaching the stylistic properties of Russian dialects to students of Uzbek groups. The system of exercises for teaching the stylistic properties of the Russian adverbs of the students of the Uzbek groups was compiled on the basis of the following working hypothesis: the methodology of teaching the stylistics of the Russian adverbs of the students of the Uzbek groups will be more effective and scientifically substantiated if it is built on the basis of taking into account the peculiarities of the stylistic properties of the adverbs of the Russian and Uzbek languages; based on the results of a comparative analysis of the stylistic properties of the dialects of the Russian and Uzbek languages. To test the effectiveness of the developed system of exercises for teaching students of Uzbek groups to the stylistic properties of the adverbs of the Russian language, a training experiment was carried out.*

**KEYWORDS:** *Teaching Method, Teaching Experiment, System Of Exercises, Functional Stylistics, Stylistic Properties Of Adverbs, Functional And Stylistic Vocabulary, Emotionally Expressive Vocabulary.*



## INTRODUCTION

This article considers a series of exercises based on the concept of LV Sherba's three aspects of language phenomena. On creating tasks, to teach the styles and stylistic features of adverb to Uzbek students who do not study Russian as a mother tongue, Djusupov's LV typological exercises based on the concept of Sherba were taken as a basis. They consist of three types:

- formation and development of knowledge of the language system;
- formation and development of knowledge and skills on language material analysis;
- Exercises aimed at the formation and development of speech activities [Djusupov M., 196-199 pg.].

Exercises for the formation and development of knowledge of the language system can be both in the form of questions and in the form of exercises. The main purpose of conducting them is learning and acquiring the language material. Task-questions are gradually becoming complicated, that is, from the simple to complex questions.

The tasks of the formation and development of the knowledge and skills of the analysis of the material have been tested and studied on the basis of the functional methodology and methodological features of the Russian language adverb. These assignments include:

- correctly define the methodological nature of the given grammar category;
- methodical adjustment of adverb designs;
- proper distribution of lexical-methodical units in terms of methodological competence;
- filling a synonymic line of adverbs according to methodological perfection;
- comparison and finding synonyms of Russian and Uzbek languages adverbs;
- translate and compare the adverbs into Uzbek language with the use of subjective priced suffix;
- Making sentences with the various methodological adverb.

Exercises for developing and developing speech activities include: exercises for formulating and developing vocabulary activities; exercises on combating and developing communicative activities (combined exercises), and exercises for the formulation and development of the combination of speaking and communicative skills.

The Uzbek audience has an experimental analysis, pedagogical analysis and its results, which are developed for the teaching of the Russian language adverb teaching methodology. Experimental training was conducted. There were 110 informants from philology and social faculties (except for the specialty "Russian philology"). Of these, 55 students consisted of an experimental group and 55 supervisory teams. All the students who participated in the experimental education were taught at the school in Uzbek.

The training experiment was conducted on the basis of an exercise system designed to teach the teaching process of the Russian language adverb to help Uzbek audiences to eliminate interference in their speech. The methodology developed is different from traditional teaching methods which offered by the authors of current textbooks and manuals. Lexical-grammatical



tasks were put together in the style of work. Interactive methods of teaching were used in the classroom, translation of words and phrases, interactive methods ("brainstorming", cluster) were used to describe new material.

Controlled groups were taught by traditional methodology. In experimental groups - based on the proposed methodology.

The proposed exercise system can be used to master all topics presented in the work program. The topics for the teaching experiment are defined and the exercises that are designed to teach them are particularly effective. In the material "Conveying time interaction in simple sentence" section, fragments of educational experiment are provided. Exercise assignments were made in writing to calculate correct and incorrect answers.

The final phase of the training experiment was conducted in two stages, as the test experiment. At the first stage, training and exercises for formulating and developing knowledge about the language system and the formation of knowledge and skills for analyzing language material (questions and exercises) were given. At the second stage, assignments were given to formulate and develop speech activities.

Computerized test tasks are also provided. The main goal of them is to: control students' knowledge; repetition, strengthening and summarizing the topic.

Results of the qualitative analysis of the teaching experiment showed that: the students of the experimental group acquired a solid knowledge of the methodology of the functional methodology and the Russian language adverb; they are able to determine the style and style of the Russian language adverb; correctly apply methodic neutral and meticulous lexical adverb for understanding the lexical meaning; distinguish functional-methodological and emotional-effective lexicon; they can make conclusions about this situation. All of this testifies to the increase in vocabulary, methodological literacy of students.

Students of the control group are quite knowledgeable about the methodology of functional methodology and the Russian language. Control group students use more neutral lexicon, but they cannot distinguish between grammatical categories in the context. It also indicates the linguistic meaning of the word, the lack of knowledge of the methodology of the Russian language, and the limited vocabulary.

## **CONCLUSION**

The results of the experimental education allow for such conclusions that in the Uzbek groups the functional methodology, in particular the exercise system developed to teach the methodology of the Russian language, is quite effective. The new method of teaching has led to the increase of students' vocabulary, understanding and application of this grammar category in the Russian language as well as the improvement of the learning process.

Comparative description of overall results of experimental and educational experiments

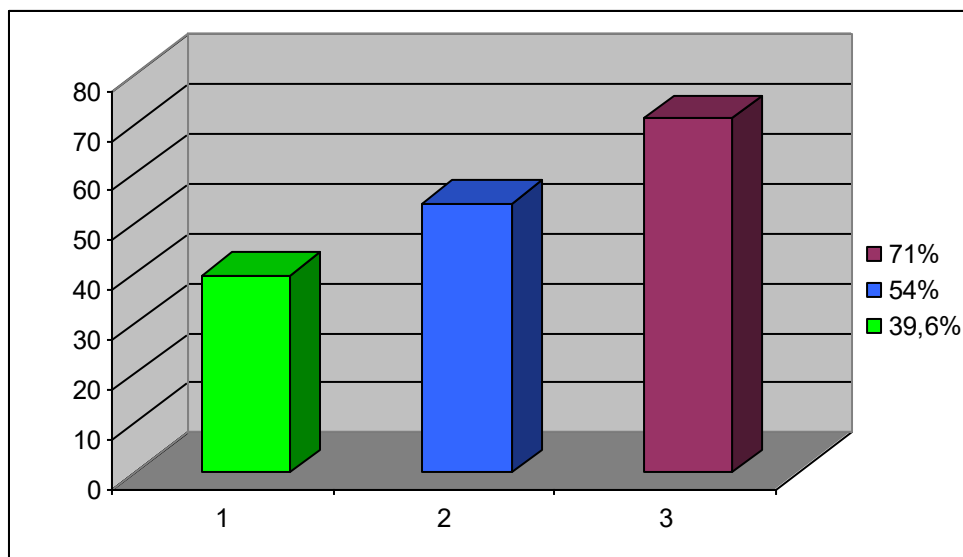

1. Recorded experimental results.
2. Experimental education outcomes (control groups).
3. Experimental education outcomes (experimental groups).

#### REFERENCES

1. Jusupov.M. Sound systems of the Russian and Kazakh languages. Syllable. Interference. Pronunciation training. - T.: Fan, 1991.-- 196-199 p.
2. Khamraeva G.A. Linguodidactic foundations of teaching the stylistic properties of Russian adverbs to students of Uzbek groups: Diss. ... Cand. ped. sciences. - T., 2008.-- 192 p.

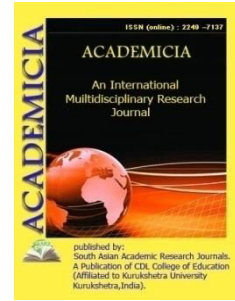
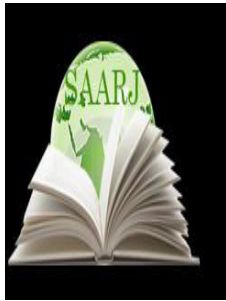

DOI: **10.5958/2249-7137.2021.01897.8**

## COMPONENTS OF GENDER IDENTIFICATION AND DIFFERENTIATION

Zuhrahon Seitova\*; Bahram Utemyratov\*\*

\*PhD philosophical sciences,  
Nukus state institute, Karakalpakstan,  
UZBEKISTAN

\*\*PhD Historical Sciences,  
Nukus state filial UzGUFKS, Karakalpakstan,  
UZBEKISTAN

### ABSTRACT

*Questions related to gender identification and differentiations of different aspects are discussed in this article, including the democratic transformation that takes place in the Republic. The question of the subjectivity and identity of the individual in all of the humanities is raised, distinguishing between the individual and social aspects of identity. In most traditional cultures, there is some kind of similarity of gender ideals. The points of view of researchers such as N. Eisenberg, N. Lennon, English sociologists N. Yuval-Davis and H. Entias, J. Johnson, G. Shulman, and others are taken into account. The author notes that chronologically the first stage of gender socialization is socialization in the family. Mass media today is perhaps the most critical factor influencing the child's socialization, including gender socialization. Gender-role socialization continues at all stages of an individual's development and is implemented in many spheres of his life.*

**KEYWORDS:** *Gender Identification, Differentiation, Human Identity, Gender Behavior, Gender Stereotypes, Masculinity And Femininity.*

### INTRODUCTION

One of the most crucial elements of building the principle of gender equality is achieving total equality between males and females in each sphere of social life. The president of the Republic of Uzbekistan Shavkat Mirziyoyev, on 22 February 2021, mentioning gender equality during the main annual political event – 46<sup>th</sup> session of UN Human Rights Council – among the priorities of

democratic changes in Uzbekistan, noted: "In questions of gender policy we intend to radically increase the role of women in public, political and business life of the country."

It should be noted that lately, Uzbekistan has been taking actions to ensure gender equality, and this was mentioned by Chairperson of the Senate of the Oliy Majlis of Uzbekistan, Chairman of the Gender Equality Commission Tanzila Narbayeva during her speech on the United Nations 75<sup>th</sup> General Assembly devoted to the 25th anniversary of the Fourth World Conference on Women Rights. She stressed that the Uzbek authorities had adopted about 20 legal acts to protect and expand women's rights, developed a Strategy for Achieving Gender Equality until 2030, and introduced a particular procedure under which all new laws are analyzed from a gender perspective.

The problem of subjectivity and the individual's identity is becoming one of the central issues in all of the human sciences. Gender, along with ethnicity and class affiliation, creates an "identity syndrome," which is one of the leading, most stable criteria determining the formation of the individual's identity. According to English sociologists N. Yuval-Davis and H. Entias, such components of identification such as gender, class, and race should be considered only in close correlation<sup>1</sup>.

The primary documents reflecting the international community's obligations to create conditions for the development of gender equality are the Convention on eliminating all forms of discrimination against women<sup>2</sup> of 1979 and the Convention on the child's rights<sup>3</sup> 1989. These essential documents show the transition from mere proclamation to identifying the issues that should be addressed to the adoption of measures necessary to implement these rights. The Platform of Action, adopted at the Fourth World Conference on Women in 1995<sup>4</sup>, identified a set of measures to implement the Convention on eliminating all forms of discrimination against women. It recognizes that discrimination against women and girls in allocating economic and social rights, as a direct violation of economic, social, political, and cultural human rights.

In modern science, identification is understood as the emotional and cognitive process of the subject uniting himself with another individual or group and the inclusion into their world and adoption as his norms of values and patterns<sup>5</sup>. The concept of identity contains the idea of the individual and social nature of a human being. The distinction between the individual and social aspects of identity expresses the duality of human nature - females and males are, on the one hand, unique individuals. On the other hand, they are members of their gender groups, which significantly influence their individuality formation. A person's identity is not a once-and-for-all entity; it can change throughout a person's life as their knowledge of himself changes in interaction with others and modifications in their social roles.

In today's society, there are rather rigidly defined gender-approved behavior, prescribing the manifestation of specific personal characteristics of men and women. These norms are not universal, and their relativity was first illustrated by ethnographers who studied different cultures and noticed the great variability of gender roles.<sup>6</sup> And yet, most traditional cultures show a certain similarity in gender ideals. The man, as a rule, is generally prescribed to be strong, independent, active, assertive, aggressive, rational, and achievement-oriented. These qualities are commonly referred to as instrumental. A woman is weak, dependent, passive, soft, emotional, conservative, oriented toward others, and this is an escapist behavior pattern. Based on the analysis of masculinity and femininity existing in society, we can talk about the masculinity-

femininity opposition as an opposition of expansiveness-constructivism, on the one hand, and cyclicity- reproductivity, on the other.<sup>7</sup> Until recently, these distinctions were absolutized and considered mutually exclusive, peculiar only to the separate sex, but lately; there has been a tendency to soften these rigid frameworks.<sup>8</sup>

And yet, the gender stereotypes that exist in society have a significant impact on the process of children's socialization, essentially determining its direction. Based on their ideas about masculinity and femininity, parents and other agents of socialization often unconsciously encourage children to manifest these feminine or masculine traits that society is approved.<sup>9</sup> What differences in psychological qualities and abilities can really be seen in boys and girls, and to what extent are they determined by psycho physiological preconditions? Variations in characters and skills within the same sex are no less than between the sexes. There is not much strictly established scientific data on sex differences in the psychological sphere. They include some characteristics of the cognitive, motivational, and ethical spheres. In the early stages of ontogenesis, girls outpace boys in their intellectual development (largely due to the better development of verbal abilities), but at a later stage, differences are smoothed out. Adult men and women, in terms of average indicators of intellectual development, do not differ from each other; their IQ is about the same. At the same time, psychometric studies show that the number of men at both ends of the standard distribution curve, based on the measurement of the coefficient of intelligence, is markedly higher than the number of women. This suggests that the distribution of intelligence in the population of men is uneven, with more individuals, with shallow indicators of intellectual development and highly gifted, with maximum IQ scores. Women tend to have better verbal skills, while men are better at math and visual-spatial skills.<sup>10</sup> The study of the motivational sphere showed that in men, the leading type of motivation is the orientation to success, and in women, the motive of avoiding failure dominates. In addition, men have significantly higher reasons for competition. Numerous studies of these differences indicate that the leading factors in their formation are not biological and socio-cultural.<sup>11</sup> The differences in the sphere of morality are also socio-culturally determined since, during the socialization of children of different genders, emphasis is placed on different moral and ethical principles: the principle of individualization for boys and the principle of cooperation and collaboration for girls.<sup>12</sup> Men in their judgments emphasize abstract notions of duty, justice, and personal freedom; women, in general, hold broader views and focus on helping other people. Women predominantly describe themselves in terms of relationships and evaluate their own achievements in terms of usefulness to others, while men are focused on personal achievements, considering them the only form of success.<sup>13</sup>

It is commonly believed that women and men significantly differ in the emotional sphere. Women are better at expressing emotions and are more receptive to the feelings and moods of others people because their empathy index is higher. This is also confirmed by data from various studies.<sup>14</sup> However, N. Eisenberg and N. Lennon found that the less obvious it was that the test aimed at measuring empathy, the less it revealed gender differences.<sup>15</sup> It can be assumed that men prefer not to show their responsiveness and emotionality for fear of deviating from common gender stereotypes. In addition, it is necessary to take into account the peculiarities of male socialization, in the course of which men's empathic responsiveness is suppressed and, as a result, men are inexperienced in this area, and they often do not know how to respond to another person's emotional discomfort. J. Johnson and G. Shulman found that women are more likely to

express feelings toward others. At the same time, men tend to express egocentric feelings, which also correspond to the direction of their gender socialization. Differences in the level of aggression are among the most reliable gender differences. But here, also, we meet with different evaluations of this phenomenon by researchers. E. McCoby and C. Jacklin concluded that aggression is the only type of social behavior for which there is scientific evidence that suggests clear gender differences.<sup>16</sup> At the same time, Eagley and Steffen believe that in adults, these differences are quite small. The fact is that the vast majority of research on aggression is concerned only with its physical manifestations; it does not take into account other types of aggression. As children, girls prefer to express aggression in indirect ways, while boys more often choose to express it openly. As they get older, men also increasingly prefer verbal aggression and indirect ways of expressing it because the norms of modern civilization consider physical aggression as unacceptable. At the same time, of course, physical aggression is much more common among men.

The common stereotype that women are more conformist has also not been convincingly confirmed by the studies. 82% of studies comparing this index in men and women and 74% of studies purposely looking for differences in suggestibility between the sexes were not found any differences. A. Eagley and W. Wood conducted experiments to prove that women are not naturally more compliant. The demonstration of this quality is influenced by their social status and upbringing in which they are required to be more obedient than boys. Men are less conformist because following social stereotypes requires them to be independent in their judgments and actions. Boys, being children, are encouraged to assert their opinions and give them more autonomy. Thus, the observed difference in the manifestation of conformity is a consequence of different upbringing conditions rather than an inherently deterministic peculiarity.

So, research on gender differences in recent decades has been shattering many established gender stereotypes. But, as we've already mentioned, despite the insignificance of these differences, boys and girls inherently have unequal conditions in the process of socialization. From the very beginning, the social world turns to the boy and girl from the very on different sides, and extremely different demands and expectations are placed on them. In national science, the peculiarities of gender socialization, including the effect of sexism that creates external and internal barriers to self-realization, have been insufficiently studied. Sexism means as attitudes or actions that belittle, exclude, undervalue and stereotype people on the basis of their gender.<sup>17</sup> Traditional patriarchal views on the roles of men and women in society accompany the entire process of a child's socialization. Chronologically, the first stage of gender socialization is socialization in the family. Cultural stereotypes and their own experience tell parents what kind of boy and what kind of girl they should bring up, and they strive to raise their children according to these models.<sup>18</sup> As discussed above, even in the first months of life, parents interact with their children differently depending on their gender. This is manifested in such little realized parameters such as the intensity of bodily contact, the tone addressed to and etc.; the video monitoring shows that mothers talk more and make more bodily contact with the female infants, while with male infants, they conduct games that encourages the physical growth. The primary gender identity is formed by the age of two when children become aware of their own gender and distinguish others by this characteristic. By age seven, and sometimes earlier, the child begins to understand the immutability of gender (reaches gender constancy). From a very



early age, parents encourage children to follow gender norms and censure and sometimes punish for deviations from them. Initially, children's gendered behavior is controlled from the outside, and then there is the development of a mechanism that controls a person's adherence to gender norms. Gender-role socialization continues throughout different stages of an individual's development and is realized in many spheres of his or her life.

Parents choose toys for their children that they consider "appropriate" for their gender. Subsequently, the child himself is given prefers toys that stereotypically correspond to his or her gender. Since early childhoods playing games is very important for a child's development and is his leading activity, the analysis of toys allows to clarify their role in gender education. Toys for boys are oriented towards active and moving play. Toys encourage inventive and active exploration of the world around them (constructors, guns, cars, sports equipment), while toys for girls are designed for quieter activities, often focused on household chores and preparation for the future role of a mother (dolls, sets of dishes, dolls' houses, etc.). At such an early age, the child is already "informed" about preferred activities according to his or her gender belonging. Children's books are another important source of learning gender roles, as children also learn about the world through books and absorb traditional notions of masculinity and femininity, including learning how children of their age and gender should behave. In fairy tales and children's books, men almost always are presented as heroes and discoverers, before whom the whole world is open, and a woman is the lady and keeper of the house.

Today, the mass media turn out to be perhaps the most critical factor influencing a child's socialization, including gender socialization. A. Bandura suggested that television is capable of competing with parents and teachers as a source of role models to follow. With the active entry of advertising into our lives, this influence has intensified. Advertising permeates all areas of social life, influencing many social institutions and individual behavior. Advertising, in a rather aggressive form, imposes certain gender ideals and behavioral clichés by emphasizing gender differences. In advertising, men are identified not only on the basis of gender, but their behavior also serves as an expression of social, professional status, and individuality, the range of their occupations in commercials is three times wider. Women in advertising have more emphasis on their gender and the role of the housewife.<sup>19</sup> Gender roles continue to be reinforced in the games of primary school students, as well as in the interaction of children with older groups. Since the motivation "to be like everyone else" is strong enough to form friendships and recognition of the individual in the group, compliance with the expectations of the group contributes to the consolidation of gender stereotypes and further formation of gender identity. It is believed that at this age, boys should demonstrate masculinity by showing strength, agility, and fighting spirit in sporting events that become the basis of play adolescents. Courage and endurance are encouraged, while weakness and passivity are condemned. The boys' games are aimed at identifying leaders and are competitive in nature. In their games, the girls, on the other hand, primarily reproduce models of different relationships between people and imitate situations of interaction: daughter-mothers, seller-buyer, doctor-patient, teacher-student. The famous Czech psychologist M. Chernoushek gives evidence of the existence of differences in the organization and structuring of space in children's games of boys and girls. Boys tend to capture and subordinate external space, and girls are more concerned with inner space. Later on, men are inclined to conquest, master the world around them; they have a strong spirit of competition;

women are more inclined to organize and beautify the environment and are more inclined to establish and maintain social contacts.<sup>20</sup>

In accordance with these models of behavior, the upbringing process for boys and girls is carried out and at school, where the child spends a lot of time and is constantly confronted with stereotypes gender roles. Girls are not encouraged to be active, curious, risk-taking, independent - which are the very qualities that are the basis for optimal development of abilities. In general, boys get more attention at school: they are praised or scolded, their questions are answered more fully, and they are encouraged to be active and curious.

Teachers attributed girls' academic failure more often to a lack of aptitude, while boys' failures are attributed to a lack of diligence and concentration.<sup>21</sup> Agree that these are fundamentally different approaches: girls here are denied to have the potential for success (after all, it is much harder to overcome lack of abilities than laziness and inattention). Adults are more tolerant of boys' norm-breaking, aggression, and unauthorized activity, adults thereby stimulating their activity. On the other hand, girls are under a lot of pressure to be obedient and follow the rules, regulations, and traditions. because obedience is valued as one of the traditional females' "virtues." Boys' lack of autonomy is condemned, while girls are not only allowed to be dependent on others but are even encouraged to do so. As a result, boys learn the principle that one should only rely on one's own merits, while girls' self-esteem depends on the other's.<sup>22</sup> Some researchers assess the process of gender socialization slightly differently and believe that it has its specifics.

It has been noted that boys are in a less favorable position than girls in terms of gender identity formation. Boys must "change their original female identity (with their mother) into a male identity, modeled after significant adult males and cultural standards of masculinity."<sup>23</sup> In Uzbekistan, this process is complicated by the fact that most of the people that the child encounters are females (kindergarten babysitters, doctors, and teachers). And Kagan also writes about the phenomenon of the psychological feminization of men and the masculinization of women. "The rigidity of requirements for the masculinity of boys has become predominantly declarative. The boy, in the course of upbringing, passes from one female hand to another; no matter how much the boy heard from women what a real man should be, he is brought up, above all, as a "handy for women." The rigidity of the demands of masculinity grows in parallel with social barriers to masculinization, creating an emotional and cognitive dissonance that contributes to either gender confusion or exaggerated masculine gender orientation. In this regard, the demands on girls' femininity are progressively diminished, and to the range of their gender-role orientations masculinized stereotypes of adult women are added".<sup>24</sup>

So, we have considered the process of assimilation of gender roles and the formation of gender identity in its main manifestations. It should be taken into account that religious, social, economic, ethnic differences can introduce variations. Gender identity is formed in childhood and strengthened in adolescence but may change later in life. Modern research provides compelling evidence that many gender differences previously were biologically determined, in fact, caused by social norms. The biological, psychological, and social factors influencing the formation of gender identity are so closely intertwined that it is almost impossible to distinguish between them to determine where one factor ends and the effect of the other begins.

Modern human science is increasingly inclined to believe that differences in the behavior of women and men are shaped primarily by their social learning. It should be remembered that the cultural components of gender can vary. Still, they cannot be considered without relating them to gender: "no matter how much a man behaves like a woman, no matter how feminine his behavior seems, the actions of that person and the attitude of society toward it will not make him less of a man, much less turn him into a woman."<sup>25</sup> And yet, the gender norms existing in society have a great influence on the process of children's socialization, largely determining to a large extent its orientation. The process of raising boys and girls is carried out in accordance with traditional gender stereotypes, and the first manifestations of differential socialization can be observed even before a child is born. Consciously or unconsciously, parents encourage their children to follow a pattern of behavior appropriate to the boys and girls have very different expectations and demands of them, and, as a result, they develop different personal qualities, skills, and abilities. "Gender differences are not as great as popular stereotypes lead us to believe."<sup>26</sup> A person living in a culture, in this case, it's about psychosocial culture, relates his behavior to the stereotypes inherent in that particular culture. He can strive to conform to them as much as possible or, on the contrary, deny them, but in any case, they serve as a reference point for him.

#### REFERENCES:

1. Alyoshina Y.E., Volovich A.S. Problems of assimilation of roles of a man and a woman // *Voprosy psichologii*, 1991, № 4.
2. Andreeva G.M. *Social psychology*. - M.: Aspect Press, 1999. -376 c.
3. Berne Sh. *Gender Psychology*.- S.-Petersburg: Prime-Eurosnack, 2001.-320 p.
4. Guseinova L.A. Value orientations: gender aspect.
5. Gilligan K. *With other Voice / Ethical Thought* 1991. - M.: Thought, 1992.
6. *Women and Men*. Uzbekistan.statssbornik.-T.2002.-120p.
7. Zdravomyslova E.A., Temkina A.A. *Social construction of gender as a feminist theory / Woman. Gender. Culture*. -M.: 1999.
8. *Sociology of Gender Relations and Gender Approach in Sociology // Sociological Studies*, 2000, №11.
9. Zdravomyslova-Stoyunina O.M. *Society through the Prism of Gender Representations / Woman. Gender. Culture*. M.-.1999.
10. Kalabikhina I. *Social gender and the problems of the population*. - Moscow: Manager,1995. – 149p.
11. *The gender approach in the system of psychological education / Gender Studies: Feminist Methodology in the Social Sciences. Materials of the 2nd International Summer School on Gender Studies (Foros - 1998) / Ed. by I. Zhrebkina*. - Kharkov: KCGI, 1998. – 356p.
12. Kon I.S. *The Child and Society (Historical and Ethnographic Perspective)/ USSR Academy of Sciences, N.N. Miklukhov Institute*. In: *Miklukho-Maklai*. - Moscow: Nauka, 1988.
13. Myers D. *Social psychology*. - Saint-Petersburg: Peter Com, 1998. -688p.
14. Mead M. *Culture and the World of Childhood. Selected works*. - M.: 1988. -429 p.

15. Popova L.V., Problems of Self-realization of Gifted Women // Voprosy psichologii, 1996, № 2.
16. The situation of children in the world.1999.educationn.UN, UNICEF: Children's Fund, 1999-140p.
17. Smelser N.J. Sociology. - Moscow: Phoenix, 1994. – 687p.
18. Khasan B.I., Tyumeneva Y.A. Features of assimilation of social norms by children of different genders // Psychological issues, 1997, No. 3.
19. Hyll L., Ziegler D. Theories of personality (main provisions of research and notes). - S.-Petersburg: Peter Com, 1998. - 608 p.
20. Cherawshek M.The psychology of the environment.- M . M.: Thought, 1989.
21. Convention on the Elimination of All Forms of Discrimination Against Women // UN Treaty Series. T. 1. - New York. Geneva. -1994. - 172 p.
22. United Nations Convention on the Rights of the Child. - MOSCOW: INFRA, 2002.- 24p.
23. On the Implementation of Decisions of the Beijing Platform for Action on the Status of Women in Respect of Women's Rights // Information and Publicist journal for young people - Moscow: Women's Association 'Femina' - 2001 - Issue YII - P. 21 - 56.



**ACADEMICIA**  
**An International  
 Multidisciplinary  
 Research Journal**  
 (Double Blind Refereed & Peer Reviewed Journal)

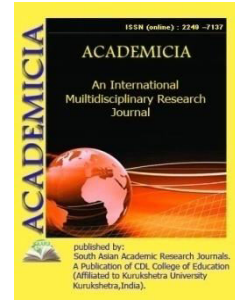

**DOI: 10.5958/2249-7137.2021.01898.X**

## MODERN TRANSFORMATION OF THE ESSENCE OF THE COMPETITIVENESS OF INDUSTRIAL ENTERPRISES

**Tashmuxeimedova Karima Samatovna\***

\*Tashkent Institute of Architecture and Civil Engineering,  
 UZBEKISTAN

### ABSTRACT

*This article analyzes the modern transformation of the essence of competitiveness of industrial enterprises and its importance. The article establishes that the development of an industrial enterprise in the conditions of the information economy requires an assessment of the competitiveness of the enterprise. In the case where the absolute assessment of the ability of an industrial enterprise to introduce new technologies is equal to one, this enterprise can be considered as fully adapted to the use of modern tools and technologies provided by the information economy. The country in this case development and introduction of technologies and, most importantly, industrial enterprises are starting to develop global strategies abroad makes large-scale investments. At the same time, competitiveness is the ability to compete with others in real market conditions. Competitiveness is determined by the results of marketing research.*

**KEYWORDS:** *Modern Transformation, Uzbek Economy, Enterprises, Competitiveness Of Industrial Enterprises,*

### INTRODUCTION

The competitive advantage of the Uzbek economy lies in innovation can rely on the industrial enterprises of the republic in the coming decades is a promising area of development and it is the national economy includes the internal potential of competitiveness. The country in this case development and introduction of technologies and, most importantly, industrial enterprises are starting to develop global strategies abroad makes large-scale investments. In the integrated assessment of competitive advantage: systemic, complex and normative approaches are considered appropriate. In the position of a systematic approach to the integrated assessment of competitive advantage a separate assessment of the internal structure and external factors of the system is required.



In all spheres of social development in the Republic of Uzbekistan, the most first of all, further deepening and liberalization of reforms in the economic sphere A clear program has been developed. This is the main purpose of the program the goal is to implement democratic and market reforms in Uzbekistan, the world strong for broad integration into the community and sustainable progress to lay the groundwork. All sectors of the economy of the republic from the demands of a market economy for the benefit of businesses require production or service. Of the Republic important factors in achieving economic and financial stability, production increase in volume, reduce the devaluation of money, increase the volume of exports, etc. activities in the country while ensuring similar macroeconomic growth as business entities of every enterprise, firm, companies operating requires development [1].

There are various theoretical concepts and practical approaches to competition, competitiveness and competitive advantage. A comparative analysis of the definitions of these concepts by foreign and domestic scholars can be defined as follows: It is a competition between market participants in order to gain their trust and to have the intended money resources". Competitiveness is the ability to compete with similar competitors, to maintain equality in competition, and in some cases to gain an advantage. Competitive advantage is the difference between the price and quality of a market entity with competitors and their suitability for buyers and consumers. There is a link between competition and competitiveness, and one comes from the other. Competition encourages companies to produce competitive goods and services.

Competitiveness is an object property that characterizes the level of satisfaction of a specific demand for the best similar objects available in the market.

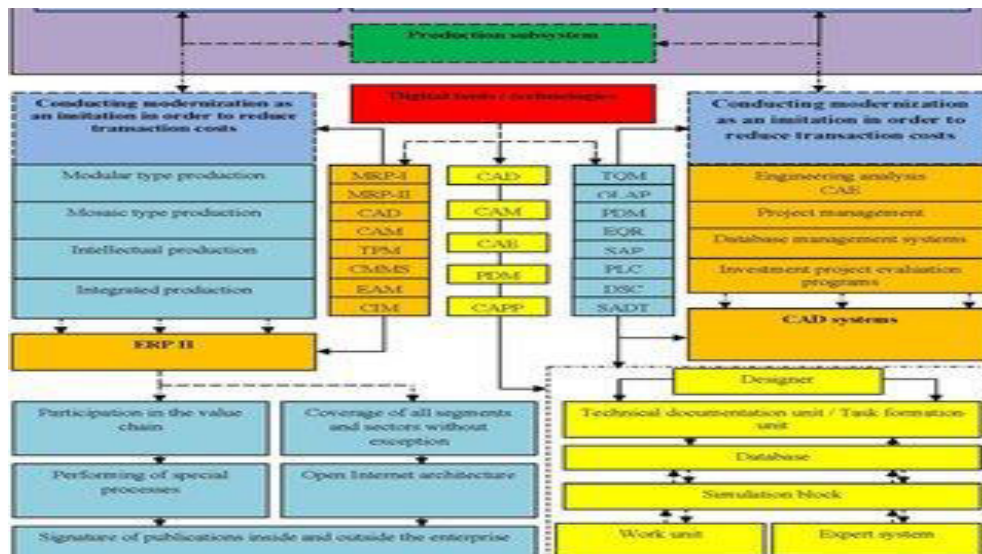

At the same time, competitiveness is the ability to compete with others in real market conditions. Competitiveness is determined by the results of marketing research. It is a description of a product that differs from a competitor's product in terms of both the degree of its suitability for a particular social need and the cost of meeting it. In the practice of Uzbekistan, the concept of "product quality", which has the same meaning as the concept of "product competitiveness", is more commonly used in relation to goods, because product quality is understood as a feature of low cost and optimal customer satisfaction. The competitiveness of a product is determined by its superiority over other manufacturers of the same type in terms of quality and price.



Competitiveness of firms is related to the ability to produce and supply the same or substitute products of the same or substitute to similar, competing enterprises in terms of quality and lower prices in terms of consumption characteristics.

It is proposed to build a mechanism for assessing the competitiveness of an industrial enterprise in the information economy based on three models. The first one is a model of comparative evaluation of the competitiveness of an industrial enterprise, which makes it possible to compare the company with competitors or with world leaders. The second one is a model for assessing the capacity of an industrial enterprise to introduce new technologies that are constantly emerging in the information economy. The third component is the integrated quantitative assessment of competitiveness, which allows comparing such complex and multi-element characteristics of the enterprise as the competitiveness of different enterprises. A model for comparative assessment of the competitiveness of an industrial enterprise provides an opportunity to calculate indicators that characterize the competitive advantages or disadvantages of an industrial enterprise in the aspect of functioning in the information economy and compare them with other enterprises, competitors in the industry and the region where the enterprises operate or enterprises that are world leaders this area.

The next component of the mechanism for assessing the competitiveness of an industrial enterprise in the information economy is a model for assessing the ability of an industrial enterprise to introduce new technologies that are constantly emerging in the information economy. The research on domestic and world successful machine-building enterprises makes it possible to conclude that the ability to implement new technologies depends on many factors, some of which may be considered key. Among them:

- a) Availability of highly skilled personnel capable of adapting and implementing the latest technologies,
- b) Sufficient qualification of the majority of personnel in the field of information technology use,
- c) Availability of financial resources for implementation or the ability to attract them from the outside.

Calculation of the absolute assessment of the ability of the industrial enterprise to introduce new technologies  $A_v$  is proposed to be carried out by drawing up all the received marks. The evaluation of these factors is suggested by analyzing relevant indicators.

In the case where the absolute assessment of the ability of an industrial enterprise to introduce new technologies is equal to one, this enterprise can be considered as fully adapted to the use of modern tools and technologies provided by the information economy. The last element of the modeling mechanism for assessing the competitiveness of an industrial enterprise in the information economy is the integrated quantitative assessment of competitiveness. It is suggested, when calculating the integrated quantification, to use the indicators of the previous two models, namely: the degree of automation of production; the degree of informatization of business processes; the degree of representation of the enterprise in the information space; an absolute assessment of the ability to introduce new technologies [2].

These four indicators are displayed in a four-dimensional space and form the corresponding figure. Also in this space is a figure that consists of estimates of these indicators in the industry

average. The integrated quantitative score in the result is the ratio of volumes of these two figures (Fig. 2).

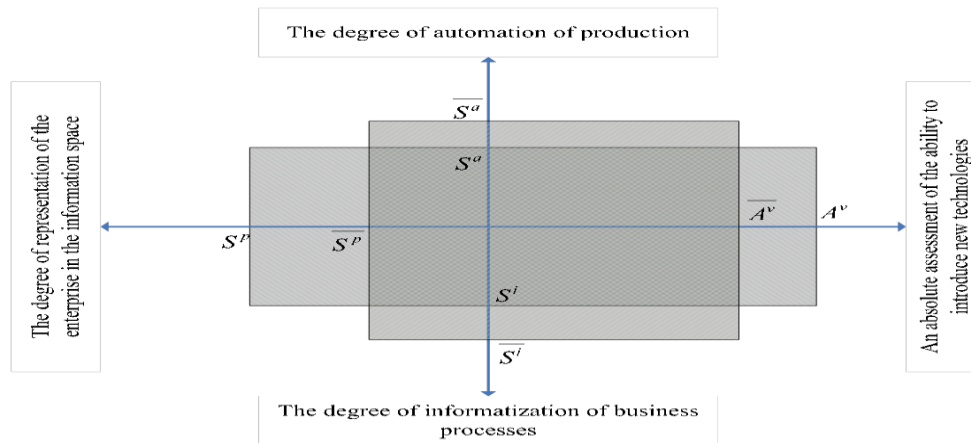

In addition to the model support, the mechanism for evaluating the competitiveness of an industrial enterprise in the information economy includes information support, which consists of an information system for monitoring the environment and an information system for analyzing the competitiveness of the enterprise. The first information system provides the collection and aggregation of data, which necessary for the assessment of competitiveness. The second provides the presentation of the results of the assessment of competitiveness in the form convenient for owners and managers, and also provides opportunities for analyzing the sensitivity of the components of competitiveness, their response to the change of individual factors. Thus, a mechanism for assessing the competitiveness of an industrial enterprise in the information economy has been developed, which implies a set of interacting elements and constitutes a holistic tool for collecting and processing information aimed at obtaining estimates of the competitiveness of an industrial enterprise in its operation in the conditions of the information economy. This mechanism provides the control system of the industrial enterprise on the basis of developing measures for its development in the conditions of the information economy, taking into account the existing and potential competitiveness of the enterprise.

## REFERENCES:

1. <http://tsue.uz/>
2. N.S. Nosova Competitive strategy of the company or marketing methods of competitive struggle / M.: Publishing and trading corporation "Dashkov and KO" Saratov 2010.
3. Mazilkina E.I., Panichkina T.G. Competitiveness management. Study guide - "Omega-L", 2009
4. Aumann, R. J., & Heifetz, A. (2002). Chapter 43 Incomplete information. Handbook of Game Theory with Economic Applications (T. 3, s. 1665–1686). Elsevier. [https://doi.org/10.1016/S1574-0005\(02\)03006-0](https://doi.org/10.1016/S1574-0005(02)03006-0)
5. Borodin, I. F. (2006). Avtomatizatsiyatehnologicheskikhprotsessovisistemyiavtomaticheskogoupravleniya [Automation of technological processes and automatic control systems]. Moscow, Kolos,

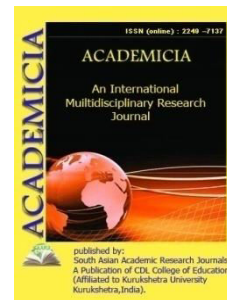

DOI: **10.5958/2249-7137.2021.01899.1**

## MEANS OF GOVERNMENT REGULATION OF INVESTMENT AND CONSTRUCTION ACTIVITIES

**Axmedova Sanobar Ikrom qizi\***

\*1st year Basic Doctoral Student, Specialty "Industrial Economics",  
Faculty of Construction Management,  
Department of Economics and Real Estate Management,  
Tashkent Institute of Architecture and Civil engineering,  
UZBEKISTAN

### ABSTRACT

*The article discusses the mechanisms of state regulation of investment and construction activities in Uzbekistan. The state of financing of capital investments is analyzed. Measures are being taken to improve the mechanisms of state regulation of investment and innovation processes in Uzbekistan. This, in our view, can be achieved by strengthening the regulatory function of taxes levied on legal entities and individuals in the economy, as well as foreign investors. Indeed, the President is directly involved in foreign investment unconditional implementation of projects, comprehensive assistance to foreign investors He stressed that giving should be the most important task of the government. This is necessary for implementation of particular actions and purposeful policy of the government and for business structures as a support of the state to business entities in search of the entry of domestic high-tech and high-intellectual products into the world market.*

**KEYWORDS:** *Investment, Construction Activities, State, Mechanism, National Economy*

### INTRODUCTION

The investment and construction activities is considered as a very important component in the development process of any state, which is still not able to effectively develop independently without effective regulatory mechanisms, therefore, a significant role is played by public levers, which should provide enough opportunities for the implementation of innovative and investment processes.

Today, the investment and construction activities of the country has insufficient investing of the national economy, which amplifies the decline in production and results in reduced investment capacity of business entities and the state. Only a scientifically grounded and effective investment policy of the state may improve such situation in Uzbekistan.

The Republic of Uzbekistan on effective management of investment projects President Sh.M. "We are trying to invest in our economy," Mirziyoyev said Thorough investment projects for investors by regions and sectors If we can shape it, we can achieve a positive result in this regard,"he said passed. Indeed, the President is directly involved in foreign investment unconditional implementation of projects, comprehensive assistance to foreign investors He stressed that giving should be the most important task of the government. Postpone the disbursement of the bulk of the investment to the last months of the year put an end to the practice and do so in all sectors and regions in the first half at least 35 percent, and 70 percent in nine months [1].

Mechanisms for coordinating investment activities in Uzbekistan should be aimed primarily at stimulating the growth of savings at all stages of management and reducing consumption. This, in our view, can be achieved by strengthening the regulatory function of taxes levied on legal entities and individuals in the economy, as well as foreign investors. Strengthening the incentive functions of taxes within the system of investment promotion will lead to expanding the role of market mechanisms in financing investment. In order to expand the inflow of foreign direct investment, it would be expedient to exempt foreign investors from all forms of customs duties, taxes and levies until they have mastered the production capacity. It would be preferable to apply the preferential taxation procedure for each foreign direct investment after they have fully mastered the production capacity.

The main task of state regulation of investment activities in building a diversified economy in the host country is to coordinate their optimal ratios, create equal legal conditions and guarantees for their implementation.

Typically, the coordination of investment activities is aimed at creating favorable conditions in its key areas, primarily to meet social needs through social development, technical improvement of production, the introduction of innovations and inventions. Each state coordinates investment activities for the following purposes: implementation of the state's economic policy in the process of transition to a market economy; implementation of the state science and technology policy and, on this basis, strengthening the economic strata and access to world markets. Pursuing the social policy of the country.

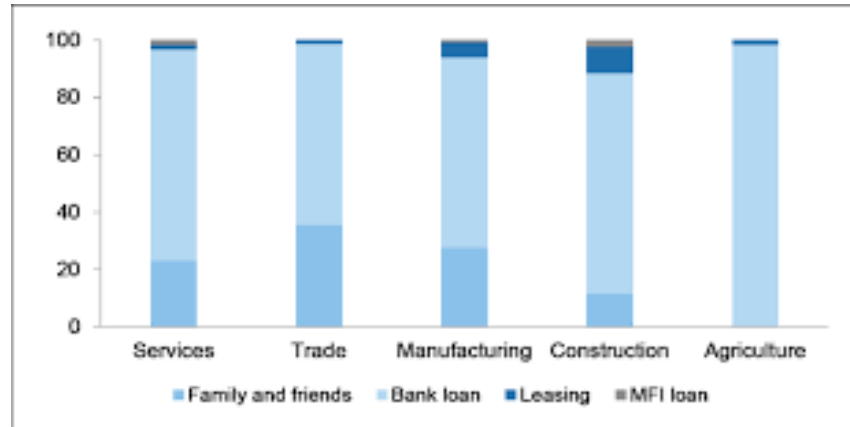

Funding of significant research investment and innovative processes should be carried out by the state in order to determine the priority directions of scientific and technological and innovative activity. This is necessary for implementation of particular actions and purposeful policy of the government and for business structures as a support of the state to business entities in search of the entry of domestic high-tech and high-intellectual products into the world market. For this purpose it is necessary to use the maximum capacity of the domestic scientific and technical potential.

Management of investment activity by the state is carried out on the basis of a number of measures, their implementation. These measures include:

- Simplification of the tax system, ie the classification of tax subjects, objects and rates and the provision of tax benefits.
- Implement depreciation policies, including accelerated depreciation policies and granting depreciation benefits.
- To support the development of some regions and sectors through subsidies, grants, subventions.
- Development of credit policy, antitrust measures of state norms and standards, privatization of state property and pricing policy.
- Determining the conditions of use of land and other natural resources.
- Inclusion of investment projects in the state program of examination.
- Monitoring and development of a mechanism for investment projects.
- Suspend, restrict or terminate investment activities as necessary or in accordance with the law (fig.1)

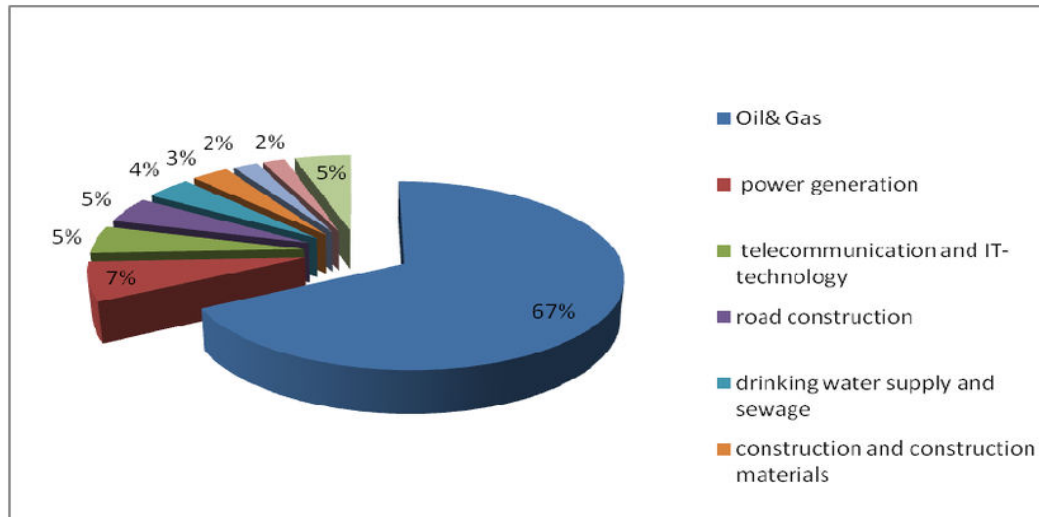

In order to improve the state regulation of the construction industry, to create favorable conditions for attracting investment, to increase the efficiency of the system of professional training, retraining and advanced training of personnel in the construction industry:

1. To establish the order according to which:

a) From December 1, 2018:

Examination of the estimated part of the projects for all construction projects is mandatory, except for facilities whose construction is carried out at the expense of direct investments, including foreign investments;

Acceptance of completed facilities is carried out with the participation of representatives of the construction inspection, cadastral authorities, the customer, the contractor (general contractor), except for the construction of facilities financed from public procurement;

by creating a consortium between contractors and project organizations and assigning joint responsibility for the quality and timeliness of the project to the consortium members by the "fast-track" method (simultaneous design, procurement and construction) Implementation of projects on the basis of "Engineering Procurement Construction" is allowed;

b) From January 1, 2019:

Recognize certificates and other permits (licenses) issued by the competent authorities, organizations, societies and associations of the Member States of the Organization for Economic Cooperation and Development for the design and construction activities;

the personal responsibility of the relevant governors for the timely and correct allocation of land plots for construction and for the construction and installation work to be carried out without linking to the approved master plan or land layout schemes (in the absence of a master plan);

Expenses incurred as a result of untimely or incorrect allocation of land plots for construction will be reimbursed from the local budgets, followed by recourse from the guilty parties;

national and foreign legal entities, public and international organizations, as well as research institutions specializing in this field, regardless of the form of ownership, have the right to



participate in the revision of national building codes and regulations, as well as the harmonization of foreign construction regulations;

The Ministry of Construction of the Republic of Uzbekistan is the customer of work on development and improvement of national construction norms and rules, as well as adaptation of foreign normative and technical documents on construction and their implementation in practice [2].

### **CONCLUSION**

Investment and innovative activity is an important area in the development of any country and Uzbekistan is not exception. The existing mechanisms of state regulation of investment and innovative processes are not effective and not sufficiently adapted to the current conditions of economy. The main problem in this direction is insufficient public funding of these processes. However, our study demonstrates that our country takes steps to improve the investment climate, they should be more activated and the institutional conditions for the implementation of investment and innovative projects should be improved.

### **REFERENCES:**

1. Vozniuk M. A. (2015), "Perspective directions of improvement of the system of state regulation of innovation and investment processes", Ekonomichnyi forum, vol. 2,
2. On additional measures to improve the state regulation of the construction sector.<https://lex.uz/ru/docs/-4060063>
3. Mamatov. B Investment organization and financing. Tashkent. 2014

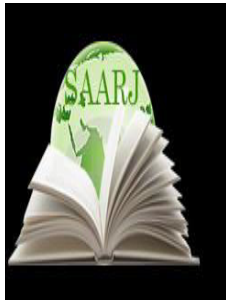

**ACADEMICIA**  
**An International  
 Multidisciplinary  
 Research Journal**  
 (Double Blind Refereed & Peer Reviewed Journal)

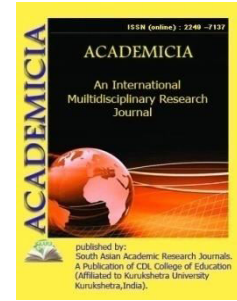

**DOI: 10.5958/2249-7137.2021.01900.5**

**PROBLEMS ARISING IN THE ORGANIZATION OF FINANCIAL  
 MANAGEMENT OF HOUSING STOCK MANAGEMENT COMPANIES  
 AND THEIR SCIENCE-BASED SOLUTIONS**

**Berdiyeva Dilfuza Axatovna\***

\*PhD, Dotsent of "Management in Construction",  
 Faculty of Construction Management,  
 Tashkent Institute of Architecture and Civil Engineering,  
 UZBEKISTAN

**ABSTRACT**

*An organization of technical supervision of the management and maintenance of private housing fund on the basis of public-private partnership has been proposed; The possibility of achieving economic efficiency by using the services of professional managerial enterprises in the management activities of private housing fund has been scientifically justified; Optimized system of training managers through formation of modern management skills and abilities for improvement of housing management quality was proposed; The improvement of the financial mechanism through provision of operational services by the private homeowners' associations has been suggested.*

**KEYWORDS:** *Organization, Housing Management, Service, Companies, Modern Economic.*

**INTRODUCTION**

Innovative process and innovation in modern economic development. The result of the activity is the development of the national economy of any country defining and determining the most competitive in the global market is an important factor. Which enterprise, network, region at the present time or innovative management performance is good in the country's economy as a whole economic growth and development in the same place if established provided.

However, practice shows that innovation in management enterprises, industries, regions and the development of the national economy in general is mainly technical and technological associated with innovation. But management efficiency alone introduction of new equipment and techniques into practice unattainable. In our opinion, modern management methods and the introduction of a system of efficient use of technology is less non - significant.

Update and develop any activity, do it first occurs at the expense of improving methods of increase. So everyone management, which determines the innovative strategy of how to operate an innovative concept aimed at improving the system there is a need to introduce approaches. Management modern to increase efficiency and improve its performance. One of the methods is Lean Production (is the introduction of the concept). Many in the world market successful companies resent their achievements and status with the effectiveness of the approach.

It is known that the national economy of Uzbekistan is more than a hundred different line material production network and sub-networks and represents service areas. One such area is the housing and communal services sector. In scientific parlance, housing the utility is a creator of conveniences for people and their a wide range of housing services, such as homes and water supply for others, water supply, capital repairs construction of settlements through the provision of services ensuring the operation of various engineering infrastructures is an interbranch complex.

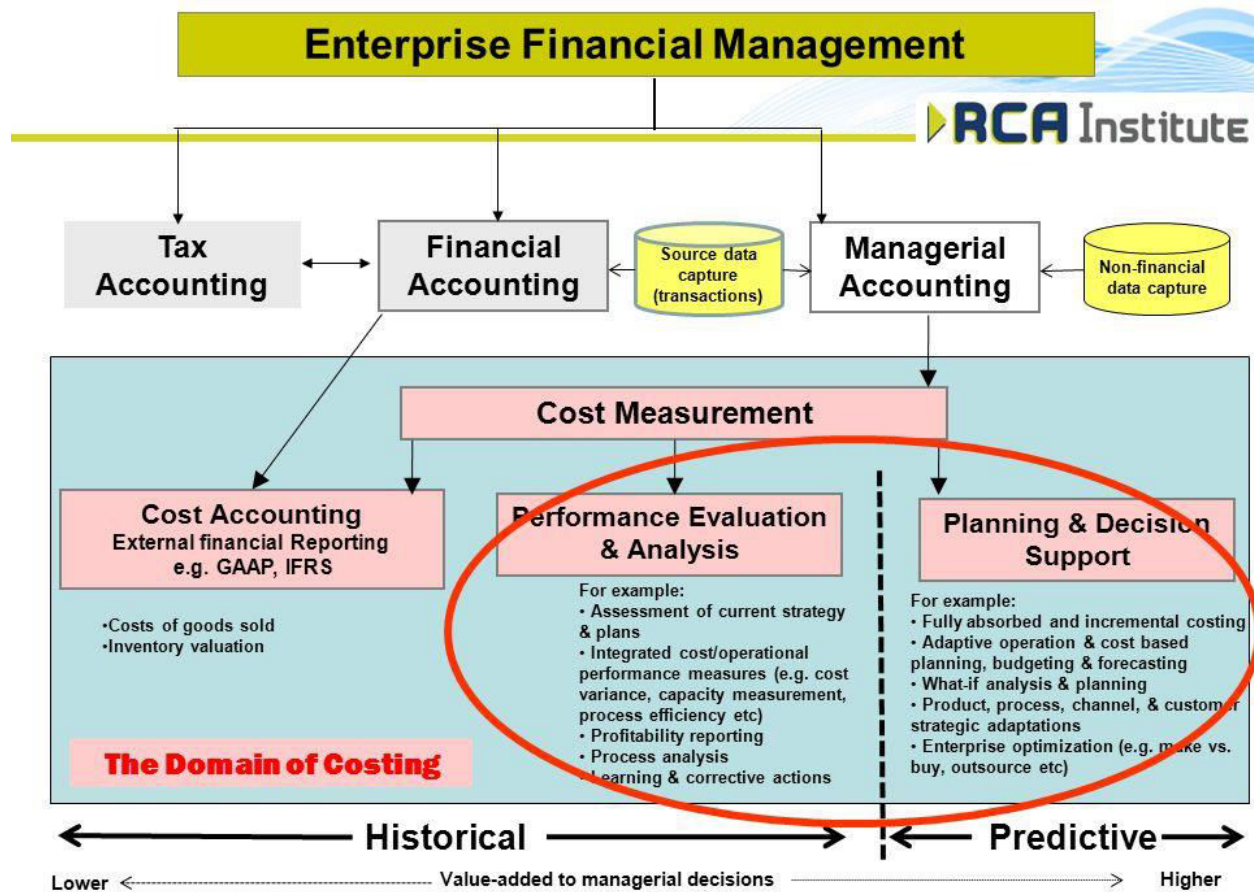

Figure 1.

The state of the housing crisis is the most in the state today has become one of the current problems. This is mainly housing funds obsolescence, formation of tariffs for services, Violations of the obligations of management companies to the public, timely implementation of current and capital repairs, in case of emergency issues such as relocating people from homes. For example, local executive bodies are private housing landlord companies and housing and

communal services does not adequately coordinate its activities. Multi-family housing stock lack of a comprehensive approach to management and use further quality and guaranteed utility services to the population is an obstacle to improvement and is right for homeowners causing objection. Management of public housing in the Republic of Uzbekistan, private housing fund management, multi-apartment house management, company formation, the management of the apartment building, many of which are not organized by the company apartment house management forms are available, these management forms have differences and peculiarities from each other. The improvement in the living conditions of the population is in many respects housing increasing the efficiency of the use of the fund, communal resources from the improvement of delivery quality, new modern resource and from the installation of energy-saving equipment, to the application of new achievements of science depending on the results of the introduction.

Private in Uzbekistan obtained to improve the housing fund management system based on scientific results:

- The proposal of the Republic of Uzbekistan on November 7, 2019 to improve the management system of apartment buildings, to create a free competitive environment in the industry, to conduct a full inventory of housing in order to enable the population to independently choose management companies and to create their passports, including areas adjacent to apartment buildings Taken into account in the Law of the Republic of Uzbekistan No. ZRU-581 "On the management of apartment houses" (reference No. 04 / 03-4686 of the Ministry of Housing and Communal Services of December 9, 2020). As a result, to date, more than 200 management companies have been established on a competitive basis;

-a professional manager in private housing fund management cost-effectiveness through the use of the services of companies proposed to achieve private housing in Tashkent Introduced into the activities of private companies (Tashkent city Private.

To support the activities of professional management companies in reducing administrative costs in homeowners' associations and the introduction of modern information and communication technologies in the management of apartment buildings, the creation of a special electronic platform to ensure openness and transparency in accounting for apartment maintenance costs The proposal was taken into account in the Resolution of the Cabinet of Ministers of the Republic of Uzbekistan dated January 30, 2019 No 67 "On the introduction of modern information and communication technologies in the management system of apartment houses"(Reference No. 04 / 03-4686 dated December 9, 2020 of the Ministry of Housing and Communal Services). As a result, the State Unitary Enterprise "Single Settlement Center" has created an electronic information platform "Obod Uy" to provide settlement services to private homeowners 'associations and professional management organizations, as well as administrative costs incurred by existing private homeowners' associations. its share was reduced to 3.5 percentage points in 2019.

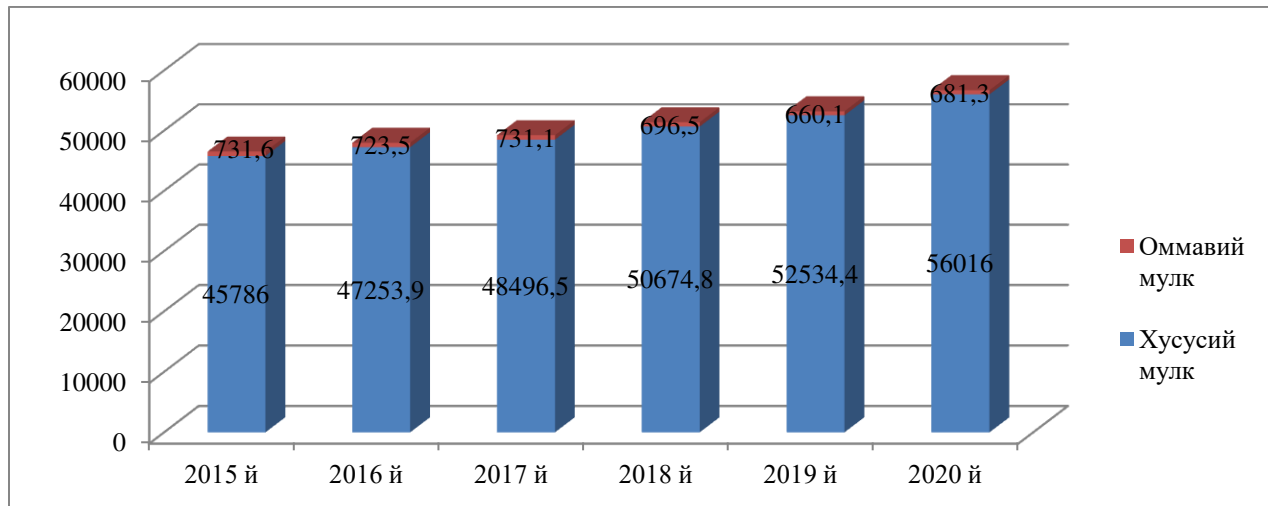

Figure 2. Description of the distribution of housing stock in Tashkent by type of ownership (thousand sq.m.)

From the above data, it can be seen that the area of private property in Tashkent today is higher than that of public property. According to him, in Tashkent alone, we can see that the housing stock in 2020 increased by a total difference of 3502.9 thousand square meters compared to 2019. In 2020, private property will account for 98.8% and public property for 1.2%. Objectives of property management in the housing sector - Owners in the housing sector can own, use and dispose of their property at will and for their purposes, as well as the rules established by the state on the technical and sanitary condition of the housing stock, may set property management objectives by enforcing compliance with norms and standards.

As mentioned above, in the developed countries of the world, the management of the housing stock is considered as a separate type of entrepreneurship. That is, the governing bodies are with the homeowners 'associations provides services and benefits from a contract. According to the author, the tariff for maintenance and repair of the housing stock the normative cost of maintenance services to determine is taken as the starting point. Private to set the tariff amount. The homeowners' association of the housing fund in a particular reporting period determine the income received on the total area used should. The structure of these revenues is the cost of production of services and consists of planned benefits. This includes private housing in the manner prescribed by the owners to cover the costs of the company other sources of revenue to be directed are excluded.

According to the author, the management of the housing stock in Uzbekistan the form is chosen by the owners themselves, the form of management in many respects will depend on the size of the housing stock. Also in our country private housing fund management as in other countries of the world Based on the principle of "single family". Housing management although the shape is chosen by the owners, they are as mentioned above the condition that they choose one of the forms is in our legislation fortified.

Housing management system in Uzbekistan 138 of the Housing Code of the Republic, and in multi-apartment houses Housing Management System "Private Homeowners It is defined in the law "On housing, engineering" equipment, attachment to these houses, land with elements of

landscaping maintenance, servicing and maintenance of plots to repair and create the necessary living conditions for citizens other activities aimed at. Private housing fund management directly housing owners, company, manager (executor director) or by the governing body or to the legislation can be done in a different way accordingly[2].

However, on the part of the researcher on housing fund management international experience is also studied and with the existing system in our country comparative analysis. Some of the developed world in this area. According to the results of the study of the experiences of countries, the majority provision of utilities in countries, including real estate.

As can be seen from Figure 3 below, it can be seen that the majority of the urban population lives in 2-4 bedroom apartments and the demand for manashu part of their houses is high. This indicates that the average population growth rate is high. In 2019, we can see that 5-6-room houses were built in Tashkent only in the country. This shows that the increase in income of the population indicates an increase in their needs. That is, for the population to have a good lifestyle in the housing stock will lead to an increase in the areas that serve them and increase competition between them. This will increase the number of housing service companies and management companies and the need to improve the quality of services they provide. Fake service companies will be replaced by management companies based on the principles of openness and transparency.

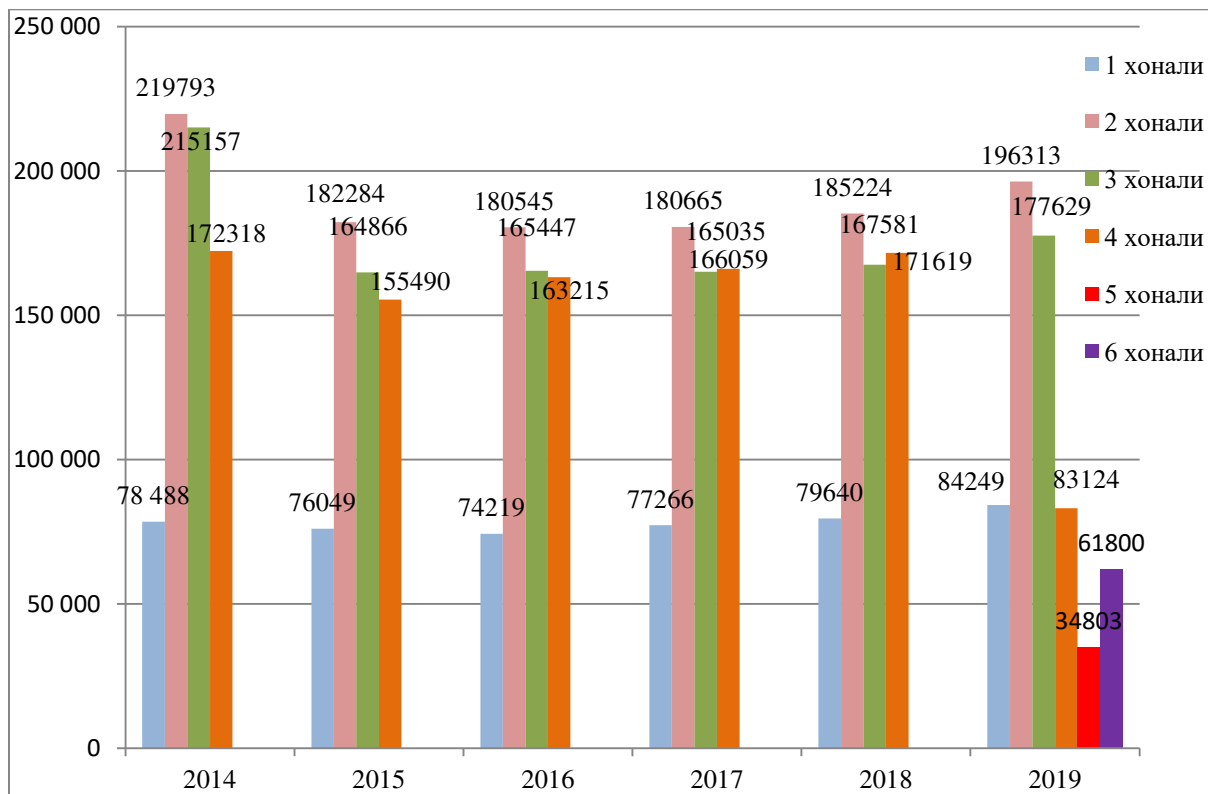

**Figure 3. Dynamics of change in the total number of apartments in Tashkent (by rooms, units)**

Maintenance, repair, maintenance of common property and sanitary condition of the surrounding property (management companies, companies, land plots) identified during the assessment of the



technical and sanitary condition of houses and surrounding areas, mandatory in the preparation of the annual estimate of income and expenses of the management company, also compiles a complete list of works (services) for the improvement of public areas, indicating their scope. If the management company and the company are united by landowners of several (two or more) houses, it depends on the technical condition of the common property of each individual house, the types and scope of work (services) on their maintenance, repair and maintenance. Mandatory fees for each house may be set in different amounts depending on the origin.

**REFERENCES:**

1. Berdiyeva D.A. Improving the efficiency of the mechanism of financial management of housing. Doctor of Philosophy (PhD) dissertation in economics. T., 2021.
2. Berdiyeva D.A. Opportunities to use block chain technology to increase the effectiveness of the housing fund financial management mechanism // "South Asian Journal of Marketing Research & Management (SAJMMR)". ISSN: 2249-877X Vol. 11, Issue 3, March 2021, Impact Factor: SJIF 2021= 7.642. India.
3. Berdiyeva D.A., Sanakulova B.R. "Increasing The Effectiveness Of The Housing Finance Management Mechanism" // International Journal of Advanced Science and Technology. Vol.29, No.8, (2020). 3200-3204 pp. ISSN: 2005-4238 IJAST. Copyright 2020 SERSC.
4. Prepared on the basis of information from the Ministry of Housing and Communal Services of the Republic of Uzbekistan.
5. Кирсанов С.А. Зарубежный опыт управления многоквартирными домами // Журнал «ЖКХ: журнал руководителя и главного бухгалтера», № 10, 2011.

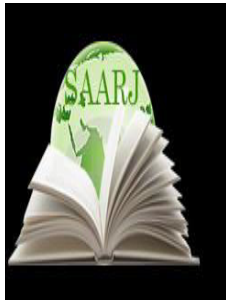

**ACADEMICIA**  
**An International  
 Multidisciplinary  
 Research Journal**  
 (Double Blind Refereed & Peer Reviewed Journal)

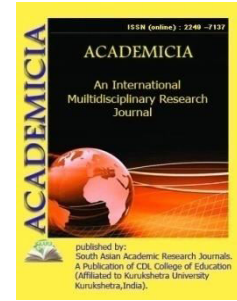

**DOI: 10.5958/2249-7137.2021.01901.7**

**STRATEGY FOR INCREASING THE INNOVATIVE POTENTIAL OF  
 ENTERPRISES OF THE CONSTRUCTION MATERIALS INDUSTRY IN  
 THE CONDITIONS OF INNOVATIVE ECONOMY”**

**Xaydarova Ezoza Shukrullayevna\***

\*Doctoral Student of the department "Management in Construction",  
 Tashkent Institute of Architecture and Civil Engineering,  
 UZBEKISTAN

Email id: xaydarovaezoza55@gmail.com

---

**ABSTRACT**

*The article discusses issues of innovative development of building materials industry of the region based on the cluster approach. Determined the significance of regional cluster development of the industry of construction materials as the effective implementation of the innovative breakthrough of the region as an important part of strategies for strengthening innovation activities may be to support the formation and development of cluster structures. Analyses the current situation with innovation in the building materials industry of the region based on the cluster approach. In the course of the study revealed a direct correlation between involvement in innovative activities on a cluster basis, and the level of development of industry of construction materials.*

**KEYWORDS:** *Innovative Development, Industrial Production, Innovative Economy, Enterprises.*

---

**INTRODUCTION**

If we pay attention to the structure of industrial production, in the past period of independence, fuel and energy, metallurgy, machinery and metal processing industries at a high rate we can see it growing. Mechanical engineering, construction materials industry and major branches of light industry: spinning and textile industry significantly, the development of consistently high rates systematic expansion of market reforms aimed at ensuring the next period is an important priority of structural changes in the industrial complex directions.

Growth rates in industrial sectors are in these sectors depending on the scale of internal and external demand for the products being created. In further increasing the real income and purchasing power of the country's population drastic expansion and improvement of the consumer credit system industry the share of domestic demand, which increases the volume of production in the complex characterized by an increase in The world of industrial products having a favorable conjuncture of market prices, international economic increased integration has a positive impact on industrial development and characterized by an increase in the influence of external factors.

The state in the structural changes made in the industrial complex fiscal policy, valuation and monetary policy, the economy in general as a result of the measures taken to reform one a number of positive shifts were achieved. Reform of industrial enterprises, structural restructuring, further increase in the share of private property in industry, networkshaping the management of enterprises on the basis of market principles industry plays an important role in its development.

The development of innovation and leadership in the global economy is the trend of development of science and technology policy, and this process does not depend on the type of state or of a political regime. However, the level of innovation in selected countries and regions is uneven. As a rule, it depends on the willingness of a particular State to organize the innovation process, to manage this process and regulate the relations arising in the sphere of innovations. In this context, it becomes relevant to use strategic approaches to innovation management, allowing purposefully lead the process. This strategic management of innovative activity should be carried out at the level of the Executive Innovation (Company), and the meso and macro levels - regional level, the industry, and the state as a whole. A key factor in the success of innovation in this situation, is the ability to link listed in the single-level strategy. In this paper, it is possible to implement it with the help of the new Uzbek economy forms of organization of economic subjects, science, infrastructure and state - clusters. Building materials industry is a major area of the economy, including more than 15 branches and forming the basis of the material and technical base of construction, the cost of building materials is the main section of the building complex costs.

At all times the status of the construction industry characterized the level of well-being and opportunities of development. In addition, the building complex, which includes the production of construction materials, plays a leading role in the economy of any region, and its condition is one of the indicators of economic and technological development. Despite the fact that the construction industry is quite conservative, the new conditions of the market economy, focused on the use of new technologies and resursos-beregayuschih materials led her to certain changes in investment-making insulating complex with intensive use of innovative programs. The need for innovation is dictated primarily demand to reduce the cost of construction and operation of housing, as well - reducing construction time and improve the quality of living[1].

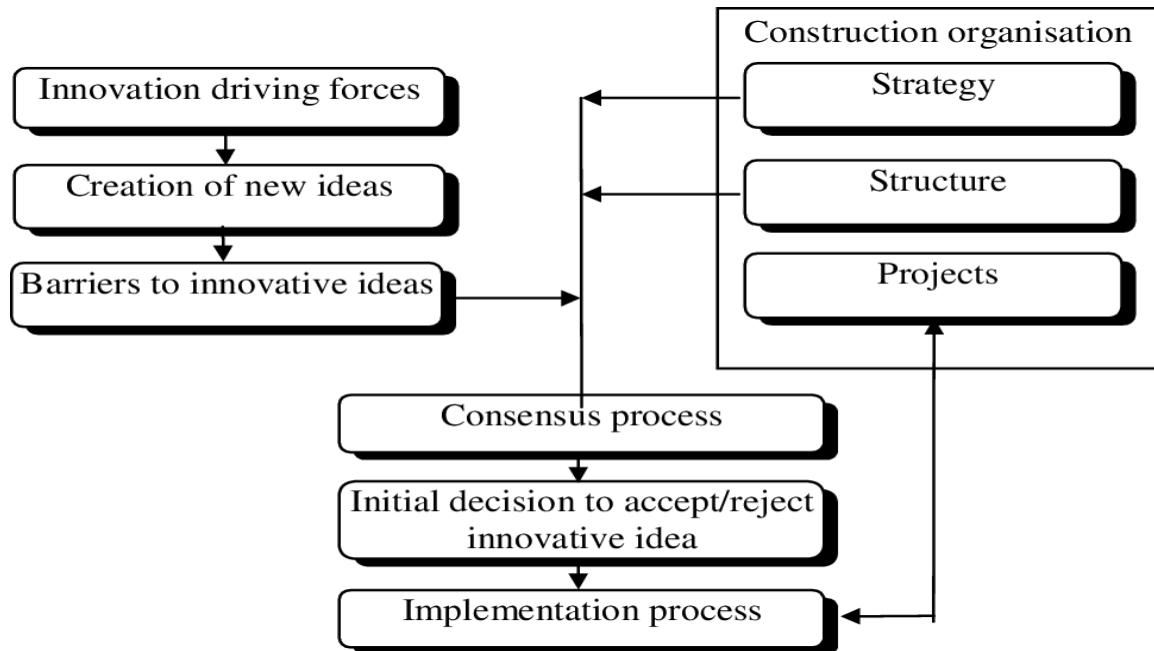

**Figure 1:** The dynamic framework of innovative construction organisation

The most important mechanism for the spread of innovation in the regional production clusters is a partnership of large companies with small and medium-sized businesses. The mechanisms of this partnership are outsourcing, subcontracting, implementation of joint programs, market research, training and other activities. Besides, the companies involved in the cluster, can benefit from the fact that businesses operate near the same sector or group of production, even if they do not interact with the competitors and in the development of new products. The benefit is to reduce transaction and production costs, lowering the barrier to exit the marketing and supply of raw materials markets. With the support of the government is gradually going evolutionary process of the consolidation of the manufacturers on the conditions of cooperation - to develop a common policy on procurement of raw materials for production, output at the federal regional product and foreign markets and the creation of a unified distribution structure [2].

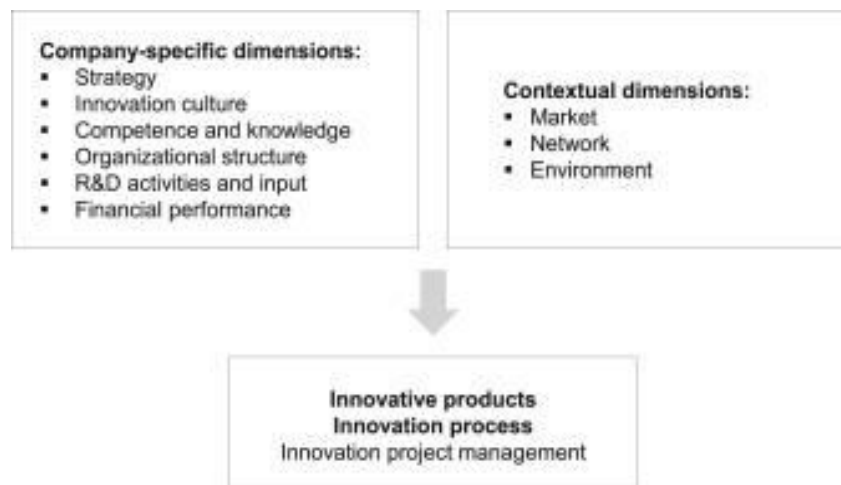

**Innovative process**

The proposed mechanism of the organization of innovative development of the industry of building materials in the region based on the cluster will create conditions for:

- Formation and realization of competent regional cluster policy in the field of construction;
- Transition to innovative development based on advanced modernization by concentrating resources on the most promising complementary groups of companies;
- Cooperation, outsourcing, subcontracting;
- The implementation of sectoral programs and investment projects;
- The development of fully integrated process chains in the field of building materials industry;
- Partnerships with large companies to small and medium-sized businesses;
- Agglomeration of several construction companies to achieve scale.

Research shows that there is currently no uniform state policy on development of the industry of building materials, including innovation. Strategic approaches are presented only at the level of individual regions. In this regard, is it necessary to the formation of a strategic approach to the development of innovative building materials industry. Formation of a regional building cluster in a given situation will link industry with the development of the study of public policy priorities, as well as with those of other participants of the construction sector and with scientific basis.

In addition, one of the reasons for lack of competitiveness of the industry is the lack of technological equipment with modern equipment such as industrial enterprises, as well as contractors. There are practically no production on the development and production of equipment for the creation of high-tech enterprises of the construction industry, modern means of transportation of materials [3].

In this regard, today we need to be able to combine modern domestic design and research experience, and giving them official status, are clearly distinguished in separate directions in development. All this requires the regional authorities to carefully plan and carry out work on the development of innovative activity in the construction industry, which aims to create conditions for the transition to the current scenario of the entire regional economy.

**CONCLUSION**

It should be noted that in most regions of the development of the industry of building materials prevents the monopolization of regional construction markets, the organization of which has a local character. Competitive contracting companies provided their access to raw materials and production bases. As a rule, the main developers in the regions – a vertically integrated company, having in its structure a career, plants. A lack of competitive environment limits their motivation to optimize the cost of construction products. To the traditional building materials industry to become one of the links in the global supply chain and not to lose not only engineering, but also domestic production, it is necessary to create an alternative construction industry on the basis of modern building science. Joining together in a cluster, it can carry out not only the construction companies, but also metallurgical concerns, organizing metal service centers and production of the metal, and logistics companies, providing a regular supply of materials, and other industries.

In addition, for the active development of the construction industry in the region, the modernization of old and creation of new enterprises, increase production capacity, enterprises snap high-tech equipment necessary to stimulate the sector, attracting investment into it by government policy, as well as the activities of professional societies. This entire means that the region will be able to provide not only the construction of any facilities, but also to produce diverse class housing.

**REFERENCES:**

1. V.Y. Khmelev, Time, 1, 22-26 (2011)
2. D. Sanatov, The era of traditional construction industry comes to an end, But the Industrial and Construction Review, 137, 6-8 (2011)
3. A.B. Mottaeva, The methodology of the spatial distribution of business organizations in the region based on the development of transport infrastructure (2012)
4. M.I. School, Organizational-economic mechanism of development of small premiership in territorial investment-building complex: Abstract (Cand. e. Sciences, Volgograd, 2008)



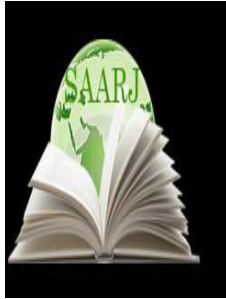

**ACADEMICIA**  
**An International**  
**Multidisciplinary**  
**Research Journal**  
 (Double Blind Refereed & Peer Reviewed Journal)

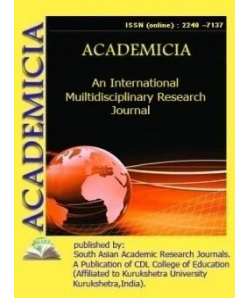

**DOI: 10.5958/2249-7137.2021.01902.9**

## CRAFTSMANSHIP THROUGH MUGS OF PRIMARY SCHOOL STUDENTS TARGETED REFERRAL TECHNOLOGIES

**Muxamadaliyeva Madinabonu Bohodirjon qizi\***

\*Teacher of the Department of Primary Education Methodology,  
Faculty of Preschool and Primary education of Fergana State University,  
UZBEKISTAN

### ABSTRACT

*Learning to recite passages from their holy text is a priority. For their society to advance, the oral tradition must be superseded by written texts; some students must go on and write down the passages. Monasteries students needed to read out what is written in the religious language and not just the vernacular. This led to formal education in madras as and schools. In one source from the turn of the 15th century, a French count advised that nobles' huntsmen should "choose a boy servant as young as seven or eight" and that "...this boy should be beaten until he has a proper dread of failing to carry out his masters orders." Education systems that promote education for justice, that is, respect for the rule of law (RoL) together with international human rights and fundamental freedoms strengthen the relationship between learners and public institutions with the objective of empowering young people to become champions of peace and justice.*

**KEYWORDS:** *Agriculture, Husbandry, Bartering, And Building Skills, Children Or Master To Apprentice.*

### INTRODUCTION

In pre-agrarian cultures, children learnt by following their instinct to play. There was no need for enforced education. In agrarian cultures, the skills of agriculture, husbandry, bartering, and building skills can be passed on from adults to children or master to apprentice. Societies agree on the need for their children to learn and absorb their cultural traditions and beliefs and they attempt to do this informally in the family, or by gathering the children together and employing one adult to handle the task, a tutor. This worked well for the landowners, but the children of the landless would be employed from the age of seven as servants. In one source from the turn of the 15th century, a French count advised that nobles' huntsmen should "choose a boy servant as

young as seven or eight" and that "...this boy should be beaten until he has a proper dread of failing to carry out his masters orders." The document listed chores that the boy would perform daily, and that the boy would sleep in a loft above the kennels in order to attend to the hounds' needs.

Religious communities become providers of education and defined the curriculum. Learning to recite passages from their holy text is a priority. For their society to advance, the oral tradition must be superseded by written texts; some students must go on and write down the passages. Monasteries students needed to read out what is written in the religious language and not just the vernacular. This led to formal education in madrassas and schools. Martin Luther declared that salvation depends on each person's own reading of the Scriptures. Trading and management create a demand for accountancy. Basic skills thus included literacy and numeracy. This was the core of Elementary Education.

Schools play an important role in children's socialization and in developing their appreciation of sharing, fairness, mutual respect and cooperation. Schools form the foundational values and competencies that are the building blocks towards the understanding of concepts such as justice, democracy and human rights.

Education systems that promote education for justice, that is, respect for the rule of law (RoL) together with international human rights and fundamental freedoms strengthen the relationship between learners and public institutions with the objective of empowering young people to become champions of peace and justice. Teachers are often on the front line of this work and, along with families, play a formative role in shaping children's attitudes and behaviors.

Global citizenship education provides the overall framework for the approach to the Roll. It aims to empower learners to engage and assume active roles, both locally and globally, as proactive contributors to a more just, peaceful, tolerant, inclusive, secure and sustainable world.

Whether you're a longtime educator, preparing to start your first teaching job or mapping out your dream of a career in the classroom, the topic of teaching methods is one that means many different things to different people.

Your individual approaches and strategies to imparting knowledge to your students and inspiring them to learn are probably built on your academic education as well as your instincts and intuition.

Whether you come by your preferred teaching methods organically or by actively studying educational theory and pedagogy, it can be helpful to have a comprehensive working knowledge of the various teaching methods at your disposal.

He teacher-centered approach vs. the student-centered approach. High-tech vs. low-tech approaches to learning. Flipped classrooms, differentiated instruction, inquiry-based learning, personalized learning and more.

Not only are there dozens of teaching methods to explore, it is also important to have a sense for how they often overlap or interrelate. One extremely helpful look at this question is offered by the teacher-focused education website Teach.com.

"Teaching theories can be organized into four categories based on two major parameters: a teacher-centered approach versus a student-centered approach, and high-tech material use versus

low-tech material use,” according to the informative, which breaks down a variety of influential teaching methods as follows:

### **Teacher-Centered Approach to Learning**

Teachers serve as instructor/authority figures who deliver knowledge to their students through lectures and direct instruction, and aim to measure the results through testing and assessment. This method is sometimes referred to as “sage on the stage.”

### **Student-Centered Approach to Learning**

Teachers still serve as an authority figure, but may function more as a facilitator or “guide on the side,” as students assume a much more active role in the learning process. In this method, students learn from and are continually assessed on such activities as group projects, student portfolios and class participation.

### **High-Tech Approach to Learning**

From devices like laptops and tablets to using the internet to connect students with information and people from around the world, technology plays an ever-greater role in many of today’s classrooms. In the high-tech approach to learning, teachers utilize many different types of technology to aid students in their classroom learning.

### **Direct Instruction (Low Tech)**

Under the direct instruction model — sometimes described as the “traditional” approach to teaching — teachers convey knowledge to their students primarily through lectures and scripted lesson plans, without factoring in student preferences or opportunities for hands-on or other types of learning. This method is also customarily low-tech since it relies on texts and workbooks rather than computers or mobile devices.

### **Flipped Classrooms (High Tech)**

What if students did the “classroom” portion of their learning at home and their “homework” in the classroom? That’s an oversimplified description of the flipped classroom approach, in which students watch or read their lessons on computers at home and then complete assignments and do problem-solving exercises in class.

### **Kinesthetic Learning (Low Tech)**

In the kinesthetic learning model, students perform hands-on physical activities rather than listening to lectures or watching demonstrations. Kinesthetic learning, which values movement and creativity over technological skills, is most commonly used to augment traditional types of instruction — the theory being that requiring students to do, make or create something exercises different learning muscles.

### **Low-Tech Approach to Learning**

Technology obviously comes with pros and cons, and many teachers believe that a low-tech approach better enables them to tailor the educational experience to different types of learners. Additionally, while computer skills are undeniably necessary today, this must be balanced against potential downsides; for example, some would argue that over-reliance on spell check and autocorrect features can inhibit rather than strengthen student spelling and writing skills.

**CONCLUSION**

In addition to the many philosophical and pedagogical approaches to teaching, classroom educators today employ diverse and sometimes highly creative methods involving specific strategies, prompts and tools that require little explanation

**REFERENCE**

1. A NEW STAGE OF REFORMING THE TRAINING OF LEGAL PERSONNEL. F Mukhitdinova Review of law sciences 2 (1), 2017
2. Ideas and teachings on the concept of spiritual and moral education of the younger generation in Uzbekistan FA Mukhitdinova, SS Agzamkhodzhayeva Eurasian Union of Scientists, 2019
3. Problems of power and management in the works of Eastern thinkers FA Mukhitdinova, HM Mukhammedov High School, 35-38, 2015
4. Implementation of human rights protection in Uzbekistan IV Kudryavtsev Eurasian Union of Scientists, 2019
5. The origins of the idea of civil society FA Mukhitdinova, IN Kudryavtsev ACTUAL ASPECTS OF MODERN SCIENCE, 102-109, 2017

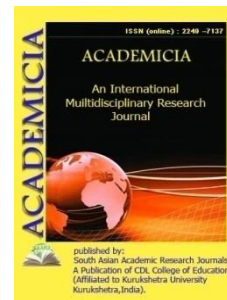
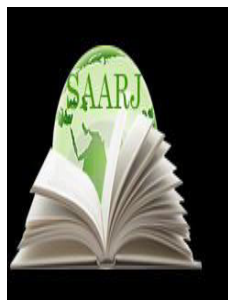

DOI: **10.5958/2249-7137.2021.01903.0**

## **PRODUCTION AND STORAGE TECHNOLOGY APPLE CHIPS**

**Karimova Dilnoza Zafarjanovna\* ; Akramov Umidilla Ikramdjanovich\*\***

\*Assistant,  
Urgench State University,  
UZBEKISTAN

\*\*Associate Professor,  
Candidate of Agricultural Sciences, Tashkent State Agrarian University,  
UZBEKISTAN

### **ABSTRACT**

*This scientific article is devoted to the development of technology for the production of chips from apples zoned in Uzbekistan, which allows to preserve the micronutrients of the original plant raw materials as much as possible and to obtain a safe product with high organoleptic properties, increased nutritional value, useful for all age groups of the population.*

**KEYWORDS:** *Apples, Value, Chips, Technology, Products, Storage*

### **INTRODUCTION**

Fast food, breakfast cereals and snacks are becoming a familiar part of modern consumer culture. The most important direction of the development of the processing industry and agricultural production is the improvement of technologies for preparing fast food products, namely, obtaining natural, full-fledged and light food with high shelf life without the use of artificial food additives [1].

The assortment of chips produced in Uzbekistan is 80% represented by potato and grain processing products, while the use of fruits, in particular apple fruits, is a promising direction. According to statistics, the gross harvest and yield of seed crops in Uzbekistan increases annually.

A growing trend that is actively developing abroad is the production of fruit slices, including from apples fried in oil. At the same time, the finished product has a specific pleasant taste and aroma with a "crispy" consistency characteristic of chips [2].

Sweet and sour apple varieties, in particular Jonathan, Reinnet Simirenko, are suitable for canning by dehydration, and Red Scarlett and Impala varieties with a low amount of reducing sugars are suitable for potato root crops. It is recommended to use round-shaped raw materials with a cross-sectional size of 45-65 mm to reduce the appearance of broken finished products in packaging during production and subsequent storage [3].

The above indicates that apple processing is a multi-level system characterized by the interconnection of all links with each other. Therefore, the development of technology and technical means of mechanical and thermal processing of vegetable raw materials is a comprehensive solution to the problem of increasing the efficiency of fruit processing by reducing the content of harmful ingredients in finished fast food products by improving the technological process, as well as minimizing the energy costs of the equipment used [2,3, 4, 5, 6].

In the production of chips, a number of oxidative processes of fats and the undesirable formation of carcinogenic substances that adversely affect the human body occur. In addition, a high mass fraction of oil in the finished product causes rancidity, a decrease in the quality characteristics of the product, followed by damage to the entire contents of the package. It follows from this that a uniform residual moisture content of the material is achieved by the same thickness of all slices. At the same time, equal conditions are created during the heat treatment of the material with the possibility of obtaining products uniform in oil content. With this in mind, the development and justification of optimal technological modes for grinding fruit and vegetable raw materials and subsequent frying of the obtained slices is an urgent task of the agro-industrial complex [4, 5, 6].

Theoretical and experimental studies of the process of cutting fruit and vegetable raw materials into slices and subsequent frying in vegetable oil with minimal energy and material costs, as well as high yield of high-quality finished products without defects are an obvious resource-saving factor and are of great scientific and practical importance [6].

The studies of S.A. Arnaut, Z.Lovkis, V.V.Yakimtov and others are devoted to improving the efficiency of the technological process and technical means of cutting apples. They have developed a number of disc-type cutting machines, which have disadvantages expressed in some low technical characteristics, namely limited productivity, increased energy consumption and a high percentage of products with different granulometric composition [4, 5].

However, the tasks of their research did not include the selection of varieties of apple raw materials for the manufacture of chips. There are also practically no comprehensive studies of scientists on the development of competitive technology for the production of apple chips, and the available data relate to the scientific justification of the parameters of cutting apple fruit into plates.

## RESULTS AND DISCUSSIONS

The results of the conducted research have developed a technology for producing apple chips (Figure), which can be implemented at any canning enterprise equipped with a cutting machine, as well as blanking equipment and a convective dryer.

To obtain apple chips with high consumer properties and maximally preserved nutrients, the raw materials cut into plates with a thickness of 1.5-2.0 mm must be blanched in a solution containing 35% sucrose, 1% ascorbic acid, 1% citric acid for 3-5 minutes at a temperature of 75



° C, and further convective drying should be carried out at a temperature of 80 ° C drying agent and a speed of 0.5 m / s drying agent, to a mass fraction of moisture less than 9 %

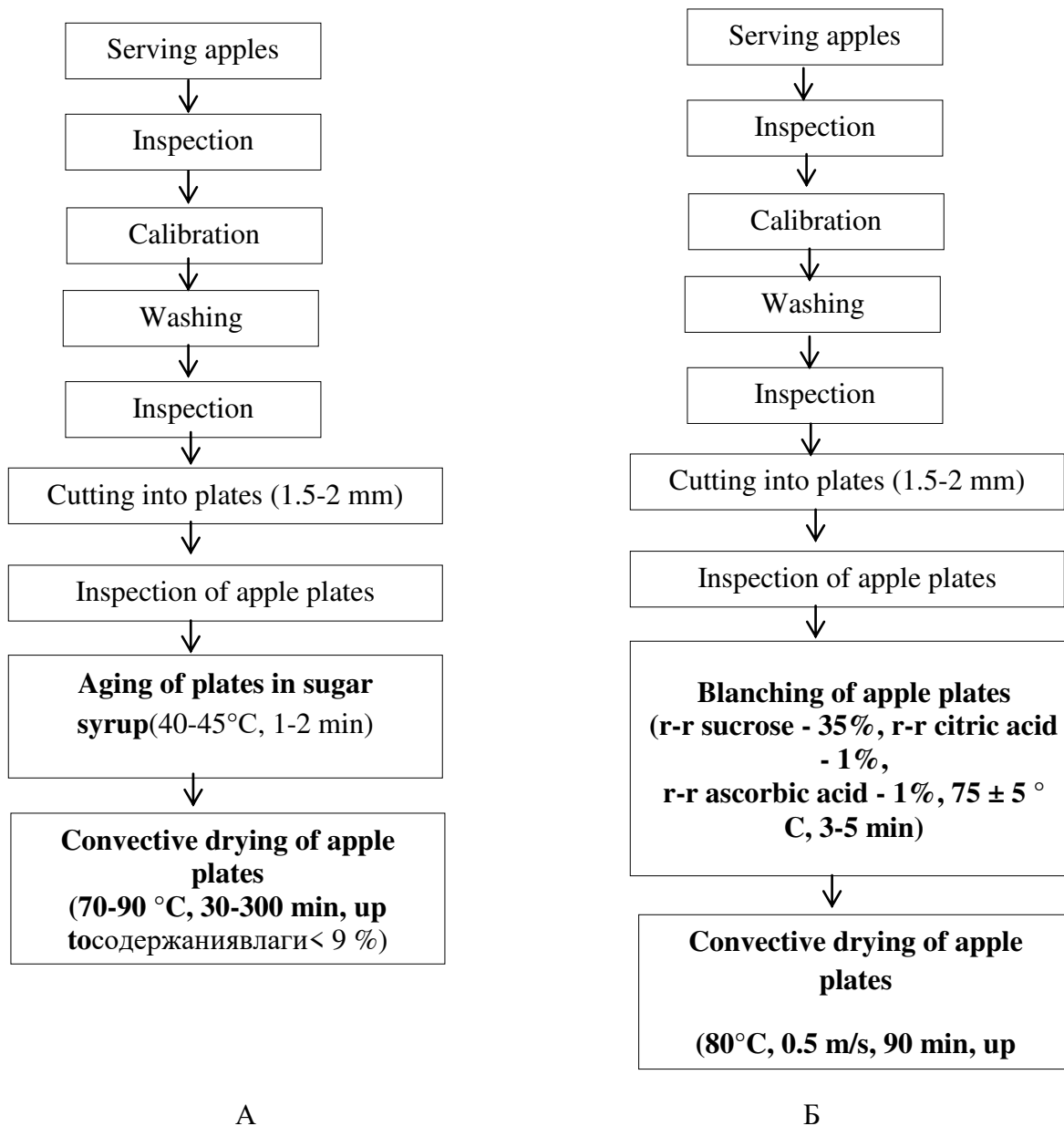

**Figure** Existing (A) and proposed technology (B) scheme of apple chips production

The results of studies of physico-chemical and biochemical parameters of experimental samples of chips made according to the developed technology indicate that its use ensures the production of finished products with maximum preservation of macro- and micronutrients of the feedstock (mass fraction of titrated acids ( $2.0 \pm 0.2$ )%, total sugars - ( $68.1 \pm 6.8$ )%, ascorbic acid content - ( $3.5 \pm 1.7$ ) mg / 100g, pectin substances - ( $8.5 \pm 3.2$ )%).

It was shown that apple chips are a source of minerals, the average content of which was as follows: potassium - 263.15 mg/100 g, calcium - 36.12 mg/100 g, iron - 1.37 mg/100 g, sulfur -

43.19 mg/100 g, manganese - 0.13 mg/100 g, nickel - 0.02 mg/100 g, copper - 0.09 mg/100 g. When eating 100 g of the product, a person's daily need is satisfied on average in Fe by 21%, S and K - by 12%, Si - by 9%, Mp and Ni - by 7%, Ca - by 6%.

The data on the total quantitative composition of amino acids of apple chips (from 305 to 1707 mg /100 g of dry matter) are new, while the proportion of essential amino acids is 24-40%, which confirms the high biological value of apple chips.

The study of the dynamics of organoleptic, physico-chemical and microbiological parameters of apple chips during storage allowed us to establish that after 4 months of storing products in polymer packaging, the organoleptic properties of chips deteriorated, expressed in the loss of crispy consistency and deterioration of color, there was also a change in physic-chemical parameters (table): the content of ascorbic acid decreased 4.4 times, the moisture content increased by 10% and the amount of water activity by 14%.

#### Physic-chemical parameters of apple chips during storage

Shelflife, month	The name of the indicator		
	Ascorbic acid content, mg/100 g	Titrated acidity, %	Content 5-hydroxymethylfurfural, mg/100 g SV
0	2,70	2,05	2,0
4	1,37	2,00	2,0
6	0,61	1,90	2,1

However, despite these changes, the quantitative composition of the microbiota and the concentration of 5-hydroxymethylfurfural in apple chips remained almost at the same level during the entire shelf life. Thus, the data obtained made it possible to establish the shelf life of apple chips in polymer bags without vacuuming - 4 months.

#### CONCLUSION

To obtain apple chips with a crispy consistency, aroma and color of the raw material containing (on average from the initial amount in the raw material) 18% ascorbic acid, 84% flavones, 86% of the total amount of catechins and Lecco anthocyanins, convective drying of blanched apple plates must be carried out at a drying agent temperature of 80 ° C and its speed of 0.5 m / s.

The optimality of these modes is confirmed by the low content of 5-hydroxymethylfurfural (no more than 2.2 mg /100 g) and the amount of water activity (no more than 0.40), as well as the complete inactivation of ascorbate oxidase, per oxidase and polyphenol oxidase, which guarantees the durability of the product during storage.

#### REFERENCE

1. Antonov N.M., Lebed N.I. Determination of some energy parameters of static cutting of apple fruits // Izvestiyanizhne-volzhskeyagrouniversitetskiy complex: Science and higher professional education. VolGAU. - Volgograd, 2014. – №2 (34). – Pp. 143-148.
2. Antonov N.M., Lebed N.I. Obtaining optimal modes of the roasting process for slices of apple fruit and potato root crops // Izvestia of the Nizhnevolzhskeyagrouniversitetskiy complex: science and higher professional education. VolGAU. - Volgograd, 2014. –№ 3(43). – Pp. 185-192.

3. Arnaut S.A. Theoretical foundations of thin-layer apple cutting // National Academy of Sciences of Belarus, Council of Young Scientists of the National Academy of Sciences of Belarus. - Minsk: Belorusskayanauka, 2008. - Ch. 4: Series of agricultural sciences. - p. 312.
4. Korolev A.A. Development of technology of fruit and vegetable chips: abstract. diss. candidate of technical Sciences. - Moscow, 2013. - 24 p.
5. Lebedev N.I., Antonov N.M. The influence of the roasting process on the properties of chips // Machinery and equipment for the village. FSBI "rOsinformagrotech". - Moscow, 2016. - No. 7. - pp.34-38
6. Litvinov E.V. Scientific support of the process of combined convective - microwave drying in the production of apple chips: diss. kan. tech. sciences. - Voronezh, 2013. - 323 p.



**ACADEMICIA**  
**An International**  
**Multidisciplinary**  
**Research Journal**  
 (Double Blind Refereed & Peer Reviewed Journal)

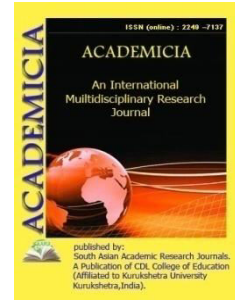

**DOI: 10.5958/2249-7137.2021.01904.2**

## THE ROOTS OF SOME ALGEBRAIC EQUATIONS ONE WAY TO DETERMINE

**Abdusalom Hakimov\*; Baxiyor Hayitovich Ungarov\*\*; Maftuna Abdinazarova\*\*\***

\*Associate Professor,  
 Navoi State Pedagogical Institute,  
 UZBEKISTAN

\*\*Senior Teacher,  
 Navoi State Pedagogical Institute,  
 UZBEKISTAN

\*\*\*Student,  
 UZBEKISTAN

### ABSTRACT

*In the article  $e^{ix} = \cos x + i \sin x$  The Eyley formula was proved with the help of excellent limits, as well as with the help of which the method of determining the roots of some complex coefficients of algebraic equations was used.*

**KEYWORDS:** *Eyley's Formula, Algebraic Equations, Root, Komplex Numbers, Trigonometric Form, Striking Limits.*

### INTRODUCTION

The Eyley formula  $e^{ix} = \cos x + i \sin x$  (1) the real variable represents a link between the function and the theory of theses variable function, and this plays an extremely important role. This article (1) Eyley's formula is devoted to the determination of solutions of an algebraic equation.

The theorem. The following attitude is appropriate  $e^{ix} = \cos x + i \sin x$ .

Proof: to prove the theorem, below we use certain limits and formula.

$$\lim_{n \rightarrow \infty} \left(1 + \frac{\alpha}{n}\right)^n = e^{\alpha} \quad (2)$$

$$\lim_{x \rightarrow 0} \frac{\sin x}{x} = \lim_{x \rightarrow 0} \frac{\arcsin x}{x} = \lim_{x \rightarrow 0} \frac{\sin x}{\arcsin x} = \lim_{x \rightarrow 0} \frac{\sin x}{x} = \lim_{x \rightarrow 0} \frac{\arcsin x}{x} = 1 \quad (3)$$

$$(x + iy) = z(\cos \varphi + i \sin \varphi) \quad (4);$$

$$z = \sqrt{x^2 + y^2}$$

$$\varphi = \begin{cases} \arctg \frac{y}{x} \text{ agar } x > 0 \\ \pi + \arctg \frac{y}{x} \text{ agar } x < 0 \end{cases}$$

(2) if we look at  $\alpha=xi$ :

$$\lim_{n \rightarrow \infty} \left(1 + \frac{xi}{n}\right)^n = e^{xi} (x + iy) = z(\cos \varphi + i \sin \varphi) \quad (5)$$

$$z = \sqrt{x^2 + y^2};$$

$$\left(1 + \frac{xi}{n}\right) = z(\cos \varphi + i \sin \varphi), \quad z = \sqrt{1 + \frac{x^2}{n^2}};$$

$$\varphi = \arctg \frac{x}{n}$$

$$\left(1 + \frac{xi}{n}\right)^n = z^n \cdot (\cos n\varphi + i \sin n\varphi); \quad (6)$$

Putting (6) to (5),

$$\lim_{n \rightarrow \infty} \left(1 + \frac{xi}{n}\right)^n = \lim_{n \rightarrow \infty} \left(1 + \frac{x^2}{n^2}\right)^{\frac{n}{2}} \cdot (\cos n\varphi + i \sin n\varphi); \quad (7)$$

$$\lim_{n \rightarrow \infty} \left(1 + \frac{x^2}{n^2}\right)^{\frac{n}{2}} \cdot \left(\frac{x^2}{n}\right) = \lim_{n \rightarrow \infty} e^{\frac{x^2}{n}} = 1; \quad (8)$$

$$\lim_{n \rightarrow \infty} n\varphi = \lim_{n \rightarrow \infty} n \cdot \frac{\arctg \frac{x}{n}}{n} = x; \quad (9)$$

The above attitude can be cited. Taking into account (7) and (8) formulas, (6) can be expressed as follows.

$$\lim_{n \rightarrow \infty} \left(1 + \frac{xi}{n}\right)^n = \cos x + i \sin x$$

Now let's look at the practical issues concerning the application of the above theorem and formula.

$$1. \quad f(x) = x^m - c_{2m}^2 x^{m-1} + c_{2m}^4 x^{m-2} + \dots + (-1)^m c_{2m}^{2m};$$

Determine the roots of the polynomial and divide  $\mathbb{R}$  into multipliers in the area of real numbers' (x) to determine the real coefficients of a polynomial and its roots, let's add the following function and denote  $f(x)$  in their means:

$$F(x + i) = (\sqrt{x} + i)^{2m}; \quad F(\overline{x + i}) = (\sqrt{x} - i)^{2m};$$

$$f(x) = \frac{1}{2} \left( F(x + i) + F(\overline{x + i}) \right)$$

$$F(x+i) = (\sqrt{x}+i)^{2m} = z^{2m}(\cos n\varphi + i \sin n\varphi)^{2m} = z^{2m}(\cos 2m\varphi + i \sin 2m\varphi)$$

$$F(\overline{x+i}) = z^{2m}(\cos 2m\varphi - i \sin 2m\varphi)$$

Given the above, it is possible to write f(x) in the following form:

$$f(x) = \frac{F(x+i) + F(\overline{x+i})}{2} = z^{2m} \cdot \frac{e^{2m\varphi i} + e^{-2m\varphi i}}{2} = z^{2m} \cos 2m\varphi;$$

$$\text{In here } z = \sqrt{x+1}, x > 0, \varphi = \text{arctg} \frac{1}{\sqrt{x}} = \text{arcctg} \sqrt{x};$$

$$f(x) = 0 \Rightarrow z^{2m} \cos 2m\varphi = 0; z \neq 0 \Rightarrow \cos 2m\varphi = 0; \cos 2m\varphi = \cos\left(\frac{\pi}{2} + \pi\kappa\right);$$

$$2m\varphi = \frac{\pi}{2} + \pi\kappa \Rightarrow \varphi = \frac{\pi}{4m}(1 + 2\kappa); \text{arcctg} \sqrt{x} = \frac{\pi}{4m}(1 + 2\kappa);$$

$$\text{ctg}(\text{arcctg} \sqrt{x}) = \text{ctg} \frac{\pi}{4m}(1 + 2\kappa);$$

$$\sqrt{x} = \text{ctg} \frac{\pi}{4m}(1 + 2\kappa) \Rightarrow x = \text{ctg}^2 \frac{\pi}{4m}(1 + 2\kappa);$$

Given here  $\cos x = 0$ , the period of the roots of the equation is  $\pi\kappa$ :  $F(x)=0$  write down the different roots of the equation

$$x_k = \text{ctg}^2 \frac{2\pi}{4m}(1 + 2\kappa), \quad \kappa = \overline{0, m-1}$$

According to the main theorem of algebra, it is possible to bring the multiplication of f(x) relative to the roots.

$$f(x) = 2 \prod_{k=0}^{m-1} \left( x - \text{ctg}^2 \frac{\pi}{4m}(1 + 2k) \right)$$

$$2. f(x) = (x + \cos \theta + i \sin \theta)^n + (x + \cos \theta - i \sin \theta)^n;$$

$$\phi_1(x) = F_1(x + \cos \theta + i \sin \theta) = (x + \cos \theta + i \sin \theta)^n;$$

$$\phi_2(x) = \phi_1(\overline{x}) = F_1(\overline{x + \cos \theta + i \sin \theta}) = (x + \cos \theta - i \sin \theta)^n;$$

$$f(x) = \phi_1(x) + \phi_2(x)$$

$$x + \cos \theta + i \sin \theta = \sqrt{x^2 + 2x \cos \theta + 1} (\cos \varphi + i \sin \varphi) = \sqrt{x^2 + 2x \cos \theta + 1} \cdot e^{i\varphi}$$

$$\overline{x + \cos \theta + i \sin \theta} = \sqrt{x^2 + 2x \cos \theta + 1} (\cos \varphi - i \sin \varphi) = \sqrt{x^2 + 2x \cos \theta + 1} \cdot e^{-i\varphi},$$

$$\varphi = \text{arctg} \frac{\sin \theta}{x + \cos \theta} = \text{arctg} \frac{x + \cos \theta}{\sin \theta}$$

$$\phi_1(x) = (\sqrt{x^2 + 2x \cos \theta + 1})^n \cdot (\cos n\varphi + i \sin n\varphi) = z \cdot e^{n\varphi i}$$

$$\phi_2(x) = (\sqrt{x^2 + 2x \cos \theta + 1})^n (\cos n\varphi - i \sin n\varphi) = z^n \cdot e^{-n\varphi i}.$$

$$z = \sqrt{x^2 + 2x \cos \theta + 1}$$



On the basis of the above substitutions marks, it is possible to write  $f(x)$  in the following form.

$$f(x) = (\sqrt{x^2 + 2x \cos \theta + 1})^n \frac{(e^{n\varphi i} + e^{-n\varphi i})}{2} = 2(\sqrt{x^2 + 2x \cos \theta + 1})^n \cdot \cos n\varphi,$$

$$f(x) = 0$$

$$\sqrt{x^2 + 2x \cos \theta + 1} \cdot \cos n\varphi = a$$

$$x^2 + 2x \cos \theta + 1 \neq 0, \quad \cos n\varphi = 0$$

$$\cos n\varphi = \cos \left( \frac{\pi}{2} + \pi\kappa \right)$$

$$\operatorname{arccctg} \frac{x + \cos \theta}{\sin \theta} = \frac{\pi}{2} (1 + 2\pi\kappa) \operatorname{arccctg} \frac{x + \cos \theta}{\sin \theta} = \frac{\pi}{2n} (1 + 2\kappa)$$

$$\operatorname{ctg} \left( \operatorname{arccctg} \frac{x + \cos \theta}{\sin \theta} \right) = \operatorname{ctg} \frac{\pi}{2n} (1 + 2\kappa) \frac{x + \cos \theta}{\sin \theta} = \operatorname{ctg} \frac{\pi}{2n} (1 + 2\kappa)$$

$$x = \sin \theta \operatorname{ctg} \left( \frac{\pi}{2n} (+2\kappa) - \cos \theta \right) x_\kappa = \sin \theta \left( \operatorname{ctg} \frac{\pi}{2n} (1 + 2\kappa) - \cos \theta \right) \kappa = \overline{0, n-1}$$

$$f(x) = 2 \prod_{\kappa=0}^{n-1} \left( x + \cos \theta - \sin \theta \operatorname{ctg} \frac{\pi}{2n} (1 + 2\kappa) \right)$$

3.  $f(x) = c_n^1 x^{n-1} - c_n^3 x^{n-3} + c_n^5 x^{n-5} + \dots$  let's define the roots of the polynomial, and then divide them into multipliers, for this we will add the denominators to the polynomial.

$$F_1(x+i) = (x+i)^n; \quad F_2(x+i) = \overline{F(x+i)} = (x-i)^n;$$

$$f(x) = \frac{(F_1(x+i) - \overline{F_2(x+i)})}{2i} = \frac{(x+i)^n - (x-i)^n}{2i};$$

$$(x+i)^n = (\sqrt{x^2+1})^n \cdot e^{n\varphi i}; \quad (x-i)^n = (\sqrt{x^2+1})^{\frac{n}{2}} \cdot e^{-n\varphi};$$

$$\varphi = \operatorname{arctg} \frac{1}{x} = \operatorname{arccctg} x$$

$$f(x) = (\sqrt{x^2+1})^n \frac{(e^{n\varphi i} - e^{-n\varphi i})}{2} = (\sqrt{x^2+1})^n \sin n\varphi$$

$$f(x) = 0 \Rightarrow \sqrt{x^2+1} \neq 0 \Rightarrow \sin \varphi = 0$$

$$\sin n\varphi = \sin \pi\kappa, \quad \varphi = \frac{\pi\kappa}{n} \Rightarrow \operatorname{arccctg} x = \frac{\pi\kappa}{2} \Rightarrow \operatorname{ctg}(\operatorname{arccctg} x) = \operatorname{ctg} \frac{\pi\kappa}{2}.$$

$$x = \operatorname{ctg} \frac{\pi\kappa}{n}, \quad \kappa = \overline{1, n-1}$$

$$f(x) = c_n^1 x^{n-1} - c_n^3 x^{n-3} + \dots = c_n^1 \prod_{\kappa=1}^{n-1} \left( x - \operatorname{ctg} \frac{\pi\kappa}{n} \right)$$

The Euler formula can be applied to the solution of complex coefficient equations similar to the above [1; 2]. The method used above plays an important role in the development of the dynamics of independent performance of students.

#### REFERENCE

1. C.Zire " Lost In Test Match Maksudav, M.Salakhiddinov. "Theory of functions of the complex variable". Publishing house "teacher", Tashkent - 1979.
2. D.K.Faddeev, I.S.Sominsky. Collection of problems in higher algebra. Nauka Publishing House, Moscow- 1972.
3. B.A.Fuchs, I.B.Shabbat. Functions of a complex variable and some of their applications. Fizmatgiz, 1969.
4. D.N.Ashurova, Kadirova Sh.T. Some functions are about an innovative way of calculating Class limits. Knowledge wrappers. Scientific and methodical Journal, UrDU, Number 4, 2020 Year, 11-14 p.



**ACADEMICIA**  
**An International  
Multidisciplinary  
Research Journal**  
(Double Blind Refereed & Peer Reviewed Journal)

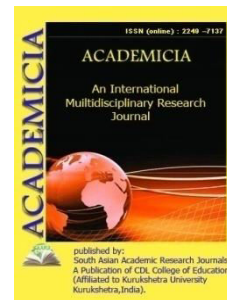

DOI: **10.5958/2249-7137.2021.01894.2**

## **CALORIC DELINEATION OF BOTH GASOLINE AND DIESEL BLENDS USING DSC**

**Dr. K. Prahlada Rao\***; **Kothagundu Subrahmanyam\*\***

\*Professor,

Department of Mechanical Engineering,  
Jntua Anantapur, Andhra Pradesh, INDIA  
Email id: subramaiankothagundu@gmail.com

\*\*Research scholar Dept of Mechanical,  
Jntua Anantapur, Andhra Pradesh, INDIA

Email id: subrahmanyamkothagundu@gmail.com

### **ABSTRACT**

*Today, one of the most serious issues associated with the use of internal combustion engines is the emission of harmful gases. In researching alternative sources of energy, there has been an increase in concern about the need for energy resources and the environmental and demand impacts of fuel sources. To meet this criterion, biodiesels will play an important role as an alternative to diesel oil because they are renewable and have similar properties. Petroleum products are currently being consumed at a rate that will lead to depletion in the coming decades. Ethanol usage in transportation is one of the sectors that can meet the requirement while also helping to reduce vehicle greenhouse gas emissions. The application of thermo gravimetric analysis to renewable energy sources is a novel study that has gained popularity among researchers in recent years. In this mainly focus on differential scanning calorimeter(DSC) of various blends to investigate the (TG-DSC) thermal behavior of Petrol, Diesel, Ethanol blends(E5,E10,E20),J atropa oil and waste cooking oil blends all the thermo grams of heat flow is exhibited at 35°C -300°C temperature range at air atmosphere ,The main aim of the study to observe the combustion behavior of both petrol and diesel blends, the origin of biodiesel blends have been analyzed to observe the transesterification reaction effect on biodiesel. Therefore, the petrol and biodiesel blends at different percentages are exposed to isothermal heating rates under nitrogen and air atmosphere with a constant heat rate by using DSC.*

**KEYWORDS:** *Differential Scanning Calorimeter, Combustion, Thermo Gravimetric, Bio-Diesel Blends, Thermo Grams.*

## **1. INTRODUCTION**

Due to the increasing scarcity of petroleum resources around the world, we are compelled to look for alternative fuels to meet the demand for fuels. Among the various alternative fuels such as LPG, biodiesel, hydrogen, ethanol, battery, and so on, biodiesel occupies a notable and significant position. Many research experts now believe that the world's supply of petroleum products will be depleted within the next 40 to 60 years. As a result, there is an increase in research into effective petroleum substitutes. According to a report, produced in India only 30 to 40% of its total petroleum requirements for consumption, with the remaining 70% imported from other countries at a cost of approximately Rs.10,00000 million per year. It is certain that blending 5% bio - diesel with current diesel will save Rs.40,000 million per year.[1]

Biodiesel was introduced in the 1990s as a result of global warming, greenhouse gas emissions from vehicles, and its advantages over regular diesel, such as non-sulfur emissions, low toxicity, biodegradability, and Eco friendliness. Biodiesel is made from renewable sources such as fresh or used vegetable oils, animal fats, and so on. In terms of Cetane number, flashpoint, lubricity, and exhaust emissions, it outperforms diesel fuels. It can be blended with conventional diesel in certain proportions and used to power any existing conventional CI engine with no engine modifications required.[2-3]

Transesterification is the process of converting vegetable oil into biodiesel fuel, and it is fortunately less complicated than it sounds. Chemically, transesterification is the process of using an alcohol (e.g., methanol, ethanol, or butanol) in the presence of a catalyst, such as sodium hydroxide or potassium hydroxide, to chemically break the molecule of raw renewable oil into methyl or ethyl esters of the renewable oil, with glycerol as a byproduct. If the reaction's reagent is methanol, the biodiesel is referred to as methanol route biodiesel; if the alcohol agent is ethanol, the biodiesel is referred to as ethanol route biodiesel. [4]

A lot of research has been carried out by many researchers worldwide to investigate the possibility of biodiesel instead of diesel. Among the studies, using thermogravimetric methods to investigate the thermal behavior of biodiesel and its blends with diesel is a novel and unexplored topic. Although the use of thermogravimetry (TGA/DTG) and differential scanning calorimeters (DSC) in petroleum derivatives has grown in popularity among researchers, its application to biodiesel is a relatively new and promising technology.[5]TGA/DTG and DSC were used in this study to perform thermogravimetric analysis on diesel, biodiesel, canola oil, and biodieseldiesel blends. Experiments are conducted in nitrogen and air atmospheres at some heating rate to investigate the pyrolysis and combustion properties of the fuels.[6-7]

Calorimetric measurements yield a DSC curve, which represents the temperature/time dependence on heat flux. Endo- and exothermic peaks are recorded on these curves as a result of temperature differences between a tested sample and a reference sample, indicating negative or positive deviations from the so-called "baseline," which is recorded when no transformations/reactions occur in the sample. The variations are caused by phase transformations and chemical reactions that occur in the material. Heat is absorbed when the temperature of a tested sample during the phase transformation/chemical reaction falls below the reference temperature. The heat has been absorbed; this is referred to as the endothermic peak.

When the sample temperature rises and heat separates, this is indicated by the exothermic effect on the DSC curve.[8-9]

## **2.Experimental procedure:**

T-zero calibration, or temperature check, is performed in two steps. The first step is to obtain the baseline using no pans or samples. The second operation is performed with the sapphire material alumina with pan placing on both reference positions. The cell is preheated in both operations, and the initial equilibrium temperature remains isothermal for 5 minutes. Since the samples are liquids and volatile, temperature zero mass aluminum pans are appropriate. Temperature and sensitivity tests had been performed on Al<sub>2</sub>O<sub>3</sub>.

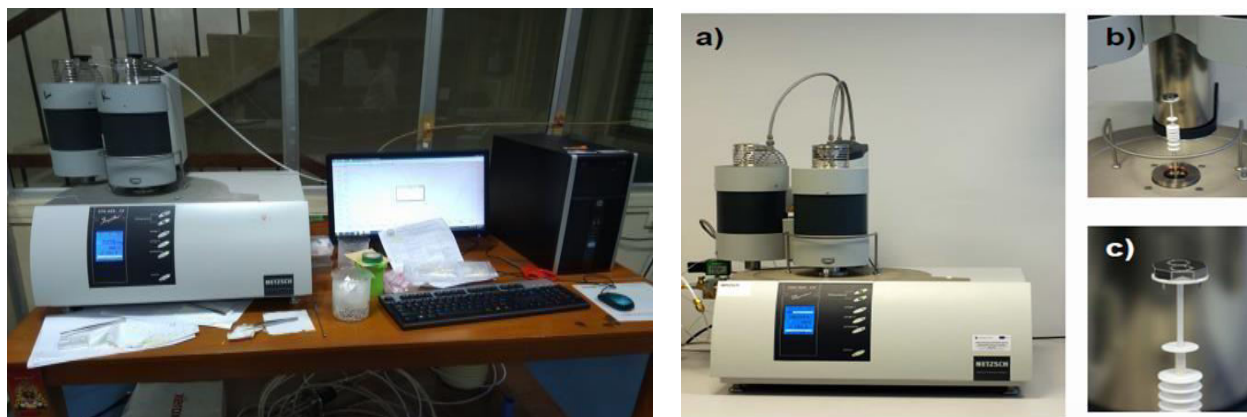

Fig: TG-DSC INSTRUMENT NETZSCH STA 449F3

The investigation of samples bioethanol, bio diesel, and its blends are exhibits one reaction zone, indicating that the apparatuses constituting the samples are similar in nature and the response interval zone is nearly identical for all samples. DSC combustion is performed using STA 449F3, an aluminum pan with a heating rate of 100C/min, and the curve is evaluated in terms of peak temperature, reaction intervals, and heat flow of the reactions. Some materials meet with partial combustion in air, forming char, which can affect results; however, in an oxygen environment, most organic materials will go through the entire combustion process, which is why the experiment is carried out in oxygen(O<sub>2</sub>). To run experiments on the DSC Analyzer, a test procedure must be specified. Depending on the experiment type, a temperature range of 25-600 C is used, with a constant heating rate of 5, 10, or 15 C/min. Also, nitrogen is chosen as the purge gas for pyrolysis experiments, while air is chosen for combustion experiments. Furthermore, some signals must be saved in order to analyses the experiment after it is completed. Time (min), temperature (C), heating flow (W/mg), sample purge gas, and flow rates (ml/min) were chosen as the signals.

## **3.Differential scanning calorimeter:**

Calorimeter measures the heat into or out of the sample. A differential calorimeter measures the heat of sample relative to a reference. Differential scanning calorimeter does all the above and heats the sample with a linear temperature. Endothermic means Heat flows into the sample. Exothermic means Heat flows out of the sample. DSc measures differences in the amount of heat required to increase the temperature of a sample and reference as a function of temperature.

Heat flow  $\propto C_p$  (Heat capacity of material for a given temperature).

**Enthalpy:** A thermodynamic quantity equivalent to the total heat content of system. It is equal to the internal energy of the system plus the product of pressure and volume.

#### **4. Results and Discussions:**

##### **Gasoline results:**

1)

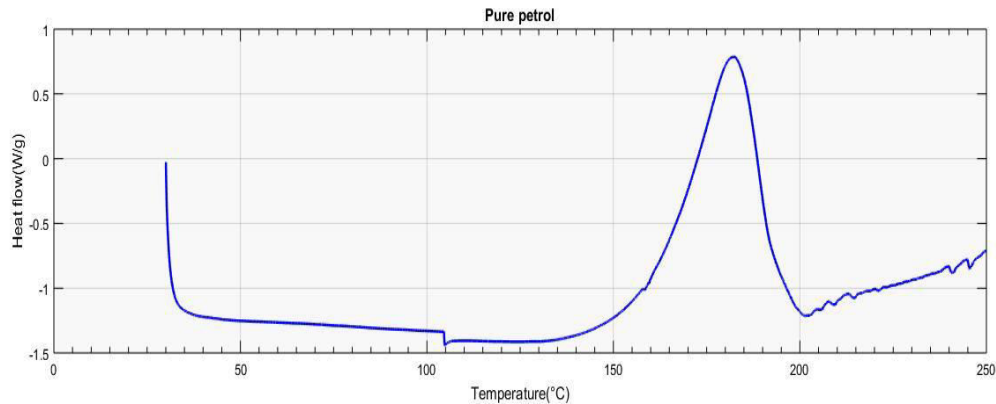

From the above figure Temp vs Heat Flow shows that the heating rate at 10c/min, the peak temperature of pure petrol is around 180°C. The DSC curve starts and remains constant at 40°C and drastically varies from 200°C from the temperature nearly 150°C to 180°C is endo-thermic reaction (+ve) reaction the DSC curve shifts to endo to exo thermic reaction from 180°C onwards the curve slightly comes to downward, and it is exothermic reaction.

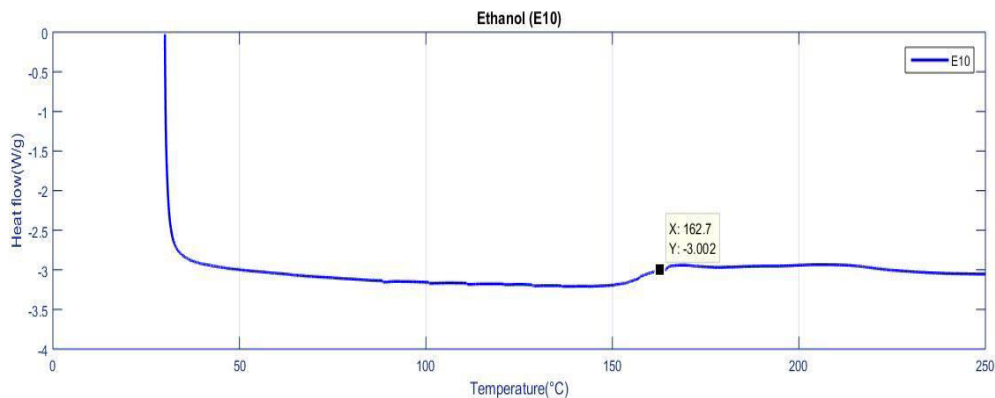

2)

From the above fig Temp vs Heat flow shows that the peak temperature take place is around 162°C, the DSC curve represents purely exo-thermic reaction compared to petrol it as high heating rate and boosting power and gave less emissions the curve starts at nearly 40°C and drastically varies through 250°C, therefore, the combustion becomes better by increasing the thermal efficiency.



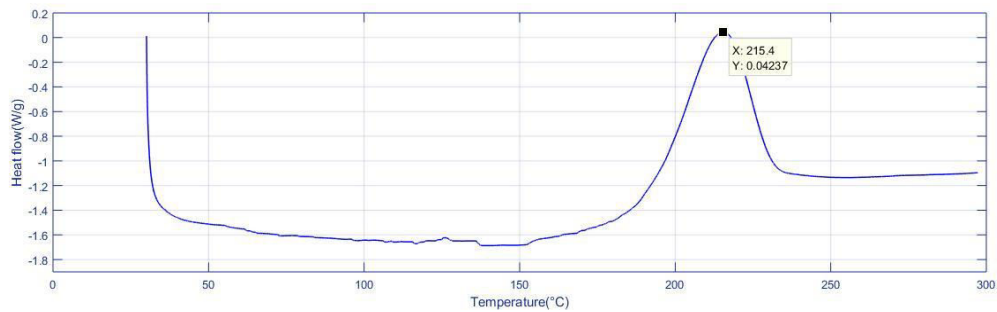

3)

From the above fig Temp vs Heat Flow, shows that the peak temperature take place is around 215°C, The DSC curve represents exothermic reaction (negative) take place, it can be constant at certain temperature of both exo-endo thermic reaction the curve starts at 35°C ends at 300°C nearly in between it E10 blend it has high octane number.\*During above analysis we say that we add the petrol into the ethanol it exhibits high octane rating and high thermal efficiency, low emissions, but the lifetime of engine should be reduced.

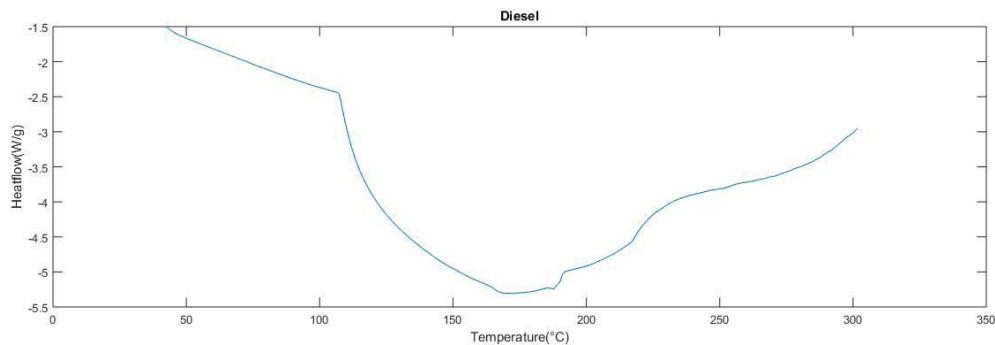

4)

From the above graph temp V Heat flow of diesel shows that the peak temperature is nearly 150°C to 180°C the DSC curve completely Exo-thermic and it is negative reaction take place the curve starts at nearly 50°C and ends at 250°C in between peak temp exhibits compare to petrol, the curve completely exothermic. In petrol it should changes the peak at certain temperature.

5)

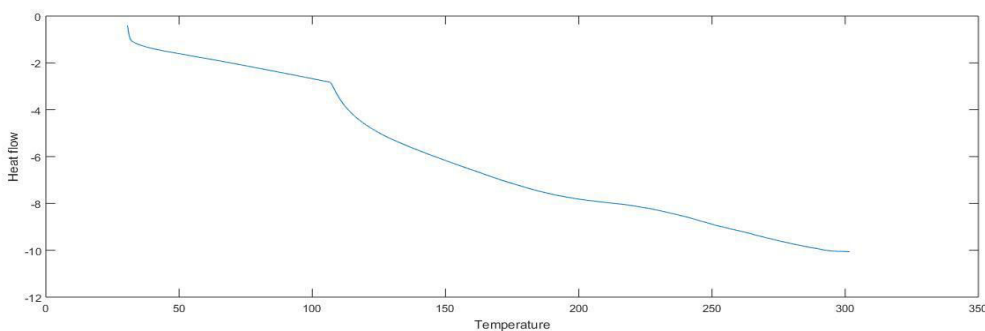

From the above graph temp vs Heat flow show that the peak temperature is nearly 100°C to 120°C the DSC curve downwards from the zero to negative it is completely exothermic reaction take place compare the diesel during the curve was at constant after 120°C is end point .100% of

jatropa oil is not used for combustion process, the heat flow or heat rate is constant at higher temperatures.

### **6)Waste cooking oil:**

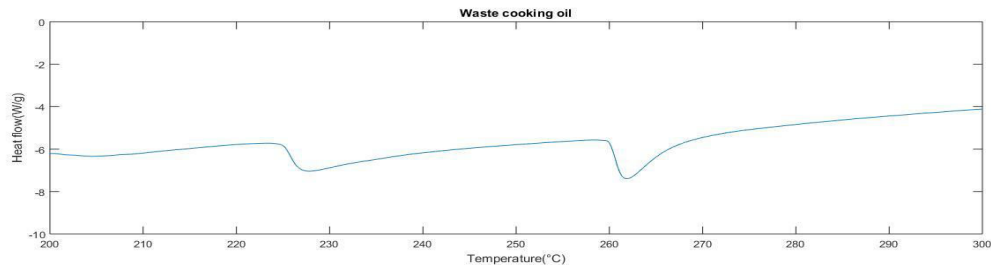

From the above graph temp vs heat flow shows that the peak temperatures exhibit two one is at 225°C and another one is at 265°C, at 265°C temp gets actual peak the DSC curve start at nearly 190°C and ends at 300°C here it was completely exothermic reaction (negative) take place compare the diesel it has high heat flow rate and high thermal efficiency etc.

### **7.Petrol enthalpy:**

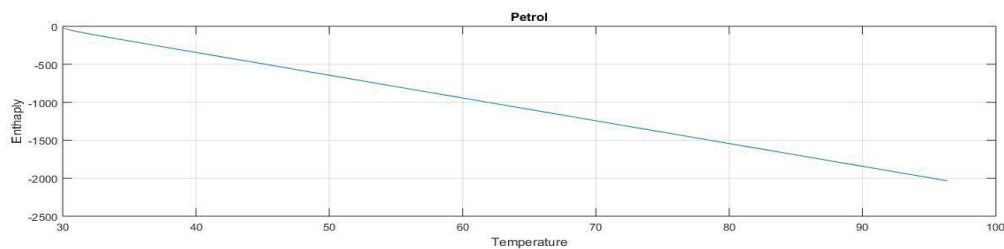

The above graph indicates that temp vs enthalpy of petrol w.k.t enthalpy is a function of temp, when the temp increases the enthalpy will be decreased, during the mass of fuel is corresponding to the temp increases than we calculate enthalpy change in reaction. Enthalpy reaction was completely exothermic reaction, and it should be negative. For enthalpy mainly products and reactants can be change it should be removed. The heat energy is given out when one mole of substance burns completely in oxygen.

### **8. Ethanol E10, E20:**

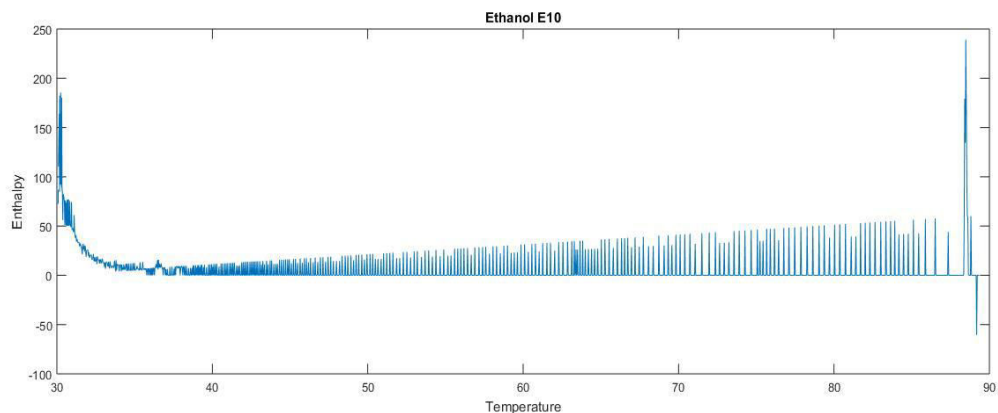

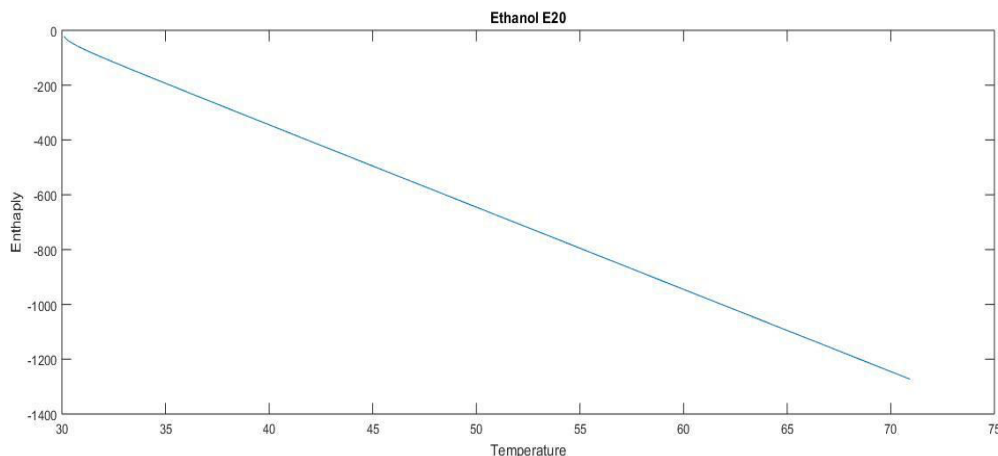

- From the above two graphs Ethanol E10, E20 temp vs enthalpy say that the temp increases enthalpy was decreases.
- For the ethanol boosting power is high and exhibits less emissions.
- In the Ethanol alcohol content is more when it is combines with petrol, the carbon and the oxygen content of air is easily taken and gave more heat to the combustion and gave less emissions.
- The bonds of C=O are double and stronger it should be giving enthalpy change. The products and reactants were more it gives actual enthalpy. Exothermic reaction (purely) and negative reaction formed.

### 9.Diesel enthalpy:

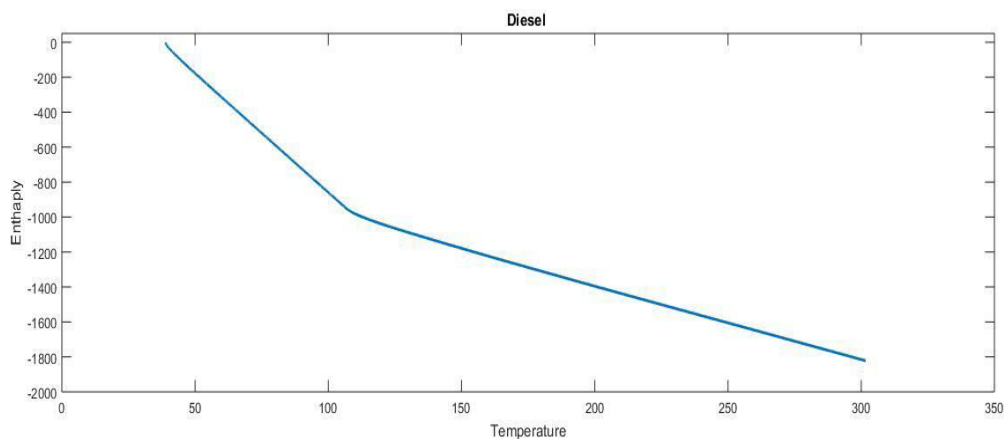

The above graph show that Temp vs enthalpy diesel is constant at 100°C after it can be changes it should be curved, the temperature increases the enthalpy was changes on its way. It is should exothermic reaction, negative reaction can be formed its means If ' $\Delta H$ ' is negative enthalpy of the system increases and the heat flow to the surroundings.

### 10. Waste cooking oil and jatropha oil:

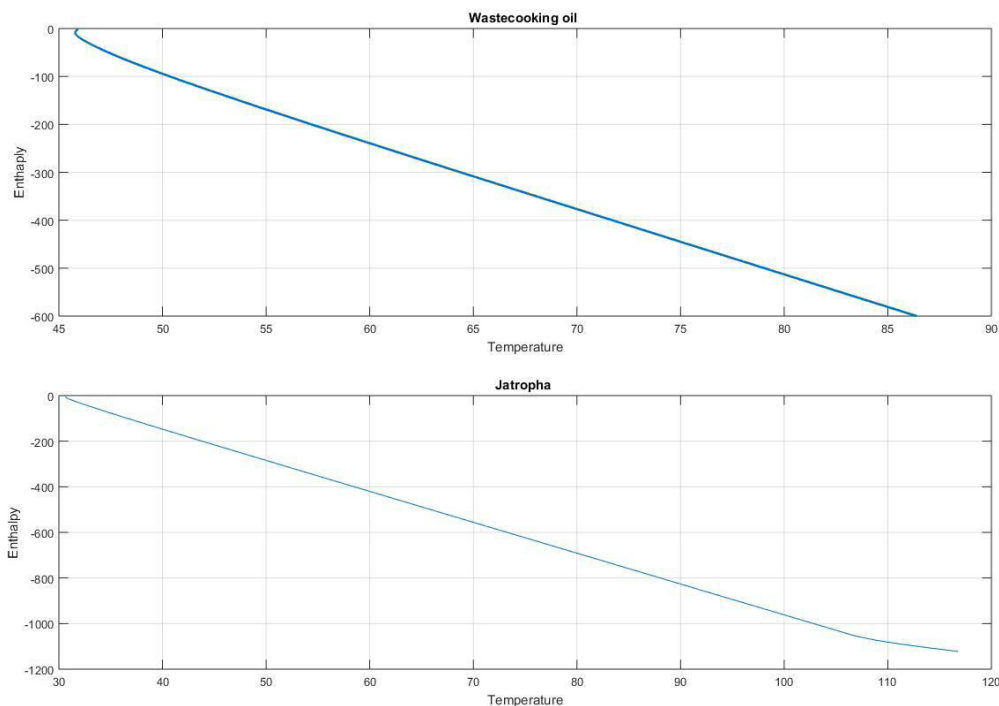

The above graph shows that the temp vs enthalpy of both waste cooking oil and jatropha oil, Temperature at starting to the ending 30°C to 120°C it should be constant and the enthalpy at 1000kJ it should be decreases gradually. The enthalpy change is exothermic reaction the reaction can be formed it means ' $\Delta H$ ' negative the enthalpy of the system increases and the heat flow to the surroundings. Pure waste cooking oil is heated at high temperatures. If the exothermic reaction, heat is released by the system to its surroundings. Bond making releases energy.

### 11. Petrol and its blends:

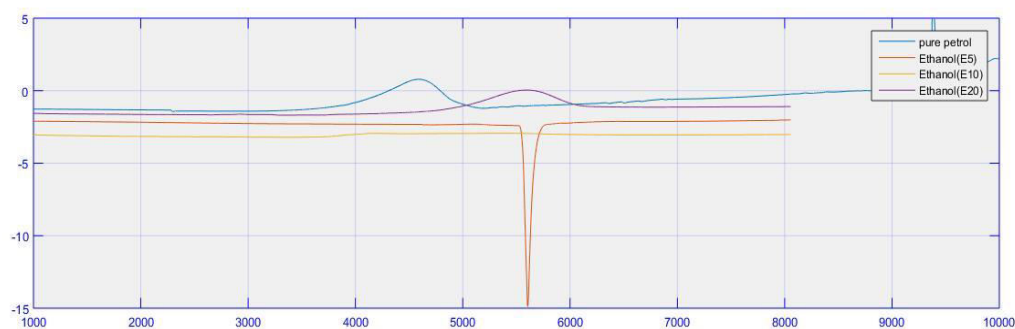

The above graph shows that all thermograms of Petrol and its Ethanol blends. The thermograms of petrol slightly the peak temperature goes to endothermic and afterwards down to exothermic reaction, the remaining Petrol-Ethanol blends are completely exo-thermic reaction the energy is released by the system.

- The Fire point of Ethanol blends are high compare to petrol.
- Heat of combustion is less than Petrol compare to Ethanol blends
- Ethanol blends octane number is increasing more compare to Petrol.

### 12.Diesel and various blends of seed oils:

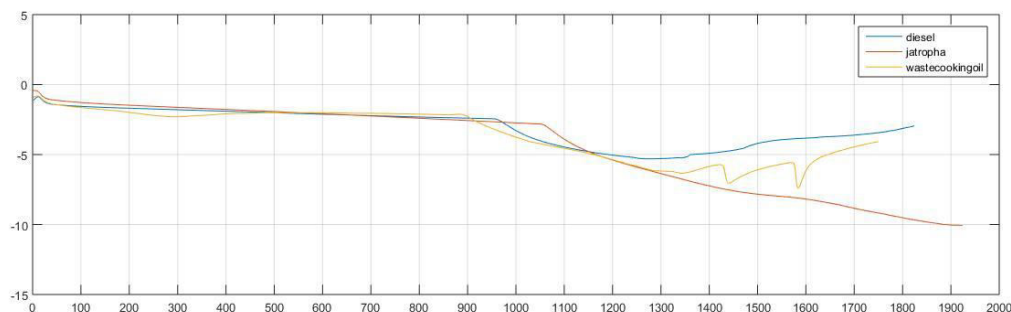

The above graph shows that all thermograms of Diesel and its Bio-diesel blends. The thermograms of waste cooking oil gives Exhaust peak compare to Diesel, Waste cooking oil and Jatropha all thermograms are exothermic reactions.1

- Calorific value of diesel is more compare to Jatropha and Waste cooking oil
- Jatropha seed oil and Waste cooking oil of Kinematic Viscosity is more than the Diesel.
- Jatropha seed oil and Waste cooking oil of Cetane number is increases more compare to Diesel.

Fuel blend	Density @15.6c	API gravity (deg)	Kinematic viscosity mm <sup>2</sup> /sec @30c	Flash point ©	Fire point ©	Cloud point ©	Head of combustion MJ/L	Octane number
Petrol	0.7400	59.53	0.4872	-	25.0	-22	34.84	93.2
E5	0.7385	58.42	0.4925	-	27	>8	34.12	95.2
E10	0.7396	57.10	0.5383	-	29.0	>8	33.19	97.1
E15	0.7495	57.09	0.5619	-	29.1	>8	32.91	98.6

**TABLE:1. FUEL PROPERTIES OF TESTED BLENDS OF PETROL**

Fuel blend	Density@15.6c	API gravity(deg)	Kinematic viscosity@40c	Calorific valve	Flashpoint	Cetane number
Diesel	0.82-0.87	39.51	1.3-4.1	42	60-80	40-55
Jatropha	0.91		3.598	38.65	229	23-41
Waste cooking oil	0.893	26.87	3.658	35.56	160	50

**TABLE:2. FUEL PROPERTIES OF VARIOUS OILS**

## **5. CONCLUSION:**

This Study has been conducted in order to search whether which alternative fuel as renewable energy source ,can be replaced by petrol and diesel fuel and also observe the effect of biodiesel & Ethanol blending on combustion at different percentages to petrol & diesel ,Therefore the Ethanol blending with petrol (E5,E10,E20) and diesel ,Jatropha oil & Waste cooking oil at different percentages are exposed at isothermal heating under nitrogen and air atmosphere with constant heating rate by using Differential Scanning Calorimetry ,Reaction parameters such as peak temperature ,heat flow of reaction, Enthalpy ,Specific heat capacity etc. are determined.

### **Petrol and its blends:**

- The peak temperature of petrol is exhibits at nearly 180°C
- Ethanol(E10) the peak temperature is nearly 162.7°C, and it is exothermic reaction
- Ethanol(E20) the peak temperature is nearly 215°C and is exothermic reaction, temperature is auto ignition temperature during combustion.

**During combustion**, the mixing of petrol into the ethanol blend it gives more accurate profiles. The E5 blend gets melting point from the curve accurately, the mixture E10 & E20 gets combustion reaction more efficiently. In DSC analysis at higher temperature interval implying the octane number of ethanol is higher than petrol and results in their no delay in petrol engines during combustion. Ethanol-gasoline blends used as alternative fuel for variable speed is spark-ignition up to 35% blends without engine modification. It concludes that the blending ethanol with petrol blends is economical with reduced harmful pollutions.

### **Diesel and its blends:**

- **The peak** temperature exhibits at nearly 170°C
- Jatropha seed oil the temperature exhibits at nearly 110°C it is exothermic reaction it means the energy is released by the system.
- Waste cooking oil the peak temperature is nearly 225°C and 265°C is exhibited it is also an exothermic reaction.

## **6. REFERENCES:**

1. Termicznej SAT'98 Materials Analysis Metodes Analizy Termicznej II, Materly konferenzjne (1998) 31-50 [L] Stoch Stoch Stoz:
2. V. Zielenkiewicz, II Szkoła Analizy SAT'98, Pomiary Effektów Ciepłych.Conferences (1998) 1-17. Conferences.
3. K. Rzyman Towarzyszące tworzeniu faz międzymetalicznych Efekty Energiczne Praca IMIM PAN, Kraków, Habilitacyjna (2002).
4. Candeia Friday: R. A. Souza J. C. O. M. A. F. C. M. Mr Santos Mr President Oh, I. M. G. Souza A. G. and L. E. B. (2007). Warm, rheological behaviour of biodiesel blends of fuel and methanol. Thermo gravimetric diary 87(3) 653-56. Thermal analysis diary.



5. Yu H. Lu C. and Han K. Niu S. Zhou Y. (2017). Examination of warm oleic corruption TG-FTIR is used to convert and manage the corrosive methyl and ethyl esters in the process.149(17923) 495-04. 494.
6. A. Watson: A chromium-nickel, chromium-nickel and silicone thermodynamic study, PhD theses of the University of Manchester University of Victoria (1987).
7. C. Client: Comparison of formation enthalpies and transitional mixing enthalpies Thermochemica Acta 314 (1998) 229-245 metal-based alloys.
8. A Javidialesaadi and S. Raeissi; High-Free Fatty Fatty Acid Content Biodiesel Production Oils: APCBEEEEProcesia 5(2013)474–478[4] Experimental investigation in the processing stage
9. Mr. Farooq, Anita Ramlib. Renewable energy 76 (2015) 362e368 Abdul Naeemc;
10. Zhang, Jincheng Ding, Zengdian Zhao, Bioresource Technology 123.
11. R.B. Sharma, Amit Pal, Juhi Sharaf, Biodiesel production from cooking oil waste, J. Eng. Res. Appl. 4(6) (2013)
12. Shahid E.M Shahid Shahid Shah A.N. Jamal, M. Munsha, M. N. Rumzan, M. Cooking oil Effect Used Compression inflammation engine methyl ester, J. Technol Quality. Management. 91–104 (II) (2012)
13. Joana Neiva Correia, Idalina Raposo, Joao Mendes, [3] Pedro Felizardo, M. Joao Moura Bordado, Berkemeier, Biodiesel production from the frying of garbageJ. 26(3) (2006) 487–494. Waste Management.
14. Cellulosic Material Bioethanol: biomass renewable engine fuel. PS. 2005;27:327–337. energy sources.
15. Lin Y, Tanaka S. Biomass resource fermentation ethanol: State and possibilities of today. Biotechnology Appl Microbiol. 2006;69:627-642. February.



**ACADEMICIA**  
**An International**  
**Multidisciplinary**  
**Research Journal**  
 (Double Blind Refereed & Peer Reviewed Journal)

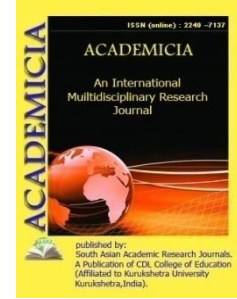

**DOI: 10.5958/2249-7137.2021.01905.4**

## THE THEME AND IDEA OF THE NOVEL “SHAYTANAT”

**Turdiyeva Yulduz Zayniddinqizi\***

\*Samarkand State University,  
 Samarkand, UZBEKISTAN

### ABSTRACT

*The article discusses the work of T. Malik in the detective genre in Uzbek literature, the novel "Shaytanat". The author aims to reveal the artistic idea of the work by describing the fate of its protagonists. The main task of the author, as the author himself points out, is to call people to awareness through topics, to encourage them not to repeat the mistakes they made. In writing The Devil, I tried to find answers to my problems. In expressing the theme of the work, the author focuses on the relationship between society and the individual and shows the special role of the environment in the development of the individual. During this period, people, even nations, became victims of the political game, the prey of bureaucrats and self-interested people. The oppression, discrimination, national pride and humiliation of the dictatorial regime have left an indelible and painful mark on the minds of the people. The events in Fergana, which left a bloody mark on the history of our country, turned into a massacre of compatriots for political purposes. The tragedy, which resulted in the loss of many lives, changed the lives of many more. The novel also depicts the fate of people who have forgotten themselves as wealth, career, and fame, and who do nothing for their own interests. But with this, I am far from concluding that all the protagonists in the play have negative characters.*

**KEYWORDS:** “Shaytanat”, Tahir Malik, Detective Genre, Crime World, Contradictions And Contradictions.

### INTRODUCTION

T. Malik's novel “Shaytanat” is a work in which his observations, thoughts, conclusions about the system that reigned in our country in the 80s, about the criminal world that arose directly under the influence of this regime, about life, destinies, contradictions and contradictions, the struggle of representatives of this world. This work is one of the first manifestations of the detective genre, in which the author revealed as much as possible the true picture of the social

environment of the era, the building of society and masterfully illuminated its place in the life and fate of people. I consider it necessary to note the following recognition of the outstanding thinker and literary critic Umarali Normatov: "in recent years, we have also revived the detective-adventure genre widespread in modern world literature, such talented and professional followers of this literary genre as Takhir Malik have grown up. The work of Tahir Malik "Shaytanat", which can compete with the best examples of world detective-adventure literature, has gained great popularity among the people "[1].

Indeed, until recently, there were practically no works related to the detective genre in Uzbek literature, it would not be an exaggeration to say that this work of Tahir Malik, created in this genre, ensured not only the success of the work but also the development of the genre.

### **MATERIALS AND METHODS**

The theme of the novel "Shaytanat" is not only the depiction of the vices and shortcomings of an ugly society but also the tragedy of those who have fallen into the streets of crime due to the injustices of the tyrannical regime, who have renounced their faith and humanity. The main task of the author, as the author himself points out, is to call people to awareness through topics, to encourage them not to repeat the mistakes they made. In writing *The Devil*, I tried to find answers to my problems. What is the role of a writer? Isn't it about observing society, analyzing it, participating in solving problems that arise? One of the pain points of the past was the criminal world. I've only had a fraction of that disease. People have seen or heard with their own eyes how ugly the underworld is. I've just compiled some of them and put them down on paper. My main purpose in writing these stories was to warn people: "People, look, don't be indifferent, there is an invisible world with you, but beware of it! Take special care of your children so that they do not become trapped in this world. There is only one door to this universe. You mean, like, saltines and their ilk, eh?" [2].

In expressing the theme of the work, the author focuses on the relationship between society and the individual and shows the special role of the environment in the development of the individual. As the literary critic, N. Karimov said: "Each period has its own problem, concept, position and image. It affects not only the individual, but also the society, and determines its direction. The successes and failures of this process, the political, enlightenment and spiritual views are inconceivable without the human heart, without suffering, without the spiritual world. It is natural that a change in human thinking is influenced by a change in time and society, which, in turn, determines the right direction of society, as well as its place and position in life. ... This means that it is not the events, but the person himself, his thoughts, pains, sufferings, psyche, spiritual world that are leading, describing, revealing" [3].

The fiction of recent years has rightly portrayed the contradictions between the individual and society, resulting in contradictions in human thinking. It should be noted that the role of the social environment in the formation of artistic character is invaluable. Tahir Malik also pays special attention to these aspects in revealing the theme of the play. No matter which protagonist is involved in this novel, you will witness the influence of the ruling system, social life, social environment on the formation of the character of this person, the perfection of the spiritual world. The author pays special attention to these places when creating the personal concept of the protagonists. Through his protagonists, the author finds himself in the "bitter" and "unjust" judgment of destiny, and in his heart, he feels an inexplicable hatred and revenge for the people

and the being that surrounds him. It is created by those who are devoted to extinction, who consider themselves the "innocent victims" of life, but who have forgotten that there are values in this world, such as goodness, truth, compassion, and conscience.

The novel also depicts the fate of people who have forgotten themselves as wealth, career, and fame, and who do nothing for their own interests. But with this, I am far from concluding that all the protagonists in the play have negative characters. The protagonists of the play are people who have gone through a difficult life, who have gone through various trials of fate. As you enter their worldview, psychology, lifestyle, and character, you get a glimpse of the world around them and the world they breathe. After all, the social environment plays an important role in the formation of personality. Tahir Malik pays special attention to this aspect, to this process, and in the play, he tries to vividly depict the painful and difficult points of the society that existed at that time. The author himself says: "I am determined to take advantage of the freedom of time and enter the dark streets of our lives. Don't be afraid to read what I've written and think it's dark. We see everything in broad daylight. We can't see in the dark. We hit, we push, we stumble. Don't we have to see the darkness to appreciate the light?" [4].

In fact, the play reflects the period when the freedom of our country was not in its will, both social and spiritual life in the country was disrupted, personal life and destiny were viewed superficially, and various dark forces ruled in society. During this period, people, even nations, became victims of the political game, the prey of bureaucrats and self-interested people. The oppression, discrimination, national pride and humiliation of the dictatorial regime have left an indelible and painful mark on the minds of the people. The lives of thousands of people have changed dramatically, and their lives have fallen into disrepair. The injustices of society, corruption, coercion, hypocrisy, greed, greed for wealth and careers have ruined many lives, filled their lives with darkness, ruined their futures and buried their dreams. It has caused people to resent, hate, and resent the current system. One mistake would start another. Some people took advantage of this situation in society and hid in the dark, ugly, narrow and closed streets of life and continued to fight for their goals and interests. Some won, some lost. Some people have a different mentality, a different worldview; the evil laws of survival were created. I would like to quote the author: "I want society to prosper without criminals. No one's child is born a criminal. No parent dreams of having a child when their child (or daughter) is a drug addict, but unfortunately, when they reach a certain age, some turn to crime. , they do not even know that they have entered the world of Shaytanat"[5].

That's the decent thing to do, and it should end there. It's about getting people on the edge of the abyss back in the right direction and not getting too close to the abyss. The events in Fergana, which left a bloody mark on the history of our country, turned into a massacre of compatriots for political purposes. The tragedy, which resulted in the loss of many lives, changed the lives of many more. It is in this environment, in the system, how can the character, psyche, the worldview of individuals grow up? Doesn't what is happening around you change people's minds? Isn't a person's philosophy, the path he chooses, the fate of the future determined by the social environment? Such questions can be answered by looking at Satan and observing the way of life and worldview of its protagonists. Tahir Malik skillfully uses the fate of the heroes Asadbek, Zahid, Elchin, Chuvrindi, Kesakpolvon, Anvar, Zaynab, Hosilboyvachcha, Hongrey to express the main idea of the work, to reveal the main theme.

The artistic idea of the work consists of several small ideas, which are in line with the theme of the work described above, ie, as the author noted above: “My main purpose in writing these events was to warn people:“ People, ko put on ribs, do not walk indifferently, there is an invisible world beside us with you, but beware of it yourself!Take special care of your children so that they do not become trapped in this world. There is only one door to this universe.You mean, like, saltines and their ilk, eh?

### CONCLUSION

In interpreting an artistic idea, the writer not only brings to the surface their atrocities, deeds and crimes but also shows the answers that these heroes could figure out with their actions, if I may say so punishment.After all, the main idea of the work is the realization that everyone should be adequately responsible for their sins, that, as noted above, “for those who entered the underworld, it is clearer to leave without the shroud”.In particular, while the main characters of Asadbek's work were responsible for their sins with the honour and happiness of his daughter and the life of his son, Chuvrindi, Kesakpolvon, Hosilboyvaccha, Hongri and others responded with their lives, finding a sad death.It is in this way that the writer sets himself the goal of revealing the artistic idea of the work, depicting the fate of his heroes in the work.

### REFERENCES

1. Hopматов У. (2000). Hopeful. Tashkent. Spirituality.
2. Kurban Sh. (2008). Lessons from Tahir Malik: Thoughts on the personality of a writer. Tashkent. Davr Press.
3. H. Karimov. (2010). Independence period literature. Textbook. Tashkent, New Publishing House.
4. Tohir Malik. (2011). Shaytanat. Roman. Beshinchi kitob. Toshkent, *Sharq*.
5. Kholikov, B. A. (2020). Principles of development of detective literature. *Bulletin of Gulistan State University*, 2020(3), 29-35.



**ACADEMICIA**  
**An International**  
**Multidisciplinary**  
**Research Journal**  
 (Double Blind Refereed & Peer Reviewed Journal)

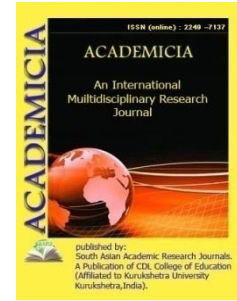

**DOI: 10.5958/2249-7137.2021.01906.6**

## THE PROFESSIONAL PEDAGOGICAL ACTIVITY IN MODERN EDUCATION

**Tursumatova Shaxlo Samievna\***; **Raxmonova Malohat Mirkomilovna\***;  
**Khomidov Vohidjon Obidovich\***

\*Assistant,  
 Department of Light Industry Technologies and Equipment,  
 Fergana Polytechnic Institute, Fergana, UZBEKISTAN

### ABSTRACT

*The essence and structure of pedagogical activity, as well as the effectiveness associated with them, is one of the most pressing issues of pedagogical science and practice. Typically, the scientific analysis of these important events is replaced by general discussions about pedagogical art. This article discusses the skills and activities of professional teachers in modern education, as well as the role of higher education in the training of qualified personnel. The reasons for many unsuccessful attempts to improve pedagogical systems and changing its elements are related to a local approach, not a systemic one. The society that forms the social order builds an appropriate education system as the most general pedagogical system. The reasons for many unsuccessful attempts to improve pedagogical systems and changing its elements are related to a local approach, not a systemic one. The society that forms the social order builds an appropriate education system as the most general pedagogical system.*

**KEYWORDS:** Skills, Modern Education, Professional, Staff, Educator

### INTRODUCTION

Today, the modern educational process is to prepare the younger generation for life based on a social order that reflects the needs of society. In the process of education and upbringing, young people acquire knowledge, manners, customs, culture and labour skills accumulated by their ancestors, take their rightful place in society on the basis of life experience, pedagogical personality in the formation of potential and worldview, activities and his professional skills are important [1]. At the same time, the formation of the qualities necessary for young people to solve new problems and challenges arising from the demands of the times is a priority in the field of pedagogical activity. To do this, the educator must first have the skills to impart new



knowledge, to engage in creative activities in response to changing working and living conditions [2].

## **MATERIALS AND METHODS**

Of course, the scientific analysis of pedagogical activity emphasizes the uniqueness of each teacher's creative method, but it is based not on descriptions, but on the principles of comparative research, qualitative and quantitative analysis. It is considered as a promising direction related to the application of the principles of a systematic approach in the analysis and development of models of pedagogical activity. As an artificially organized, organized, pedagogical system specially organized by the objective laws of social development, that is, under the constant "control" of society. The social system that is part of it. Changes in the pedagogical system, its structural structure and adaptation now depend on what or what elements the impact of society is focused on: strengthening the material base, improving the content of education, caring for the material condition of the teacher and others. The reasons for many unsuccessful attempts to improve pedagogical systems and changing its elements are related to a local approach, not a systemic one. The society that forms the social order builds an appropriate education system as the most general pedagogical system. This, in turn, has all the social institutions that perform the functions of education with their subsystems and are integrated into the education system. For the effective functioning of pedagogical systems aimed at educating the younger generation, society will create a system of training for teachers, secondary special and higher education institutions [3,4].

Spiritual foundations of economic reforms, liberalization of the economy, the specifics of a market economy, demography and economic policy, intellectual property and its assessment, the family budget and its economic basis, the social significance of the insurance and tax system, economic development in Uzbekistan. Achieving mutually beneficial economic relations with the world on the path of renewal, development and progress, the formation of a sense of ownership in young people, the causes of the global financial and economic crisis and its elimination, ways to modernize production, natural and human resources it is required to be able to form economic knowledge, skills and competencies related to rational use.

Today, professional teachers need to have professional training and experience, self-awareness, confidence in their own strengths and knowledge, thorough knowledge of their profession, and the ability to demonstrate the qualities that define such professional maturity. In addition, it is becoming a modern requirement for a professional teacher to work independently, learn best practices, innovations in the system and apply them in their work. As the head of our state said in his address to the Oliy Majlis, today people's minds must change, we have no right to live and work as we do today. In times of crisis, our knowledge and experience today will become obsolete tomorrow. If a teacher does not change his mind today, he will become an unnecessary person in the community if he lags behind in updating. Who wants to learn from a backward teacher? Of course, in today's rapidly changing world, professional teachers need to know pedagogical methods such as logical thinking, research, calculation, measurement, construction, testing, observation, comparison, inference, independent decision-making. Changes, radical reforms in the socio-economic life of our country, a good knowledge of the essence of political processes, awareness of foreign policy, in short, a high level of ideology and ideology are required.

In modern education, professional teachers do not know what and how to use communicative information, self-development, socially active citizenship, national and cultural, mathematical literacy, science and technology innovations, and how to use them. A teacher today cannot help improve the quality of education. What pedagogical methods should be used to develop such competencies in the classroom should be known not only by the teacher but also in practice. After all, if such competencies are not formed in the teacher himself, how can he form them in his students? Today, raising the content of higher education to a qualitatively new level depends on the training of highly qualified personnel who will be able to find their place in the labour market, making a worthy contribution to the sustainable development of the social sphere and economic sectors. Therefore, a professional teacher has a great responsibility, such as ideological and political training of young people, assistance in the acquisition of nature, society, profession. In today's fast-paced world, the criteria for a teacher's comprehensive maturity require that he or she know more than one foreign language in addition to his or her native language. Because today all the innovative methods, various technologies are used based on the experience of developed European countries. Therefore, in the organization of modern education, the teacher's high level of knowledge of foreign languages (especially Russian and English) is an important criterion for the ability to use modern advanced methods.

### CONCLUSION

In short, today's requirements are completely different from yesterday's. Of course, the higher the quality of higher education, the stronger the human resources. Therefore, there is a growing need to train personnel who think modern, keep pace with the latest news, and enrich their worldview day by day. In this process, higher education teachers have a great responsibility. Therefore, a professional must constantly improve their skills.

### REFERENCES

1. Saidakhmedov. N. (1998). The driving force in education. Enlightenment.
2. Farberman. B.L. (2002). Modern methods of teaching in higher education. Tashkent.
3. Djuraeva, D. D., & Berdiyeva, Z. M. (2016). Cultural heritage as a factor of human development (on the example of Uzbekistan). *Ученый XXI века*, 23.
4. Sergeeva, M. G., Shumeyko, A. A., Serebrennikova, A. V., Denisov, A. N., Bondarenko, N. G., & Getmanova, E. S. (2018). Innovative pedagogical experience in the practice of modern education modernization. *Research Journal of Pharmaceutical, Biological and Chemical Sciences*, 9, 1049-1055.

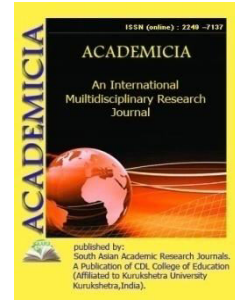
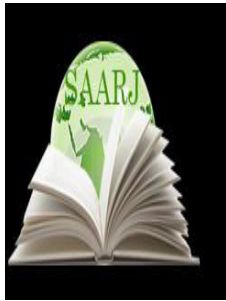

DOI: [10.5958/2249-7137.2021.01907.8](https://doi.org/10.5958/2249-7137.2021.01907.8)

## METHODOLOGICAL FEATURES OF "HISTORICAL PROPERTY AJAM"

Qodirjon Ergashev\*

\*Institute of Uzbek Language,  
Literature and folklore of the Academy,  
Sciences of the Republic of UZBEKISTAN

### ABSTRACT

*Research shows that "Tarihi muluki Ajam" was written as part of a larger work, or rather as an introduction. It is this fact and the author's goal to convey historical knowledge to the Turkish public in a simple, concise, understandable way that has made this work unique in terms of style, creating a new style that differs from the traditional style of historical prose written in Persian. It is known that medieval writers also adorned historical prose with fine arts, demonstrating their eloquence and prose skills, and ending with eloquence and maturity. Of course, on the one hand, this is a positive thing, it brings historical prose closer to fiction, allows us to look at examples of historical prose as a kind of literary work, prose, artistic creation. But, on the other hand, the authors' excessive efforts to "express themselves" and their exaggeration have led to the complication of the style, the formation of a silent, lofty language and style that is incomprehensible to many. The works of Mirkhand and Khandamir, and a number of historians who preceded them, were written in the same style.*

**KEYWORDS:** *Historical property Ajam, Hormuz binni Nasri, Yazdijurd binni Bahrom, Chun's father, "Jome' ut-tavorihi Jalaliy", "Devon un-nasab", "Zafarnoma".*

### INTRODUCTION

Alisher Navoi did not follow this path with his own innovation and invented a new style for himself. A. Hayitmetov was selected and registered. "The style of writing of the historical property of the novice," the scholar writes, "is undoubtedly fundamentally different from the style of many history books. It is known that several historians lived in the second half of the 15th century. When Mirkhand, one of the most famous of them, began to write Ravzat us-safo, Navoi told him: But Mirkhand writes not in the way that Navoi said, but in the traditional, luxurious style of his predecessors ... "

Noting that Navoi implemented the above idea in writing "Tarihi muluki Ajam" and, although in many respects faithful to the existing historiographical traditions, acted independently on the issue of style, A. Hayitmetov also points out some features of the style of work: "We in his work difficult, complex, meaningless, high-flying expressions and figurative elements, we almost do not see abstract sentences. He tries to express his thoughts as simply as possible, because, in his opinion, a history book tells the story of great historical facts, and such a book should be easy to understand for any reader or listener, whether he is a scientist or a farmer. S. Ganieva also notes that in "Tarihi muluki Ajam" the author pays attention to the methodological simplicity of his work.

It is noteworthy that the scholar recognized the style of "Tarihi muluki Ajam" as a new style and noted that it is of great importance in the study of Navoi's style. also created the style .... This work ... is still very important in examining Navoi's unique style. ”

Our research shows that the main aspect of the method "Historical property of the novice" is reflected in the presence and synthesis of two elements - scientific and literary methods. This is not in vain explained by the presence in the structure of the work of two closely spaced layers. These are scientific and literary strata, the scientific stratum of historical data, facts, historical events and happenings in "Tarihi muluki Ajam", their artistic description, mythical-romantic interpretation of the literary stratum.

In "Tarihi muluki Ajam" the peculiarities of the scientific style are reflected in the following:

1. Systematization of historical data and knowledge and its systematic (systematic) presentation to the reader. It is known that the systematization of data and knowledge can be done in different ways. Navoi chooses the dynastic principle and systematizes the data and facts on this basis. In the play, information about the history of the novice is divided into four parts according to the four dynasties that ruled at that time. Each section in turn consists of sections devoted to the representatives of the dynasties. In this case, the representatives of the dynasty are mentioned in the order corresponding to the years of their rule, that is, along with the dynastic principle, the chronological principle also applies.

2. Accuracy and clarity of statement. The scientific method requires precision and clarity. Navoi understood this well. This is evidenced by his words to the historian Mirkhand that the style of the history book is simple, the phrases are free from metaphors, allegories, satire and other complexities, and can be understood by everyone. The best way to achieve clarity and clarity is simplicity. For this reason, the author almost does not use the combined method of composing text in "Tarihi muluki Ajam", refraining from the use of complex artistic means and art. We see in the text of the work that when this or that ruler is described or evaluated in his activity, he uses clear, at the same time simple and concise adjectives: wise, just, cruel, jealous, skeptical, wise, ignorant and so on. For example, about Shapur bin Ardasher: "And he was a wise and just king"; About Bahram bin Hormuz: "And this Bahram was a pious man and a wise king"; About Faridun: "He was a good man, a scholar and a just king"; About Hurmuz bin Nasri: "He was a very pious and pious man"; About Yazdijurd bin Bahram: "... he was a tyrant and a fool."

The author strives for clarity, clarity not only in the description of the rulers, but also in the description of the historical events associated with them, and this is reflected in the composition of the text. This is evidenced by the fact that the text often consists of short, concise sentences

and sentences, each of which contains a specific piece of information, information or fact, and this can be seen in the following passage from the mention of Shapur bin Ardasher:

“Chun ascended the throne in place of his father, did not change his father's image and law, and did not deprive the people he appointed of their provinces and positions. And he was a wise and just king. And they complained to him that in Constantinople the Roman emperor had gone too far. Shopur Nisibin was able to lay siege to the city and dispose of Caesar's treasure. Caesar, knowing his limits, used the Shafi'is as a vehicle and accepted the tribute. The driver returned victorious and victorious. And his masterpiece was Nishapur in Khorasan, built by Ani Tahmuras. But Shopur made it better with a new head of chess. ”

3. Consistency of statement. In "Tarihi muluki Ajam" Navoi strictly follows the sequence of historical information. Each part of the work appears as an integral continuation of the previous parts, both chronologically and in terms of content. The author does not go beyond the events. There are also almost no cases of stopping the statement of certain thoughts or events at one point, moving on to others, and then returning to previous events.

Consistency is also maintained in the internal structure of the text. In this case, each sentence, phrase and its content are related to the previous ones, serve to continue, supplement and develop the idea in them, and form a link in the chain of narration, advancing the statement.

4. Substantiation and substantiation of opinions, confirmation of information and facts. These features of scientific works and scientific style are also present in "Tarihi muluki Ajam". Navoi refers to a number of sources in order to substantiate the information he provides and the views he expresses. “Nizam ut-Tawarikh”, “Jame't-Tawarikh of Jalaliy”, “History of Tabari”, “Jame't-Tawarikh of Banokatiy”, “Muntahob ut-Tawarikh”, “Devon un-Nasab”, “History of Hamidullah Al-Mustafavi” Ghazali's Nasihat ul-muluk, Sharafuddin Ali Yazdi's Zafarnoma, Qazi Bayzawi's historical work, Mirkhand's works are among them.

In addition, Navoi drew attention to the aspects of literary works - epics related to historical figures and events, and in his book, along with pure historical sources, he referred to them.

5. The presence of an analytical and critical spirit. Analysis and criticism are key components of the scientific method. Navoi's critical approach to sources can be seen in the following poem in his History of the Prophet and the Ruler:

There is a lot of controversy in history,  
The Shahnameh has a lot to say,  
There are many unfortunate hand ghazals,  
You have a lot of points.

An analysis of the "Historical Property of Ajam" shows that Navoi's views in the above poem are not just words. In many parts of the work, Navoi expresses his attitude to historical sources and the information contained in them, analyzes them and criticizes them in some places. For example, in the mention of Girshosb, the last representative of the Peshdadis, he disbelieved the information given by the authors of historical works that Rustami was a descendant of Girshosb, and wrote: But in the eyes of the poor, this verse is more distant, because Zolkim is Rustam's father, he had sipohsols in his eyes, and they brought Girshosb to Manuchehr's grandson in



Guzida and in many tawarikhs, and Rustam was called Sam ibn Nariman bin Atrub bin al-Ablamun.

In Doro's dhikr, Navoi cites two versions of his death, saying, "The former is more authentic," and the former is more plausible.

In the Ashkani section of the work, he criticizes Hamidullah Mustafavi's "History in the Guzida" and writes: It is as if this is strange, the property of the Alars is Tawheed, because I have killed myself, some of the Tawheed have been killed by Ashk bin Dari, and the Ashkenazis are called the descendants of Ashk bin Dari. ”

Myths and legends in "Tarihi muluki Ajam", the legendary-romantic analysis of historical events form the literary plate of the work. It should be noted at this point that romantic interpretations do not distort the essence of historical reality, data and facts in the play. No matter how artistically the author describes historical events, the historical basis is preserved. For example, in the dhikr of Ardasher Babak, it is a historical fact that Ardasher Babak fought against Arduvan, the last representative of the Ashkanids, defeated him, seized power and founded a new Sassanid dynasty, and it is reflected in the "Historical Property of Ajam".

In fictionalizing the story, Navoi uses romantic-style tools and motifs, including an adventurous-romantic spirit and colorful love motif in Ardasher-related films, a mystery (the minister secretly raises the girl after she gives birth to a child without killing her, and tells Arduvan the truth when the opportunity arises). revealing the secret), coincidence (Ardasher accidentally fantasizes about getting a bottle of juice and thus saves his life) effects. In several scenes in "Tarihi muluki Ajam" the motive of love serves to save the life of the hero, to save him from a difficult situation. We have seen above that one of them, King Arduvan, tried to assassinate Ardasher Bobak, and the concubine, who had fallen in love with Ardasher, warned him of this, and they escaped together. Another inscription on this motif is found in the dhikr of King Shopuri Zulaktof of the Sassanid dynasty. The driver goes to Rome in the guise of an ordinary man without revealing his identity. But there they recognize Shopur. The Roman emperor captures him, holds him captive, and marches into Shopur's country with an army. Caesar sees Shopur, the daughter of the man who appointed him to guard Shopur, falls in love with him and saves him from captivity. They flee and come to Qazvin together. Navoi writes about this: The daughter of the man who kept the driver in love fell in love with him, and he escaped from captivity.

The main feature of the method "Historical property of the novice" - the formation of a synthesis of scientific and artistic methods, as well as the motive of adventure and spectacle play a role in the mythical-romantic interpretation of historical events and happenings. The fact that Shopur changed his appearance and went to Rome in the above scene is to some extent related to this motive.

This motif also plays an important role in the part of the work dedicated to the dhikr of Bahrom bin Yazdijurd (Bahrom's grave). In this section, the author narrates, among other events related to Bahrom, his visit to India and his adventures there. Navoi describes these events as "strangely hopeful" (one of the strange things - Q.E.): According to Navoi's writings, there was no serious reason for Bahrom to go to India, only the desire for adventure, the desire to see another country, to see it, motivated him to this trip. Navoi's following words clearly show this: And one of the alardins, when he heard the ajubas of the Indian property, envied it and handed it over to Narcissus, secretly escaped and went to India. ”



The romantic motives and interpretations, as well as the artistic description of the events, allow us to look at a number of rulers mentioned in "Tarihi mulukiAjam" not only as historical figures, but also as literary characters. Among them are those whose images have been completed, various aspects of their personality have been revealed, and they have risen to the level of an artistic image. Here is another peculiarity of Navoi's style: it emphasizes one or two main features of the characters, which distinguish them from others, other qualities and shortcomings of these people, various other aspects of personality against the background of these leading features, during the events associated with them. opens.

This can be seen in the example of Khusrav Parviz and Bahromgor. In the story of Khusrav, Navoi points to the authoritarianism and tyranny of his nature as key features. Khusraw's tyranny is described in the Tarihi Muluki Ajam as follows: I imprisoned twenty thousand of my own people, al-uhdatu al-ar-ravi, of whom a thousand were honorable and great men. Every day I would order them to sit in a cricket because they didn't do well. " According to the interpretation in the work, it was these aspects of his character that led to the collapse of the state of Khisrav Parviz and his assassination.

In the section dedicated to Bahromgor, Navoi emphasizes and describes the hunger for pleasure, spectacle and adventure in the nature of Bahrom. Both the events narrated in Bahram's dhikr and the events that befell Bahrom are related to these very features of his nature. As a result of Bahrom's indulgence, there will be a collapse in the affairs of the state, the power will be weakened, and the country will be ruined. The situation is such that when the enemy attacks his property, Bahrom cannot find the strength to resist him. The Turkish khan easily invaded the country. A number of other aspects of Bahrom's personality are revealed during the post-invasion events. Assessing the situation correctly, Bahrom, realizing that the resistance was futile, withdrew himself and left the country with a few loyal men. After that, he patiently waits for the right moment, and when such an opportunity arises, he suddenly attacks and wins. Here, due to the changes in Bahrom's personality that took place after the invasion of the Turkish Hakan, he appears in the eyes of the reader as a dynamic image, not a static one.

The fact that such a dynamic image is found in other parts of the "Historical Property of Ajam" allows us to consider it as one of the peculiarities of the Navoi style of painting.

## REFERENCES

1. Hayitmetov. "History of Ajam's property". Uzbek historical literature. Volume 5, Volume 2, page 448. Tashkent, "Fan" 1977.
2. S. Ganieva. Prose works of Alisher Navoi. Tashkent, Uzbekistan, 1981. p.
3. K. Ergeshev. Historical truth and mythical-romantic interpretation in "History of Ajam's property". ЎТА, 2006, No. 5, pp. 21-25.
4. K. Ergashev. "There is a lot of disagreement among the people of history." AZAS, May 18, 2001.
5. Alisher Navoi. "Historical property Ajam" 10 years, 8 years. Tashkent, 2011. Pages 623-624.
6. Alisher Navoi. "History of Prophets and Judges" for 10 years and 8 years. Tashkent, 2011, p.542

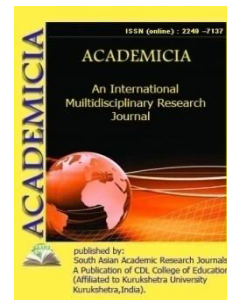
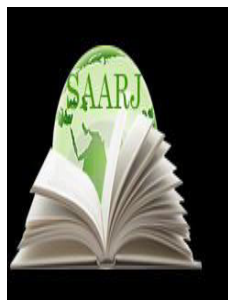

DOI: **10.5958/2249-7137.2021.01908.X**

## DEVELOPMENT OF CREATIVE ABILITY OF FUTURE TEACHERS ON THE BASIS OF ACMEOLOGICAL APPROACH

**Muminova Gulnozaxon Sultan qizi\***

\*Independent Researcher,  
TDPU named after Nizami,  
UZBEKISTAN  
Email id: gulnoz\_1809@mail.ru

### ABSTRACT

*The first condition in the organization of pedagogical activity, that is, a real pedagogical orientation, acquires a positive character and contributes to the acquisition of an acmeological level in pedagogical activity. Only the first pedagogical training in the organization of pedagogical activity helps to achieve high results. The main motive of a real pedagogical orientation is the interest in pedagogical activity. This article discusses the development of creative skills of future teachers based on the acmeological approach. Creativity is the activity of a person and its outcome that determines the importance and usefulness of a particular innovation. A creative person is a person who is able to successfully carry out the creative process and has clear creative results. One of the most important tasks of higher education institutions is to form the professional training of future professionals. Vocational training is interpreted as a specific manifestation of a person's social competence, which is based on the acquisition of the necessary professional knowledge, skills and competencies. It is usually advisable to approach prospective teachers in terms of their objective capabilities, to identify the capabilities of the individual to the requirements of the chosen profession and activity.*

**KEYWORDS:** *Pedagogical Activity; Creativity; Acmeological Approach; Professionalism.*

### INTRODUCTION

It is well known that the acmeological approach reveals the individual features of education. Its essence is that education moves from the imaginary world of the individual to the meaningful real life of the educator and the student. Education based on this approach not only changes the mindset and attitudes of the educator and the child, but also leads to the formation and

development of the subject of interaction. The acmeological approach to education serves to transform self-education, self-learning, that is, into an environment of collaboration and co-creation. In this process, the real-life position of the educator and the child in the context of education is important to bring education to an ideal form. This approach focuses on achieving the end result of education - the universalization of the educator and the child and the fulfillment of the practical function. The creative aspect of acmeology is to determine the validity of the effort expended by explaining the professionalism, its reflexive-innovative potential, which rises to the level of mastery, and the social significance gained in the creative process. After all, one of the most pressing issues is to raise the general state program in the field of education to a new level and enrich it with new content, to acquire modern knowledge, to have the necessary skills in life and employment. and in the timely recognition, education and realization of the unique abilities and talents of each age group, it is especially important to regularly engage in the deep acquisition of professional culture, etiquette, creativity and experience of maturity.

Pedagogical creativity is the ability of a teacher to create new ideas that serve to ensure the effectiveness of the educational process, as opposed to traditional pedagogical thinking, as well as to describe the readiness to positively address existing pedagogical problems. Creativity is the activity of a person and its outcome that determines the importance and usefulness of a particular innovation. A creative person is a person who is able to successfully carry out the creative process and has clear creative results. Also, a creative person is a person who demonstrates creativity as a process or result, tends to approach problems in a non-standard way, is able and ready to organize original actions, promote innovation, create creative products.

One of the most important tasks of higher education institutions is to form the professional training of future professionals. Vocational training is interpreted as a specific manifestation of a person's social competence, which is based on the acquisition of the necessary professional knowledge, skills and competencies. Vocational training does not happen by itself, but involves specific stages that are planned based on specific goals. The formation of professional training in a person is initially determined by the composition of the professional vision, concepts, and then explained by the acquisition of knowledge, skills and abilities in the specialty, the determination of professional qualities and the degree of professional adaptation. Vocational adaptation is the level of professional competence of the future specialist in the conditions of objective and subjective education, mastering the requirements of future professional activity, adaptation to the process of activity.

Professional opportunities reflect the objective conditions of a particular activity related to the will of the individual. It is usually advisable to approach prospective teachers in terms of their objective capabilities, to identify the capabilities of the individual to the requirements of the chosen profession and activity. For example, when choosing a teaching profession, not only love of the profession, the desire to communicate with children, but also the fact that the physical, psychological and social requirements of the profession to the individual are within its capabilities to acquire professional knowledge, skills and abilities. Helps Therefore, in the professional adaptation of future teachers, special attention should be paid to the theoretical substantiation of these aspects of the issue and the development of professional opportunities of future professionals.

**REFERENCES**

1. Azizxodjaeva N.N. Technology of teacher training. - T .: 2000.
2. Arzikulov D. Improving professional skills through psychological and pedagogical training. T .: 2002.
3. Boymuradova G. The role of interaction in the formation of professional and personal qualities of teachers. T .: 2008.
4. Yuldashev J.G ', Usmonov S.A. Implementation of modern pedagogical technologies / A guide for teachers of advanced training courses on theoretical and practical knowledge of advanced pedagogical technologies. Editor-in-Chief: S. Hasanov. - T .: 2008.

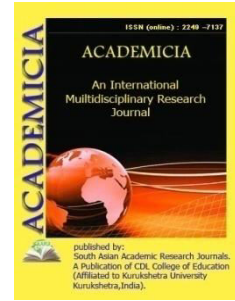

DOI: **10.5958/2249-7137.2021.01909.1**

## THE CAUSES OF FORBIDDEN RELIGIOUS EXTREMIST GROUPS

**Sobirov Utkir Tursunboy Ogli\***

\*Researcher of the International Islamic Academy of Uzbekistan,  
Chief Specialist of the Muslim Board of UZBEKISTAN  
Email id: sobirov.utkirbek@inbox.ru

### ABSTRACT

*This article talks about the psychology of a religiously fanatical personality, its portrait and the factors that characterize it. At the same time, in the article the author tries to analyze the spiritual world, the behavior of a person of this type, its inherent features, as well as a number of factors that affect the fact that a person becomes fanatical.*

**KEYWORDS:** *Psychology, Radicalism, Religious Fanaticism, Personality, Individuality, Character, Temperament, Peculiarity, Psyche, Ideas, Ideology, Religious Prevention, Psychopath.*

### INTRODUCTION

At a time when all conditions are being created for freedom of religion, several terrorist organizations and banned extremist groups under the guise of extremism and radicalism are still trying to spread out the destructive ideas among the people in various ways in order to carry out their nefarious plans.

It should be noted that most religious extremist groups and sects hide the extremist direction in their activities under the guise of religion. The infiltration of a person who does not have a religious view and understanding and the perception of “extraordinary new information”, affects his subconscious. As a result, the psyche of this person is completely controlled by the members of the group. Namely, a person gradually moves away from reality and begins to submit to the norms that are accepted as correct only in this group.

**We consider the following factors as contributing to the influence of a banned religious extremist group:**

#### 1. Social factors:

- ❖ low religious literacy, need for social protection;
- ❖ humiliated and in need of moral protection;
- ❖ inability to find one's place in life, not realizing or completely denying oneself;
- ❖ being out of the public attention;
- ❖ tendency to change their custom;
- ❖ financial poverty;
- ❖ earning money to support his family financially;

## 2. Individual factors:

- ❖ dissatisfaction with life, grief;
- ❖ militancy, heart-burning;
- ❖ to be show-off and separation from others;
- ❖ the presence of a sense of aspiration to anything or an event that is forbidden or unknown;
- ❖ curiosity about any sensational information;
- ❖ eagerness to receive information;
- ❖ high imitation;
- ❖ interest in religious views;
- ❖ presence of selfishness;

## 3. Psychological factors:

- ❖ temperament deviation, aggression, encroachment;
- ❖ Dominance (superiority) of personality traits such as reliability, simplicity and obedience;
- ❖ Disorders of personal life, stress, depression and chronic depression;
- ❖ high susceptibility to external influences;
- ❖ Suffering from mental illness.

“Today, members of various religious radical movements, which are able to subdue the human mind and with the help of modern psychotechnology, have different effects on the mind, but "the purpose of all is to assimilate the characteristics of the group into a new member"[1].

If the next client brings a lot of benefits, the opportunity to bring new clients, then this “bait” will be “developed” by the members of the group in all aspects.

After such processing, the “new client” will soon replace their loved ones, interests and lifestyle with a new environment and aspirations. Such a rapid change has a very strong effect on the psyche, creating stress, but under the constant influence of the group, the stress gradually decreases and occurs conscious obedience.

### Here are some ways to control consciousness, to create obedience:

- Constant control of time and activity causes mental tension, attention deficit, physiological



and emotional exhaustion, weakening of critical thinking of the client. Each member of the group has his or her own duties and they will be strictly controlled and no deviation is also strictly defined from duties which will be observed as the punishment.

➤ Through information control, the client is excluded from the information of the world, he is provided only with special information, data, etc., Which are specific to the activities of the group. The stronger the ideological impact is, the slower the processes in the client is.

Namely, if the constantly transmitted information is controlled and relevant information is given to the person, it is natural that he or she will gradually become a propagandist of this idea and a state of complete obedience to it will emerge.

In the study of the victims of exposure to consciousness mentioned above, attention should be paid, first of all, to the identification of the socio-psychological mechanisms employed by the leaders of the group, which laid the foundation for the development of obedience. “American psychologist J.Lifton, in *Reforming Thoughts and the Psychology of Totalitarianism*, described eight models that lead to a change in consciousness”[2].

**They are the following:**

**1. Constant monitoring of the lifestyle and surroundings of the person.**

At the same time, we try to keep the person being hired from protesting and arguing by giving them a new information and not allowing them to be left alone with their opinions. At the same time, only sweet words should be spoken to him by the society, he should be taken care of, and in most cases, he should be provided the financial support.

**2. Mystical persuasion, manipulation.**

In this case, the deliberately organized situation is absorbed by the client in accordance with the idea of group. For example: wearing hijab, not eating meat, etc.

**3. Demand cleanliness.**

Namely, to divide the issues of the world into “pure”, “impure”, “right”, and “wrong”. The followers of the group are “right” and the rest are “wrong”.

**4. Openness, not hiding secrets.**

Requiring the constant confession of guilt in order to develop a sense of guilt.

**5. Forcing to be recognized the ideas of the group as the most realistic and correct.**

**6. Use the special key words, codes among the members of group.**

Namely, to follow the “language of the group”. In order to do, it is developed a special dictionary, which undermines the basis of independent and logical thinking.

**7. Forcing the people to follow the saying, “The idea of group is superior to man”.**

Namely, to sacrifice oneself for an idea is to absorb thoughts like heroism and so on.

**8. The emergence of the second “I” inside the person which is called “secondary personality”.**

This is the most frightening model, in which the boundary between a person’s previous life and

the life after being exposed, namely, the mind, is subjected to psychological pressure in the analysis of past action and present state. Because manipulation by the group will be aimed at squeezing out previous ideas and values. The fact that all thoughts, emotional states are absorbed by coercion, not by a person's voluntary desire, creates the basis for psychological pathologies. The new "I" resolves internal psychological conflicts under pressure. This model has a strong effect on the human psyche, which intensifies the internal psychological conflicts of man and creates the basis for his complete "manicurism"[3].

One should also stay away from the idea that one can control oneself and leave the team at any time. Because the most religious radical movements actively use such methods of spiritual influence in recruiting new adherents and leave almost no room for retreat.

It should also be noted that any religious radical movement tries to make its teachings attractive, taking into account the vital needs of its "prey". Exposure of the people to such currents is also determined by their over-emphasis on noises that go beyond the scope of various ordinary information. Such attention is fueled by information about the reality of the supernatural phenomena and the processes that are prevalent today. A person who is constantly under the influence of various sources of information becomes prone to accepting unscientific or false religious ideas.

#### **USED LITERATURE**

[1] See: "Psychology of religious sects and movements", Proceedings of the scientific-practical conference. Fergana 2005. 5. p.

[2] "Psychology of religious sects and movements", Proceedings of the scientific-practical conference. Fergana 2005. 9. p.

[3] "Psychology of religious sects and movements", Proceedings of the scientific-practical conference. Fergana 2005. 9. p.

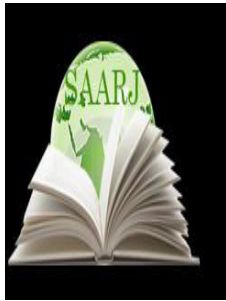

**ACADEMICIA**  
**An International  
 Multidisciplinary  
 Research Journal**  
 (Double Blind Refereed & Peer Reviewed Journal)

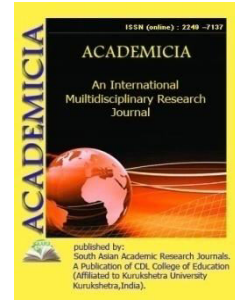

**DOI: 10.5958/2249-7137.2021.01910.8**

## THE EMERGENCE OF THE SCIENCE OF HADITH IN THE EAST

**Bobokhodjayev Sadulla Abdullayevich\***

\*PhD student,  
 International Islamic Academy of Uzbekistan and,  
 Researcher of the Imam Termez International Research Center,  
 UZBEKISTAN

### ABSTRACT

*In addition to accepting the beginning of the hadith translation at the end of the first century AH and the beginning of the second century AH, the emergence of the original hadith works dates back to the first half of the second century AH. Those who deal with the hadiths of the Prophet (peace and blessings of Allaah be upon him) are called those who deal with hadeeths, incidents, stories, and so on. In this regard, the fact that the hadith is synonymous with the Sunnah, which consists of words, verbs and tahr, has been strongly proven in this regard. There was an incident with Abu Hurayra and the Messenger of Allaah (peace and blessings of Allaah be upon him) about the first use of the hadeeth in this sense. The word hadith is a very broad concept in terms of terminology and lexicography, and it is a synonym for the word sunnah. Hadiths were not written down by the Companions in the early days, but some Companions like Abu Hurayrah recorded the hadith in pages.*

**KEYWORDS:** *Lexicography, Synonymous, Terminology,*

### INTRODUCTION

The science of hadith is the first Islamic science to emerge historically. The science of hadith was formed at the end of the third century AH with all its terms and interpretations. Although books on the science of hadith were written much later, the methods, rules, interpretations and definitions were used by hadith imams at the end of the first century, and in the second century AH, these terms were debated by hadith scholars means that it is a pre-established Islamic science. This is evidenced by the fact that the most complete collections of hadiths are classified in the third century AH, which is described as the "Golden Age."

## MATERIAL AND METHODS

There are a number of differences between the lexical and terminological meanings of the word hadith. The hadith, which literally contradicts the ancient (old) meaning of the jadid (new), also comes in the sense of the message. The word is used in some senses, such as to inform, to preach, and to narrate. For example:

*"If they don't believe it, you're probably going to kill yourself out of pity for them"<sup>1</sup>*

In the above verse, the word "hadith" is used in the sense of word and message.

The hadith is described by the scholars of the method. The hadith is deeds, actions and decisions of the Messenger of Allaah (peace and blessings of Allaah be upon him) are called hadith. According to some hadith scholars, the hadith is not only the words of the Messenger of Allaah (peace and blessings of Allaah be upon him) but also the narrations of the Companions and the followers' applies to messages<sup>2</sup>.

## RESULTS

Accordingly, the meaning of the word hadith must be the same as the meaning of the word message. In this sense, the words of the Prophet (peace and blessings of Allaah be upon him) before the Prophet Hood must also have the meaning of a hadeeth. In this regard, there are clear differences between the hadith and the message. Those who deal with the hadiths of the Prophet (peace and blessings of Allaah be upon him) are called those who deal with hadeeths, incidents, stories, and so on. According to the methodology of some scholars, the hadith is used in reference to the words, actions, and takrirs of the Prophet (peace and blessings of Allaah be upon him), and the word is synonymous with the Sunnah in the same sense<sup>3</sup>. Another group of scholars said that there is a common absolute between the message and the hadith, and that every hadith is a message, but not every message can be a hadith. In this regard, the message has a more general meaning, including the words of the Messenger of Allah, may Allah bless him and grant him peace, and the words narrated from the Companions and the followers<sup>4</sup>.

Although there are many differences in the above opinions regarding the tariffs of the hadith, it is certain that when we say a hadith, the words, actions or takrirs (decisions) narrated from the Messenger of Allaah (peace and blessings of Allaah be upon him) come to mind. In this regard, the fact that the hadith is synonymous with the Sunnah, which consists of words, verbs and takr, has been strongly proven in this regard. There was an incident with Abu Hurayra and the Messenger of Allaah (peace and blessings of Allaah be upon him) about the first use of the hadeeth in this sense. Abu Hurayra asked, "Who is the happiest person to have your intercession on the Day of Resurrection?" The Messenger of Allaah (peace and blessings of Allaah be upon him) said to him, "*I knew that you were passionate about hadeeth, so I assumed that no one would ask you about it before you. The blessed person who will attain my intercession on the Day of Resurrection is La ilah illallah*"<sup>5</sup>". It is clear from this hadith that the first use of the word hadith in this sense dates back to the Messenger of Allaah (peace and blessings of Allaah be upon him).

## DISCUSSION

Ibn Shihabaz-Zuhri (50-124) is the first to compile the hadiths into pages. Malik ibn Anas said: "The first person to compile the hadith was Ibn Shihab"<sup>6</sup>". Ibn Shihab himself said, "No one has

compiled this knowledge before me<sup>7</sup>". There is information that Ibn Shihabaz-Zuhri collected hadiths and wrote the collected hadiths. Salih ibn Qaysan, another person who helped him in this matter, said: "Zuhri and I came together to seek knowledge and said that we should write the Sunnah. We have written hadiths from the Messenger of Allaah (peace and blessings of Allaah be upon him). Then Zuhri said, "Let us write down what came from the Companions, and they are Sunnah." I said no, it's not like that. He wrote, I did not write; He succeeded and I lost<sup>8</sup>". It is possible that Zuhri wrote the hadiths first in order to memorize them and then rejected them, because the Messenger of Allah (Allah bless him and grant him peace), forbade them from recording and writing down the hadiths. Over time, various foreign sects emerged in Islam: political and sectarian sects such as the Shia, the Rafidis, the Apostles, the Qadariyya, and the Mu'tazilites. The Islamic Ummah has been tasked with preventing it from happening. At that time, the Umayyad kingdom was in the time of Caliph Umar ibn Abdulaziz. At the same time, the muhaddith began their work of jarh and ta'dil, critically examining the narrators of the hadith, classifying the narrators as trustworthy or unreliable, and classifying each narrator's narration as authentic or weak. In carrying out this work, the Haliha Umar ibn Abd al-'Aziz, known for his jurisprudence, knowledge and piety, also commanded Abu Bakr ibn Muhammad ibn 'Amr ibn Hazm, a scholar from Madinah, to compile authentic hadiths into one book: start by searching for and writing down the hadiths narrated; for I fear the loss of knowledge and the death of the scribes<sup>8</sup>" Imam Suyuti narrated from Abu Nuaym that he wrote this message "in all directions"<sup>9</sup>. After these events, it became clear that Zuhri began to compile hadiths.

In addition to accepting the beginning of the hadith translation at the end of the first century AH and the beginning of the second century AH, the emergence of the original hadith works dates back to the first half of the second century AH. The first hadiths were compiled only and were very difficult to use. This meant that the hadith scholars had to sort and classify the hadiths according to their themes. In such books, there is a section on the subject of each hadith. For example, hadiths about prayer are classified as prayer, and hadiths about zakat are classified as zakat. Another form of classification is the inclusion of the names of the Companions of the Hadith next to this type of books called Musannaf, and books of this form are called Musnad. Only the so-called musnads appear a little later than the musannafs.

Ar-Ramahurmuzi (d. 360 AH), the author of the first work on mustalahu-l-hadith, gives the following information about the first muhaddithin that he considered to be musannif: " As far as I know, the first person to classify and divide the hadiths into chapters was Rabe 'ibn Shubayh of Basra (d. 160), and Sa'd ibn Aruba (d. 156), who was called abd in Yemen but whose real names were Khalid ibn Jamil and Ma'mar ibn Rashid (d. 153), Ibn Jurayj (d. 150) in Makkah, Sufyan al-Sawri (d. 161) in Kufa, Hammad ibn Salama (d. 167), Sufyan ibn Uyayna (d. 198) in Makkah, Walid ibn Muslim in Damascus (d. 195), and Jarir ibn Abdulhamid in Ray (d. 182) , Abdullah ibn Mubarak (d. 181) in Khurasan and Marv, Ibn Abu Zayda (d. 193) in Kufa, Ibn Fuzayl (d. 196), then Abdurrazzaq ibn Hammam (d. 211) and Abu Qurra Musa ibn Tariq in Yemen<sup>10</sup>".

Ibn Hajar said that the reason for the non-collection of hadiths in the time of the Messenger of Allah (Allah bless him and grant him peace) was: " The first is that the Companions were forbidden to compile hadiths to avoid interfering with the verses of the Qur'an, as is stated in the Sahih of Muslim, and the second was that there was no need to write hadiths due to the breadth of their memorization. Most of the Companions did not know how to write. It was only in the last period of the Tabein that the spread of the scholars in different lands and the emergence of

heretics such as the Khawarij and the Ravafiz led to the compilation of the hadiths. Imam Malik classified the book Muwatta. In this book, he collected the hadiths of the people of Hijaz, classified them by mixing the words of the Companions, the fatwas of the followers and those who came after them ...<sup>11</sup>”.

## CONCLUSION

It should be noted that the science of hadith is one of the earliest Islamic sciences. The word hadith is a very broad concept in terms of terminology and lexicography, and it is a synonym for the word sunnah. Hadiths were not written down by the Companions in the early days, but some Companions like Abu Hurayrah recorded the hadith in pages. The period of development of the science of Hadith in the East dates back to the end of the first century AH and the second and third centuries AH. Many collections of hadiths of the Sunan and other types were classified at that time.

## REFERENCES

1. Holy Qur'an Surat al-Kahf 6 verses.
2. Ibn Hajar, Nuhbatu-l-fikr and commentary. –P. 72-78.
3. Al-Qosimiy. Qovaidu-l-tahdis. –b. 35-38.
4. Buxoriy. Sahih. I juz. –b. 33.
5. Abu Nuaym. Hilya. III juz. –B. 363.
6. Muhammad ibn Ja'far ibn Idris al-Hasaniy Al-Kattoniy. Ar-Risala al-Mustarfa. –b. 4.
7. Ibn Sa'd: Tabaqot. II jild –B. 2, 134.
8. Jaloliddin Suyutiy. Tanviru-l-havolik. I juz. –B. 6.
9. Hasan ibn Abdurrahmonar-Ramahurmuziy. Muhaddisu-l-fosilbayna-r-roviyvalvoiy. –b. 611-613.
10. Ibn Hajar Hadyussoriy. –b. 4-5.



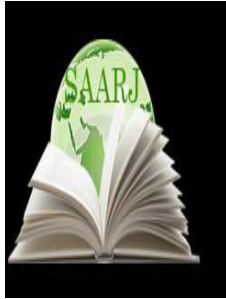

**ACADEMICIA**  
**An International  
 Multidisciplinary  
 Research Journal**  
 (Double Blind Refereed & Peer Reviewed Journal)

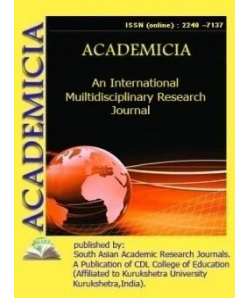

**DOI: 10.5958/2249-7137.2021.01911.X**

**TALMEH (SIGN) IN THE EPIC “KUTADGU BILIG”**

**Barno Abdurahmonova\***

\*Associate Professor,  
 Kokand State Pedagogical Institute,  
 UZBEKISTAN

**ABSTRACT**

*The article talks about the talmeh used in the epic “Kutadgu Bilig”. In order to understand the life event that is the basis for the image in the first verse, the reader must be familiar with the information given in Alisher Navoi's “Historical Property of the Ajam”. The minister looks like Aituldi. It represents a state symbol. A symbol of a stolen mind. He appears in the play as Aituldi's son, who later becomes a minister instead of his father. The transformation comes in the form of a hermit. He is the protagonist of Navoi's work. He is a warrior who has conquered the whole world. The writer calls people to awareness by pointing out that Alexander left this world empty-handed. Noah's story is that he looks at the flood and feels as if he has experienced it.*

**KEYWORDS:** *Art, Talmeh, Image, Gesture, Comparison, Prophets.*

**INTRODUCTION**

Yusuf Khos Hajib, the author of the epic “KutadguBilig”, managed to use many artistic means of classical poetry in his work, following the criteria of art existing in literature, and used some of them effectively. The weight of the visual aids used in the epic shows that the poet has mastered the rules of Turkish poetry, and argues that with the proper application of them, beautiful verses can be written in Turkish.

The creation of a work of art is not related to the demands and desires of the artist. It arises on the basis of demands and needs at a certain stage of development of society.

**THE MAIN FINDINGS AND RESULTS**

Yusuf Khas Hajib's “KutadguBilig” was also written at a time when the Turkic peoples were beginning to recover as a nation. This play shows the socio-political, spiritual and cultural potential of the Turkic peoples. The author considered it expedient to use symbolic images to express his views on statehood. It depicts the ruler-eligKuntugdi. He is a symbol of Justice. The

closest assistant to the ruler is the minister. The minister looks like Aituldi. It represents a state symbol. A symbol of a stolen mind. He appears in the play as Aituldi's son, who later becomes a minister instead of his father. The transformation comes in the form of a hermit. The writer glorifies Justice and Wisdom through the artistic interpretation of these heroes. It artistically demonstrates the qualities and attributes necessary for a person to be happy and prosperous. He effectively uses the subtle possibilities of the Turkish language, because one of the main tasks of the writer was to demonstrate the inner, subtle possibilities of the Turkish language [1, p. 68]. The history of literature also shows that the poet's skillful use of the arts as one of the factors determining the level of creativity. The talmehs used in the epic "KutadguBilig" can also show the author's artistic skill.

Talmeh is one of the most widely used spiritual arts in the epic "KutadguBilig". We have chosen to classify the existing talmehs in the work as follows.

1. Images of prophets;
2. Images of a historical figure;
3. Mythological images:
4. The image of legendary heroes.

The most common image in the epic "KutadguBilig" is the image of the prophets. This is also related to the influence of Islam, especially the Qur'an and other holy books. The writer refers to the image of the prophets in the process of depicting the hero's experiences, his various qualities on the basis of his emotions, philosophical observations. He thinks in the epic about the prophets whose names are mentioned in the Qur'an and their attributes.

Yusuf Khas Hajib in his book "KutadguBilig" mentions dozens of historical and legendary figures such as Jesus Christ, Moses, Noah, Shaddad, Ad, Hazrat Ali, Alexander, Bughrakhan, Rustam, Noshiravon, Karun, Ashobi Ras, AmirTemur, Zakhok, Faridun, Lukman; it created beautiful specimens of talmeh art by quoting their names [2]. Here are some examples:

SukushlugnelugbuldiZakhokdakutun,  
Nelugo'gdibuldiFaridunqutun.

The author cites the legendary heroes of the Turks as an example to him by telling the ruler of his time that the tyrant Zakhak was to blame and Faridun was to be respected. Yusuf Khas Hajib teaches people about several forms of making a good name in the world. He reminds us that after the birth of light, we should live in goodness:

Esizka – so'kush, ezgu - o'g'dubilar,  
O'zunggabaqako'r,qayusunqilur,  
O'zungezgubo'lsa, atingo'g'dilig',  
Qalibo'lsaesiz, so'kush, eysilig.

Meaning: Badly cursed (reprimanded), well-deserved praise, Look at yourself which one do you choose? If you are good, you are worthy of praise, if you are bad, you are doomed to humiliation, O gentleman. And while it was his bad behavior that caused Zakhak to make a bad name in the

world as a reminder to the people, it was his good behavior that caused Faridun to achieve happiness.

A person's character is a mirror that reflects his identity. Therefore, one believes that one should abstain from evil and strive to be virtuous.

The following verses express the poet's wishes and intentions to the king of the time. It is stated that the writer sincerely wants the name of Hakan to be spread all over the world, to be sacred in both worlds:

Sevinchin, avinchin, kuvanchineli,  
Ashasu, yashasunibuLuqmanyili,-deya

Lukman was able to express his love for his people, his people, his homeland, his ruler through his desire to live as a ruler.

Yusuf Khas also refers to a number of legendary and historical figures in the poem "Tell old age with pity to youth" quoted at the end of the epic, and uses talmeh by quoting their names.

Let's look at some more examples:

*I was like Khisrav or Caesarea Rum,  
O Shaddod and Oddek I have built a paradise.  
I conquered the whole world like Alexander,  
I lived to the age of Noah.  
I was Haidar's sword like lightning,  
Oh, I became a voice in the whole world like Rustam.  
O Jesus, I ascended to heaven again,  
Oh I was as fair as Noshiravon.  
Oh, I had a world of wealth like Korun,  
YoAshobiRasdek I built an iron fortress.*

In order to understand the qualities of the people described in the verses of Yusuf Khas Hajib, the reader Shaddad Ad's hope from heaven, Khisrav's cunning, Alexander's rule of the world, Noah's flood and his life of a thousand years, the story of Ali's sword, Christ Jesus having a miracle of resurrection, the righteousness of Noshiravon, the extinction of Karun to the world of wealth, the events associated with the construction of the iron city of Ashobi Ras. After all, the lexical meaning of "talmeh" is "to look out of the corner of the eye", which requires remembering the famous events to which it refers. Yusuf Khas Hajib skillfully uses the events related to the names of historical figures and prophets, using Arabic words as talmeh in the verses quoted.

Talmeh was used in each verse of the byte. In order to understand the life event that is the basis for the image in the first verse, the reader must be familiar with the information given in Alisher Navoi's "Historical Property of the Ajam". Why does the poet liken himself to Khisrav or the Roman emperor? In fact, the incident involving these individuals has nothing to do with the poet.

By pointing to these people, Yusuf Khas Hajib is trying to convey his ideological goal to the ruler, that is, to remind him that life is temporary and the world is not eternal.

In the second byte, Shaddod's paradise-building event is chosen as a life event. At this point, according to the art of talmeh, the reader must be aware of the events related to Shaddod and Ad in order to remember that Shaddad and Ad want to create a paradise for themselves. Alexander, quoted in the third verse, is well acquainted with the reader. He is the protagonist of Navoi's work. He is a warrior who has conquered the whole world. The writer calls people to awareness by pointing out that Alexander left this world empty-handed. Noah's story is that he looks at the flood and feels as if he has experienced it. But life is fleeting, yet it will not be fulfilled. Youth reminds us that old age has come and death is knocking at the door. In the following verses, it is useless for Rustam to make a fuss in the world, to flee to the sky like Jesus, to be just like Noshiravan, to have an innumerable fortune like Karun, and to build an iron fortress to protect him. Life is not given to man forever. That was what Yusuf Khas Hajib meant. Yusuf Khas Hajib, who can deeply feel that man is a guest in this world, considers life, the fact that man lives in life, in a word, to come and live in this world as a moment. He likens life to a caravanserai where people come and stay overnight. Man is a guest in this world. Comes, goes. No matter how he lives, he goes from house to house, from house to house, that is, the world is not eternal, the poet says.

#### REFERENCES

- [1] Tokhliev B. (1991) Yusuf Khas Hajib's work "KutadguBilig". –Tashkent: Uzbekistan. – p 8.
- [2] Tokhliev B. (1989) Problems of poetics of "KutadguBilig". Immortal monuments. – Tashkent: Fan.
- [3] Tokhliev B. (2004) Yusuf Khos Hojib's "KutadguBilig" and development of some genres. Tashkent. Asr-Matbuot. – p. 45.
- [4] Umurov H. (2010) Rules of literature. A Textbook for Academic Lyceums. – Tashkent: Teacher. (Umurov H. Adabiyot qoidalari. Akademik litseylar uchun o'quv qo'llanma. T.: O'qituvchi.2010.)
- [5] Tokhliev B. (2001) Yusuf Khas Hajib and Alisher Navoi. –Tashkent. Matbaa- tongi LLC.



**ACADEMICIA**  
**An International**  
**Multidisciplinary**  
**Research Journal**  
 (Double Blind Refereed & Peer Reviewed Journal)

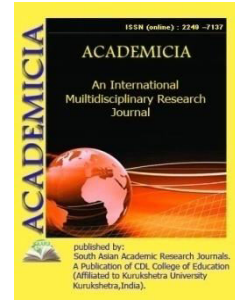

**DOI: 10.5958/2249-7137.2021.01919.4**

## THE DEVELOPMENT OF INTERCULTURAL AND LINGUO CULTURAL COMPETENCE IN HIGHER EDUCATION

**Hilola Muinovna Karoeva\***

\*English Teacher,  
 Samarkand State Architectural- Civil Engineering Institute,  
 UZBEKISTAN  
 Email id: hilolakaroyeva@gmail.com

### ABSTRACT

*This article discusses the importance of the need for the development of intercultural competence of students in higher education and its pivotal role in studying foreign languages, researchers' views and opinions. The emphasis is the need to consider intercultural aspects of teaching English for specific purposes and the components of intercultural competence. Besides, the article analyses individuals' ability to interact with others appropriately, considering the awareness of intercultural competence and social status of the members of the society.*

**KEYWORDS:** *Linguistic Competence, Cultural Competence, Language And Culture, Cognitive, Affective, Cultural, Semiotic Competence, Institutional Competence, Intercultural Communication.*

### INTRODUCTION

In this globalized world, any modern society feels the need to understand and comprehend the linguocultural processes that take place in it. Along with the study of linguistic trends that contribute to the development of linguistic and cultural aspects of nations, it is important to study the factors influencing the adequate formation of modern culture, the introduction of innovative technologies that contribute to the successful adaptation of the personnel in society.

The ability to apply the knowledge gained during our lives in practice, to form the skills to find the necessary solutions to various difficult situations, the development of socio-linguistic factors in the speech of communicators requires relevance in the modern education system. Therefore, it is necessary to scientifically substantiate and develop a methodology for improving the intercultural competence of students of non-philological universities of the Republic of Uzbekistan in teaching English in the context of socio-pragmatic and national-cultural specificity

of verbal communication. Because it is impossible to form linguocultural competence without understanding and mastering language culture, and, in time, it is impossible to master linguistic culture without forming linguocultural competence.

**Main part.** In this article, we want to focus on the need to develop students' linguocultural competence in non-philological higher education institutions and its importance in learning foreign languages. According to many scholars, the structure of linguocultural competence includes:

- linguistic competence (knowledge of different basic language units specific to a particular culture and their application in practice);
- cultural competence (adherence to culturally defined norms), which, in turn, means knowing the norms, rules and traditions of their society, including socio-cultural competence;
- intercultural and cultural competence (knowledge of norms, rules and traditions of other societies).

In this context, the concept of linguocultural competence implies not only the knowledge of a certain number of words and phrases, but also a full understanding and comprehension of the whole set of cultural processes that are close to and predetermine the meaning of these linguistic units. It also means that an individual can successfully interact with other members of society, understand himself and find his place in society, and be competitive in the labor market.

## LITERATURE REVIEW

In the course of our research, we also got acquainted with many works of researchers of our country. Most of them are scientific articles and textbooks aimed at increasing the competence of linguocultural and intercultural communication of students of linguistic higher education. For example, G.T.Mahkamova expressed her valuable views on the advantages of the communicative-cumulative method in foreign language teaching, i.e. the joint study of language and culture [10, 13 p.], S.A. Ziyaeva has done a number of things to improve the sociolinguistic competence in teaching students of linguistic higher education institutions [8, 72 p.], KJ.Rizkulova specifically studied the system of formation of sociolinguistic competence of future English language specialists in accordance with international educational standards in accordance with the requirements of globalization [11, 64 p.].

A number of scientific studies are currently being conducted to ensure that students of non-philological education have a certain level of linguistic, socio-cultural and pragmatic knowledge and skills that allow them to communicate communicatively and purposefully, to change their speech behavior depending on the communication situation. In particular, Monica Cavalir emphasizes the close connection between language and culture in non-formal education institutions, the importance of knowing cultural perspectives in the teaching of career-oriented English and the need to compare them [4, 114 p.]. In her research, Fatma Zaghar acknowledges that an intercultural approach to language teaching in ESP classrooms helps students achieve three main goals: cognitive, affective, and cultural [2, 503 p.]. Alvino Fatini and Akiil Tirmidhi explain that "Language is the key to all doors, and understanding and communicating with and understanding the local culture is the way to common success" [1, 76 p.]. Therefore, it is expedient to develop the competence of intercultural communication not only in students of philological education, but also in students of non-philological universities.



## RESULTS AND DISCUSSIONS

The linguocultural competence of a modern foreign language teacher consists of two components: incultural competence, that is, knowledge of the norms, rules, and traditions of one's own linguocultural community, and intercultural competence that is the knowledge of the general linguistic, cultural norms, and traditions of other linguocultural communities. The components of linguocultural competence include:

- Ordinary competence (knowledge of customs, norms, rules of etiquette);
- Institutional competence (knowledge of political and legal institutions of society);
- Semiotic competence (information about various characteristics of a particular culture, including symbols of social prestige);
- Linguistic competence (knowledge of language in several social variants: oral and written, formal and oral).

If the foreign language teachers are able to develop the above-mentioned competencies in students, then their linguocultural competence is improved through the use of special terms and stages of mastering socially marked language units. At the same time, the arrival of students from different countries to study in our country and the study or activity of our youth in foreign universities demonstrates the need to develop the ability to communicate with other cultures in the workplace and linguistic and cultural competence.

In May 2019, the UK Council, in partnership with the Ministry of Higher and Secondary Special Education, launched a long-term employment program in response to large-scale national reforms aimed at further developing and internationalizing the potential of higher education in the Republic of Uzbekistan. One of the main directions of the program is to develop strategies for teaching specialty subjects in English. Thus, there is a need to take into account the linguocultural aspects in the implementation of the teaching of specialty subjects in English. This determines the relevance of our scientific research.

At the beginning of the XX and XXI centuries, the science of linguistics was enriched with new directions: linguocultural and intercultural communication. Linguoculture is an independent scientific field, the subject of which is the role and importance of language and culture in the formation of personality. The terminological combination of "intercultural communication" was introduced to linguodidactics in the 2000s by Russian scholars [6, 138 p.]. M.O.Guzikova and P.Yu.Fofanova describe it as follows: "Intercultural communication is the interaction and exchange of information between different cultures" [7, 128 p.].

As is known, linguistics is a general theory of language learning. It studies the general laws of teaching languages, the specifics of content, methods and means of teaching a particular language, depending on the didactic goals, objectives and nature of the studied material. According to D. V. Bulatova, a linguistic didactic is an industry didactic, representing as a methodological basis of the theory of teaching foreign languages [5, 81 p.]. Proceeding from this, we need to improve our method of teaching foreign languages, considering regional requirements, professional needs and social science.

It is known that the relationship between linguistic and methodology is not the relationship between theory and practice. Litvinko pointed out that the subject of linguistics is a theoretical

justification and comprehension of the dimensionality of the interaction of teaching a language (teacher's activity), teaching (student's activity), principles of teaching and learning. Linguistics studies the laws of mastering any language, regardless of whether it acts as the first or the second [9, 2-3 pp.]. In the process of professionally oriented teaching of a foreign language, the central category of professional linguistics is the formation of the linguistic personality of a specialist.

As we know that majority of students realize the importance of learning the cultural aspects of a language when they go abroad and face challenges. Although students have sufficient linguistic knowledge, they are not able to communicate at the required level according to socio-cultural rules in the process of communication. It is important to include cultural elements in the process of teaching professionally oriented English in foreign language teaching programs in non-philological higher education institutions. For example, to be able to approach architects from a professional point of view, to express opinions, to express gratitude, to use phraseological units correctly. Goddard and Wierzbicka acknowledged that "every language has its own cultural ornament, it consists of different cultural norms, values and practices" [3, 154 p.]. From exercises on how and when to use cultural aspects of language correctly, it would be appropriate to alternate role-playing games and various situations in the lesson process using educational technologies.

## CONCLUSION

Enhancing students' linguistic and intercultural communication thinking develops their skills such as critical thinking about their own culture and the culture of others, tolerance and respect for the culture of others, and an accurate assessment of the situation. It is expedient to divide the social factors influencing the speech situation of speakers in different communication situations into national-cultural, socio-situational and physiological-mental types according to the linguo-methodological purposes of teaching them. This requires teachers of non-philological higher education institutions to work harder on themselves and look for new technologies.

## REFERENCES:

1. Alvino E. Fantini and Aqeel Tirmiz., Exploring and Assessing Intercultural Competence., Missouri, 2006, 76 p.
2. Fatma Zaghar., Interculturality in ESP Classrooms: A Contributing Strategy to Meet the Job-Market. Oran, Algeria, 2016, 503-512 pp.
3. Goddard C., & Wierzbicka A. Cultural scripts: What are they and what are they good for? London: Sage, 2004, 154 p.
4. Monika Kavalir., Culture in Esp Syllabus: Why and How? Romanian Journal, 2013, 114 p.
5. Bulatova D. V. Theoretical foundations of the course of teaching a foreign language in a non-linguistic university. Abstract of thesis. diss. ... Doctor of Pedagogical Sciences – Moscow – 1999, 48 p.
6. Gudkova DB, SG Ter-Minasova. Language and intercultural communication. Moscow., 2000. – 138c.
7. Guzikova M. O., Fofanova P. Yu. Fundamentals of the theory of intercultural communication. Yekaterinburg., 2015. – 126p.

8. Ziyaeva SA Improving sociolinguistic competence in teaching students of linguistic higher education institutions in German. Doctor of Pedagogical Sciences. (DSc) Author's dissertation.-Tashkent., 2020-72 p.
9. Litvinko F.M. Abstract of thesis. diss. ... Doctor of Pedagogical Sciences – Moscow – 2005, 106 p.
10. Makkamova.G.T. Reflections on the communicative-cumulative method of teaching a foreign language. *Horizhy Philology* No. 1, Toshkent., 2019.– 13 p.
11. Riskulova KD Bulazhak Sociolinguistic Competence Formation for English Language Teachers. Doctor of Pedagogical Sciences (DSc)
12. Rasuljanovna, I. N. (2019). The Phenomenon of Lacunarity as the Linguacultural Issue. *Prospects of World Science-2019*, 226.

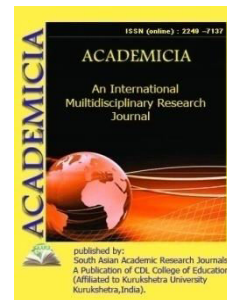
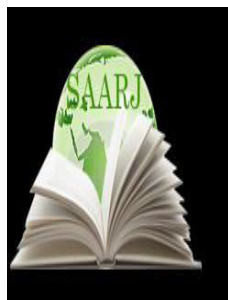

DOI: **10.5958/2249-7137.2021.01913.3**

## THE USE OF AN IMPROVED EXPERIMENT IN TEACHING CHEMISTRY IN THE PROCESS OF CONTINUING EDUCATION

**Akhmadjon Mirzaevich Jumanov\***; **Nargiza Elmirzaqizi Sobirova\*\***;  
**Gulibonu Xusniddinqizi Yusupalieva\*\*\***;

\*Associate Professor,  
Kokand State Pedagogical Institute,  
UZBEKISTAN

\*\*Student,  
Kokand State Pedagogical Institute,  
UZBEKISTAN

\*\*\*Student,  
Kokand State Pedagogical Institute,  
UZBEKISTAN

### ABSTRACT

*This article describes improved experiments on factors influencing the rate of chemical reaction from general chemistry in continuous learning: catalyst and temperature, reagent surface area, dependence on reagent concentration. The more the reader and students know about the rate of chemical reactions, the easier it will be for them to understand the essence and mechanism of chemical reactions. Lack of necessary reagents and equipment in universities requires economical and efficient experiments to practically study the reaction rate and the factors influencing it.*

**KEYWORDS:** *Experimental techniques and methods, reaction rate, factors affecting the reaction rate, catalyst, temperature, pressure, surface area of a substance, concentration of substances, reaction conditions, an increase in the reaction rate.*

### INTRODUCTION

In accordance with the Resolution of the President of the Republic of Uzbekistan Sh.M. Mirziyoyev dated August 12, 2020 No. PP-4805 «On measures to improve the quality of continuing education and scientific efficiency in chemistry and biology» Chemistry in higher and

secondary schools. special and general secondary education requires further improvement in the teaching of natural sciences.

The role and significance of chemical experiments in the formation of students' practical competencies on the basis of lifelong education are incomparable. One of the urgent tasks of modern chemical education is the further improvement of experiments on the «rate of chemical reactions», which is important for science and the field of chemistry.

In chemistry programs of higher, specialized secondary and general secondary education, as well as in state educational standards, much attention is paid to the experience and skills that students need to acquire [1; p. 33.].

It is known that experimental techniques and methods used in the study of chemistry are widely described in the literature [3; pp. 34-35].

Taking into account the above tasks, let us dwell on the approved experiments to study the regularities of chemical reactions, which are supposed to be carried out in the chemistry programs of higher, specialized secondary and general secondary education.

### MAIN PART

In general secondary and higher educational institutions of great theoretical and practical importance is the formation of knowledge and skills on the rate of chemical reaction and its definition, as well as the influence of various factors on the rate of reaction [2; p.35].

The more the reader and students know about the rate of chemical reactions, the easier it will be for them to understand the essence and mechanism of chemical reactions. In the process of observing chemical experiments, they learn that the rate of reactions changes, as well as important factors affecting the reaction (temperature, pressure, concentration of reagents and catalyst).

It should be noted that in the program of the course of general and inorganic chemistry, a special place is given to the knowledge of the rate of chemical reactions. There are experiments on the dependence of the rate of chemical reactions on various factors and their detection, but there are few guidelines. In most cases, teachers are content with listing the factors that increase the rate of chemical reactions.

In our recommended experiments, students will see that the reaction rate depends on temperature, the presence of a catalyst, and the surface area of solids. Substances and catalysts such as bertol salt, potassium permanganate, metallic zinc, marble, hydrochloric acid are prepared for the reaction in precise optimal amounts, the reaction conditions are measured and the experimental results are formulated.

Theoretical and practical teaching of the topic «The rate of chemical reactions and factors affecting it» is considered on the example of the course «General chemistry» in the bachelor's program «Chemistry» of pedagogical universities of the Republic of Uzbekistan and the subject «Chemistry» in secondary schools. At the same time, on an analytical basis, the volume of hours in the curriculum of the subject, the content of the topic in textbooks and teaching aids were studied.

According to the chemistry program of the 8th grade of a comprehensive school on the topic "The rate of chemical reactions and the influence of various factors on it", only 1 hour is given. There are no separate hours allocated for laboratory experiments on this topic. In the modern era, when the formation of practical competencies in students is one of the urgent tasks of modern chemistry education, there is a need to improve practices.

In higher educational institutions, 4 hours of theoretical and 4 hours of laboratory studies are allocated for a bachelor's degree in Chemistry. Lack of necessary reagents and equipment in universities requires economical and efficient experiments to practically study the reaction rate and the factors influencing it. Accordingly, we aimed to build and test an improved experimental device in order to study the reaction rate and the factors influencing it.

Classes 8<sup>A</sup> 8<sup>B</sup> of secondary school No. 16 of the Buvayda district were selected as the object of the experiment. Initially, the knowledge and practical skills of students in this class regarding the rate of a chemical reaction and the factors influencing it were monitored on the basis of oral questioning. According to the results, the quality of assimilation and knowledge of students on the topic did not give the high results we expected.

To ensure the reliability of the results of the experiments, the classes were divided into experimental and control. Class 8<sup>A</sup> was designated as an experimental class and class 8<sup>B</sup> was designated as a control group. In the experimental class, the improved experimental setup developed by us was used only for experiments on the effect of catalyst and temperature on the reaction rate. In the control group, experiments were carried out on the basis of a device consisting of devices given in the laboratory instructions for this subject.

Based on experiments conducted in both grades, students' practical knowledge and skills on the topic were retested to compare quality scores. The analysis showed that the quality of assimilation and knowledge on the chosen topic in the experimental class significantly differs in comparison with the control class. The university carried out a comprehensive study of such factors as the effect of the catalyst and temperature on the reaction rate, the surface area of the reagents and the concentration of substances on the basis of an improved device. As the object of the pedagogical experiment, 101 and 102 groups of bachelor's degree «Chemistry» of the Faculty of Natural Sciences of the Kokand DPI were selected. Group 101 was designated experimental and group 102 as control. The pedagogical experiments were organized as follows. In the experimental group, the effectiveness of the device was tested for studying the effects of "Important factors affecting a chemical reaction (catalyst, temperature, concentration of reagents and surface area of a substance)".

2 conical flasks with a volume of 500 ml (**a**, **a`**) and round tubes with a volume of 100 ml (**b**, **b`**), 2 graduated glass tubes with a volume of 25 ml (**c**, **c`**), 2 lamps (**d**, **d`**) the device is assembled for the study of the electrical conductivity of solutions.

#### **A. Effect of catalyst and temperature on reaction rate**

1. The dependence of the reaction rate on various factors was studied in parallel experiments. The effect of the catalyst and temperature on the reaction rate was studied by oxygen extraction methods. In this experiment, the reaction rate is determined by the volume of the new substance (oxygen) formed. This is due to the fact that solids (MnO<sub>2</sub>, KCl) remain after the reaction instead of the bertol salt. For this, the same amount of 0.73 g of berthollet salt is added to the flasks (**b**,



b) of the device. 0.8 g of  $\text{MnO}_2$  catalyst was added to b. The flasks were heated in one flame and the results were as follows:

1. The flask burns 1 minute after the start of heating (it is known that the catalyst has been added to the flask). 2. Lamp **d** came on after 6 minutes (tube **b** had no catalyst). 3. Both reactions produce the same amount of oxygen (200 ml). Reaction rate in the presence of **a** catalyst,  $V = v/t = 200 \text{ ml} / 1 \text{ min} = 200 \text{ ml/min}$  Reaction rate without **a** catalyst,  $V = v/t = 200 \text{ ml}/6 \text{ min} = 33.3 \text{ ml/min}$

By comparing the rates of these two reactions, students find that the rate of the reaction is increased by a factor of 6 in the presence of a catalyst. In the same order, instead of the berthollet salt, potassium permanganate ( $\text{KMnO}_4$ ) is taken and placed in the same amount (**b**, **b**) in flasks, and flask **b** is heated in **a** flame stronger than the flask.

Heating starts at the same time. Students will see the light bulb illuminate 2 minutes earlier than the light bulb and conclude that the rate of decomposition increases with temperature.

### **B. Dependence of the reaction rate on the size of the surface of the reagents.**

The dependence of the reaction rate on the surface area of the reagents was investigated as follows.

The same amount of 3% HCl solution was poured into the flasks of the device (b, b), the same amount of granular zinc metal was added to the flask b and the same amount of powdered zinc metal (0.49 g) into flask b at the same time. In this case, due to the large surface area of zinc in tube b, the hydrogen in this tube is released so quickly that lamp g is lit 1.5 minutes before the lamp.

After the experiment, the students came to the conclusion that the larger the surface area of a solid, the higher the reaction rate in which this substance is involved.

### **C. Dependence of the reaction rate on the concentration of the substance**

To show that the chemical rate is related to the concentration of the reactants, parts a, b, c of the device were used and the following experiment was performed.

Pour HCl solution (1: 1) into tube b of the instrument, add 3 pieces of marble, 0.9 g each, and record the volume of gas generated every minute and get the following result.

60 ml of  $\text{CO}_2$  was formed in 1 minute. 56 ml of  $\text{CO}_2$  was formed in 2 minutes. In 3 minutes, 40 ml of  $\text{CO}_2$  was formed. In 4 minutes, 30 ml of  $\text{CO}_2$  was formed. In 5 minutes, 14 ml of  $\text{CO}_2$  was formed. From this result, the students saw that the amount of gas emitted decreased over time as the concentration of substances decreased.

They then concluded that there is a quantitative relationship between the reaction rate and the concentration of the reactants.

The decrease in the reaction rate was explained by the dependence on the surface and the amount of marble that reacts. Based on the data obtained in this experiment, the relative reaction rates per minute were determined as follows: 60: 56: 40: 30: 14 or 4.3: 4.2: 2.8: 2.1: 1 expressed in the form, showed that the reaction rate in 1 minute was 4.3 times higher than the reaction rate in 5 minutes, and the reaction rate in 2 minutes was 4 times faster than in 5 minutes. In the experimental group, students' practical skills on the topic "Reaction rate and factors

affecting it" were controlled by oral questioning, which showed that the assimilation of the topic by students and the quality of knowledge significantly increased in comparison with the control group. In conclusion, it should be noted that the study of the rate of a chemical reaction and the factors affecting it in general education secondary schools and its improvement in higher educational institutions in order to ensure the continuity and continuity of teaching, seems to be one of the problems of improving the quality and efficiency of chemistry education.

#### REFERENCES

1. Нишонов М., Тешабоев С. Мактабда кимёдан амалий ишлар.-Т.:Ўқитувчи, 1992.-134 б.
2. Абдуллаев Г.Анорганик кимёдан амалий ишлар.-Т.:Мехнат, 1988.-159 б.
3. Irgasheva G.A., Sirliboyev T.S. Anorganikkimyodanlaboratoriyavamustaqilish mashg`ulotlari.-2005.-114 б.

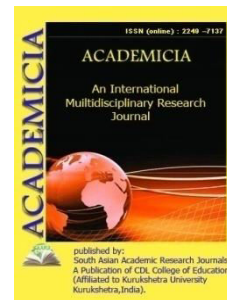

DOI: **10.5958/2249-7137.2021.01915.7**

## ECOLOGICAL ISSUES IN SH.SEITOV'S POETRY

**Konakbay Turdybaev\***

\*Associate Professor,  
Candidate of Philological Sciences,  
Karakalpak State University named after Berdak,  
UZBEKISTAN  
Email id: kturdybaev@mail.ru

### ABSTRACT

*The article notes that the lyrical and epic poetry of Sh.Seitov occupies a significant place in the Karakalpak literature of the twentieth century; they differ in ideological, thematic, genre-stylistic and artistic views. The details of the tragic plot in the resin mix have a special lyrical and psychological color, causing deep thoughts and thoughts in the reader. This enhances the poetic power of his compositions.*

**KEYWORDS:** *Karakalpak Literature Of The XX Century, Ecology, Lyrical Poetry, Epic Poetry, Tragic Plot, Amu Darya, Aral Sea.*

### INTRODUCTION

Lyrical and epic poetry of Sh. Seitov occupies a significant place in the Karakalpak literature of the XX century. They differ in ideological-thematic and genre-stylistic and artistic point of view. Different literary-critical views have also been expressed [1]. However, it cannot be said that the level of research of poetic poetry meets today's requirements. In particular, the peculiarities of the description of the environmental protection exercise in his poetry have not been specifically studied. In this article, we have chosen to focus on this issue. This exercise occupies a significant place in the poetry of Sh. Seyitov. As an object of study, we chose the poems "Will the future see, will the earth bury!", "Give back my Amu Darya" and the poem "Dream".

### THE MAIN FINDINGS AND RESULTS

In a number of his poems, Sh. The details of the tragic plot in the resin mix have a special lyrical and psychological color, causing deep thoughts and thoughts in the reader. This enhances the poetic power of his compositions. From this point of view, the addition of the so-called "Will the future be bright and will the earth be buried?!" resin has a special place. It is safe to say that the

tragedy is predominant and is written from today's life. In fact, it is no secret those in recent years, despite the flooding of the Amu Darya and the relief of the population, the destruction of the Aral Sea and the escalation of environmental disasters. For this reason, it is impossible to exaggerate the pathetic paintings depicted in it with the same idea in the above-mentioned compound of resin. It has, for example, the following rows.

Анамызқулағанда	When our mother fell
«Шүкирет!» дедиәкем,	“Thank you!” said my father,
Булгәп тежылағанға	It's about crying
Тәселлеболадыекен...	It will be comforting...
...Әкемизқулағанда,	... When our father fell,
«Шүкирет!» дедикөстар.	“Thank you” said the birds.
«Ел-халық-булсаған да,	“The country-people are for you,
Атаана!», -дидослар	Parents!” Said the friends
Қәбиргеқыйдымзорға.	I had to go to the grave.
...Топырағыңболсынторқа!»...	... Let the soil be in the net! ”...
Жан әкеманажердин	Dear father, motherland
Қойнындақалаберди!...	It remained in his pocket! ...

It is well-known that death is a tragedy, but it is also a tragedy for everyone. And the readers do not even notice that the resin is beginning to be ready to put forward an idea of great social significance by depicting them in the next rows.

Қостарымқулағанда,	See: When my birds fall,
Жертеўдимжылапанық!	I cried and cried!
«Қой, бала, жылағанды,	“Sheep, baby, cry,
Жертеўме!» дести халық.	Earthquake!” spread the people.
«Жерырысқылкәримиз де,	“The earth is rich,
Қәстерлепсыйлаймыз-ғой!	We respect you!
Бәримиздәримиз бе?!	Are we all drugs?!
Өлмесексыймаймыз-ғой!	We can't live without death!
...Жутса да бәримизди,	... Even if we swallow,
Жерди хешқыймаймыз-ғой!	We will never mow the earth!
Не боптыөлсекелин,	When the bride dies,
Табарсаңшырайлысын!	If you find it, be happy!
Жерөлсежурттың, елдин,	When the earth dies, your land, your
	land,

Тәғдирикүдайбилсин?!	God knows his destiny?!
... Сақлайгөрбетеринен,	... Save the surface,
Шүкирет, жүўернемек!	Thanks, let's go!
Сабайжақмениқойдай,	Leave me alone,
Бир ғаррыТолстойдай...	Like a Tolstoy...

Thus, we realize that the resin is now turning the thoughts to the Mother Earth, and they are arranged by the master of words in the following lines, poetically and ideologically defined:

...Пулжайлапсанамызды, Тыңжайлапкетипаттық. Тәбиятанамызды, Деңгееетипаттық! Әмиўдибиреўшалып, Геллесинбиреўалды. Таласыптүрлихалық, Териси-ақбизгеқалды. Оған да шығып «жарнақ», Абыныпқанжаластық!. Ғағырлапқаттыжарғақ, Сақлаўғажанталастық! -Жангенам, кетпекурып! Шалшықтанбүркипуртлап! Арал да дузсуўырып, Шөлден-ақөлдижуртта!!! Хешкимбулмүсийбетте, Айта алмас: «Шүкирет!» деп! Санамқысыўметбул, Қысыўметшадлығыма! Баламамүсийбетбул, Мүсийбетаклығыма!...	... We count money slowly, We left slowly. Mother Nature, We shot to the level! Someone called Amu Darya, Someone got Hellesin. Different people quarreled, The skin is also left to us. He also went out to "pay", We stumbled and bled! It's too tight, We strive to save! - Zhangenam, doesn't leave! Spray from the puddle! The island also draws salt, He died in the desert!!! No one in this tribulation, He cannot say, "Thank you!" that! Please be patient, Congratulations! My child is miserable, My misfortune! ...
---	---

It is true that the death of Amius and the Aral Sea, in turn, coincided with the death of our Motherland. It is obvious that the resin poetically poisoned it and managed to convey it to the students in a symbolic and metaphorical way. It is worth considering this as one of the great achievements of our national poetry in the era of impartiality. Poet's redefining and sharpening of such achievements is in line with the ideas of today's democracy and free-thinking.

Әмиўжоқ, Аралымжоқ! Шүкирликетеалмайман! Хешқайдабарарымжоқ, Безип те кете алмайман! Кетпесемқақланарман,	See: No Amu Darya, There is no island! I can't be thankful! I'm not going anywhere, I can't even decorate! If I don't leave,
--	---

Дузланыпсақланарман.	I'll keep it salty.
...Жерөлдидегенгесол,	... The earth is dead,
Көрсем де исенеалмайман.	I can't believe it.
Туұғанжерсорлапөлсе,	If the homeland sucks and dies,
Кең-ғойол,	It is wide,
Көмеалмайман!	I can't bury!
Мен өлсем-бираршынжер,	When I die, a throne,
Жерөлсеқайдасыяр!	Where the earth dies!
Ким кимге «Шүкирет!» дер,	“Thank you!” soon,
Оның не пайдасы бар?!	What good is it ?!

This is a very modern and sharp idea, in which each of us must fight for the destruction of the Motherland. The sharpness of poet's journalistic and philosophical work in this collection, the uniqueness of the artistic image is clearly seen in such steps.

One of the most modern lyrics of Sh. Seitov is called “Give back my Amu Darya”. It was a real anthem of his time. We believe that the fact that our song has been performed by our singers has also increased its impact on the general public. Bravely throwing the exercises of the epoch with great courage, he highlighted the problems of the Aral Sea, the Earth and the Water with a special urgency. Although the compound is not included in the poetic collections of resin, we think it is appropriate to take it simply from school and lyceum programs and textbooks. Poet's skillful eloquence, sharpness of thought, and the ability to express his thoughts in gay situations in connection with religious beliefs are of particular interest to the reader. This is similar to the ideological and aesthetic principles of description in the poem “Commander is also a soldier”.

-Тилиңнен без! деди, бездимтилимнен,	For example: he said, tired of my tongue,
-Диниңненбез!-деди, бездимдинимнен,	“We are from your religion!” He said.
Алдыңдабозлайынболып боз инген,	In front of you is a gray bear,
Аллам әпиұеткилаұыргүнамды...!	May Allah forgive my grave sin...!

Шешенгеисендималдадымени,	I believed in Sheshen, he deceived me,
Көсемгеисендималдадымени,	I trusted my leader, he deceived me,
Басқасыйынарымқалмадыенди,	I have no more prayers,
ҚайтарыпбермениңӘмиұдәрьямды [8, p. 149].	Give back my Amu Darya.

It is obvious that the reality of the epoch described in these lines and the depth of realism in its illumination, the strict presentation of the truth immediately attracts the reader's attention. Poet once again sharpened and clarified his thoughts:

Сорлыпешанамныңшорынжуұайын,	Let me wash the sorrow of my sorrowful
Анамныңшорашқангөринжуұайын.	forehead,



Мағанауызсуўбер, еринжуўайын, ҚайтарыпбермениңӘмиўдәрьямды.	I wash my mother's salt. Give me a drink, and I will wash my lips. Give back my Amu Darya.
Өзинәдалатлы, өзинҳақболсаң, Бәршехалыққаәдилқарамақболсаң, Қарақалпақхалқынқырмайжақболсаң, ҚайтарыпбермениңӘмиўдәрьямды! [8, 150].	If you are just, if you are right, If you want to be fair to all people, If you don't want to kill the Karakalpak people, Give back my Amu Darya! [8, p. 150]

It is obvious that poet, having appealed to the whole society - both the leader and the couple, has achieved the sharpness of his idea, very successfully invented a poetic way to express himself boldly. For this reason, due to the effectiveness and weight of the idea, it has taken a certain place in our national poetry in recent years, has served to increase the social activity of our literature.

Sh. Seitov's poem "The name of the dream" is one of the masterpieces in our literature on the topic of environmental protection. The poem is written for school-age children, it deals with the most pressing issues of the time, the issues of land, water and ecology. The work skillfully reveals the image of several teenagers.

The plot of the work is short: one day, out of nowhere, not far from the lake called "Botakoz Lake", children Bakhtiyar and Anwar, who were going to school, found eight goosebumps. At first, the children think that they can cook and eat them by adding them to two pies given to them by their grandmother. But Anwar, who is gentle and kind, is against it. For this reason, children take the puzzles back to their nests. But a relative of those children, Sharyar, puts these skulls under a chicken in his house. And he puts his own pair of brains in the goose's nest. As the days go by, there are dozens of goose chicks in the house. But it will be difficult for them to get used to the water in the pond, around the fence. Realizing this, an old woman named Bazar blames Sharyar, but he gets rid of the fact that he bought gas cans from a neighbor named Gazturgan. And in the lake, two wild chickens from a goose's nest begin to grow. Its secret is revealed to children only in winter. This was reported in the newspaper "Zhetkinshek" and interesting stories were published. Shayir describes it as follows:

«Жеткиншекте» сенсация,	Sensation in "adolescence",
«Тыңла! Тыңла, дүнья!»	"Listen! Listen, world! "
Жупжубайыжабайытауық,	A pair of wild chickens,
«Уялыға» келгенауып.	The threat to the "cell".
Қашан, қайсыматериктен,	When, from which continent,
Булауылғакелиппиткен.	He came to this village.
Жигирмадайшөжеси бар,	He has about twenty grandchildren,

Гәсиқызыл, гәсишубар!	Very red, very dry!
Дур-дур ушарқырғауылдай,	Like a pheasant,
Тауық бар масирәбундай?!»[9].	Is there a chicken like that?! ”[9].

Thus, the lake will be turned into a special reserve, where wild chickens and other animals, birds and wildlife will be preserved.

However, the explorers began to destroy the wildlife by burying the lakes of this place, as well as other places. Bakhtiyar, Anwar and Sharyar, who were against the bulldozers, were joined by their old sister Kurban Mama, who did not leave the tractor. As a result, the tractor driver fled, despite the orders of his boss.

Бульдозершиырғыпжерге:	Bulldozers jumped to the ground:
- Кеттим, - деди –министрге.	“I'm gone”, he said to the minister.
Тоғайқуртыў план емес,	Deforestation is not a plan,
Адам дегенжыланемес!	Man is not a snake!
Пашырлатып баса алмайман,	I can't walk,
Хүжданымнанқашаалмайман!...[8, p. 149]	I can't escape my conscience! ... [8, p. 149]

Thus, the name will be transformed into a large nature reserve “Botakoz Lake”. In addition to pheasants, crocodiles, bears and tigers are brought there, and a world of birds - animals - appears. The tiger is not trapped, but he can walk with people. He describes them with the power of hilarious artistic imagination:

Бултоғай, көлмәңгиқорық!	This grove, lake is an eternal reserve!
Қамысын да болмасорып!	Reap the reeds!
Тоғайшапқансудланады!	The grove will be judged!
Малы - мүлкихатланады!	Livestock - property is registered!
Қусынатқанатылады!...	The bird is shot! ...
... «булжабайы экс тауық,	... “This is a wild ex chicken,
Қайықлымнанкелгенауып...!»	What a shock! ”
...Селтеңбермеңоқыушылар,	... Don't shake students,
Жым -жыртлықтанилимтууылар...!	Science is born from silence...!
...Суўдажатырзил, қаразил,	... Truck, black truck, lying in the water,
Гаваналыкрокодил .	Havana crocodile.
Асыпкелгенуақтаудан,	From a long mountain,
Айыўларжүраудан-аудан,	Bears go from village to village,
Қуслардың бар любой түри,	There are all kinds of birds,
Аққуларма? Пожалуйста!	Swans? Please!

Зоолог келерМагаданнан,	A zoologist comes from Magadan,
Ҳиндлеркелсежақларпилди.	If the Indians come, the sides are elephants.
...Не жетпейди бунда және,	... What is missing here and,
Айтың, дослар, айтың, қәне!	Tell me, friends, tell me!
Бола қалдыхәммеуў-шуў:	It all happened:
-Суўжетпейди, суўкерек, суў!	- There is not enough water, we need water, water!
-Дыққаткеректәбиятқа!... [8, p. 28].	- We need to pay attention to nature! ... [8, p. 29].

Therefore, the preservation of nature as the apple of the eye is the main idea of the poem. Poet Sh. Seyitov successfully described it to the students with a clear and understandable, figuratively sharp language, a compact plot.

### CONCLUSION

To conclude, we can see from Sh. Seitov's analysis of the above-mentioned two verses and the poem "The Name of the Dream" that the resin pays great attention to the practice of nature protection, and in this direction created artistic images of high educational value.

### REFERENCES

1. Akhmetov S. Karakalpak Soviet Poetry. Nukus: Karakalpakstan, 1988.
2. Orazymbetov K. Artistic pursuit in modern Karakalpak lyricism (80s). Knox: Knowledge, 1992.
3. Orazymbetov K. Evolution and typology of artistic forms in modern Karakalpak lyricism (1970-2000). Nukus: "Knowledge; 2004.
4. Dosymbetova A. Art form in Sh.Seyitov's lyrics. Candidate of Philological Sciences. Dissertation abstract. Nukus, 2008.
5. Dosymbetova A. Characteristics of the use of symbolic pictorial methods in Sh. Seitov's lyrics // Herald of UzRIAB, 2008, No. 1.
6. Аяров А. (2010) Karakalpak journalistic lyrics of the independence period. Candidate of Philological Sciences. Diss. Abstracts. – Nukus.
7. Gaylieva O. (2006) Ideological-thematic and artistic features of intermediate forms in Karakalpak literature. Candidate of Philological Sciences. Diss. Abstracts. – Nukus.
8. Textbook. For 6th grade. NökisBilim, 2005. – p. 149.
9. Seitov Sh. (1995) The name of the dream. Poem and narrate. Nökis: Karakalpakstan. – p. 27.



**ACADEMICIA**  
**An International**  
**Multidisciplinary**  
**Research Journal**  
 (Double Blind Refereed & Peer Reviewed Journal)

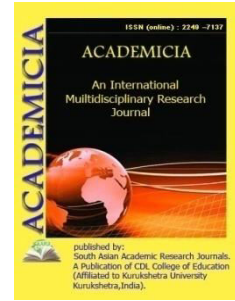

**DOI: 10.5958/2249-7137.2021.01916.9**

## ANALYSIS OF THE PRACTICE OF TRANSPARENCY IN BUDGET POLICY IN UZBEKISTAN

**Gulmira Muzaffar kizi Samandarova\***

\*Basic Doctoral Student,

Tashkent State University of Economics,  
 UZBEKISTAN

Email id: gulmira\_muzaffarovna@mail.ru

### ABSTRACT

*The article analyzes the current state of the principle of transparency of budget policy in the country in detail. Opinions of international scholars on ensuring the principle of transparency of budget policy were studied, conclusions were made on ensuring the transparency of budget policy in my country. In particular, the Resolution of the Cabinet of Ministers of the Republic of Uzbekistan dated October 20, 2018 No 841 "On measures to implement national goals and objectives in the field of sustainable development until 2030" was adopted to set national goals in the framework of sustainable development goals in our country[2]. As a result, public sector finance is seen as a mechanism for transparency, reduction of corruption, public access to budget reports, and more efficient use of budget resources.*

**KEYWORDS:** *Budget, Transparency, Fiscal Policy, Fund, Draft Budget, Budget Transparency, Portal.*

### INTRODUCTION

It is known that since the early years of independence of Uzbekistan, creative work has been carried out in all spheres to increase the economic power of our state, the well-being of our people. Thanks to these efforts, today our country has embarked on a path of sustainable economic development, a layer of landowners has emerged, which has led to a steady increase in family income, and the growing prestige of our country in the world community. The basis of these changes is consistent reforms, smooth and sustainable growth of production and services in all sectors and industries of the economy.

Although ensuring budget transparency in many respects involves the provision of information on the movement of budget funds to the general public, the main factor influencing it is the size

of the state budget. Because the data obtained from the budget transparency is mainly quantitative, it is natural that the population is interested in the planning and execution of the state budget, in particular, its revenues and expenditures. International experience also shows that budget efficiency is promoted by the United Nations under the name of "Sustainable Development Goals". Although the goals of the countries are different, the most important ones today are the 17 goals, which include 169 tasks and 244 indicators used to monitor and evaluate their implementation.[1]

In Uzbekistan, all initiatives put forward by the United Nations, including those for sustainable development, have always been supported. In particular, the Resolution of the Cabinet of Ministers of the Republic of Uzbekistan dated October 20, 2018 No 841 "On measures to implement national goals and objectives in the field of sustainable development until 2030" was adopted to set national goals in the framework of sustainable development goals in our country[2]. According to this decision, the national sustainable development goals have been set in our country, and their total number is 16 and 124 tasks have been selected to achieve them.

### **References analysis**

In the course of the analysis of the literature on the subject, we have seen that a number of leading economists and experts have conducted research on the current state of the principle of transparency in fiscal policy in Uzbekistan, and they include the following. In particular, A.A.Mikhailova, V.V.Klimanov, A.R.Rabadanova studied the impact of openness and transparency of national budgets and other indicators in the field of public administration on the position of countries on the Human Development Index (Human Development Index). Using the econometric apparatus, the significant positive effect of the budget openness indicator on III was revealed[3].

O.I.Timofeeva, Yu.V.Belousov, One of the trends in the development of modern public administration is to increase its transparency, including in the field of public finance management. In international practice, there are mechanisms for assessing the level of transparency of budget data (for example, the budget transparency index calculated by the International Budget Partnership for countries around the world)[4], However, it was noted that many states do not yet exist.

As a result of many years of research by Yu.V.Krivorotko, increasing the openness and transparency of budgets leads to positive changes. As a result, public sector finance is seen as a mechanism for transparency, reduction of corruption, public access to budget reports, and more efficient use of budget resources. He also noted the effectiveness of the formation of resources that can be used to address the most important problems of socio-economic development in a number of sectors of the social sphere[5] and focused on detailing the approaches of transparency in fiscal policy to reveal the impact on the economy.

### **Research methodology**

In our country, economic research methods such as the study of data, data collection, analysis, synthesis, logical thinking, conducted by scientists and economists of the world to increase transparency in budget policy, are widely used.

### **Main part**

The fact that the planning of the state budget is a key part of budget transparency is also mentioned in the "Budget Transparency Index", which is a specific measure of budget transparency at the international level. In particular, questions 1-53 of the 133 questions used in its evaluation include the budget proposal and its consideration[6]. The development of the budget proposal, of course, means the stage of budget planning, and the transparency of this process is especially important in the index methodology.

Therefore, in our opinion, in our analysis, along with the implementation of the state budget, we must pay special attention to its planning.

In turn, budget planning is divided into two major parts, which consists of planning of revenues and expenses. While both are very important, today, in most cases, information on budget execution is more than data on his plans. The reason for this is that the "data disclosure mentality" or plan indicators that have been formed over the years have undergone regular changes.

When planning the budget, its revenue part is related to the income of the population, and the formation of the revenue plan naturally affects the taxes, which are the main part of the budget revenues of the country. And because the population is the main taxpayer, the focus on budget revenue planning actually means focusing on our own future revenues. Therefore, in our opinion, when disclosing the budget, it is necessary to disclose the part of its revenues while it is still planned.

The expenditure part of the state budget has an impact on all aspects of citizens' lives. That is why ensuring its openness is definitely a priority.

In this case, the process of its planning is also important for citizens to see in what areas and for what purposes the budget funds, formed on the basis of taxes paid by them, will be spent.

The interest of the population in budget expenditures can certainly outweigh budget revenues. Because the population is more directly involved in the implementation of these costs than in the formation of income. In our opinion, the participation of the population at the cost planning stage, on the one hand, helps to make the expenditures targeted and efficient, and on the other hand, serves as an information for public control. That is, the public with information on the budget planning phase will have enough information in advance to participate in its future implementation.

Therefore, in our opinion, the above data substantiate the importance of disclosure of information on the budget planning stage in ensuring budget transparency.

In view of the above, we consider it appropriate to begin our analysis with the analysis of the state budget, ie the planning and execution of its revenues and expenditures, as well as the analysis of differences in plans and performance (surplus or deficit).

**TABLE 1 ANALYSIS OF THE RESULTS OF STATE BUDGET PLANNING AND ITS IMPLEMENTATION<sup>1</sup> [7]**

*(TRLN. SUM)*

Indicators	2016	2017	2018	2019	2020
<b>Budget revenues</b>					
Plan	40,8	48,5	62,5	102,6	128,7



Execution	41,0	49,7	79,1	112,2	132,9
Difference (execution plan)	<b>0,2</b>	<b>1,2</b>	<b>16,6</b>	<b>9,5</b>	<b>4,2</b>
<b>Budget costs</b>					
Plan	41,4	49,1	74,0	113,5	144,2
Execution	40,9	49,3	79,7	118,0	144,1
Difference (execution plan)	<b>-0,5</b>	<b>0,3</b>	<b>5,7</b>	<b>4,5</b>	<b>-0,04</b>
<b>Budget execution (surplus (+); deficit (-))</b>					
Plan	<b>-0,6</b>	<b>-0,6</b>	<b>-11,5</b>	<b>-10,9</b>	<b>-15,4</b>
Execution	<b>0,1</b>	<b>0,3</b>	<b>-0,6</b>	<b>-5,8</b>	<b>-11,2</b>

By analyzing the data in Table 1, the following conclusions can be drawn on the planning (forecasting) of budget revenues and its implementation:

- During 2016-2020, the state budget revenues were executed in excess of the regular plan. In particular, in 2018, the plan of budget revenues was set at 62.5 trillion soums, but its implementation reached 79.1 trillion soums, which is 16.6 trillion soums more than planned. The positive difference between the revenue plan and its implementation in 2020 amounted to 4.2 trillion soums. While such a surplus of the budget revenue plan is gratifying on the one hand, it raises many questions about the effectiveness of planning on the other;

- the plan and execution of state budget revenues in 2020 compared to 2016 increased by 3.1 and 3.2 times, respectively. Such an increase in budget revenues, of course, necessitates the disclosure of information on its main sources. In this regard, the increase in budget revenues can be assessed primarily as a result of reforms in tax policy. The following conclusions can be drawn by analyzing the data on planning and execution of budget expenditures presented in Table 1:

- The expenditure plan of the state budget for 2020 and its implementation increased by 3.5 times compared to 2016. This indicates a sharp increase in budget expenditures in 2016-2020. If we look at the changes in the plan and execution of budget expenditures in 2016 compared to 2019, taking into account the increase in budget expenditures due to the pandemic, which began in 2020 and continues to this day, we can see that this plan increased by 2.7 times and 2.8 times in execution. From this you can conclude that there is a steady increase in budget expenditures. In this context, we believe that the need to disclose information on budget expenditures will be higher than ever;

- Execution of budget expenditures in 2016-2020 has in many cases exceeded its plan. This means that budget expenditure data is constantly changing. In particular, in 2018, the budget expenditure plan was set at 74.0 trillion soums, but its implementation reached 79.7 trillion soums, which is 5.7 trillion soums more than planned. In 2020, the expenditure plan amounted to 144.2 trillion soums, its implementation amounted to 144.1 trillion soums, which is 44.0 billion soums less than planned. However, the amount of expenditure differs sharply in planning and execution relative to budget revenues.

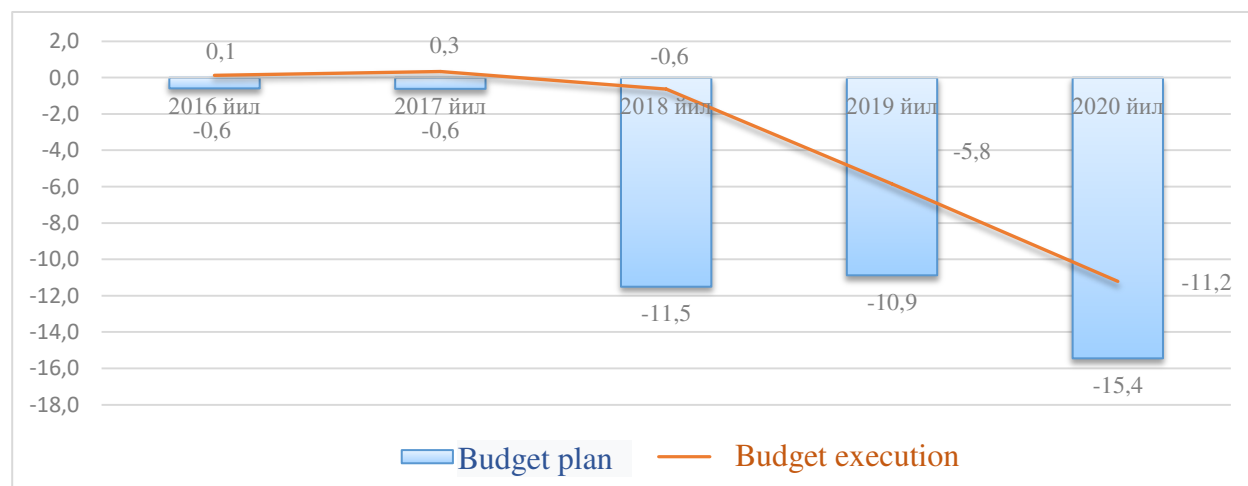

**Figure 1. Differences in the plan and execution of the revenue and expenditure part of the state budget for 2016-2020<sup>2</sup>**

In particular, the analysis of the budget execution (surplus (+); deficit (-)) part of Table 1 shows that the planned amount of budget revenues in 2016-2020 was lower than the budget expenditure plan, which means that the budget was planned with a deficit.

In particular, we can see from Figure 1 that the deficit in the plan of revenues and expenditures of the state budget amounted to 0,6 trillion soums in 2016, 0,6 trillion soums in 2017, 11,5 trillion soums in 2018 and 10,9 trillion soums in 2019. trillion soums, and in 2020 - 15.4 trillion soums.

**TABLE 2 FORECAST OF STATE BUDGET REVENUES AND ANALYSIS OF ITS IMPLEMENTATION, (BLN.SOUMS)**

№	Indicators	Years				
		2016	2017	2018	2019	2020
1	<b>Direct taxes</b>					
	Forecast	9839,3	11365,1	12808,3	27206,8	42161,2
	Execution	9852,8	11539,4	15656,2	31676,8	45206,9
	<i>Difference (execution-forecast)</i>	<b>13,5</b>	<b>174,3</b>	<b>2847,9</b>	<b>4470,0</b>	<b>3045,7</b>
2	<b>Indirect taxes</b>					
	Forecast	21063,1	25724,9	34132,1	45951,1	45348
	Execution	21130,7	26133,2	41280,4	46428,5	46428,4
	<i>Difference (execution-forecast)</i>	<b>67,6</b>	<b>408,3</b>	<b>7148,3</b>	<b>477,4</b>	<b>1080,4</b>
3	<b>Resource fees and property taxes</b>					
	Forecast	5286,7	6457,4	9736,9	17841,3	20386,9
	Execution	5306,3	6867,4	12663,4	19680,8	21256,9
	<i>Difference (execution-forecast)</i>	<b>19,6</b>	<b>410,0</b>	<b>2926,5</b>	<b>1839,5</b>	<b>870,0</b>
4	<b>Other income</b>					
	Forecast	4621,0	4928,6	5822,7	11628,5	20849,6
	Execution	4753,7	5141,0	9499,0	14379,3	20045,8
	<i>Difference (execution-forecast)</i>	<b>132,7</b>	<b>212,4</b>	<b>3676,3</b>	<b>2750,8</b>	<b>-803,8</b>

Execution of the revenue and expenditure side of the state budget ended in 2016-2017 with a surplus, but in 2018 it ended with a deficit of 0,6 trillion soums, in 2019 - 5.8 trillion soums, and in 2020 – 11,2 trillion soums.

Covering the budget deficit, in turn, will increase public debt, which is a special way to further increase budget transparency.

Such differences in budget plans and their implementation necessitate a separate in-depth analysis of its revenue and expenditure side.

We can also see that the execution of budget revenues exceeds its plan in terms of types of revenues through the data in Table 2.

By analyzing the data in Table 2, we can draw the following conclusions:

- state budget revenues tend to grow steadily unevenly in terms of its composition. In particular, direct tax revenues in 2016 amounted to 9.8 trillion soums or 24,0% of total budget revenues, while by 2020 it will be 45.2 trillion soums or 34,0% of total budget revenues. If we look at the main reason for this, we can see that the corporate income tax has increased sharply<sup>3</sup>.

If we analyze the implementation of the plan of direct taxes, in 2016 the execution was 13.5 billion soums more than planned, and by 2020 this figure will reach 3.0 trillion soums;

- Although the changes in indirect taxes in Table 2 are increasing in quantity, the share of these types of taxes in total state budget revenues is declining.

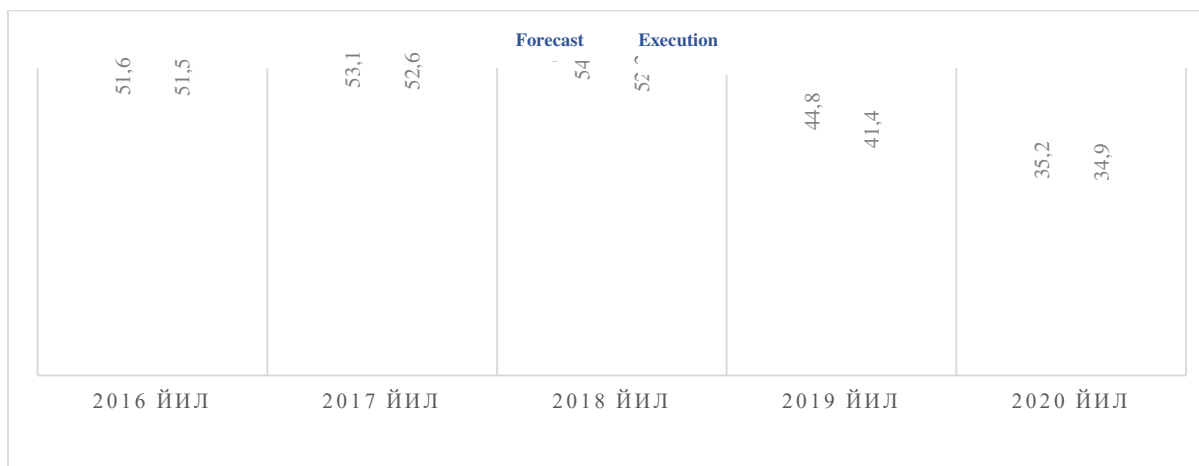

**Figure 2. The share of indirect taxes in total state budget revenues<sup>4</sup>**

If we look at the data in Figure 2, the share of indirect taxes in total state budget revenues is declining, from 51.0% in 2016 to 35.0% by 2020. In 2018, the share of these taxes in the total state budget revenues was the highest, with a forecast of 54.6% and an execution of 52.2%;

- The amount of resource fees and property taxes shown in Table 2 also has a steady upward trend. In particular, the forecast of resource payments and property taxes in 2016 amounted to 5.2 trillion soums, and by 2020 it will increase by almost 3.9 times to 20.4 trillion soums. By 2020, the performance will increase by 4 times compared to 2016 and amounted to 21.3 trillion soums. Therefore, in 2020 alone, 870.0 billion soums more than the forecast was transferred to the budget from these taxes.

- in other incomes we can observe the same trend, an increase in quantity. However, we can see that in these revenues the forecast for 2020 was not fulfilled, which is less than 803.0 billion soums.

In general, 2018 was the first turning point in terms of state budget revenues, while the year 2020 had a significant impact on the structure of revenues and their share with the adoption of mandatory measures due to the pandemic. At the same time, in accordance with the Resolution of the President of the Republic of Uzbekistan dated August 10, 2017 No. PP-5147 "On measures to radically improve the activities of the Accounts Chamber of the Republic of Uzbekistan", the Accounts Chamber Integrity Inspection". Due to the activities of this structure, additional sources of budget revenues have been identified and collected in the budget, leading to an increase in budget revenues in the period after 2018.

We can also say that the new version of the Tax Code, adopted on December 30, 2019, has led to significant changes in the structure of budget revenues. As a result, the volume of taxpayers also increased sharply, and tax rates were reduced.

That is why it is important to inform the population about such changes in ensuring budget transparency. This not only provides information on the taxation of their income through tax reforms and procedures, but also is very important in increasing the economic activity of the population. Because it is natural for a person who wants to do any business to be interested in taxes in the first place.

Changes in budget revenues are also important because they are a source of budget expenditures. That is, the implementation of budget expenditures certainly depends on the receipt of budget revenues. Execution of budget expenditures is ensured through the implementation of budget revenue plans.

**TABLE 3 STATE BUDGET EXPENDITURE PLAN AND ANALYSIS OF ITS IMPLEMENTATION<sup>5</sup>, BLN. SOUMS**

№	Indicators	Years				
		2016	2017	2018	2019	2020
1	<b>Social costs</b>					
	Forecast	24279,2	27204,9	41014,3	62074,4	75120,8
	Execution	24112,6	27235,3	42676,7	63580,3	74279,3
	<i>Difference (execution-forecast)</i>	-166,6	30,4	1662,4	1505,8	-841,5
2	<b>Costs of the economy</b>					
	Forecast	4365,8	5237,2	7416,4	17746,3	16378,0
	Execution	4319,5	5280,7	7637,8	18481,0	16692,8
	<i>Difference (execution-forecast)</i>	-46,3	43,5	221,4	734,7	314,8
3	<b>Costs of financing centralized investments</b>					
	Forecast	2147,5	3119,9	4404,8	5630,2	18539,8
	Execution	2089,1	3234,7	5400,4	7048,5	18843,7
	<i>Difference (execution-forecast)</i>	-58,4	114,9	995,6	1418,3	303,9

4	<b>Expenditures on maintenance of public authorities, administration, justice, prosecutor office and judiciary</b>					
	Forecast	1359,9	1850,2	2755,0	4813,2	7380,3
	Execution	1363,4	1931,1	3275,4	5319,3	7826,4
	<i>Difference (execution-forecast)</i>	3,5	80,9	520,4	506,1	446,1
5	<b>Expenditures on maintenance of citizens' self-government bodies</b>					
	Forecast	460,3	508,0	611,5	695,6	815,0
	Execution	459,1	498,6	603,5	701,0	816,6
	<i>Difference (execution-forecast)</i>	-1,2	-9,4	-7,9	5,4	1,6
6	<b>Reserve funds</b>					
	Forecast	120,0	323,0	733,4	1023,0	1650,0
	Execution	101,8	312,2	604,2	985,4	1506,2
	<i>Difference (execution-forecast)</i>	-18,2	-10,8	-129,2	-37,6	-143,8
7	<b>Others</b>					
	Forecast	8667,3	10846,8	17064,7	21517,3	24303,0
	Execution	8465,7	10851,1	19538,2	21893,3	23360,1
	<i>Difference (execution-forecast)</i>	-201,6	4,3	2473,5	376,0	-942,9

Budget expenditures are a key category in budget transparency, as noted above. Although the practice of disclosing budget expenditure data has varied over time, it has largely meant disclosing quantitative data.

It should be noted that in our country, starting from 2018, the Ministry of Finance has been publishing the publication "Budget for Citizens" on the draft budget and its implementation.

At the same time, the Ministry of Finance has launched [openbudget.uz](http://openbudget.uz) - an open budget portal, which today provides access to information on budget expenditures by budget organizations.

From the data in Table 3, we can see that the budget expenditure plan and execution had unstable changes. In particular, the expenditures for the maintenance of public authorities, administration, justice, the prosecutor's office and the judiciary in 2016-2020 were consistently exceeded compared to the plan, while the plan of reserve funds was not implemented during these years.

In general, we can draw the following conclusions from the data in this table:

- The budget expenditures are directed to social spending. In particular, in 2016, the implementation of the social spending plan amounted to 24.3 trillion soums, and by 2020, this figure was 75.1 trillion soums and 74.3 trillion soums, respectively. It can be seen that the social spending plan in 2020 increased by 309% compared to 2016 and by 308%.

The fact that the amount of social spending is growing, but the amount of total budget expenditures is also increasing, makes it necessary to analyze its share in total budget expenditures.

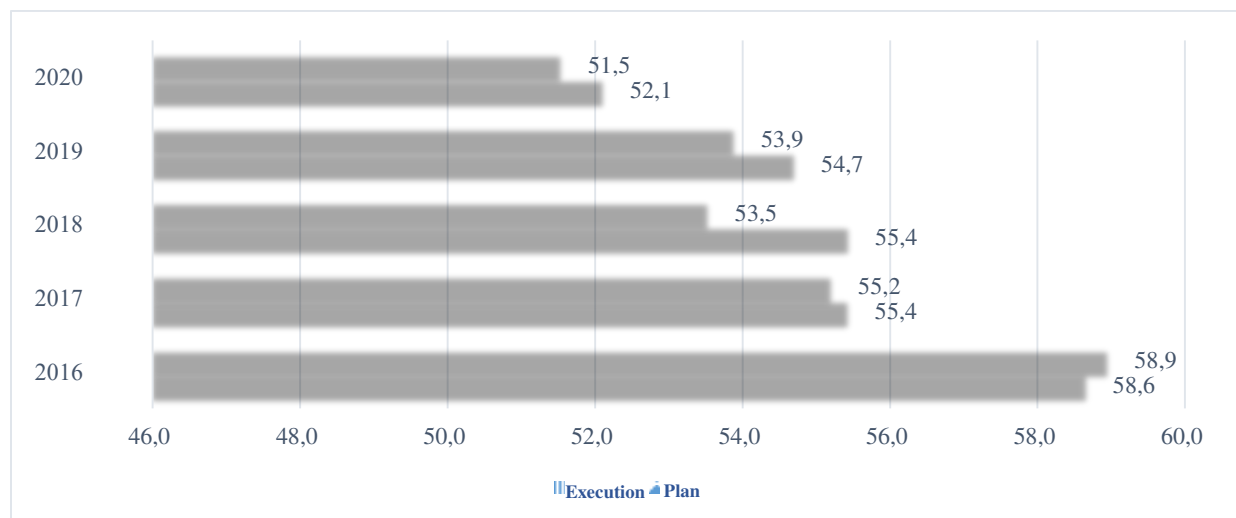

**Figure 3. Dynamics of the share of social expenditure plan and execution in the general state budget expenditure plan and execution<sup>6</sup>**

As can be seen from Figure 3, the share of social spending plans and execution in the overall state budget expenditure plan and execution tends to decline. In particular, in 2016, the share of social expenditure plans and execution in the total state budget expenditure plan and execution was in the range of about 58-59%, while in 2020 this figure will be in the range of 51-53%. This may be due to an increase in the share of other costs, such as the health care system, due to the pandemic in 2020. Therefore, if we turn our attention to 2019, we can see that the share of social spending plan and execution in the total state budget expenditure plan and execution was 54.7 and 53.9 percent, respectively. This indicates that the share of social sector expenditure plan and execution in the overall state budget expenditure plan and execution is declining; If we pay attention to the execution of the budget expenditure plan, we can see various changes. In particular, the plan was implemented in 2016 only in the expenditures of public authorities, administration, justice, prosecutor's office and the judiciary with more than 3.5 billion soums, while by 2020 the plan of social expenditures, reserve funds and other expenditures was not implemented;

- If we analyze the types of expenditures that have experienced a sharp increase in quantity in the period 2016-2020, we can include in the structure of such expenditures the cost of financing reserve funds and centralized investments.

Expenditures of reserve funds in 2020 compared to 2016 increased by 13.7 times in the plan and 14.8 times in execution. The main reason for this is the increase in the cost of reserve funds in the Republic of Karakalpakstan, regions and the city of Tashkent from 2018, and the formation of a reserve fund in each of their districts and cities.

The cost of financing centralized investments, on the other hand, increased sharply in 2020, mainly due to the fact that many facilities were built due to the pandemic;

- In the period from 2016 to 2020, we can point to the costs of maintaining the self-governing bodies of citizens, as well as other costs, as the areas of expenditure that have seen a slower growth than other expenditures in terms of quantity. Expenditures for the maintenance of citizens' self-government bodies in 2020 compared to 2016 increased by 1.7 times, and the



implementation by 1.7 times.

Other expenses in 2020 compared to 2016 increased by 2.8 times in the plan and 2.7 times in execution.

## CONCLUSION

In general, such an increase in the plan and execution of budget expenditures will certainly increase the urgency of its disclosure. Because the main stakeholders in the increase in budget expenditures are, of course, citizens. Therefore, it is necessary to disclose as much as possible the cost directions, such as the undefined reserve fund or other expenses included in the category of non-disclosure, when planning the directions of use in the cost directions.

## REFERENCES

1. "Guide to the questionnaire for the assessment of the budget disclosure: the definition of questions and options for the selection of answers." Internet source: [www.internationalbudget.org](http://www.internationalbudget.org) Application date May 27, 2021.
2. Resolution of the President of the Republic of Uzbekistan No. PP-5147 "On measures to radically improve the activities of the Accounts Chamber of the Republic of Uzbekistan" August 10, 2017 <https://www.lex.uz/acts/3469455>
3. Information from the United Nations website ([unstats.un.org](http://unstats.un.org))
4. Resolution of the Cabinet of Ministers of the Republic of Uzbekistan No. 841 "On measures to implement national goals and objectives in the field of sustainable development until 2030" dated October 20, 2018. <https://lex.uz/docs/4013356?query=%D1%84%D0%B5%D1%80%D0%BC%D0%B5%D1%80%20%D1%82%D1%9E%D2%93%D1%80%D0%B8%D1%81%D0%B8%D0%B4%D0%B0%20%D2%9B%D0%BE%D0%BD%D1%83%D0%BD>
5. Mikhailova A.A., Klimanov V.V., Rabadanova A.R. The correlation of budgetary openness and transparency with the position of countries in the main international rankings. *Voprosy Ekonomiki*. 2018;(12):66-76. (In Russ.) <https://doi.org/10.32609/0042-8736-2018-12-66-76>
6. Yu.V. Belousov, O.I. Timofeeva, "On the methodology and results of the study of the level of openness of budgetary data of the constituent entities of the Russian Federation" *Financial jurnal* No. 3, 2015 <https://cyberleninka.ru/article/n/analiz-urovnya-otkrytosti-byudzhethnyh-dannyh-v-subektah-rossiyskoy-federatsii/viewer>
7. Yu.V. Krivorotko "Openness in the budgetary process in the Republic of Belarus" Minsk 2019 Prepared for the VET "Foundation named after Lev Sapieha "within the framework of the project" Budget of Civil Participation to Strengthen Civil Society and Local Self-Government" <http://sapieha.org/wp-content/uploads/2019/12/%D0%9E%D1%82%D0%BA%D1%80%D1%8B%D1%82%D0%BE%D1%81%D1%82%D1%8C-%D0%B2-%D0%B1%D1%8E%D0%B4%D0%B6%D0%B5%D1%82%D0%BD%D0%BE%D0%BC-%D0%BF%D1%80%D0%BE%D1%86%D0%B5%D1%81%D1%81%D0%B5-%D0%B2-%>
8. Information from the Ministry of Finance website (<https://www.mf.uz>)

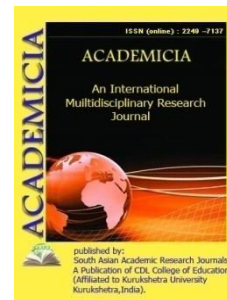
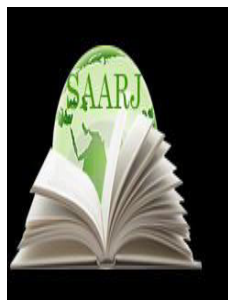

DOI: **10.5958/2249-7137.2021.01917.0**

## INFLUENCE OF CULTIVAR COMBINATIONS AND SEEDLING THICKNESS ON THE FORMATION OF PHYTOMETRIC INDICATORS AND PRODUCTIVITY OF PEAR TREES IN INTENSIVE ORCHARDS

Yunusov R\*; Nazarova S.M\*\*; Ganieva F.A\*\*\*; Ataeva Z.A\*\*\*\*

\*Associate Professor,  
Department of “Soil Science”, Candidate of Agricultural Sciences,  
Bukhara State University, UZBEKISTAN

\*\* Associate Professor,  
Department of “Soil Science”, Candidate of Agricultural Sciences,  
Bukhara State University, UZBEKISTAN

\*\*\*Teacher,  
Department of “Soil Science”, Bukhara State University,  
UZBEKISTAN

\*\*\*\*Teacher,  
Department of “Soil Science”, Bukhara State University,  
UZBEKISTAN

### ABSTRACT

*In this article is given the influence of varieties-rootstock combinations and planting schemes on the phytometric growth rates and fruiting of pear varieties grafted on a seedling C<sub>1</sub>-Williams, Abbat and Carmen. The most productive varieties of pear tree connected to the vegetative graft are Carmen, Abbat and Williams, planted in the garden on a 4.0x1.2 m scheme, with 2088 pear seedlings per hectare. The air exchange process is also improved. Sunlight, on the other hand, has a positive effect on the yield formation of small pear varieties, allowing the trees to increase their productivity during the growing season.*

**KEYWORDS:** *Fruit Growing, Intensive Pear Orchards, Dwarf Trees, Vegetative Rootstocks, Phytometric Values And Fruit Formation, Efficiency.*

## INTRODUCTION

Intensification of fruit growing in Uzbekistan to increase fruit production, i.e. the use of modern methods, deep development of the fruit industry, integration of production; increase the productivity and quality of existing orchards, create new modern, abundant and high-quality orchards instead of low and low quality ones; efficient use of mountain and foothill areas, complete and efficient use of methods such as irrigation and fertilization.

The expansion of the area of orchards will be built mainly for the purpose of expanding production on farms specializing in fruit growing. In the fruit-growing regions of the country, the Government of the Republic of Uzbekistan has set a task for the fruit industry to further increase the volume of fruit production to ensure the domestic market and strengthen the export potential.

The relevance of the topic of this scientific article is in the dramatic improvement of the abundant and high-quality yield and fruit quality of intensive orchards connected to the vegetative, ie, grafted propagated grafts of pear trees from intensively seeded fruits; The establishment of science-based orchards in the cultivation of quality pears is one of the most important issues.

## THE MAIN FINDINGS AND RESULTS

This field research was carried out in 2020-2021 at the horticultural farm of “SiyovushAgro” LLC, located on the territory of Bogikalon Farm, Bukhara district, and Bukhara region.

Bukhara region is located in the desert zone, and soil formation takes place in hot and dry climates. The climate of Bukhara region is sharply continental, with an average annual rainfall of 125-175 mm, mainly in early spring and winter. Hot sunny days last up to 240 days, during which time the average air temperature is 26-30°C. The hottest days are in the summer, with daytime temperatures ranging from 38.7 to 46.2<sup>0</sup>C and above in late June-early July. Winters are dry and cold: the average temperature in January ranges from 4<sup>0</sup> °C to 13<sup>0</sup> °C. The average relative humidity is 40-60%.

In terms of mechanical composition, clayey, heavy and loamy soils, consisting of 56.9%, account for 35.6% of lightly loamy soils and 7.5% of desert and sandy soils in the total irrigated area of the region. Layers of 0-125 cm and 200-250 cm are added with average loam soils, and layers of 125-200 cm form heavy soils. The volumetric weight of soils is 1.40 g / cm<sup>3</sup> in the 0-70 cm layer and 1.32 g / cm<sup>3</sup> in the 0-100 cm layer. [6.7].

The result of the study.

The most productive varieties of pear tree connected to the vegetative graft are Carmen, Abbat and Williams, planted in the garden on a 4.0x1.2 m scheme, with 2088 pear seedlings per hectare. The processes of growth, development and yield increase of pear trees are normal in the experimental garden. It should be noted that the protection of pear and apple trees from complex pests is carried out at the horticultural farm “Siyavush Agro” LLC with the strict participation and control of agronomists. The experimental garden is carrying out complex protective measures for 2020-2021, which will ensure the normal growth of pear trees and give a rich harvest and quality.

The branches are shaped in a semi-sparse manner. Pear orchards are fully irrigated by drip irrigation. It is watered through hoses during the day, saving water consumption 2-3 times. S1 is

the main graft for young pear trees. S1 grafts are the grafts used in many intensive weeds, and today this graft is also used in large weeds. In S1 grafting, the yield of pear tree varieties is high. It is harvested in 2-3 years after transplanting in the garden [4,5,8].

Low-growing deciduous trees are different from strong-growing deciduous trees. Pear trees attached to low-growing grafts are used more fully to form fruit buds and form a crop formed during the assimilation process. Our research shows that in gardens grown in low-growing shrubs, especially vegetative stunted shrubs, most carbohydrates are used to produce fruit elements during the growth and development process, and a relatively small portion is spent on tree and root growth.

The combination of varietal grafts and convenient seedling thickness, along with general high agro-technical care for the tree in intensive pear orchards, is its proper setting and formation, and this measure can sometimes be seen for several years.

According to modern notions, an intensive pear orchard is an orchard with an early harvest, high quality and stable yields every year, maximum use of technical means, low production costs and low cost of crops [1,3 , 5.7].

Currently, there is a lot of world practice and theoretical-practical materials on the cultivation of high-quality crops from intensive dwarf pear trees. In our studies, pears were also found in the Williams, Abbat, and Carmen varieties.

It should be noted that the pear, which is attached to the stunted vegetative grafts, in the Carmen, Abbat and Williams varieties, in 2020, 66% in the lower part, where the twigs are placed, and 72.0% in the middle part. Similar results were observed in experiments conducted in 2021, but it should be noted that as a result of the growth and development of pear trees, it was found that the percentage of light decreased by 2-4% along the tree tiers.

Pear varieties Carmen, Abbat and Williams, studied during 2020-2021, were selected from 10 typical trees for light study and were studied around indicators such as all conducted phytometric formation processes, yield and cost-effectiveness of fruit growing. In the experimental garden, he uses the method of drip irrigation through a series of hoses. Pear trees are pruned 2-3 times during the application period, taking into account the growth of weeds, 250 kg of nitrogen fertilizers, 150-180 kg of phosphorus fertilizers and 45-60 kg of potassium fertilizers are applied to the soil in one hectare of pear orchards.

Choosing the right and science-based care technology for pear trees, carrying out proper processing and pruning processes, choosing the optimal grafting and seedling thickness, and achieving uniform distribution of sunlight into the interior of the tree will result in better assimilation in stunted pear leaves. In 2021, 0.4-2.2 kg of quality was obtained from the average bush in the studied varieties.

## **CONCLUSION**

Based on the results of a study conducted at the “SiyavushAgro” horticultural farm in Bogikalon Farm, Bukhara District, Bukhara Region, it was found that sunlight spreads evenly into the branch system of scientifically based intensive pear trees, sharply reduces the number of complex diseases and pests. The air exchange process is also improved. Sunlight, on the other

hand, has a positive effect on the yield formation of small pear varieties, allowing the trees to increase their productivity during the growing season.

It should be noted that the connection of small pear varieties to vegetative grafts leads to an improvement in their phytometric performance, and as a result, the yield of pears in Williams, Abbat and Carmen varieties increases by 15-25% and fruit quality improves dramatically.

The results of the above scientific research also show that the correct shaping of intensive pear trees attached to stunted vegetative grafts, the use of modern economical drip irrigation method and taking into account the biological properties of pear graft grafts leads to increased productivity and drastic improvement of fruit quality.

## REFERENCES

1. Aripov A.U., Aripov A. A. (2013) Seed intensive gardens. – Tashkent. “Sharq”. – p. 156.
2. Yunusov R., Umarov K. (2007) Horticulture. – Tashkent. “National Society of Philosophers of Uzbekistan”. – p. 182.
3. Ganieva F.A. Yunusov R. (2021) Dependence of growth and yield on intensive diamonds in the conditions of Bukhara region on the thickness of seedlings and combinations of varietal grafts. – Bukhara: “Durdona”. – p. 102.
4. Ganiyeva F.A. Yunusov R. Studyina the different formations of apple tree in intensive orchards European journal of Agriculturae and Rural Education [EJARE] Ajjaitabe Online at. <https://www.scholarrest.com> Vol.2No4, April 2021.
5. Ganieva F.A., Yunusov R. (2021) Growth and development of vegetatively propagated apple rootstocks depending on planting density. – Moscow. <https://www.scientificcapital.ru>.
6. Yunusov R., Ganieva F.A. The effect of cutting method and levels on the leaf surface of the apple tree. Khorezm Mamun Academy. Information -4,2021. <https://journal.buxdu.uz/>.
7. Ganieva F.A., Yunusov R., Turaeva N.M. (2021) Growth and fruiting of peach trees in irrigated orchards, depending on the design of the crowns. J. “Capital of Science” - Moscow. <https://www.scientificcapital.ru>. (
8. Ganieva F.A, Yunusov R. Economical Innovative Basis For The Care Of Intensive Stunted Apple Varieties Asian Journal of Multidimensional Research (AJMR). 282-285 <https://www.tarj.in>. ISSN: 2278-4853 Vol 10, Issue 6, June, 2021 Impact Factor: SJIF 2021 = 7.699



**ACADEMICIA**  
**An International  
 Multidisciplinary  
 Research Journal**  
 (Double Blind Refereed & Peer Reviewed Journal)

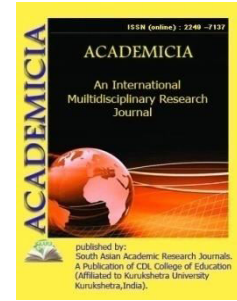

**DOI: 10.5958/2249-7137.2021.01918.2**

**THE ROLE OF THE LANGUAGE IN RAISING THE LEVEL OF  
 HUMANITARIAN TRAINING OF SPECIALISTS FROM TECHNICAL  
 UNIVERSITIES**

**Nargis Kudratkhodjaeva\* ; Nigora Giyasova\*\* ; Nigora Yusupova\*\*\***

\*Associate Professor,  
 The Tashkent State Technical University,  
 University street Tashkent city,  
 UZBEKISTAN

\*\*Senior teacher,  
 The Tashkent State Technical University,  
 University street Tashkent city,  
 UZBEKISTAN

\*\*\*Teacher,  
 The Tashkent State Technical University,  
 University street Tashkent city, UZBEKISTAN

**ABSTRACT**

*The article discusses the changes in the social, political, economic life of our country. In this regard, in a higher educational institution of a technical profile, a language should be considered as an obligatory component of the humanitarian training of specialists. The training of specialists of a high professional level should include not only the study of special technical sciences, but also the development of a spiritually rich personality with creative potential and high professional culture.*

**KEYWORD:** *Humanization, Technical Science, Development, Video Course, Discipline, Social, Sociocultural Connection, Special Method, Intercultural Communication, Significant Influence*



## INTRODUCTION

In the modern world of actively developing international contacts and ties in politics, economics, culture, language knowledge is becoming a real necessity. For employers of most large companies, a modern specialist is a professional in his field, familiar with world practice and fluent in one or more foreign languages.

The humanization of higher technical education is designed to ensure the development of individuality and personal qualities, in which a specialist in his life and work will take into account the needs, regulate and correlate his requests with the requests of society.

In a technical higher educational institution, a language should be considered as an obligatory component of the humanitarian training of specialists. An urgent problem of modern didactics is the need for a general activation of the learning process. One of the ways to achieve this goal is to include students in various activities that allow them to significantly increase their cognitive activity, the process of general development. One of the forms that can solve this problem to some extent is the use of a video course in language classes, which will help teach the language not as a sign system with a set of standard phrases, but to teach communication in language in professionally significant situations. It is necessary to interest students of technical specialties in foreign languages, where traditionally language is not considered the main, main discipline.

Working with video recordings allows us to give the process of language acquisition a communicative and cognitive character, since only video recordings give a combination of linguistic socio - cultural connections, which is inherent in situations of real foreign language communication. At the same time, it should be emphasized that viewing videos should not be quantitative, but qualitative. For this purpose, a special technique is being developed aimed at developing a full-fledged ability to perceive linguistic and socio-cultural material.

The global informatization of all spheres of public life is observed in the world community. Ways to improve the effectiveness of general education are being developed, large funds are being invested in the creation and introduction of new information technologies. The state of the economy, the quality of people's lives, national security and the role of the state in the world community depend on the level of information and technological development and its pace. In all developed countries and in many developing countries, there are intensive processes of informatization of education.

Unlike traditional lectures, practical and seminar classes, active forms and methods of teaching allow you to bring the educational process closer to reality, imitating professional activity. However, among the problems that are theoretically and experimentally solved by the methodology of foreign languages for special purposes, the main one is the problem of internal and external motivation in most non-language universities.

The introduction of various forms of communication using creative and innovative technologies, the development of the ability to clearly define situations and communication goals with their systematic implementation, the expansion of the creative and scientific potential of students within the framework of intercultural communication ensure the formation and development of a competent specialist who is able to adapt to the modern level and style of professional and personal communication.

When using video materials in language classes, two types of motivation develop: self-motivation, when the film is interesting in itself, and motivation, which is due to the fact that the student can understand the language being studied. The use of video materials arouses students' interest and positive emotions, which contributes to the development of linguistic interest and, undoubtedly, has a significant impact on the formation of a stable motivation to learn a language. The strength of the impression and emotional impact of video materials on students also contributes to strengthening motivation. Therefore, the main attention should be directed to the formation of student's personal attitude to what they saw. Successful achievement of such a goal is possible only, firstly, with the systematic display of video films, and, secondly, with a methodically organized demonstration. This brings satisfaction and gives you confidence in your strength and a desire for further improvement. It is necessary to strive to ensure that students get satisfaction from the film through understanding the language, and not only through an interesting and entertaining plot.

Students of technical universities are characterized by such psychological features as a technical mindset and lack of language flair, which is so necessary for an adequate perception of language realities. An important task of a language teacher is to create real and imaginary communication situations in a language lesson using various methods and techniques of work (role-playing games, discussions, creative projects, etc.). It should be noted that the use of video materials in the lesson is not only the use of another source of information. The use of video contributes to the development of various aspects of students' mental activity and, above all, attention and memory. During the inspection of the video material, an atmosphere of cognitive joint activity arises. In order to understand the content of the video, students need to make an effort. Thus, involuntary attention turns into arbitrary attention, and the intensity of attention affects the process of memorization, the use of various channels of information receipt (auditory, visual, motor perception), positively affects the strength of capturing regional and linguistic material.

The proposed method of working with video material is as follows:

- 1) Teaching students to perceive the information they see in an organized and conscious manner;
- 2) Development of students' ability to observe, classify, select, and also put forward a hypothesis on the proposed materials;
- 3) Teaching students to analyze and summarize the information received;
- 4) Perception and statement of oral conclusions in an authentic way;
- 5) the correct presentation in the studied language of the idea contained in the material being shown, taking into account those socio-cultural norms that take place in foreign language communication, the ability to critically treat the video materials seen.

Thus, the psychological features of the impact of video materials on students contribute to the intensification of the educational process and create favorable conditions for the formation of students' communicative competence. The method of using videotapes includes three stages of work: interrogation, viewing and post-viewing. At the same time, special tasks are performed that require students to concentrate their attention.

Practice has shown that viewing video materials, which ends only with the exchange of impressions about what they saw, is not methodically correct. Most of the information with this approach remains not perceived by students.

A set of exercises designed for this purpose is of particular importance. They are both universal and indicative in nature. Much attention is paid to the exercises of psychological preparation for the perception of information, the development of the ability to analyze linguistic and socio-cultural information, as well as to improve the reproductive and productive speech activity of students.

When analyzing the students speech output, the following factors are evaluated: the time of completing the task; the total number of words in the presentation of the vocabulary relative to the original of the video material seen; the degree of understanding of the position of the heroes of the video materials; the degree of understanding of socio-cultural realities; the percentage of damage to the reproduced information.

The set of exercises also depends on which genre of video materials is used in each specific case.

In video materials, as well as in texts, information about the language is present in a hidden form: it does not say about the rules of the language, it is not proposed to work out phonetic phenomena and grammatical structures, etc. However, all these tasks are potentially possible; they are provided by the creators of educational films and, as with the use of texts, are introduced into the educational process before and after watching the film.

It is necessary to pay attention to the purpose of using video materials in the process of teaching the Russian language (teaching listening or speaking). When working on listening, the focus is on the sound series of video material containing oral speech presented for listening. When working on speaking, the visual series falls into the focus of students' attention and its possibilities of providing motivation and purposefulness of oral speech based on this visual series are evaluated.

In the case of working on speaking, an auxiliary is a sound series that can be used or not used at all, used fragmentally, only in certain cases.

In the case of working on listening, the visual range is also taken into account. For example, you should pay attention to the extent to which sound-visual synthesis is provided, which allows you to understand the audible through the visible. Nevertheless, the visual series is auxiliary, and the sound series is the main one.

To maximize the assimilation of the video material used, it is necessary to create special conditions that contribute to its better perception and understanding. Thus, we can distinguish the following methods of working with video materials.

1. The possibility of repetition (these may be key scenes, as well as places that are difficult to perceive).
2. Separation of information perception channels:
  - watch a movie without sound;
  - listening to a movie without an image.
3. Working with a freeze frame.

Video materials offer informative information on various topics. Their selection is determined by their accessibility for understanding at each stage of training, compliance with the life experience and age of students of the Russian language. The facts and phenomena are selected, which in their totality not only provide the disclosure of the topic, but also serve as the basis for independent thematic statements of students. The educational goal with video materials is to involve them in a critical dialogue about the film. This can happen on the basis of questions about the content of the speech, the situation described in the film, regional or thematic issues.

The advantage of this form of training is that it is suitable for independent work of students. In the domestic pedagogy of higher education, it is widely believed that traditional forms of classes (practices) should be replaced by such forms that provide individualization of learning (i.e., independent and individual work). However, for full-fledged independent work of students, well-equipped video libraries, linguistic laboratories and rooms for independent work are necessary.

It should be noted that at present, the volume of humanitarian disciplines for students of technical specialties is not much less than the volume of special disciplines. However, if the special disciplines that form professional knowledge are based on a solid foundation of natural science and general professional disciplines, then the disciplines of the humanities cycle, namely the Russian language, are taught throughout the year. Of course, this is very small.

Due to the current economic situation, it becomes necessary to provide the student with the opportunity not only to choose the discipline he is interested in, but also to determine the degree of depth of familiarization with it. Humanitarization as a new direction of work of technical universities is not without difficulties being implemented in life and requires genuine enthusiasts. Thus, the formation of a high humanitarian culture of future specialists is the dictate of the time.

## REFERENCES

1. Yakobson P. M. Psycholinguistic problems of human motivation. - Moscow, 1969.
2. The human factor in language: Linguistic mechanisms of expressiveness. Moscow: Nauka, 1991.
3. Gudkov D. B. Theory and practice of intercultural communication. - M.: Gnosis, 2003.
4. Kudratkhodjaeva, N. A., Usmonova, O. Y., &Usmonova, Z. N. (2020). Issue Of External Sema In Uzbek Language. The American Journal of Social Science and Education Innovations, 2(10), 297-302.
5. Yuldashevna, U. O., &Akbarovna, K. N. MODERN INNOVATIVE METHODS OF TEACHING RUSSIAN.
6. Yuldashevna, P. S. INNOVATIVE WAYS OF TEACHING RESEARCH FOR ESL.
7. Yuldashevna, R. N. (2020). THE ROLE OF THE FAMILY SOCIAL INSTITUTE IN THE DEVELOPMENT OF SOCIETY. Europeansciencereview, (3-4).



**ACADEMICIA**  
**An International  
 Multidisciplinary  
 Research Journal**  
 (Double Blind Refereed & Peer Reviewed Journal)

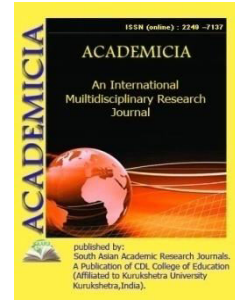

**DOI: 10.5958/2249-7137.2021.01920.0**

**THE IMPERATIVES FOR VOCATIONAL AND ENTREPRENEURIAL  
 EDUCATION: THE NYSC PERSPECTIVE**

**Brig. Gen. Shuaibu Ibrahim\***

\*Assoc. Prof, Department of History and War Studies,  
 Nigerian Defence Academy Kaduna,  
 NIGERIA

**ABSTRACT**

*With the growing rate of unemployment in Nigeria, there have been concerns as to how it can be abated. An important direction towards solving this problem is through Vocational and Entrepreneurial Education. This study examines the need for vocational and entrepreneurial education in the face of limited 'white-collar jobs'. The paper takes a cursory look at the history of vocational and entrepreneurial education in Nigeria. It also examines Vocational and Entrepreneurial Training of the NYSC Skill Acquisition and Entrepreneurship Development (SAED). It considers some of its marked achievements, as well as shortcomings. It also offers some important recommendations including the proposal that Vocational and Entrepreneurship Education be prioritized at the grassroots of the education system, preferably at the primary level.*

**KEYWORDS:** *Vocational Education, Entrepreneurial Educations, NYSC, Unemployment, White Collar*

**INTRODUCTION**

In the second quarter of 2020, the total number of unemployed educated Labour Force in Nigeria spiked to over 23.9 million people with an estimated unemployment rate of 27.1% (NBS, 2020). This places Nigeria amongst the top 50 countries with the highest unemployment rate in the world (NBS, 2020). The surge in unemployment is no doubt the direct consequence of the coronavirus pandemic, which has made it difficult for the nation's economy to keep up with its teeming population (Olurounbi and Soto, 2020). For years, the population growth rate in Nigeria has outpaced economic output, making it the country with the highest number of poor in the world (Olurounbi and Soto, 2020). According to the United Nations, Nigeria has a fertility rate of five children per woman and may become the third most populous country in the world by



2050, which may further compound the problem of unemployment (UN, 2019). Recently, the number of people looking for employment through Nigeria's biggest recruiting website Jobberman Ltd has jumped five-fold since the start of the Covid-19 pandemic in early 2020 (Olurounbi and Soto, 2020). This grim reality is forcing the hands of the government and several policymakers to rethink better ways of addressing the problems of unemployment in the country. As a result, there have been calls from several quarters to diversify the Nigerian economy and encourage entrepreneurship and vocational training at the various levels of education in the country. This is important because of the crucial role of the informal sectors in the Nigerian economy. For instance, 41% of the labour population with a bachelor's degree is without employment compared to only 18% for people with vocational skills(NBS, 2020).

Interestingly, the unemployment rate for people with vocational skills is also lower than people with master's (23%) and doctorate degrees (23%)(NBS, 2020).This implies that there could be more vocational job opportunities than white-collar jobs in Nigeria giving the large size of the informal economy, where most blue-collar jobs operate. Also, it means that a university degree is not a guaranteed route to paid employment. In most of its national development plans, education has always been treated as an instrument for socio-economic development in the policy thrust of the Federal Government of Nigeria, however, existing conditions in the tertiary institutions do not reflect the required level of commitment deserving of such imperative concern. Since the Memorandum on education policy in British Tropical Africa was issued in 1925, vocation and technical education have evolved to become a more convoluted part of the Nigerian educational curriculum. To encourage self-reliance among young graduates, the National Youth Service Corps (NYSC) which was established in 1973, formed an active partnership with the National Directorate of Employment in the 1980s and has continued to integrate skill acquisitions and vocational training as a vital part of its youth empowerment programmes, with the most recent being the Skill Acquisition and Entrepreneurship Development (SAED) Programme. This paper is therefore, an advocacy for vocational and entrepreneurial education as an imperative for reducing unemployment and creating more job opportunities for graduates by exploring the successes of the NYSC skills and vocational programmes in the face of dwindling White-Collar jobs.

### **Conceptual Clarification**

#### **White Collar:**

Hayes(2019) describes a white-collar worker as belonging to a class of employees known for earning higher average salaries doing highly skilled work, but not by carrying out manual labour at their jobs (para. 1). White-collar workers are usually associated with the "shirt and tie" set of workers who typically work in large spaced offices and companies. White-collar jobs are usually defined by office jobs and management, and not "getting their hands dirty" (Hayes, 2019) with fat salaries at the end of the month. This class of workers stands in contrast to blue-collar workers, who traditionally wore blue shirts and works at vocational plants, mills, and factories. White-collar work used to mean a high level of education and the assumption of securing a comfortable job with special privileges and remunerations (Hayes, 2019).Typical white-collar jobs include company management, lawyers, accountants, financial and insurance jobs, consultants, and computer programmers—among many others. White-collar positions are often expected to offer opportunities to advance to more significant roles as managers or executives. A white-collar role is likewise expected to generate higher paying salaries with the potential to



continue to rapidly scale up their income with further advancement (Hayes, 2019). In this regard therefore, attorneys, accountants, architects, bankers, real estate agents, business consultants, and brokers are often described as white-collar positions. Though the actual work performed typically is not menial, white-collar roles can require the professional to commit to extensive hours during the workweek, and sometimes on weekends because they are more, or less, office based (Hayes, 2019).

### **Vocational Education:**

Vocational Education refers to the type of education that is aimed at equipping individuals to use their knowledge and hands to survive in a world that is essentially work-oriented (Olanipekun et al, 2015). Akpan et al (2012) describe it as a workshop – based education, which is concerned with the methods of processing materials using tools and equipment, into products of economic value (p.2). It also involves the provision of services as in home economics, health occupations and other service areas (Akpan, 2012). In this light, vocational education holds the key to national development. The key motivation that drives Technical and Vocational Education is basically to enhance human dignity and enthrone work and labour by making individuals acquire and/or develop enough saleable and employable skills, competencies, attitudes as well as knowledge to enable them to gain and maintain basic employment or self-reliance for a comfortable living (Olanipekun et al, 2015). Abdulahi as cited in Olanipekun et al(2015), sees vocational and technical education as that aspect of education that involves the acquisition of techniques and application of the knowledge of science for the improvement of man's surrounding. The major goal of technical and vocational education is to prepare the individual for the world of work empowering such individual to become reliant and make contributions to the general development of the society. Eru (2007) maintained that Vocational and Technical Education is an education designed for experts in the field of education to prepare individuals to acquire practical skills, basic and scientific knowledge and attitude required as craftsmen and technicians at sub-professional and even professional level.

### **Entrepreneurship**

Over the years, entrepreneurship has become a near-obsessive term used by several advocates of capitalist orientation to describe the pursuit of wealth creation through the utilization of opportunities wherever they may abound (Gartner and Birley, 2002). As such, entrepreneurship lacks a generic definition. Shane (2003) describes entrepreneurship as the act of being an entrepreneur, and an entrepreneur is said to be “someone who perceives an opportunity and creates an organisation to pursue it” (Bygrave and Hofer as cited in Gartner and Birley, 2002, p. 14). Entrepreneurship has developed over the past decade and a half, to described ventures closely associated with risk-taking, astounding innovations and creativity in its service provision and product manufacturing. Entrepreneurship has been extended to cover such areas as socio-cultural, political, and educational forms of entrepreneurial activity (Olorundare and Kayode, 2014). In the context of education, entrepreneurship is targeted at three important goals. These are: to help learners to understand entrepreneurship, entrepreneurial activities and learn to help them become an entrepreneur (Hytti, as cited in Olorundare and Kayode, 2014). In contemporary time, any individual industry, or business leader with innovative and creative business abilities is described as an entrepreneur or someone who engages in entrepreneurship (Okala as cited in Olorundare and Kayode, 2014). The entrepreneur explores the available opportunity for wealth creation by venturing into the business of organising and managing human and natural resources

towards targeted goals. In a nutshell, the entrepreneur perceives a business opportunity and takes advantage of the scarce resources to profitably meet with unlimited opportunities (Olorundare and Kayode, 2014).

Entrepreneurship is a risky venture. The entrepreneur bears non-insurable risks and directs human and material resources to achieve economic, social, and financial goals of the enterprise (Olorundare and Kayode, 2014, p.158). Several authors have described Entrepreneurs as Adam Smith and Robert Cantillon in the late 17th and 18th centuries respectively, observed that the entrepreneur is an actor in macroeconomics but the study of entrepreneurship was ignored theoretically until 19th and 20th centuries, and empirically until a profound resurgence in business and economy in the last 50 years (Olorundare and Kayode, 2014, p.158). The understanding of entrepreneurship was not clear until the 20th century. This giant leap is credited to the works of economist Joseph Schumpeter in the 1930s and other Austrian economists such as Carl Menger, Ludwig Von Mises and Friedrich Von Hayek (Olorundare and Kayode, 2014). Most credit goes to Schumpeter who described the entrepreneur as a person who is willing and able to convert new ideas or invention into a successful innovation (Schumpeter, as cited in Olorundare and Kayode, 2014, p.158).

### **Historical Development of Vocational and Entrepreneurial Education in Nigeria**

Vocational education has been an important part of human societies for centuries (Roberts, 1971). It remains the oldest form of education in many parts of the world. In most African societies, occupations of individuals are first bequeathed to them by their families and closest relations (father to son or mother to daughter or uncle to nephew etc.). This was known as home apprenticeship system (Akpan et al, 2012). Little wonder then that a potter's child often becomes a potter and a blacksmith's son a blacksmith. In different cultures, it took unique approaches which allowed people to find work and satisfy their daily needs as well as cope with their physical environment (Akpan et al, 2012). In traditional Nigerian communities, vocational education was ingrained in the system of the people long before the coming of the Europeans and colonialists. Often, the type of vocations and occupations found in the various regions was greatly influenced by the geographical nature of the areas. Some of the most prevalent vocations were weaving, sculpting, blacksmithing, carving, farming, fishing, cattle rearing, hair plaiting, dressmaking, bead weaving, leatherwork, pottery, brick making, basket weaving, raffia works, mat weaving etc.

The coming of colonialism deemphasized some traditional systems in favour of foreign ones. For instance, to promote administrative and economic conveniences, most colonial policies on education were mostly tailored to churn out workers that are essentially needed to support missionaries or European administrators (e.g. catechists and clerks) (Fafunwa, 1995). As a result, vocational education was not given a meaningful place in the educational system. Consequently, educated people were those who majored in classics like, English, History, Latin, Greek, Milton and Shakespeare etc. Most of the earliest Nigerian scholars were famous for their literary erudition or "much book learning" (Fafunwa, 1995). Things would remain the same until 1909 when some form of vocational education programmes were introduced in the Nassarawa School of the then Northern Region (Akpan et al, 2012). The Nassarawa School opened in 1909 had a technical wing, which offered training in leatherwork, carpentry, black-smithing, weaving and bookbinding (Akpan et al, 2012). Other early attempts at encouraging vocational education in

Nigeria include Boys' Vocational School, Ididep, Ibiono-Ibom in present day AkwaIbom State of Nigeria and Blaize Memorial Industrial School in Abeokuta (Akpan et al, 2012).

As nationalist fervour began to grow in many West African colonies in the years preceding the First World War (1914 – 1918), colonial administrators began to make some major changes to keep the locals content. It was at this time that the Memorandum on education policy in British Tropical Africa was issued in 1925. The policy statement invited governments to take a more active part in the provision of technical education, which required more costly equipment and suitably qualified staff (Nduka, as cited in Akpan et al, 2012). Following this development, the government began to open trade centres and technical institutions, and by 1934, the Yaba Higher College was established. Following the demands of the memorandum which requested that the colonial government in the colonies create departments for training technicians, the government began to draft curriculum that was more technical and scientifically based. A major goal was to provide requisite skilled force for the Public Works Department, the Post and Telegraph Department, the Department of Agriculture, the Nigerian Railways and other commercial and industrial ventures.

The first set of students admitted to Yaba Higher College took courses in engineering, medicine, education and agriculture (Akpan et al, 2012). By 1946 when the ten-year development plan was put forward, it was recommended that vocational/technical education be given more attention to meet the growing demands for technicians and craftsmen in the colony. As a result, 14 craft centres were established in the North, 9 in the East, and 2 in Lagos (Akpan et al, 2012). The education given at Yaba College was mainly vocational that led to the award of the college diploma and guaranteed that there is constant availability of technicians and craftsmen to handle emerging industrial and technical challenges (Akpan et al, 2012). By 1952, technical institutions were found in Yaba, Enugu and Kaduna, while several other trades and handicraft centres were scattered all over the country.

In 1953, the first Nigerian College of Arts, Science and Technology was established in Zaria, followed by similar establishments in Enugu and Ibadan. These colleges offered courses in mechanical, electrical and civil engineering, telecommunication, and agriculture (Akpan et al, 2012, p.4). Eventually, most of these colleges would be upgraded into the status of a university. The University of Nigeria, Nsukka offered the first organized Vocational – Technical Education (VTE) programme in West Africa. The publication of the Ashby Commission Report in 1960 recommended the introduction of technical streams in the secondary schools and three levels of technical education in the country namely: 1. Pre-vocational and Pre-technical levels of training for secondary schools; 2. Craftsman training for technical colleges, trade centres and vocational schools; 3. Technical training for Polytechnics and Colleges of Technology (Fafunwa, as cited in Akpan et al, 2012, p.4).

The first National Policy on Education was outlined in 1977 by the Federal Government, granting a more robust ground for the development of vocational education in the country since its inception. This policy was reviewed in 2004 and strove to achieve the five goals, which targeted technological development in Nigeria. To achieve these ambitious goals, the government set up agencies for effective monitoring and evaluation of the programmes. These agents are the National Commission for Colleges of Education (NCCE), the National Board for Technical Education (NBTE) and the National Universities Commission (NUC). Each agency outlines the minimum expected standards of operation by the training institutions (Akpan et al, 2012).

In 2005, the National Council on Education (NCE) approved a new curriculum structure namely: lower basic education curriculum (primaries 1-3), middle basic education curriculum (primaries 4-6), and upper basic education curriculum (JSS 1-3) with subject listings (Akpan et al, 2012). Also, the Nigerian Education Research and Development Council (NERDC), was mandated to restructure the curriculum with the following objectives in view: Develop interest in science and technology; Acquire basic knowledge and skills in science and technology; Apply their scientific and technological knowledge and skills to meet the needs of the society; Take advantage of the numerous career opportunities offered by science and technology; and become prepared for further studies in science technology (Akpan et al, 2012). In 2006, the Federal Government directed Nigerian Higher Education Institutions (HEIs) to include entrepreneurship Education (EED) as a compulsory course for all students with effect from the 2007/2008 academic session (Aliu, 2008). This led to the inclusion of EED in the curriculum of all universities and other higher education in Nigeria. Most of the universities in Nigeria now have a centre for entrepreneurship education in their respective institutions.

### **Vocational and Entrepreneurial Education —The NYSC Perspective**

The years that followed Nigeria's Independence came with a lot of turbulences. As the British left the shores of the country, the different regional governments tore at each other with such fierce cynicism that it was impossible to believe in the nation's continued existence. From the Federal Census Crisis of 1962 through to the Western Election Crisis of 1965, Nigeria's unity hung on a thin line. By December 1965, things had gotten worse, and in an attempt to salvage what was left as the military claimed, Major Chukwuma Kaduna Nzeogwu carried out a military coup on 15<sup>th</sup> January 1966 leading to the death of some prominent Nigerian leaders including the Prime Minister of the federation. The ripple effects of these unfortunate events culminated into a Civil War that lasted from 1967 to 1970. At the end of the war, the Gowon administration introduced some important policies and programmes that were targeted at helping the nation heal faster. It was in this spirit of unity that the National Youth Service Corps (NYSC) was introduced on May 22<sup>nd</sup>, 1973.

The NYSC was established by Decree 24 of 1973 (NYSC, 1999). This Decree was later revised to Decree No. 51 of 1993 and enacted as an act of parliament in the NYSC ACT, Cap. 84 of 2004 (NYSC, 1993, 2004) and is under the oversight of the Federal Ministry of Youth Development (FMYD, as cited in Arubayi, 2015, p.83). According to the decree, the establishment of the National Youth Organization was designed to develop young persons in simulated work conditions. The primary aim of the organization is to provide appropriate training in various skills in real working conditions, while inculcating a healthy attitude towards manual labour. The [NYSC] Corps was designed to be a project-oriented learning programme with a focus on deploying grassroots projects in rural communities involving the building of roads, bridges, schools and dispensaries (FRN, 1970, p.261). The NYSC scheme has four cardinal programmes and they include Orientation, Primary assignment, Community Development Service and Passing Out.

During the Youth Orientation and Induction Programme, skills acquisition and entrepreneurship development programmes, language seminars, socio-cultural and traditional lectures, development workshops, career mentoring programmes and religious activities are offered together with Man-O-War paramilitary training (NYSC, 2011). The expected outcomes of participating in these activities are to increase self-discipline and opportunity for ethnic

interaction; reduce the fear of the unknown, enhance knowledge of the country's development agenda, and imbibe the culture of professionalism (NYSC, 1983, 2007, 2008).

For the last three decades, the major focus of Youth Service Schemes all over Africa have concentrated on Youth empowerment through vocational and entrepreneurship training. According to UNECA African Youth Report (2011):

The need to invest in human capital through education and skills development for young people remains of paramount importance...because of the return on education and the contribution to poverty reduction and achievement of the MDGs... Young people need an enabling environment politically, economically and socially to thrive in our countries. They need to be empowered so that they can be represented and participate in decision-making processes that affect their lives (p.viii).

In 2012, the Federal Government of Nigeria introduced a training programme into the NYSC known as the Skill Acquisition and Entrepreneurship Development (SAED) project (Deboom et al, 2020). The Project was targeted at promoting vocational skill acquisition amongst corps members as a panacea for graduate unemployment and underemployment in Nigeria. The SAED project operated on the mandate of providing youth corps members with open access to the acquisition of requisite and essential skills needed to make them successful entrepreneurs (Deboom et al, 2020). The Skill Acquisition and Entrepreneurship Development (SAED) as a Department in NYSC is headed by a Director and is made up of two divisions namely: Skills Acquisition Division and Entrepreneurship and Empowerment Division. According to Deboom et al, (2020) these two departments are saddled with the responsibilities of:

- Giving orientation and training to over 200, 000 corps members for skill acquisition yearly.
- Assisting the training and tutoring of 100, 000 young graduates in skill acquisition and entrepreneurship development for self-reliance annually.
- Developing an entrepreneurship partnership aiming towards self-reliance of the youths between the private sector and the public sector as well.
- Providing new ways and methods on how best Nigerian youths' employment and empowerment are done.
- Supporting evidence-driven funding programmes to formulate policies that enhance youth Nigerian youths' employment and empowerment.
- Organising orientation training programmes on the importance of corps members to enrol into the skill acquisition and entrepreneurship development program.
- Developing a standard curriculum for the in-camp skill acquisition exercise.
- Identifying organizations at the state level to provide training and mentoring in specific skills sets.
- Attaching the corps members to the various organizations for skill acquisition and entrepreneurship development.



- Monitoring and supervising trainee corps members and
- Facilitating access to available funding opportunities.

Currently, the NYSC scheme seeks to develop life skills and build on economic philosophies that are targeted at skills acquisition and entrepreneurship, which challenges youth corps members to become more 'self-reliant' so that they can be: independent and entrepreneurs; resourceful and have initiatives; and become employers of labour (Arubayi, 2015).

The SAED program has an ambitious vision to enable the creation of at least 20,000 sustainable enterprises annually, and get a minimum of 150,000 corps members to be productively engaged, generating sustainable economic value through employment or entrepreneurship, annually, in these sectors: Power and Energy; Information & Communication; Education; Agro-Allied; Culture & Tourism; Construction; Film & Photography; Food Processing & Preservation; Beautification; Education; Cosmetology; and Automobile.

The SAED policy is one of the few outstanding vocational and entrepreneurial policies in the country that is impacting on youths 'vocational productivity (Deboom et al, 2020). In the course of the 2012 Batch "B" orientation, the NYSC SAED empowered about 45,000 corps members with requisite vocational skills (Utomwen, 2012). Out of this SAED trainee, 5,404 corps members were trained in agro-allied skills, 5,509 corps members enrolled in food processing and preservation, 8,035 were trained in culture and tourism-related skills while 5,062 participated in cosmetology (Deboom et al, 2020). Furthermore, over 8,000 corp members were empowered in Information and Communication Technology (ICT). Under power and energy a total of 8,119, and 2,672 trainees were trained (Deboom et al, 2020). Since its inception, The NYSC-SAED programme has impacted not less than 971,272 corps members through its skill acquisition programme, while over 7000 have established their preferred business (This Day, February 6th 2019 as cited in Deboom et al, 2020). In 2014, about 159,732 corps members had completed the NYSCSAED programme which comprises of 69,904 females and 89, 828 males. Over 500, 000 corps members have been trained under the NYSC-SAED program since its inception (Deboom et al, 2020, p.149). According to a report in its official website, the Scheme reported that out of the total number of trained entrepreneurs, 1,600 had become full-time entrepreneurs (NYSCSAED, as cited in Deboom et al(2020).

Ekezie and Deebom (2019) researched extensively on the impact of the NYSC SAED programme and reported that Skills such as Snail Production, Cat Fish Production, Broilers Production, Layers/Egg Production, Fashion Designing, Hat Making, Tie & Die Ankara, Tie & Die Ankara, Perfume Making, Electrical Installation, Solar Installation, and Cosmetology offered by the NYSC-SAED programme has helped to empower youth in Rivers State. With the realization that the NYSC vocational and entrepreneurial training programmes have a scalability prospect, the Nigeria Bank of Industry, the Central Bank of Nigeria amongst other corporate organisations across the country partners with the NYSC management team to help Corp members to develop relevant skills that can improve their potentials of becoming employers of labour. Through the NYSC initiative, the Bank of Industry has recently made available some loans to enable Corp members to start-up businesses to create employment (Okpala, 2017).

### **Challenges with the NYSC Model of Vocational and Entrepreneurship Training**



While the NYSC's SAED programme maintains that it has trained over 600,000 corps members since its establishment as at 2016, only a little over 1,600 of the half a million trained have gone on to become full-time entrepreneurs (Umeh, 2015). This represents a 0.32 per cent success rate, which is lower compare to its ambitious mandate. In 2019, there were calls from some quarters, mostly among some serving Corps members to end the programme (Adenekan, 2019). This can be attributed in part to the conflict of ideology SAED programme creates (Umeh, 2015, para. 3). The primary objective of SAED is wealth creation through various vocational pieces of training that are expected to turn corps members into entrepreneurs. The major goal of the department is to teach graduates how to generate wealth in a nation that is riddled with unemployment. At the heart of this irony is that a good number of the graduates had gone to the university to increase their prospects of getting white-collar jobs only to be told that their various orientation camps that what they did not need a degree for was what they might spend the rest of their lives earning from. Some in university communities also feel uneasy by the NYSC's SAED programme, which looks upon their products as potential bead makers, cobblers, bakers, and makeup artists (Umeh, 2015, para.11).

Similarly, the NYSC vocational and entrepreneurship programmes may possess a lot of value, but the challenge, like other policies in the country, is with its implementation. Reported in the Premium Times article of May 23<sup>rd</sup> 2019, Chukwuyem Divine, a corps member in Abuja, described NYSC SAED as a great initiative with poor implementation:

The idea of the NYSC SAED programme is great but the implementation is poor...I will not blame my fellow corps members who called the initiative a scam due to so many irregularities I can attest to. I boycotted the training not because I am certain of a white-collar job after my youth service, but because of the clear exploitation, lack of professionalism of the trainers and the wrong timing. Most of our SAED lectures usually hold for three hours or more after intense morning parade when corps members must have been tired." (Chukwuyem Divine as cited in Adenekan, 2019, para. 6-9)

Also, the programme lacks a long term plan for participants and the necessary linkages needed to ensure that most of the corps members who pass through the training have enough support to help them stand on their feet after their service year. This strategy will ensure that the NYSC carryout regular impact assessment of the programmes on corps members to determine success, or failure rates. This may help answer some pertinent questions, one of which may include the argument that if the programme is as effective as the Youth Scheme appraised, why is the unemployment rate among graduates still rising?

Furthermore, the SAED scheme seems to be focused on specific skills that may not have great potentials for good profitability in the market. This is owing to either product oversaturation, or low demand for such services. Good examples are liquid soap making, makeup artistry, Beautification, Food Processing and Preservation, amongst others. Some Vital programmes like ICT may require more than the time available during the orientation camp to achieve a meaningful level of proficiency. What is often noticed in orientation camps is that the officials of SAED often make do with the skill-set of facilitators often drawn from the community of the camping corps members. Similarly, Zite and Deebom (2017) concluded that

the key challenges of the NYSC-SAED and its vocational training are; lack of qualified training instructors and lack of training facilities.

### CONCLUSION

This study examined the growing challenges of unemployment amongst graduates and the need to scale up vocational and entrepreneurship education in the country with reference to the NYSC vocational and entrepreneurship training programme under the NYSC Skill Acquisition and Entrepreneurship Development (SAED). The paper took a cursory look at the history of vocational training in Nigeria and concludes by recommending amongst other things, that Vocational and Entrepreneurship education must begin at the grass root levels of the educational system preferably at the primary level. It also assessed some of the challenges affecting the SAED, especially the duration given to the programme, which is not enough for the corps members to master the craft of their choice.

### Recommendation

1. Vocational and Entrepreneurship education must be prioritized at the grassroots of the education system preferably at the primary level.
2. Education is designed to meet the needs of society and not as a routine that must be maintained ritualistically. Therefore, the government should deemphasize and where necessary, stop the admission of students into humanities and some social science-based courses where there are already hundreds of thousands of graduates without jobs and increase the numbers of relevant vocational and science-based subjects that are relevant to the nation's economy in today's complex and digitalized world.
3. The SAED programme should be adequately funded and granted facilities across the nation to help in the efficient mentoring of graduate-trainees.
4. Vocational and Entrepreneurship training in tertiary institutions must deviate from theoretical-based practices to practical real-life-experiences and training that is targeted at problem-solving.
5. Tertiary institutions should create courses that are tailored along preparing graduates for a lifetime of experience in particular vocations and entrepreneurship endeavours.
6. The government should also consider opening mono-technics that are solely focused on offering definitive vocational and entrepreneurial careers to help young people make vocational choices at the post-secondary school levels.

### REFERENCES

- Adenekan, S. (2019, May 23). Corp Members Call for Review of NYSC Skills Acquisition Programme. *Premium Times*. Retrieved from <https://www.premiumtimesng.com/news/more-news/331316-corp-members-call-for-review-of-nysc-skills-acquisition-programme.html>.
- Akpan, G. A., Hogan S. U, King S. I. (2012).The Evolution of Vocational Education in Nigeria and Its Role in National Development. *The Intuition* Vol. 2 No. 1 Volume 2 no. 1.
- Arubayi, O.D. (2015). Youth in Development: Understanding the Contributions of the National Youth Service Corps (NYSC) to Nigeria's National Development .A thesis submitted to the University of Manchester on Degree of Doctor of Philosophy in Development Policy and

Management in the Faculty of Humanities. Institute of Development Policy and Management (IDPM).

Deebom T., Tambari, D., and Ilomabo T. D. (2020). The Influence of National Youth Service Corps Entrepreneurship Skill Acquisition Programmes on You them powermentin Rivers State. *International Journal of Humanities, Social Sciences and Education*.

Ekezie, A. I. A. and Deebom, M. T. (2019). Relevance of Vocational Agriculture Education on the Reduction Unemployment among Nigerian Graduates in Rivers State. *International Journal of Innovative Education Research*,7(2),75-84.

Eru, A.B. (2007). Challenges of globalization on vocational and technical education in Nigeria. Paper presented at the 3rd Annual Conference organized by School of Vocational and Technical Education, College of Education, Oju, Benue State, 14<sup>th</sup> -16<sup>th</sup> March.

Fafunwa, A. B. (1995). *History of Education in Nigeria*. Ibadan: NPS Educational Publishers Limited.

Gartner, W. B. and Birley, S. (2002). Introduction to the Special Issue on Qualitative Methods in Entrepreneurship Research. *Journal of Business Venturing*, 17 (5), 387-395.

Hayes A. (2019, Sep 27). White Collar. *Investopedia*. Retrieved from <https://www.investopedia.com/terms/w/whitecollar.asp#:~:text=A%20white%2Dcollar%20work%20belongs,%22getting%20their%20hands%20dirty.%22>

Lips-Wiersma, Marjolein, W., Sarah and Dik, B. (2016). Meaningful work: differences among blue-, pink-, and white-collar occupations. *Career Development International*.

NBS (2020) Labor Force Statistics: Unemployment and Underemployment Report (Q2 2020) National Bureau of Statistics (NBS) Abridged Labour Force Survey under COVID-19

Olawoyin, O. (2020, August 14). UPDATE: Nigeria's unemployment rate rises to 27.1% – NBS. *Premium Times*. Retrieved from <https://www.premiumtimesng.com/news/topnews/408790-nigerias-unemployment-rate-rises-to-27-1-nbs.html>

Olorundare, S., and Kayode, D. (2014). Entrepreneurship Education in Nigerian Universities: A Tool for National Transformation. *Asia Pacific Journal of Educators and Education*, Vol. 29, 155–175, 2014.

Olurounbi R. and Soto A. (2020 August 14). Nigeria Jobless Rate Climbs to Highest in at Least a Decade. Retrieved from *Bloomberg*. <https://www.bloomberg.com/news/articles/2020-08-14/nigeria-s-jobless-rate-climbs-to-highest-in-at-least-a-decade>.

Roberts, R.W. (1971). *Vocational and Practical Arts Education*. New York: Harper and Row Publishers.

Shane, D. (2003). *A General Theory of Entrepreneurship: The individual opportunity in Nexus*. *New Horizons in Entrepreneurship Series*. USA: Edward Elgar Publication.

Umeh K. (2015, July 10). Corps Members Undergo Entrepreneurship Training, Says NYSC. *The Guardian Newspaper*. Retrieved from <https://guardian.ng/news/corps-members-undergo-entrepreneurship-training-says-nysc/>

UNECA (2011). Africa Youth Report 2011: Assessing the Youth Education and Employment Nexus in the Global Economy. Addis Ababa: *UNECA*.

Utomwen, D. (2012, May). Tackling NYSC's Security Challenge. *PMNewsNigeria*. Retrieved from <http://www.pmnewsnigeria.com/2012/12/10/tackling-nyscs-security-challenge/>.

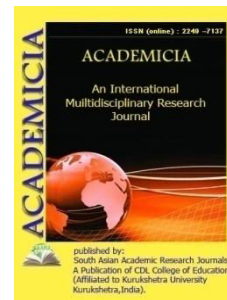
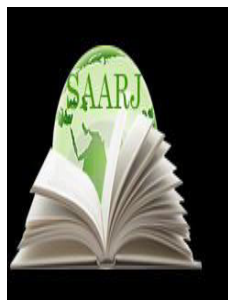

DOI: **10.5958/2249-7137.2021.01921.2**

## THE USE OF ANTHROPNYMS AND PSEUDONYMS IN ALISHER NAVOI'S GAZELLES

Gulruh Sohibbek qizi\*; Nargizaxon Rustamovna Umarova\*\*

\*An independent Researcher of Fergana State University,  
Department of Linguistics, UZBEKISTAN

\*\* Senior Lecturer,  
Doctor of Philological Sciences,  
Fergana State University, Department of Linguistics,  
UZBEKISTAN

### ABSTRACT

*In this article, the use of anthroponyms and pseudonyms in the works of the great poet Alisher Navoi, their examples show the time and place of use. This interpretation does not adequately express the essence of the nickname. The nickname is originally Arabic and means "to get rid of". It is also interpreted as "putting a second name in the poem other than one's original noun. It seems that anthroponyms have a certain place in the lexical system of the Uzbek language. Anthroponyms differ from other lexical units in their semantic, methodological, and constructive features. Such perceptions are associated with the misconception that the name is the essence of the person, the name is similar to the person.*

**KEYWORDS:** *Onomastics, Anthroponymy, Anthroponym, Lexical System, Nationality, Pseudonyms, Lexical Opportunity, Compliment.*

### INTRODUCTION

Anthroponymy is a branch of onomastics that studies the properties of human names. **Anthroponym** is a Greek word that means **anthropo-human**, **onim-nom**, meaning proper noun given to people. In Uzbek, the term is replaced by a name, a person's name, a person's name, a person's name.

Anthroponyms differ in the nature of the person (object) from which they are named. In this case, the anthroponym is divided into different types in terms of whether it is the name of a specific person who lived or has lived, whether it is a natural name, or whether the fabric is a

mythical name. This division is sometimes based on the source of the proper noun. Based on the above criteria, the following types of anthroponyms can be identified in the Uzbek language:

1. Real, that is, the famous name of living people.
2. The proper noun of the images.
3. Proper noun of legendary (mythological) people.

The names that make up the macro-scale of anthroponymy consist of the following nouns: Names, Nicknames, Surnames, Father's Names, Nicknames, and other historical forms of naming a person.

It seems that anthroponyms have a certain place in the lexical system of the Uzbek language. Anthroponyms differ from other lexical units in their semantic, methodological, and constructive features. Therefore, onomastic research should be carried out on a synchronous and diachronic basis in the historical-comparative method. Names have social significance and reflect the cultural and social life of the society. Names also refer to a person's lineage and place in society. Each name appears for a specific reason. It can be popular or less popular. They have the same name, their own history, "biography" and "geography". Names can be linguistically real or fictional.

Names can provide specific information about their object. This information has 3 views:

- Linguistic;
- Speech;
- encyclopedia.

As a unit of language, they name individuals, distinguishing individuals from one another. In verbal information, it is the speaker's attitude toward the name. Encyclopaedic information, on the other hand, approaches an anthroponym-based appellation meaning: Gulnara, Gulandom, Gulrukhsor are based on the semantics of delicacy and charm inherent in flowers. Names reflect nationality. Names can be old or new. There is a phenomenon of synonymy in names that move from appellators (To'xtasin, Tursun) but there is no polysemy. The phenomenon of synonymy is quite common. For example: Alpomish-Hakimbek, Majnun-Qays, Alexander-Iskandar, Sulaymon-Solomon. Apparently, anthroponyms are primarily words, and language is part of their richness. However, they also have a number of unique features.

In the gazelles, the anthroponym Alexander is given as Sikandar. In some places, there is a phenomenon of sound exchange.

The interest in anthroponyms and their study has a long history. Over the centuries, a number of anthroponymic studies have been created. The result was the science of anthroponymy. International onomastic conferences have been held in this field.

The step of independent Uzbekistan on a new path of social, economic and political development requires further improvement of the onomastic, including anthroponymic system. People believe that the name given to a baby has a great impact on his life, destiny and happiness. Such perceptions are associated with the misconception that the name is the essence of the person, the name is similar to the person. For this reason, there are various beliefs about the existence of "characteristic and non-characteristic" names in people's minds. The names of the Turkic layers



of the Uzbek language also have their own characteristics. They can be divided into the following groups:

**Name dedication (memories).** The following memorial names are found in the Turkic layer of anthroponymy of the Uzbek language:

- Names made up of celestial bodies: Yulduz, Oyxon, Kuntugmish.
- Made in the name of various natural phenomena and elements: Bo'ron, Yashin.
- Names made up of the names of different geographical objects: O'rmon, Daryo.
- Names associated with the names of animals and birds: Qo'chqor, Lochin.

Anthroponyms derived from the names of Turkic tribes and clans, these names include names derived from ethnonyms common to the Uzbek and Turkic peoples: Barlos, Dormon.

**Name wishes (desiratives).** These type names include:

- Parents name their children Ko'pay, O'lmas, Sobir to wish them a healthy growth and increase in number.
- They want the newborn to grow up well and join the family: Ilash, Koldosh, Yuldosh.
- The baby wants to replace his parents when he grows up: O'rin, O'tagan.
- They want their next child to be a boy, not a girl: O'g'ilyo.

Alisher Navoi's gazelle "Zihi husnung..." consists of artistic anthroponyms from beginning to end. It should be noted that the naming of the heroes of a work based on a historical figure or an artistic fabric in the composition of a ghazal creates the art of "talmeh".

Nicknames are one of the least studied layers of the Uzbek anthroponymic system. The term pseudonym in Russian means "**pseudonym**" in Greek. The Uzbek dictionary defines a nickname as follows: "A nickname is a second name chosen by an artist (poet, writer, painter, scientist, etc.) or a politician. This interpretation does not adequately express the essence of the nickname. **The nickname** is originally Arabic and means "**to get rid of**". It is also interpreted as "putting a second name in the poem other than one's original noun." Some sources misinterpret the meaning of the nickname: "A nickname is a symbolic name, a nickname." Some authors have described the nickname as follows: "A nickname is a well-known name in a person's social activity that is chosen by the person, used in conjunction with or in place of his or her first name. Anthroponym type"

The choice of nickname depends on the socio-political, cultural, spiritual views, artistic, ideological aspirations, beliefs and dreams of the nickname holder. In political figures, the nickname is often associated with the purpose of hiding his first name and surname, and his artistic and aesthetic aspirations in writers and artists. Understanding a nickname as a "fake name" is similar to a person's first name.

In classical poetry, the author uses his nickname in praise of the work. This method is called **compliment** among the poetic arts. **Compliment** means "**to ignite**" and is the movement of the speaker (from the first person to the second person) in lyrical and lyric-epic poetry. When the nicknames used in the Uzbek language are combined, it is obvious that our artist took the choice of nicknames very seriously. Alisher Navoi is one of the great people who paid special attention

to the choice of a nickname, the reasons for its use, the essence of which was described in a wonderful poetic lines. Nicknames in Navoi gazelles can come in the form of a reference or a syntactic function.

The nicknames used in the poems are mainly II and III person. Nicknames are used only in the last bytes of the poem. Literary nicknames have been used since ancient times as a name that reflects the style and ideas of each artist, as they are onomastic units used by Turkic writers, including Uzbek artists. Therefore, the nicknames from ancient times to the present day are formed on the basis of the laws of the language of the Uzbek people. During the period of the old Uzbek literary language, the forms of nicknames that historically belonged to the Arabic and Iranian lexical layers became more active. In the later stages of development of the Uzbek language, Arabic names of nicknames became widely used. The ways of formation of nicknames, the principles of naming, the motives of naming are common to many peoples, and in the choice of this nickname plays an important role such as the creative personality, the period in which he lived, the literary environment. An analysis of the linguistic literature shows that Uzbek language nicknames have not been the subject of a separate monographic study in Uzbek linguistics. There are some observations, but these onomastic units have not been studied on the basis of theoretical principles and methods for a particular system. When any word becomes a nickname, it undergoes various linguistic changes, the lexeme loses all stylistic-expressive color, acquires a secondary meaning. Nicknames are mainly used in the text of works of art, in commentaries. Therefore, they are interesting in terms of nominative and functional for Uzbek onomastics, that is, which artist they call, what functions they play in the artistic and scientific texts of the Uzbek language. Nicknames of the Uzbek language have appeared and are appearing at different stages of development of our language. They are unique onomastic units that objectively reflect information about the history of language, the history of literature, the history of the people and the spiritual heritage of our people. Nicknames are linguistic units that are formed on the basis of individual naming of artists, the need to distinguish it from others, to hide, to perform artistic and aesthetic tasks. Just as it is important to generalize and typify the names of beings (common noun), so it is necessary to name one of these things separately (proper noun).

Proper noun are grouped according to the different types of objects or events they refer to. Such groups can be large or small, depending on the number of proper noun types that make it up. Nicknames fully meet the linguistic and onomastic requirements (semantic, nominative, functional, structural) of proper nouns. Because they are onomastic units that have been used in the onomastic system of language for a long time. The collection and study of nicknames in the Uzbek language provides valuable information not only in the field of onomastics, but also in the field of Uzbek historical lexicology, dialectology, as well as ethnolinguistics, sociolinguistics, literary history.

## **CONCLUSION**

Therefore, when studying the works of Alisher Navoi in high school, we should not limit ourselves to language, literature, content or form. The deeper we study the gazelles, the more we will enjoy the treasures of Alisher Navoi's gazelles.

**REFERENCES:**

1. Avlakulov, Y. (2012). Linguistics of Uzbek language onomastic units: NDA. (p.13). Tashkent.
2. Begmatov, E. (1965). Anthroponymy of the Uzbek language. Tashkent.
3. Husanov, N. (1996). Lexical-semantic and methodological features of anthroponyms in the language of 15th century Uzbek written monuments. - Tashkent: Writer, Part 1.
4. Umarova, N.R. (2020). The concept of words in the works of Alisher Navoi. NamSU Scientific Information - Scientific Bulletin of NamSU, No. 11, pp. 257-262.
5. Umarova, N.R., & Abduvalieva, N. (2020). Conflicts in Alisher Navoi's Gazelles. International Journal of "Word Art". Special numbers 3. - Tashkent, pp. 248-255.

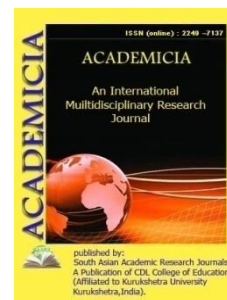
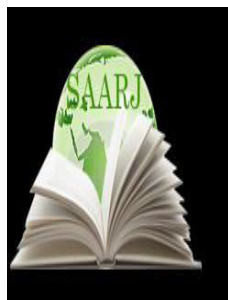

DOI: [10.5958/2249-7137.2021.01922.4](https://doi.org/10.5958/2249-7137.2021.01922.4)

## INNOVATIVE APPROACHES TO TEACHING HISTORICAL SCIENCE

**Yuldash Haydarov\***

\*Associate Professor,  
Head of the Department of "Methods of socio-economic sciences",  
Bukhara Regional Center for NRetraining and Advanced Training of Public Educators,  
Candidate of Historical Sciences, UZBEKISTAN  
Email id: haydarovyu@inbox.uz

### ABSTRACT

*The article focuses on innovative approaches in the process of organizing historical education on the basis of modern approaches. The history lessons provide vivid and analytical examples of innovative teaching. Examples of coverage of the contribution of the people of Uzbekistan to the great victory over the German - fascist invaders in the process of teaching the "History of Uzbekistan" are based on innovative approaches. In the process of radical reforms carried out in "New Uzbekistan", important points were also expressed about the importance of teaching historical education on the basis of innovations.*

**KEYWORDS:** Innovation, Science, Skill, Modern Lesson, Education, Training, Knowledge, Curriculum, Program, Style, Textbook, Technology, Competitive, Integration.

### INTRODUCTION

Significant reforms are being carried out in "New Uzbekistan" to equalize the education system in all spheres, as well as in the world standards, and today's globalization is preparing competitive personnel on a global scale. On the need to rely on innovations in the successful implementation of these processes, esteemed President Shavkat Mirziyoyev gave instructions to the consul in the buzzing of those who started to build a new Uzbekistan:

".....Who will win in the current period, when the times are rapidly developing? A new idea, a new idea, a state based on innovation will win. Innovation means a great future. When we start our great future from the today, we must start it exactly on the basis of innovative ideas, innovative approaches".

Teachers who teach history in general secondary schools will be able to meet the constructive requirements for reforming the education sector on an innovative basis, if they organize modern lessons on the basis of innovative ideas and innovative approaches. In the sources “pedagogical innovation is recorded as innovations and changes that are introduced into pedagogical activity, educational content and technologies in order to increase their effectiveness”.

The fact that the teacher of historical science also follows this definition and introduces innovations in his lessons increases the quality and effectiveness of education. To do this, it is necessary for teachers of historical science to enrich the subjects specified in the curriculum, programs and textbooks of general secondary schools with the necessary innovations at the level of modern requirements and to integrate them into the minds and hearts of students using innovative educational methods. For example, the contribution of the people of Uzbekistan to the great victory over the German-fascist invaders cannot be completely passed on the basis of the data of the 10-th class textbook published for students of secondary schools, which is now in practice.

**Methods:** A new period of study of this period of the history of Uzbekistan under the leadership and initiatives of the Distinguished President of our country Shavkat Mirziyoyev has begun. Archives with information on this topic were opened, and on the basis of the information provided by scientists from Uzbekistan and the world, completely new historical data were found and published.

As soon as the teacher of historical science has thoroughly studied these data and conducted a lesson using the method of “comparative analysis” in order to compare it with the old data, the students will understand the subject on the basis of modern requirements and their interest in knowing the innovations in the field of historical science will increase even more.

**Results:** The contribution of the people of Uzbekistan to the great victory in the fight against the German-fascist invaders was built in Tashkent on the initiative of the esteemed President Shavkat Mirziyoyev, an example of the content and essence of the monument “Matonat madhiyasi” (“Anthem of perseverance”), which is the only one in Central Asia now, is an explanation, as well as an arrangement of watching the film “Ilhaq” dedicated to the courage of Zulfiya aya Zakirova, organizing a round table or debates based on students' opinions about monument and film content will also help students to master innovations in the field of historical science.

Such collaborative activities of students (round table, debates and dialogue) motivate them to think independently, to seek creativity, to take initiative and to be creative. With this, educators-scientists for many years asked the question “Why do we train?, What do we train?, How do we train?, How can effective and resultant training be achieved?”. We will be composed of the answers to these questions. This process is evident in improving the quality and effectiveness of education through the use of innovative teaching methods in the organization of modern lessons.

The contribution of the people of Uzbekistan to the great victory of the German-fascist invaders in the Second World War, relying on the innovations that are the results of research in the field of the science of history of Uzbekistan, and the analytical explanation using the presented table data also provides a wide opportunity to find answers to the questions put forward by:

<b>№</b>	<b>Information available to date</b>	<b>New data revealed as a result of research</b>	<b>Comment</b>
1	It was said that about 1 million 500 thousand Uzbeks were engaged in the war.	In fact, about 1 million 951 thousand people were mobilized for war. It was found that 1 out of every 3 people participated in the war.	The names and destinies of 451 thousand compatriots were unknown
2	Information about how many of those who were exiled to other countries as “Ears” participated in the Second World War was not complete.	It was found out that more than 59 thousand of our compatriots, exiled to other countries as “Ears”, were mobilized in the army in the movement.	The fate of more than 59 thousand of our compatriots remained unknown.
3	It is said that 396 thousand citizens of Uzbekistan were killed in the war	In fact, more than 538 thousand citizens of Uzbekistan were killed in the war	The fate of more than 142 thousand citizens of Uzbekistan has been neglected
4	It is indicated that the number of Representatives of Uzbekistan awarded with combat orders and medals is 120 thousand people	In fact, more than 200 thousand of our soldiers and officers were awarded the state prize of combat	More than 80 thousand soldiers and offices were ignored.
5	280 people from Uzbekistan were awarded the title of Hero of the Soviet Union	In fact, 301 people of Uzbekistan were awarded the title of Hero of the Soviet Union	Information about 21 Uzbek Heroes of the Soviet Union has been ignored
6	It is indicated that more than 100 industrial enterprises have been transplanted from the Front regions to Uzbekistan	In fact, 151 industrial enterprises have been transplanted in front regions and products for front needs have been produced in Uzbekistan	Reconstruction and commissioning of 51 plants transplanted from the Front regions did not take into account the work of the people of Uzbekistan
7	During the War, 1 million people were transferred to Uzbekistan, of which 200 thousand were children.	In fact, 1 million 500 thousand people, including more than 250 thousand children were evacuated to Uzbekistan	About 500 thousand people and more than 50 thousand children who were transplanted were not given information. The Uzbek people shared with them one last piece of bread.

In the organization of modern lessons, teachers of historical science should inform the students about something else, so that there are some innovations, in order to introduce them into life,



certain material support will also be needed. Because we should say that the individual's capacity to spread such innovative ideas across the country could not be enough. In the teaching of the history of "Ancient Rome", the following example, which is not present in the current textbooks, attracts the attention of students. The purpose of this study is to enable students to understand the content of innovation in the example presented.

In ancient Rome, the name Oppian was a poet who wrote poems and epics on various topics. Emperor Aurelian awarded him for his epic "Fishing". The emperor's compliment intrigued the Romans, who read Oppian's epic "Fishing", and as a result, many of the inhabitants learned to fish and began to enjoy a new blessing on the table of the country's inhabitants. In this place, the teacher encourages the student to observe. Reader "Do the observation!" and supporting interactive techniques such as "Summarizing", encourages readers to find out what innovation is in this example. Pupils will realize that the Emperor was instrumental in spreading the new fishing ideas put forward in the poet's epic. In this way, the population has mastered fishing well and as a result, the administration of the country has been achieved. They will also understand the need for material incentive and support for the implementation of some innovations through the concrete example presented.

## **DISCUSSION**

Such examples presented in the lessons of modern history encourage students to persistently master science innovations, to introduce innovations in socio-economic and cultural spheres into life and to further contribute to the fate of the country. Unfortunately, the need for the use of innovations in modern textbooks in the curriculum, programs and textbooks on the subject of the proposed history for secondary schools in general has not been fully taken into account.

Therefore, the President of the Republic of Uzbekistan Shavkat Mirziyoyev, having thought about the educational plans and programs of educational institutions, criticized the fact that "The introduction of modern educational plans and methods is not at the required level".

It is necessary that the teacher of historical science, through the use of innovations in his lessons, give students modern knowledge and prepare the ground for them to become world-class competitive cadres. The teacher himself determines the methods of innovative activity of the teacher, based on the criteria of consulting, systematization, efficiency, result and application of the acquired knowledge in life. In order to achieve the intended purpose, the lesson will be able to use ICT, tables and schemes, dissemination materials, historical maps, contour maps, video graphics, multimedia, artistic literature, historical sources, thematic films, internet materials, advanced pedagogical technologies and interactive methods.

## **CONCLUSION**

An innovative approach to the teaching of historical science is an important activity of the teacher of historical science, which gives the students the opportunity to learn science innovations perfectly. They encourage independent thinking, critical analysis and logical conclusions and always strive for innovation. In fact, innovative education is the foundation of a great future, and the use of innovations in modern lessons is a guarantee of further development of historical education in Uzbekistan.

**LIST OF REFERENCES:**

1. Mirziyoyev Sh.M. Appeal to the Upper House. December 27, 2017 “People’s word,” December 23, 2017, page 1.2
2. Mirziyoyev Sh. M. We will resolutely continue our path of national development and take it to a new level. Volume 1 4. 283; 592. Page.
3. Mirziyoyev Sh.M. We will build our great future together with our brave and noble people. T., “Uzbekistan”, 2017.
4. Jorayev R, Yuldashev M and others. Improving the mechanism of continuous professional development of teachers. T., 2014. 2.51.52; 159. Page
5. Ishmuhamedov R, Yuldashev M. Innovative pedagogical technologies in education. T., 2013, 9; 277 page.
6. Davronov Z. Methodology of scientific creativity. T., 2007.
7. Jorayev N. Theoretical foundations of the philosophy of history. T., Spirituality, 2008.
8. Ilhomov Z. Methodology of historical science. T., 2013.
9. Madaraimov A, Fuzailova G. Historical sources T., 2005.
10. Modern education is an important basis for the development of society. Compilers: N.Rahmonkulova and others. T., 2017.
11. Karimov N. Duty before history. New Uzbekistan, October 22, 2020, No. 202.
12. Sobirov A. The source of the history of the homeland and the nation. New Uzbekistan, October 9, 2020.
13. Sagdullayev A. Education: History and the state of school textbooks. Enlightenment, August 5, 2020.

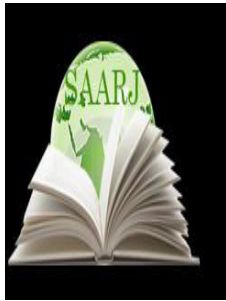

**ACADEMICIA**  
**An International  
 Multidisciplinary  
 Research Journal**  
 (Double Blind Refereed & Peer Reviewed Journal)

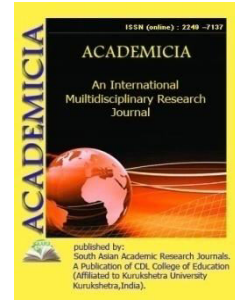

**DOI: 10.5958/2249-7137.2021.01923.6**

## ASSESSMENT OF THE METHODS OF THE STATE OF HYPERGLYCEMIA AT DIFFERENT BODY MASSES

**Nurilloeva Shakhodat Nurillo kizi\***

\*Bukhara State Medical Institute named after Abu Ali ibn Sino. Bukhara,  
 Republic of UZBEKISTAN

### ABSTRACT

*Abdominal obesity (and the closely related metabolic syndrome) is one of the most common diseases in the world. The urgency of the problem of the progression of abdominal obesity lies not only in its widespread prevalence, but also in the formation of a high risk of developing cardiovascular diseases and type 2 diabetes mellitus. The main reasons for the rapid development of obesity are considered high-calorie nutrition (which includes not only the quantity, but also the quality of food eaten), a sedentary lifestyle and a genetic predisposition. Until now, there has been a heated debate about methods for fast and high-quality weight loss.*

**KEYWORDS:** *Metabolic Syndrome, Obesity, Diet.*

### INTRODUCTION

Obesity is one of the most serious medical, social and economic problems of modern society. Over the past 40 years, there has been an increase in the number of people with overweight and obesity [1-3]. Singh G.K. et al., analyzing the data for 1976–2008, showed that in the adult ( $\geq 18$  years old) American population, the prevalence of overweight increased from 36.9 to 62%, obesity - from 8.7 to 27.4% [1]. A. Berghöfer et al. published a systematic review of the prevalence of obesity in Europe in 2008, summarizing data from the end of 1980 to 2005. In women in Portugal, Poland, Czech Republic, Romania and Albania. The population of Eastern Europe and the Mediterranean countries had higher rates of obesity than in the countries of Western and Northern Europe [4].

More than 1.9 billion adults are overweight, according to the World Health Organization (WHO). Of these, over 600 million people are obese. Over the past decade, the number of obese patients has increased by 75%. It is expected that by 2030 in Europe, 73% of men and 63% of women will suffer from obesity. With regard to the problem of overweight and obesity, screening programs among children and adolescents are being actively implemented to try to

solve this problem at the population level in many countries of the world (O'Connor EA., 2017, An Pediatr (Barc). 2019). [5].

It is known that overweight and obese people have a higher risk of developing metabolic syndrome, dyslipidemia, diabetes mellitus (DM), arterial hypertension, coronary heart disease, cerebral stroke, and cancer [6–9]. Findings from epidemiological studies have repeatedly confirmed a strong positive association between obesity and the risk of developing type 2 diabetes (T2DM). In the United States of America, an adult has a 9% increased risk of diabetes for every kilogram of weight gain [10]. Another study by Koh - Banerjee P. et al. in the United States, it has been shown that in men, an increase in body weight per kilogram leads to an increase in the risk of diabetes by 7.3% [11].

Currently, there are 3 groups of diagnostic criteria for MS: the WHO criteria, the criteria recommended by the Adult Treatment Panel III (ATPIII), and the criteria of the American Association of Clinical Endocrinologists. These MS criteria combine the presence of arterial hypertension (AH), hypertriglyceridemia, and a decrease in the level of high-density lipoprotein (HDL) cholesterol. According to the WHO criteria, for the diagnosis of MS, laboratory confirmation of insulin resistance is required, while according to the ATP III recommendations, obesity is mandatory (Dedov I.I. 2016).

The key link in the pathogenesis of MS is primary insulin resistance and compensatory hyperinsulinemia.

Insulin resistance - a decrease in the biological effects of endogenous or exogenous insulin - occurs in 58% of people with hypertension, 84% with hyper-triglyceridemia, 84% with type 2 diabetes. When type 2 diabetes is combined (or impaired glucose tolerance (IGT) with dyslipidemia, hyperuricemia and hypertension - the main components of MS, the detection rate of insulin resistance is 95%. This indicates that insulin resistance is indeed the leading mechanism of MS development (Schwartz V.A., 2015)

**Purpose of the study.** Evaluation of the methodology for the state of hyperglycemia at various body weights

### **Materials and research methods**

703 patients were examined in Bukhara, who underwent examination according to the program providing for the identification of the main components of MS. At the same time, the work used materials from a population study of 400 residents of Bukhara and 700 men of 20-69 years old in Tashkent.

During the survey, the following research methods were used: - a standard questionnaire developed for this study. Instrumental methods included: - ECG at rest in 12 conventional leads. Measurement of blood pressure by the Korotkov method. When assessing blood pressure (BP), the average values of 2 measurements taken with an interval of at least 2 minutes will be taken into account.

Overweight, according to the recommendations of the International Group on Obesity (1997), is fixed at the Quetelet index calculated by the formula:  $\text{weight (kg)} / \text{height (m)}^2, \geq 25$ , and IC levels  $\geq 30$  are taken as obesity. At the same time, in population studies for BMI it is recommended to take IC values  $> 29$  (Rose G. A., Blackburn H., 1968). The BMI criteria were

taken as  $CI \geq 30$ , since this CI level differs little from the BMI criteria recommended for population studies and, at the same time, meets the criteria for obesity recommended by the International Group on Obesity.

The state of glucose tolerance was assessed on the basis of the indicators of the standard glucose tolerance test (FGTT) with the determination of fasting glycemia, as well as 1 and 2 hours after taking the subjects 75 g. glucose. Assessment of glycemie parameters was carried out according to the Methodological Recommendations of the Russian Scientific Center of Endocrinology, taking into account the recommendations of WHO experts (1999). In accordance with these recommendations, the evaluation of the data obtained was carried out according to the following criteria (in mg%): normal glucose tolerance: at the level of fasting glycemia  $<100$ , 1 hour after glucose load  $<160$  and 2 hours after  $<100$ ; impaired glucose tolerance: fasting glycemia  $<100$ ; 1 hour after glucose load  $> 160$  and / or after 2 hours  $> 100$ ; diabetes mellitus: fasting glycemia  $> 100$ , 1 hour after glucose load  $> 180$ , 2 hours  $> 130$ .

### **Research results**

Obesity is a chronic multifactorial heterogeneous disease manifested by excessive formation of adipose tissue, progressing in the natural course, as a rule, having a high cardiometabolic risk, specific complications and associated concomitant diseases.

Currently, there are different classifications of obesity [20]. The proposed classification makes it possible to stratify patients according to the risk of complications of obesity, cardiometabolic risk using simple methods of anthropometric and clinical examination, to assess the metabolic phenotype of obesity and the effectiveness of the treatment, as a result of which the stage of the disease may change.

Many metabolic and hemodynamic disorders, as well as the pathology of many organs and systems, are often associated with obesity. Currently, there is no clear position, whether these conditions are its complication or they represent concomitant diseases, the onset and progression of which is aggravated by the presence of obesity. Complications and diseases associated with obesity include:

- impaired glucose tolerance (IGT), impaired fasting glycemia (IGN), or a combination of both (any of the three positions characterizes the state of prediabetes)
- type 2 diabetes mellitus
- Arterial hypertension
- hypertriglyceridemia / dyslipidemia
- Obstructive sleep apnea syndrome (OSAS)
- Non-alcoholic fatty liver disease (NAFLD)
- Polycystic ovary syndrome (PCOS)
- Osteoarthritis
- stress urinary incontinence
- gastro esophageal reflux disease (GERD)

- Limitation of mobility and social adaptation
- psycho emotional disorders and / or stigmatization

### Obesity and disorders of carbohydrate metabolism

Disorders of carbohydrate metabolism occur in at least half of obese patients. AO and obesity in general are important RFs for the development of not only CVD, but primarily type 2 diabetes. Parameters such as OT and BMI are important components of the scale for predicting the risk of developing diabetes. At the same time, the annual conversion of impaired glucose tolerance to diabetes mellitus is observed in 5-10% of patients and in 20-34% over 5 years, and with a combination of fasting glycemia ( $> 5$  mmol / L) and impaired glucose tolerance - in 38–65%. The likelihood of the transition of impaired glucose tolerance to diabetes mellitus is significantly higher in overweight individuals. The likelihood of developing type 2 diabetes mellitus is also determined by the duration of obesity and the characteristics of the deposition of adipose tissue in the body. Therefore, in obese patients, it is necessary to be examined for the detection of disorders of carbohydrate metabolism and type 2 diabetes (Table 2). Regular screening is carried out with a frequency of at least 1 time in 3 years - in case of a negative result, or more often - at the decision of the doctor (depending on the results of the previous examination and the number of risk factors).

**TABLE 1 DIAGNOSTIC CRITERIA FOR DISORDERS OF CARBOHYDRATE METABOLISM AND DIABETES MELLITUS (WHO 1999–2013)**

	Glucose concentration, mmol / l	
	Capillary whole blood	Venous plasma
<b>Rule</b>		
On an empty stomach and 2 hours after FGTT	$< 5,6$ $< 7,8$	$< 6,1$ $< 7,8$
<b>DIABETES</b>		
On an empty stomach or 2 hours after FGTT	$\geq 6,1$ $\geq 11,1$	$\geq 7,0$ $\geq 11,1$
Random definition	$\geq 11,1$	$\geq 11,1$
Random definition		
On an empty stomach (if determined) and 2 hours after FGTT	$< 6,1$ $\geq 7,8$ and $< 11,1$	$< 7,0$ $\geq 7,8$ and $< 11,1$
<b>IMPACTED GLYCEMIA STOMACH</b>		
On an empty stomach and 2 hours after FGTT	$\geq 5,6$ and $< 6,1$ $< 7,8$	$\geq 6,1$ and $< 7,0$ $< 7,8$

In addition to being over 45 years of age, additional risk factors for developing type 2 diabetes are: the presence of first-degree relatives with diabetes;

- Sedentary lifestyle;

- Women who have given birth to a child weighing more than 4 kg, or have had gestational diabetes;



- The presence of arterial hypertension;
- HDL level <0.9 mmol /l and / or TG level > 2.82 mmol / L;
- Polycystic ovary syndrome;
- History of NTG or NGN;
- Clinical manifestations associated with insulin resistance (for example, acantosisnigricans).

Analyzes the incidence of BMI and obesity among individuals with different categories of hyperglycemia. As it turned out (Table 3), in all categories of hyperglycemia, there is a higher incidence of BMI and obesity.

**TABLE 3 FREQUENCY OF OVERWEIGHT (BMI) AND OBESITY AMONG INDIVIDUALS WITH VARIOUS CATEGORIES OF HYPERGLYCEMIA**

Percentage frequency				
	Normal weight	BMI	Obesity	BMI + Obesity
No hyperglycemia	72,23	22,54	5,23	27,77
Hyperglycemia On an empty stomach	42,31	30,77 *	26,92 *	57,69 **
After 1 hour	42,77	32,70 *	24,53 **	57,23 ***
After 2 hour	17,91	26,87 *	55,22 ***	82,09 ***
Diabetes	19,51	26,83 *	53,66 **	80,49 ***

Note: The table shows the reliability of the differences in indicators relative to the group without hyperglycemia.

It was revealed that the frequency of BMI in patients with hyperglycemia 1 hour after glucose loading was higher than in those with impaired glycemia 2 hours after glucose loading and in patients with diabetes. Moreover, the frequency of BMI in patients with diabetes was slightly lower than in those with fasting hyperglycemia. This fact can be explained by the fact that obesity is more developed in patients with diabetes and its frequency is 2 times higher than in patients with fasting hyperglycemia and after 1 hour after glucose load. In general, overweight (BMI + obesity) is 2 times more common among people with fasting hyperglycemia and 1 hour after glucose load (57.69% and 57.23%, respectively) than with normal glycemic levels (27.77%). The highest incidence of overweight (BMI + obesity) occurs with hyperglycemia 2 hours after glucose load and with diabetes mellitus (82.09% and 80.49%). These data indicate that a violation of the sympathoadrenal phase of the glycemic curve is also important in relation to the incidence of overweight (BMI + obesity). Somewhat lower indicators of the frequency of overweight (BMI + obesity) in patients with diabetes in relation to the group of people with hyperglycemia 2 hours after exercise can be explained by the fact that patients with diabetes mellitus are registered and take certain measures to control weight.

Currently, when assessing body weight, it is customary to consider such an indicator as abdominal obesity (AO). According to the data obtained, AO is the least common in patients with normal glucose tolerance (32.74%). With fasting hyperglycemia, the frequency of AO is 1.8 times higher (42.31%), and with impaired glycemia 1 hour after glucose loading, it is 2.2 times

higher (50.94%) than with normal glycemic levels. the frequency of AO occurs in patients with diabetes (80.49%) and in the group of persons with impaired glycemia 2 hours after glucose load (74.63%). It should be noted that the differences in all indicators of the frequency of AO in the groups with different categories of hyperglycemia had statistically significant differences from the indicator of the frequency of AO in the group of persons with normal glucose tolerance.

## CONCLUSION

1. In the studied population, various categories of hyperglycemia are widespread. Along with such generally recognized categories of hyperglycemia as diabetes mellitus, diabetes, and hyperglycemia 2 hours after glucose load, hyperglycemia is also quite common 1 hour after glucose load.
2. The study of hyperglycemia 1 hour after glucose loading is important, because this category of hyperglycemia, on the one hand, is widespread in the population, and on the other hand, it can transform into hyperglycemia 2 hours after exercise and into diabetes mellitus.
3. For all categories of hyperglycemia, there is a higher incidence, BMI, obesity, including abdominal obesity. These components are more associated with post-load hyperglycemia, including impairment of the sympathoadrenal phase of the glycemic curve.

## BIBLIOGRAPHY

1. Singh GK, Siahpush M, Hiatt RA, Timsina LR. Dramatic Increases in Obesity and Overweight Prevalence and Body Mass Index Among Ethnic-Immigrant and Social Class Groups in the United States, 1976–2008. *Journal of Community Health*. 2010;36(1):94-110. doi: 10.1007/s10900-010-9287-9
2. Романцова Т. И. Эпидемия ожирения: очевидные и вероятные причины // Ожирение и метаболизм. – 2011. – №. 1. – С. 5-19. [Romantsova TI. Epidemiyaozhireniya: ochevidnyeiveroyatnyeprichiny. Obesity and metabolism. 2011;8(1):5-19 (In Russ).] doi: 10.14341/2071-8713-5186
3. Zaninotto P, Head J, Stamatakis E, Wardle H, Mindell J. Trends in obesity among adults in England from 1993 to 2004 by age and social class and projections of prevalence to 2012. *Journal of Epidemiology & Community Health*. 2008;63(2):140-6. doi: 10.1136/jech.2008.077305
4. Berghöfer A, Pischon T, Reinhold T, Apovian CM, Sharma AM, Willich SN. Obesity prevalence from a European perspective: a systematic review. *BMC Public Health*. 2008;8(1):200. doi: 10.1186/1471-2458-8-200
5. Wang Y, Beydoun MA, Liang L, Caballero B, Kumanyika SK. Will All Americans Become Overweight or Obese? Estimating the Progression and Cost of the US Obesity Epidemic. *Obesity*. 2008;16(10):2323-30. doi: 10.1038/oby.2008.351
6. Fernandez ML. The Metabolic Syndrome. *Nutrition Reviews*. 2007;65(6):30-4. doi: 10.1301/nr.2007.jun.S30-S34
7. Eisenmann JC, Katzmarzyk PT, Perusse L, Tremblay A, Després JP, Bouchard C. Aerobic fitness, body mass index, and CVD risk factors among adolescents: the Québec family study. *International Journal of Obesity*. 2005;29(9):1077-83. doi: 10.1038/sj.ijo.0802995

8. Flegal KM. Excess Deaths Associated With Underweight, Overweight, and Obesity. *Jama*. 2005;293(15):1861. doi: 10.1001/jama.293.15.1861
9. Kopelman PG. Obesity as a medical problem. *Nature*. 2000;404(6778):635-43.
10. Mokdad AH, Ford ES, Bowman BA, Nelson DE, Engelgau MM, Vinicor F, et al. Diabetes trends in the U.S.: 1990-1998. *Diabetes Care*. 2000;23(9):1278-83. doi: 10.2337/diacare.23.9.1278
11. Koh-Banerjee P, Wang Y, Hu FB, Spiegelman D, Willett WC, Rimm EB. Changes in Body Weight and Body Fat Distribution as Risk Factors for Clinical Diabetes in US Men. *American Journal of Epidemiology*. 2004;159(12):1150-9. doi: 10.1093/aje/kwh167
12. Peasey A, Bobak M, Kubinova R, Malyutina S, Pajak A, Tamosiunas A, et al. *BMC Public Health*. 2006;6(1):255. doi: 10.1186/1471-2458-6-255
13. Larsson SC, Wolk A. *Epidemiology of Obesity and Diabetes from: Contemporary Diabetes: Obesity and Diabetes*. Boston: HumanaPress, 2006; 15-36.
14. Кылбанова Е. С. и др. 10-летние тренды показателей массы тела у мужчин и женщин Новосибирска (1985-1995 гг.) // *Терапевтический архив*. – 2005. – Т. 77. – №. 3. – С. 64-67. [Kylbanova ES, Malyutina SK, Nasonova NV, Nikitin YuP. 10-letnie trendy pokazately massy tela u muzhchin i zhenshin Novosibirsk (1985-1995gg.) *Terapevticheskiy arkhiv*. 2005; 77(3): 64-67. (InRuss)]
15. Бондарева З.Г., Малютина С.К., Никитин К.П., Симонова Г.И., Федорова Е.Л. Ишемическая болезнь сердца в женской популяции г. Новосибирска: Результаты 7-летнего проспективного исследования // *Кардиология*. – 1998. – Т. 7. – С. 12-15. [Bondareva ZG, Malyutina S.K, Nikitin KP, Simonova GI, Fedorova EL. *Ishemicheskayabolezn' serdtsa v zhenskoypopulyatsii g. Novosibirsk: Rezul'taty 7-letnego prospektivnogoissledovaniya. Kardiologiya*. 1998; (7):12-15. (InRuss)]
16. Кылбанова Е. С. и др. Распространенность избыточной массы тела и ожирения среди пришлого городского населения Якутии // *Вестник Новосибирского государственного университета. Серия: Биология, клиническая медицина*. – 2006. – Т. 4. – №. 1. – С. 5-13. [KylbanovaES, MalyutinaSK, ShcherbakovaLV, SimonovaGI. *Rasprostranennost' izbytochnoy massy telaiozhirenyasrediprishlogogorodskogonaseleniyaYakutii. Vestnik NGU* 2006; 4(1); 5-12. (In Russ)].
17. Sidorenkov O, Nilssen O, Brenn T, Martiushov S, Arkhipovsky VL, Grijbovski AM. Prevalence of the metabolic syndrome and its components in Northwest Russia: the Arkhangelsk study. *BMC Public Health*. 2010;10(1):23. doi: 10.1186/1471-2458-10-23
18. NurilloevaSh.N., JuraevaKh.I. Adequacy pharmacotherapy of metabolic syndrome// *World journal of pharmaceutical research*. August-Sept. - 2020. Volume 9. Issue 12.–P. 48-53.
19. Mokdad AH, Ford ES, Bowman BA, Dietz WH, Vinicor F, Bales VS, et al. Prevalence of Obesity, Diabetes, and Obesity-Related Health Risk Factors, 2001. *Jama*. 2003;289(1). doi: 10.1001/jama.289.1.76
20. Safarova G.A. Vasorenal hemodynamic changes in patients with chronic kidney disease in comorbidity with hypertonic disease. *Asian journal of Pharmaceutical and biological*

---

research 2231-2218 <http://www.ajpbr.org/> Volume 10 Issue 2 MAY-AUG 2021  
10.5281/zenodo.5464135 Page 66-71.

21. ZhuraevaKh.I., Ochilova D.A., KudratovaD.Sh. Prevalence and detection of diabetes mellitus among the female population //Electronic scientific journal "Biology and Integrative Medicine". - 2016. - No. 2. - P. 80 - 87.
22. ZhuraevaKh.I. KayumovL.Kh.,Ubaidova D.S., DzhabborovZh.Zh. The relationship of myocardial infarction with metabolic syndrome //Electronic scientific journal "Biology and Integrative Medicine". - 2019. - No. 8. - P. 66 - 77.
23. Hu G, Lindström J, Valle TT, Eriksson JG, Jousilahti P, Silventoinen K, et al. Physical Activity, Body Mass Index, and Risk of Type 2 Diabetes in Patients With Normal or Impaired Glucose Regulation. Archives of Internal Medicine. 2004;164(8):892. doi: 10.1001/archinte.164.8.892

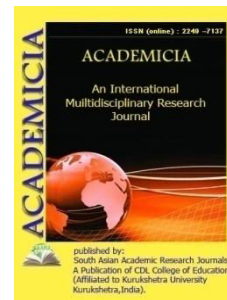
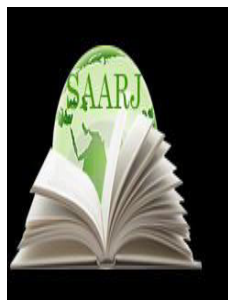

DOI: **10.5958/2249-7137.2021.01924.8**

## IGNITED ROCKS - ENERGY-SAVING RAW MATERIALS FOR PRODUCTION OF PORTLANDCEMENT CLINKER

**Mironyuk Nina Anatolejevna\***; **Maxsudova Nozimaxon Djaparxanovna\*\***;  
**Atabayev Farrux Baxtiyorovich\*\*\***; **Abdullayeva Nigoram Maxmudovna\*\*\*\***

<sup>1,4</sup>Academy of Sciences,  
Institute of General and Organic Chemistry,  
STROM Research Laboratory and Testing Center,  
Tashkent UZBEKISTAN

### ABSTRACT

*The article discusses the possibility of using and the need to introduce local igneous rocks in order to reduce heat consumption in the production of Portland cement clinker. A list of large surface deposits of igneous rocks with explored and undiluted reserves of raw materials on the territory of Uzbekistan is presented. Their chemical and mineralogical composition and melting temperature range have been determined. The compositions of raw mixtures and the activity of clinkers when using igneous rocks as an aluminosilicate additive and flux as a mineralizer are indicated. The benefits and prospects of using igneous rocks in clinker production are summarized.*

**KEYWORDS:** *Igneous Rocks, Aluminosilicate Raw Materials, Floating Mineralizers, Melting Temperature Range, Raw Mix, Clinker*

### INTRODUCTION

The cement industry in terms of the consumption of fuel and energy resources is second only to the metallurgical industry, and a regular increase in prices for them year after year leads to an increase in the cost of products. It is known that one of the promising directions for reducing heat consumption in the production of clinker is the use of components with a high content of low-melting components, the presence of which in the composition of the raw mixture contributes to an increase in its reactivity, a decrease in the firing temperature and thereby - to reduce the cost of clinker and the final product as a whole.

The world practice of the production of Portland cement clinker indicates that to ensure the proper reactivity of the raw mixture, it is more preferable to use such raw materials as a conditionally clay component in which silica is presented either in an amorphous (X-ray amorphous) state, or bound in aluminosilicates and silicates [1-6]. These materials include numerous igneous rocks that make up the upper shell of the earth's crust. Igneous rocks occupy 95% of the volume of the Earth's outer shell, which is 25% of the continental area, are products of solidification of natural silicate melts - lavas and magmas and have a constant chemical composition, therefore they are of significant interest as a raw material for the silicate and, in particular, for the cement industry. In accordance with the chemical composition and properties, igneous rocks are divided into acidic ones with a content  $\text{SiO}_2$  over 65%, consisting of quartz, feldspars (such as granites) and basic, containing (40-52)%  $\text{SiO}_2$  and consisting mainly of plagioclases and pyroxenes (such as basalts). Due to the fact that magma erupted to the Earth's surface in the form of lava flows quickly solidifies, the formed rock usually has a fine-crystalline structure and contains a significant amount of a vitreous phase, which facilitates its melting. Therefore, igneous rocks are of great interest as a raw material for the production of Portland cement clinker. The high content of iron oxide in the chemical composition of igneous rocks makes it possible to use this iron-containing component as a mono-additive and as a flux-mineralizer of raw mixtures in compositions together with limestone and clay components.

To solve the urgent problem of reducing heat consumption for the production of clinker, it was necessary to search for analogues of the above components within the raw material base of Uzbekistan. According to the Committee of Geology of the Republic of Uzbekistan, on the territory of the republic there are large surface deposits of igneous rocks with explored and undiluted reserves of raw materials, such as: Hawasai basalts - on the southeastern slopes of the Kuramin ridge; Beshkizylsay - in the area of the village. Nevich, Chatkal ridge; Asmansay basalts - in the north of the Nurata ridge; diabase-pyroxenites of the "Karatash", "Belyaushsay-I" and "Belyaushsay-II" deposits, the Tillatag deposit of the Navoi region; Vakhshivardiabase-porphyrates - on the western spurs of the Gissar ridge; metabasalts of Uchkuduk, Northern Tamdytau; mrachibasalts Chazak and Gaga; diabase-porphyrates of the Pistaltau and Arvaten deposits in the Jizzakh region; diabase-porphyrates and andesite-porphyrates of the Kainar-Shavazsai deposits in the Tashkent region; diabase-pyroxenites of the Kizil-Olminsky deposit in the Surkhandarya region; diabase-porphyrates and basalts of the Markhamat deposit in the Andijan region, etc.

Studies of the chemical and mineralogical composition of rocks of the indicated deposits show that the content  $\text{SiO}_2$  they belong to the group of basic igneous rocks with a fine-crystalline structure, which ensures their low melting point (1080-1200)<sup>0</sup>C and the possibility of obtaining a mobile silicate melt when used in the composition of a clinker raw mixture as an aluminosilicate component. The presence in the composition of igneous rocks of Uzbekistan (from 4 to 14)%  $\text{Fe}_2\text{O}_3$  predetermines their purpose as iron-containing corrective additives to clinker raw mix.

Iskandarova M.I., Pulatov Z.P., Butaev E.M. et al., diabase-porphyrates of the Pistalitausky, Arvatensky and basalts of the Asmansai deposits of the Jizzakh region, diabase-pyroxenites of the Belyaushsai-I, Belyaushsai-P of the Tillyatag deposit in the Navoi region, diabase-porphyrates and andesite-porphyrates of the Kaynazar region -Olminsky deposit of Surkhandarya region, diabase-porphyrates of Markhamatsky deposit of Andijan region, etc. as alternative sources of unconventional raw materials that can replace traditionally used iron-containing and



aluminosilicate components as an unconventional mineralizer and conditional aluminosilicate component of Portland cement raw mixture [7-10].

Based on the results of experimental studies, the authors have issued practical recommendations on the advisability of partial or complete replacement of the clay component and the complete replacement of the iron-containing corrective additive with igneous rocks, which accelerate the processes of clinker formation due to the formation of silicate melt at the low-temperature stage and the formation of clinker at relatively low firing temperatures. (1300-1350<sup>0</sup>C).

The limit of the chemical composition of the studied igneous volcanic rocks is determined, %: pp.=2,10-5,70; SiO<sub>2</sub>=40,50-50,40; Al<sub>2</sub>O<sub>3</sub> = 11,50-16,50; Fe<sub>2</sub>O<sub>3</sub> = 6,60-13,90; CaO = 4,50-15,50; MgO = 2,80-8,2; Na<sub>2</sub>O = 1,5-3,5; K<sub>2</sub>O = 1,2-4,5.

Later, these studies were continued by Orazymbetova G.Zh. replacement of the traditionally used ferruginous mineralizers in the composition of raw mixtures for burning clinker with basalts of the Berkuttau area of the Republic of Karakalpakstan [11-12].

It was found that the melting temperatures of igneous rocks are within (beginning-end 1100-1250)<sup>0</sup>C. The acceleration of the process of mineral formation during the firing of raw mixtures containing igneous rocks is explained by the peculiarities of the chemical and mineralogical composition of unconventional raw materials. The reaction of mineral formation during the roasting of standard raw mixtures using an iron-containing component as a mineralizer (cinder, hematite rocks, AGMK slags, etc.) occurs up to a temperature 1300<sup>0</sup>C. The reaction of interaction of free oxides with the formation of clinker silicate minerals mainly occurs in the solid phase. As the temperature rises to 1450<sup>0</sup>C the process takes place in the presence of a partial melt of aluminoferrite and aluminate phases. In raw mixes when using an unconventional mineralizer (igneous rocks), in which a glass phase is present, which melts at a relatively low temperature. At the same time, in contrast to standard raw mixtures, the reaction of mineral formation takes place in a silicate melt, which mainly contains SiO<sub>2</sub>, Al<sub>2</sub>O<sub>3</sub>, Fe<sub>2</sub>O<sub>3</sub> and CaO. The introduction of igneous rocks into the composition of raw mixtures in an amount of (8-23)% contributes to the formation of a silicate melt of low viscosity and high fluidity already at a temperature (1150-1200)<sup>0</sup>C, which leads to a sharp acceleration of the process of the reaction of mineral formation. Firing of raw mixtures containing igneous rocks proceeds intensively and clinker formation practically ends at a temperature (1350-1400)<sup>0</sup>C with the formation of silicates, aluminates and calcium aluminoferrites, as evidenced by the insignificant content CaO<sub>free</sub> (less 1 % the masses) in cakes fired in a laboratory silite furnace with an exposure time of 10 min. At the same time, the crystallization of clinker minerals is characterized by uniformity and fineness.

In the proposed compositions of raw mixtures, the content of igneous rock (10-25)% is within the limits. When the content of igneous rock is more than 23%, the clay (aluminosilicate) component is completely absent. Under the conditions of firing a two-component raw mixture, with the complete exclusion of quartz-containing clay components, the reaction of formation of silicate, aluminate and aluminoferritic minerals occurs at a high rate at a relatively low temperature.

When using igneous rocks, it becomes possible to exclude from the composition of raw mixtures not only scarce and expensive iron-containing additives, but also clay shales, clays, loess-like loams, the extraction of which is associated with the withdrawal from land use of fertile lands suitable for agriculture and the deterioration of the ecological situation in the regions. The use of

a two-component raw mixture with the exclusion of clay components greatly simplifies the technological process of preparing the raw mixture, reduces the moisture content of the sludge in the wet method of production, in the dry method, due to the high flowability of the raw mixture, no clogging of the heat exchanger leaks occurs, a stable coating is formed on the surface of the refractory lining of furnaces, etc. .d. The use of igneous rocks as an aluminosilicate component and a mineralizer of the raw mixture helps to reduce the temperature of clinker formation, increase the productivity of furnaces and reduce heat consumption without deteriorating the quality of clinker and cement.

For the purpose of large-scale introduction of igneous rocks into clinker production, the Republican standard O'zDSt 2950-2015 "Raw materials for the production of Portland cement clinker. Technical conditions ", which regulates the chemical composition of igneous rocks suitable for use in clinker production:  $\text{SiO}_2$  - not less 40%;  $\text{Al}_2\text{O}_3$ - not less 8%;  $\text{MgO}$ - not less 7%;  $\text{SO}_3$ - not less 2,5%;  $\text{TiO}_2$ - not less 2%;  $\text{P}_2\text{O}_5$ - not less 0,6%;  $\text{R}_2\text{O}=\text{Na}_2\text{O}+0,658 \text{K}_2\text{O}$ - not less 6%.

Pilot tests carried out at JSC Kizilkumcement and JSC Kuvasaycement have convincingly proven the feasibility of using local unconventional raw materials - igneous rocks as a mineralizer and a conventional aluminosilicate component in the production of Portland cement clinker. With the development of the new technology, the hourly productivity of all rotary kilns at Kuvasaycement JSC increased to 20% (from 25.0 t / h to 30.0 t / h), the specific gas consumption per ton of clinker decreased by 11%, the activity of clinker increased from 43.0 MPa to 50.5 MPa, and at Kizilkumcement JSC the increase in the hourly productivity of the furnaces averaged 18.0% (from 114 t / h to 135 t / h), the decrease in the specific gas consumption per ton of clinker - (6 -8)%, an increase in clinker activity - from 40.5 MPa to 50.3 MPa.

The economic indicators achieved at the same time (availability and cheapness of unconventional raw materials, low firing temperature, an increase in the rate of mineral formation processes, a decrease in the cost of clinker, savings in fuel and energy resources consumption, etc.) dictate the need for a large-scale introduction of technology for the use of igneous rocks at all cement plants in the republic.

## REFERENCES

1. Rubin V.L., AkhmedzhanovKh.I. It is time to actively tackle energy problems. Cement and its application. 2005. No. 5. - 35 p.
2. Pashchenko K.A. The theory of cement. - Kiev. : Budivel'nik. 1991 .-- 108 p.
3. Sanjasuren R., ErdenabatTs., Rumyantsev P.F. et al. Synthesis of Portland cement clinker using basaltoid rock // J. - Ulan-Ude. 2010.-p. 1-4.
4. Zhanikulov N.N. Creation of energy- and resource-saving technologies of Portland cements and wall ceramics using coal mining waste and technogenic raw materials // Dissertation for the degree of Doctor of Philosophy (PhD). - Republic of Kazakhstan, Shymkent, 2020.144 p.
5. Taimasov, B.T. Complex use of natural and technogenic raw materials in the production of low-energy-consuming cements: monograph / B.T. Taimasov, T.M. Khudyakova, N.N. Zhanikulov. - Shymkent: SKSU them. M. Auezova, 2017 .-- 205 p.

6. Gribenyuk VM, Koshevoy Yu.N. The use of rocks in the production of building materials. Tutorial. - Ekaterinburg. Publishing house Ural. un-that. 2017 .-- 100 p.
7. Makhmudova V.Sh., Iskandarova M.I. Low-temperature fired cements from basalt rocks of Uzbekistan // Tez. report Int. conf. on chemical technology HT 07 dedicated to the 100th anniversary of the birth of Acad. N.M. Zhavoronkova. -M., 2007.T.1. - S. 209-212.
8. Iskandarova M.I., Makhmudova V.Sh. Low-temperature fired cements from basalt rocks of Uzbekistan // Int. conf. "Chemical technology", dedicated. to the 100th anniversary of Academician Zhavoronky. - Moscow. 2007. Volume 1. - S. 209-212.
9. Makhmudova V.Sh. Development of technology for obtaining low-temperature cements using basalt rocks of Uzbekistan // Avt. diss. Cand. tech. sciences. -Tashkent. 2008 .-- 16 p.
10. Pulatov ZP, Butaev E.M. Industrial development of cement production technology using an unconventional component - igneous volcanic rocks. // Cement and its application. 2011. No. 3. - S. 134-136.
11. Orazimbetova G.Zh., Iskandarova M.I. Synthesis and research of clinkers with a high silica modulus based on raw materials from new deposits of Karakalpakstan. // Uzbek Chemical Journal, 2018, -№1, -C.3-9.
12. Orazimbetova G.J., Iskandarova M.I., Mironyuk N.A., Kurbanova A.Dj. Investigation of reactivity and synthesis of clinkers from raw materials with the use of basalt rocks. // European Science Review. - Austria, Vienna, September-October, 2018. - No. 9-10. - P. 51-55.



**ACADEMICIA**  
**An International**  
**Multidisciplinary**  
**Research Journal**  
 (Double Blind Refereed & Peer Reviewed Journal)

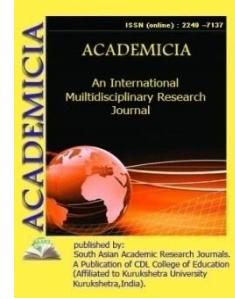

**DOI: 10.5958/2249-7137.2021.01925.X**

## TEACHING TO WORK ON THE TEXT IN THE MASTERING OF THE CONTENT OF THE STORY “THE YOUTH OF ALISHER” (GRADE 4)

**Kurbonov Zayniddin\* ; Kilichboyeva Khurshida\*\***

\* Doctor of philosophy in philological Sciences,  
 Samarkand State University,  
 Samarkand, UZBEKISTAN  
 Email id: Kurbanovzaynidin1@gmail.com

\*\*Teacher,  
 Samarkand City-74 school, Samarkand,  
 UZBEKISTAN  
 Email id: mohinurshakarova@gmail.com

### ABSTRACT

*The article reviews the analysis of the story “the youth of Alisher” in the primary class “reading book” to teach the pupil. As we know, life in the story is reflected by images. At its center stands a person, his attitude to nature and society. The main thing is that in the process of analyzing the story, independent thinking appears in the readers. Teaching students to work on the text of the story implies teaching and learning through the formation and cultivation of the skills of literary and aesthetic analysis in them and it is also aimed at enhancing the students' independent thinking skills, strengthening their memory, improving their reading skills and reacting to events expressed in the story, enriching the readers' dictionary with new words.*

**KEYWORDS:** *Story, Knowledge, Skills, Qualifications, Reading, Competent, Selective Reading, Interactive Method, On The Foot, Vigilant, A Sniper, A Beard, A Deer.*

### INTRODUCTION

Analysis of its content in the reading of the story and on this basis, the development of students' speech, independent thinking skills, strengthening their memory, improving reading skills, react to the events expressed in the story, analyze the content of the story, as well as compare the facts, comments, conclusions, the central role is played by the identification of links between events, behavior, generalization, enriching the reader's dictionary with new words. We know that speech is associated with contemplation, so it is grown in a state of inextricably connected with

contemplation. In order for the story read in the process of the lesson to be understood by the readers consciously, to understand the meaning and idea, logical types of work are used, such as dividing the text into a holistic, whole, into parts, comparing, drawing an analogy, generalizing. In the analysis of the text of the story, different ways of work, that is, students tell the main participants in the story, under the guidance of the teacher draw up a plan of the work. The participants may not be told in sequence by the pupils, but the teacher asks them to say in the order of participation in the game. As a result, a drawing of the story is drawn up under the guidance of the teacher. For example, in the 4th grade on the basis of the text on mastering the content of the story “the youth of Alisher”, the following works are carried out:

- Answering the teacher's questions on the content of the text.
- Perform question-and-answer assignments based on the text of the story.
- Compilation of questions from readers on the content of the story.
- Draw pictures corresponding to the content of the story.
- Dividing the text of the story into parts.
- Finding the title of each track.
- Making a plan for the story.

Answering the teacher's questions on the content of the text.

In the reading lessons of the primary classes, the growth rates of the students’ speech are a properly organized re-storytelling. In the school experience, there are full, concise, selective, and creative re-storytelling types. For elementary schoolchildren, it is much easier to re-narrate the text in full or close to the text, while other types are relatively difficult. On the content of the story, which was read in the re-storytelling, the teacher's question should focus on the details of the story, on the reason-consequences of the connection between certain events. A person participating in the development of the plot of the work, their behavior plays a key role. Students are well aware of the contents of the work with the help of an analysis of the persons participating in it and their behavior, characteristic features. The question of the teacher should be directed to tell about what the heroes of the work did, where and under what circumstances their behavior occurred, to give a consistent statement of events and to enlighten their interdependence. For example:

— Count the main contestants in the story.

G‘iyosiddin Kichkina, bek, mother, Alisher, two neighboring children.

— Bek for some reason — the boy is not a bad, vigilant, let him protect from the alien eye — said.

G‘iyosiddin Kichkina was having a conversation with a bek in a garden. Alisher rejoiced and ran to his father, kissed him with a hug around his neck, ran to his mother, standing aside, went out into the street together.

What did Alisher talk about with his comrades?

— My uncle, let the pastime, which brought from the steppe. He is a master sniper. He speaks with interest about the behavior, behavior of animals.

What did Alisher answer when his partner said that I would become a hunter when I was older?

- Our homeland is Herat which is like paradise. It is desirable to hunt wild animals like wolves, tigers. In a world where there is no harmless creature as a deer.

A consistent re-narrative of the contents of the read work will help to formulate its plan. When making a plan, the reader will have the story in the components and determine in which parts the main idea. All this is considered an analytical work. Then the synthetic is switched to work, that is, the children find a title for the parts of the story. In the process of making a plan under the guidance of the teacher, the students in each part of the story read, the main and secondary issues are thinking about what is the phrase from, how to express the idea briefly and clearly. It is necessary to work on the topic of finding a title, to collective discussion of the title in which the students are composed, the process of drawing up a plan itself, the ability of the child to think, to prove his reasoning in it, to educate reasoning habits. Perform question-and-answer assignments based on the text of the story. This type of exercise allows students to develop the ability to hold discussions on what has been read, evaluate the heroes participating in the work and determine the link between the life stories described by the author and the idea of the work. Questions posed in this type of work should motivate the readers to think independently. For example, the use of the following questions and assignments on the story “the youth of Alisher” is of great importance.

- What does Alisher mean when he says “the school teaches many secrets of life”?
- What qualities in the heroes of the story do you like? (Or do not like?)
- How do you explain the sentence of his father “a scientist cannot be offended”?

Compilation of questions from readers on the content of the story. Teaching readers to compose a question gives a good result when working on the text. The teacher draws the attention of the students on the way to formulate a question in the text and before compiling a question, carefully read the text, show the participles and understand that the question should be divided into parts. At the initial stage of training to formulate a question, this exercise is performed as a team. For example, on the story “the youth of Alisher”, the task is given to compose the following question:

- Read the first and second paragraph in the story and draw up a question on these parts.

What did G‘iyosiddin Kichkina say about his son?

- Compose questions and assignments on the interpretation of the meaning of the words used in the first paragraph in the story. (comment on the meaning of the words on the foot and vigilant)

Where did the G‘iyosiddin Kichkina stand on his feet and talk with a bek?

- The son is not a jackdaw, let the vigilant stand out from the alien eye! - Who said?
- Compose questions on the heroes of the story.

The older the children were surprised at what Alisher said?

Work on the dictionary:

oyoq ustida (*on foot*) – standing upright;

tiyrak – vigilant, cautious;



tangri (*God*) – Allah, in the sense of God;  
takya - headdress, cap, hoof.

Draw pictures corresponding to the content of the story. In some texts, ready-made pictures corresponding to the part of the text are not given; they describe it in words by the children themselves. The story is read and analyzed by parts, then the pupils read the text, the teacher asks them how to draw a picture. Work on the remaining parts is also processed in this way. For example, on the surface of the text of the story “the youth of Alisher”, it is possible to draw the following pictures as an assignment:

1. Draw a picture that reflects the conversation in the garden.
2. Draw a picture of the status of played dumb with Alisher and friends.
3. Draw a picture of the condition reflected by Alisher, deer and friends.

Divide the story text into parts and find the title. In the process of analyzing the parts of the text, the students, under the guidance of the teacher, determine the main idea in each part and find a heading for it; the teacher writes the headings in the style of the plan into a hat. The readers are assigned to divide the text into parts, using the given headings. They read the text and divide the part that belongs to the headlines. For example, on the surface of the text of the story “the youth of Alisher”, the following title and small texts are formed:

#### *BOG‘DA*

G‘iyosiddin Kichkina bog‘da bir bek bilan oyoq ustida turib suhbat qurar edi. Alisher sevinib, otasi oldiga yugurdi, bo‘ynidan quchub o‘pdi-da, chetda turgan onasi oldiga yugurdi, birga cho‘chaga chiqib ketdilar.

— O‘g‘il chakki emas, tiyrak, begona ko‘zdan asrasin! — dedi zimdan bolani ta‘qib qilib turgan bek.

G‘iyosiddin Kichkina kamtarona ohangda:

— Illohim, mulla bo‘lsin, zehni yaxshi, — dedi.

So‘ng o‘zi ham ichida: “Ha, Tangrim yomon ko‘zdan asrasin”. — deb qo‘ydi.

In English:

#### *IN THE GARDEN*

G‘iyosiddin Kichkina was having a conversation with a bek in a garden. Alisher rejoiced and ran to his father, kissed him with a hug around his neck, ran to his mother, standing aside, went out into the street together.

— The boy is not a bad, vigilant, let him protect from the alien eye! - said bek who was looking and following the child.

G‘iyosiddin Kichkina with the modest tone:

— My God, be a mullah, his mind is good, he said.

Then he himself said inside: “Yes, God protect him from the evil eye please!” - put that.

#### *KIYIK*

Daraxtlar orasidan otilib chiqqan kiyik Alisherni hidlab, erkalanib surkaldi.

- Seni tanir ekan, qurmagur, xo‘p o‘rgatibsan o‘zinga, —dedi bolalardan biri.
- Rostmi, qoyilman! —deya ma‘qulladi zavq bilan ikkinchi bola.
- Tog‘am, ermak bo‘lsin deb, dashtdan oliob kelgan edi. U kishi usta merganlar. Hayvonlarning, ayniqsa, kiyiklarning xulq-atvori, qiliqlari haqida maroq bilan hikoya boshlasalar, kullib jahonni unutib yuboray deyman.

In English:

#### *DEER*

The deer, which was thrown out of the trees, smelled the Alisher and drove away.

- You taught yourself to this deer abscess while deer knows you, - said one of the children.
- Is it true! I am really impressed! - The second child with pleasure pleased.
- My uncle, let the pastime, which brought from the steppe. He is a master sniper. I'll laugh and forget the world when he speaks with interest about the behavior of animals.
- *OVCHI*
- Pok, ozoda, ajoyib, suluv jonivor, — dedi zavq bilan tomosha qilgan bola.
- Katta bo‘lganimda ovchi bo‘lgumdir, tog‘larda merganlik qilishning kayfi zo‘r, — dedi kiyik ketgan tomonga tikilganicha ikkinchi bola.
- Bizning vatanimiz Hirot o‘lkasi jannatmakon desak lof bo‘mas, do‘stim, — dedi Alisher cho‘p bilan yerga nelardir chizgan holda, boshini ko‘tarmasdan. — Meningcha, bo‘ri, yo‘lbars yanglig‘ vahshiy hayvonlarni ov qilmoq ma‘qul. Kiyikday beozor maxluq, fahmimcha, dunyoda kamdur deyman.

In English:

#### *HUNTER*

- Clean, neat, wonderful, juicy creature, - said the boy who watched with pleasure.
- When I'm older I'll be a hunter, the pleasure of being a sniper in the mountains is cruel, - said the second child until the deer is sewed to the side gone.
- Our homeland is the Land of Herat is like paradise, my friend – said Alisher without raising his head, drawing what is on the earth with a broom. — In my opinion, it is better to hunt wild animals like wolves, tigers. A gullible creature is a deer, I would say, deer is rare in the world, in my opinion.

#### *MAKTAB*

- Ov qilmoq, merganlik — ermak narsa, lekin eng zo‘r zaruriyat maktabdir. Turmushning ko‘p sirlarini maktab o‘rgatadi.
- Suhbatning bunday keskin o‘zgariganidan shoshib, bir on jim qolgan bolalarning kattarog‘i:
- Kim o‘rgatdi senga bu gaplarni — deb so‘radi Alisherga tik qarab.

— Bilaman-da, otam hamisha: “Olim odam xor bo‘lmaydi”, — deydilar. Otamning oldiga olim odamlar ko‘p keladi, turli gap-so‘z, ajoyib g‘azallarni chetda o‘ltirib tinglaymen, o‘zim ham xiylagina g‘azallarni yod bilurmen...

Alisher yaqinda maktabga borajagini, otasi ko‘pdan va‘da qilib yurganini aytmoqchi edi, lekin aytmadi.

In English:

### *SCHOOL*

— Hunting, marksmanship is a pastime thing, but the most salty necessity is school. Many secrets of life the school teaches.

From such a sharp change of conversation, the older the children who are in hurry and a moment silent:

— Who taught you that? – he asked, looking straight at Alisher.

— I know my father always said, “A scientist is not despised”. Many scholars come to my father, I sit outside and listen to all kinds of gossip and wonderful poems, and I also memorize a few poems.....

Alisher wanted to say that he would go to school soon, as his father had promised, but he did not say.

Make a plan for the story. The plan will help the reader in conscious and deep understanding of the content of the text, in distinguishing the main idea, in determining the consistency of events, in understanding the interconnection of parts of the text. Working on the plan, students develop their speech and thinking. They learn how to divide the text into completed parts of the content and find the basis of each part, find a short and clear title to them and form it as part of the plan. Thus, once the skills of drawing up a plan are formed in students, in 3-4-th classes, they independently divide the text into parts, make a plan for each part. The plan is formulated in the form of a comb and an atov sentence, in which each part must be in the form of some kind of sentence.

At the final stage of the analysis.

— What did Alisher talk about with his comrades?

— What qualities of Alisher did you like?

— What qualities of comrades liked you? (Or did not like?)

— Why does he disapprove of his comrades' views on hunting?

— What does Alisher mean when he says “the school teaches many secrets of life”?

— Have you ever had events in your life similar to those in the story?

With the help of questions and assignments such as, it is possible to find out how the readers understood the conclusion of the fairy tale.

In conclusion, the compactness of the story, first of all, the simplicity of the language, short, sharp and folk language strongly affects the child's emotions, and is an important material in the

cultivation of the speech of pupils. The actions, behaviors, and speech characteristics of the protagonists of the story capture the reader's attention. Thus, in the primary classes, the use of methods and methods, types of analysis, which strongly affect the personality of the reader in the analysis of the text of the story, in general, ensure the assimilation of knowledge, corresponding to their level, serves to increase the knowledge, skills, qualifications, of the students.

**LIST OF REFERENCES:**

1. Kosimova K., Matchonov S., Gulomova X., Yoldasheva Sh., Sariev Sh. About us Methods of teaching mother tongue (textbook for students of the Faculty of Primary Education): - T.: "Publisher", - 2009. 352
2. Zunnunov A. et al. Methods of teaching literature. - T.: "Teacher", 1992. 160 pages.
3. Tolipov O., Usmonbekova M. Application bases of pedagogical technologies. - T.: "Science", 2006.
4. Matchonov S., Shojalilov A., Gulomova X., Sariev Sh., Dolimov Z. Textbook 4th grade: textbook for 4th grade of general secondary schools. - Revised and supplemented sixth edition. - Tashkent.: «New road polygraph service», 2017. - 216 p.
5. Umarova M., Khamrakulova H., Tadjibayeva R. Textbook 3rd grade: textbook for 3rd grade of secondary schools - Revised and supplemented sixth edition.- Tashkent .: «New road polygraph service», 2017. - 216 p.
6. People's Word Newspaper-T .: 14.01.2017
7. The library of [www.ziyouz.com](http://www.ziyouz.com)



**ACADEMICIA**  
**An International  
 Multidisciplinary  
 Research Journal**  
 (Double Blind Refereed & Peer Reviewed Journal)

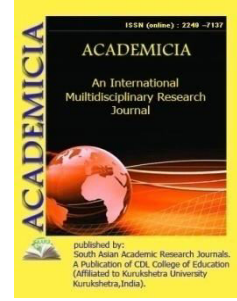

**DOI: 10.5958/2249-7137.2021.01926.1**

## USING RELIEF NOUNS IN THE ENGLISH DICTIONARIES

**Farmonov Bekzod Begmatovich\***

\*Tashkent State University of Uzbek,  
 Language and Literature named after Alisher Navoi,  
 UZBEKISTAN

### ABSTRACT

*The lexical features that perform these concepts also form a system of reliefs in the lexical layer of the language. The structure of the system of units representing the concepts of reliefs and the lexical units that make it up have their own structural, semantic, stylistic features in the lexicon of different languages. This study also serves as an important resource for the study of the formation of reliephonyms. It should also be noted that there are special dictionaries for the study of English geographical terminology. Various dictionaries on geographical terms have also been published, which form the basis for the study of the system of geographical terms in different systematic languages. While in the previous stage the same meaning served as a distinguishing meaning to distinguish them from other units of common meaning, in the next stage it acquires the status of a unifying meaning.*

**KEYWORDS:** *Mountain Ranges, Intermountain Depressions, Ridges, Lowlands, Meso Reliefs, Cliffs, Underwater Canyons, Hills, Micro-Relief, Cliffs, Hills, Steppe Hills, Etc.*

### INTRODUCTION

In particular, the units representing the reliefs are grouped into a separate lexical-semantic group in the English lexicon, which is also characterized by general and sectoral applications. When we talk about the study of relief and the lexical units that express it in English, which is one of the main sectoral concepts, it is necessary to list the works on the main issues of terminology. Because the word relief is mainly considered as a geographical term. Therefore, it is expedient to study the issue of general reliefs in conjunction with the study of geographical terminology. Relief (French, relief, lat. Relevo - I lift) (in geography) - various irregularities in terms of appearance, size, origin, age and history of development on the surface, ocean and seabed: mountains, plains, lowlands, hills, plateaus, hills, a set of hills, valleys, depressions, ravines, ravines and other lowlands. Reliefs are divided into the following categories according to their

size: megarelief (continental ridges, ocean floor), as well as slightly smaller forms (mountain systems, plains); macro relief (mountain ranges, intermountain depressions, ridges, lowlands); mesorelief (cliffs, underwater canyons, hills); micro-relief (depths, cliffs, hills, steppe hills, etc.); nano relief (very small pits, bumps, etc.). This division is conditionally separated. The external or morphographic features of R., which characterize important orographic units, as well as its quantitative properties, are not always a reliable basis for a complex assessment of reliefs, as the origin and development of forms with the same appearance may be different. Various dictionaries on geographical terms have also been published, which form the basis for the study of the system of geographical terms in different systematic languages. While in the previous stage the same meaning served as a distinguishing meaning to distinguish them from other units of common meaning, in the next stage it acquires the status of a unifying meaning. The semantic structure of reliefonyms belonging to this group can be generally defined as follows: "view of the earth's surface, the upper part of the earth's surface". If this semantic feature is common, the features of the semantic structure of the relief phrases belonging to the group "height" should be noted as follows: hill high-rise part". Such semantic diversity is an important factor in ensuring the independence and individuality of relief phrases.

Geographical terms have also been the subject of special monographic research. Reliefs in English have been studied in detail in a comparative aspect. For example, M. Asadova's monograph "Comparative structural-semantic and etymological analysis of geographical terms in the Tajik and English languages" features, structural (word formation) features of the geographical dictionary in English and Tajik, morphological method of formation of geographical terms in Tajik and English, assimilation of geographical terms, morphological and syntactic methods of formation of geographical terms are studied.

The dissertation also analyzes lexical-semantic groups of geographical terms in the analyzed languages, issues of polysemy and homonymy in geographical terminology, etymological analysis of some geographical terms in English.

D.R. Khairutdinov's dissertation on "Geographical terminology: Arabic, Russian, English parallels" concretizes the concept of "geographical term", text linguistics and lexical analysis of sources, geographical maps of Arab scholars, correspondence and textbooks on geography in various geographical areas of the Arab world. Terms, their origin and semantics; to determine their phonetic evolution from the Middle Ages to the present day; analysis of geographical terms in English and Russian, geographical terms, their English and Russian equivalents; identify the main problems in the translation of Arabic geographical terms, study the terminology of English and Russian languages, the problem of their unification and standardization; devoted to the solution of problems such as the study and comparison of geographical terminological dictionaries.

M.Kh. Murodbekova in her dissertation "System of geographical terminology in Russian and Tajik languages" to distinguish geographical terminology, which is part of the general vocabulary of the Tajik and Russian languages; Defining the terminological structure of nouns, adjectives and other word groups in the system of geographical terminology of the Tajik and Russian languages; structure of the system of geographical terminology in comparable languages and description of its functional elements; issues such as inventory and description of terminology involved in the formation of geographical terminological units have been explored. Ms. Baghdasaryan in his monograph "Derivational paradigmatic of geographical terminology



(terms of physical geography)" methods of making simple and complex physical geography terms; substantiate the role of the basic morpheme / terminoelement in the formation of geographical terms; drew our attention to the fact that it is devoted to the study of issues such as the analysis of the place of a geographical one-word term in the word-formation hub.

Z.S.Kamaletdinova's "Turko-Tatar geographical terminology and toponymy of the Tomsk region of the Russian Federation" The research is devoted<sup>1</sup> to the study of the system and semantics of geographical terms, which helps us to determine the system of relief phrases in English and Uzbek. N.V. Ushkova's research "Features of the formation of terminology" relief of the earth's surface "in English and Russian languages" The main issues of modern terminology (the term and its place in the language, the relationship between the term and the word); historical and diachronic analysis of the studied terms (the concept of "relief", the dynamics of development of the terminology "relief" in English, the oldest period, the Middle Ages, the New England period, the 18th century English vocabulary related to the concept of "relief" development of English vocabulary related to the concept of "relief" in the 19th century, the current state of the English dictionary in the early twentieth century, the dynamics of development of the terminology "terrain relief" in Russian: the period of common Slavic, Old Russian (East Slavic), modern Russian period).

At the same time, N.V. Ushkova, conducting a comparative analysis of relief terminology in Russian and English, noted that the semantic relationship between lexemes in Russian and English terminology under analysis: synonymy, antonymy, polysemy, homonymy, hyponymia even analyzes paronymy issues. The study also provides a structural analysis of the system of terminology for "relief" in Russian and English: one-word, two-word, three-word, four-word terms are grouped.

At the same time, N.V. Ushkova, conducting a comparative analysis of relief terminology in Russian and English, noted that the semantic relationship between lexemes in Russian and English terminology under analysis: synonymy, antonymy, polysemy, homonymy, hyponymia even analyzes paronymy issues. The study also provides a structural analysis of the system of terminology for "relief" in Russian

"Semantics and structure of Russian general geological terminology",The work of R.Yu.Kobrin's "Experience in linguistic analysis of terminology"his work on the subject is of interest in the study of geographical terms or the system of terms denoting reliefonyms.A.I. Komarova's "Philology of the English landscape"and M.A. Lazareva's "Comparative analysis of the meteorological vocabulary of the English and Russian languages"it is the system of relefononyms in English, the semantics of which are studies devoted to their comparative analysis.G.L.Panina is "Terminology and nomenclature of physical geography (on the material of the English language)" in his dissertation he studies the terminology and nomenclature of physical geography on the example of English language materials in a monograph.D.A. Timofeev in Russian Linguistics"Terminology of arid and aeolian relief formation: materials on geomorphological terminology"Several methods of formation of relief terminology in his monograph entitled, is rich in the fact that it provides rich materials on the terminology of geomorphology.This study also serves as an important resource for the study of the formation of reliephononyms.It should also be noted that there are special dictionaries for the study of English geographical terminology.

Among such dictionaries we have read the Glossary of Geographical Terms, D. Harper's Online Dictionary of Geographical Terms, and the Longman Geographical Dictionary. "Geographical terms and names as a component of phraseological units of the English and Russian languages" In the title course work, phraseology is a special layer of the lexical structure of the language, the classification of phraseological units, the linguistic and cultural significance of phraseological units, the comparative analysis of phraseological units containing geographical terms and names in Russian and English. Compiled by V.M. Kotlyakov, A.I. Komarova "Geography: concepts and terms: a five-language academic dictionary: Russian-English-French-Spanish-German" the dictionary serves as a rich linguistic material for our study, providing translation of geographical terms into five languages. This glossary of geographical terms includes five languages: Russian, English, French, Spanish, and German. Terms of 14 geographical sciences are included: general geography, physical geography and landscape, paleogeography, geomorphology, soil geography, biogeography, meteorology, climatology, land hydrology, glacier, permafrost science, socioinformatics, sociology, economics, oceanography, cartography geography. There are about 7,000 short descriptive terms in Russian and English, more than 1,000 basic synonyms, as well as a list of names of geographical objects and events, and an index of alphabetical and thematic terms in Russian as well as four languages: English, French, Spanish, and German.

Drawings, photographs are provided for the explanation of many (more than 500) terms and concepts. The dictionary is intended for geographers, geologists, ecologists and other environmental specialists, bachelors and graduate students of higher education institutions, school teachers, travel enthusiasts, naturalists. It is a rich source of material for researchers dealing with linguistics and terminology. Prepared for publication by V.M. Kotlyakov and A.I. Komarova "Russian-English Dictionary of Geographical Terms (with interpretations in Russian and English): About 7000 entries // Dictionary of Geography. With Definitions in Russian and English. About 7000 Geographic Terms" the dictionary is also a valuable source of linguistic information for the study of the system of English phrases.

This bilingual dictionary of geographical terms includes 14 geographies such as general geography, physical geography, paleogeography, geomorphology, soil geography, biogeography, meteorology and climatology, terrestrial hydrology, oceanology, cartography and geoinformatics, general geoecology. There are about 7,000 short-term terms in Russian and English. Indexes of Russian terms in thematic and alphabetical order, as well as alphabetical index of English terms are given. In his article entitled "Geographical Terminology" R. Marius gives some ideas about the semantic structure of English geographical terminology.

"Development of Geography and Geology Terminology in British Sign Language" The project is dedicated to the development of the terms geography and geology in the British version of the English language. This is what the project says about practice: "The BSL Glossary Project, run by the Scottish Sensory Centre at the University of Edinburgh focuses on developing scientific terminology in British Sign Language for use in the primary, secondary and tertiary education of deaf and hard of hearing students within the UK. Thus far, the project has developed 850 new signs and definitions covering Chemistry, Physics, Biology, Astronomy and Mathematics. The project has also translated examinations into BSL for students across Scotland. The current phase of the project has focused on developing terminology for Geography and Geology subjects. More than 189 new signs have been developed in these subjects including weather, rivers, maps,

natural hazards and Geographical Information Systems. The signs were developed by a focus group with expertise in Geography and Geology, Chemistry, Ecology, BSL Linguistics and Deaf hard of hearing students within the UK. Thus far, the project has developed 850 new signs and definitions covering Chemistry, Physics, Biology, Astronomy and Mathematics. The project has also translated examinations into BSL for students across Scotland. The current phase of the project has focused on developing terminology for Geography and Geology subjects. More than 189 new signs have been developed in these subjects including weather, rivers, maps, natural hazards and Geographical Information Systems. The signs were developed by a focus group with expertise in Geography and Geology, Chemistry, Ecology, BSL Linguistics and Deaf Education all of whom are deaf fluent BSL users”<sup>1</sup>. Namely: The BSL Glossary project, run by the Scottish Science Center at the University of Edinburgh, aims to develop scientific sign language in English sign language for use in primary, secondary and higher education by deaf and hard of hearing students in the UK. So far, the project has developed 850 new symbols and definitions, including chemistry, physics, biology, astronomy and mathematics. The current phase of the project is aimed at developing the terminology of geography and geological sciences. More than 189 new terminology definitions have been developed on this topic: they cover topics such as weather, rivers, maps, natural hazards, and geographic information systems.

#### LIST OF USED LITERATURE

1. Bagdasaryan M.S. Word-formation paradigmatics of geographical terminology (terms of physical geography): abstract of Ph.D. dissertation. Candidate of Philology. - St. Petersburg Dushanbe, 1991.-- 27 p.
2. Bessonova E.V. Semantics and structure of Russian general geological terminology. Abstract of thesis. dis. Cand. philol. sciences. - M., 1984. -- 17 p.; Kobrin R.Yu. Experience in linguistic analysis of terminology. Abstract of thesis. dis. Cand. philol. sciences. - Gorky, 1969.-- 21 p.
3. Development of Geography and Geology Terminology in British Sign Language. EGU General Assembly 2016, held 17-22 April, 2016 in Vienna Austria, id.
4. Kotlyakov V.M., Komarova A.I. // Kotlyakov V.M., Komarova A.I. Russian-English dictionary of geographical terms (with interpretations in Russian and English): About 7000 entries // Dictionary of Geography. With Definitions in Russian and English. About 7000 Geographic Terms Ed. 2. - URSS, 2021.-- 752 p.
5. Monkhouse F.J. A Dictionary of Geography. London, 1965. – 344 p.
6. Online Etymology Dictionary Douglas Harper. [http:// www.etymonline.com](http://www.etymonline.com)
7. Stamp D. Longmans dictionary of geography. –London, 1966. –492 p.

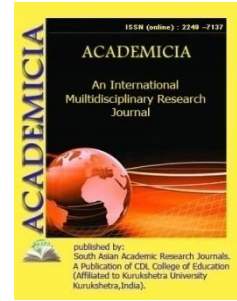

DOI: [10.5958/2249-7137.2021.01927.3](https://doi.org/10.5958/2249-7137.2021.01927.3)

## CAUSES, EARLY DIAGNOSIS AND FEATURES OF LATENT ENDOMETRITIS IN COWS

**B. M. Eshburiev\***

\*Professor Doctoral Student,  
M.Kh.Khamidov, UZBEKISTAN

### ABSTRACT

*This article provides information on the causes, early diagnosis, and transient characteristics of acute endometritis in cows. In this type of endometritis, infertility of cows is observed due to excessive amounts of mucus, which impedes the movement of sperm through the genital tract, as well as the lethal effect of uterine exudate on spermatozoa. During estrus, more fluid comes out of the uterus than usual, sometimes with an admixture of purulent exudate. Although females are regularly in heat and fertilize, they do not become pregnant.*

**KEYWORDS:** *Acute Endometritis, Diseases Of The Uterus, Colds And Purulent, Subinvolution Of The Uterus, Endometritis, Preventive Treatment, Ultrasound, The Index Of Sperm Entering The Female Cell.*

### INTRODUCTION

In recent years, the republic has paid great attention to the introduction of scientific achievements and advanced experience in improving pedigree livestock, enriching the gene pool, strengthening the fodder base and increasing production. To this end, it is important to identify, develop and recommend in practice the timely detection, prevention and treatment of endometritis, which is one of the most common obstetric and gynecological diseases in productive cows brought into the country from foreign countries in recent years.

According to the literature, the frequency of retention of the placenta among cows on dairy farms is 8.5%, clinical endometritis is 9.7%, and the effectiveness of treatment of these pathologies does not exceed 70-80% when the conditions for feeding animals deteriorate and ineffective treatment methods are used. Therefore, it is necessary to organize preventive treatment of these diseases without clinical manifestations, even in the latent period (B.G. Pankov, 2003).

The absence of an active mutation is a minor factor in the development of acute endometritis in cows: when it was observed that only 36.4% of cows had a normal lifespan, when cows were kept in one place for a long time, and 46.0% of cows had uterine inflammation in various forms. Of these, catarrhal - in 20.9% of cows, purulent-catarrhal - in 60.0% of cows, fibrin - in 12.1% of cows, necrotizing endometritis was observed - in 6.9% of cases (I.S.Koba, 2009). Endometritis often develops in a latent state without any clinical manifestations, which leads to long-term infertility of the animal (Eshburiev B.M., Khamidov M.Kh., 2013).

According to I.S. Koba (2003), in a seasonal study, acute endometritis in cows was recorded in 67.3% of cows in winter-early spring and 21.9% in summer. As a result, the process of sexual intercourse in the sperm of cows was delayed by an average of 47 days, and the fertility index increased by 1.2 times. After calving, infected cows had a mean time between sperm and female gametes of 156 days, 87 days longer than healthy cows.

According to R.G. Kuzmich (2000), as a result of contacting obstetric and gynecological dispensaries, 16.2% (13.8 - 19.9%) of newborns have retained placenta, 20.1% (17.9 - 36.2%) have subinvolution of the uterus in cows and 22.3% (18.5 - 38.1%) of endometritis in cows. Of these, 22.9% of cows in winter (22.4 - 23.3%), 23.5% in spring (23.1-23.8%), 16.6% in summer (12.9-20.4%) ) and 21.8% (20.2-22.8%) in autumn cows reported postpartum endometritis. That is, the incidence rate of endometritis in cows was the highest in the spring, here the main place was occupied with catarrhal endometritis after childbirth.

**Research object and methods.** An obstetric and gynecological dispensary was conducted to study the types, economic damage and characteristics of the transmission of endometritis in cows 5-6 years old, 70 Golishtinsko-Friesian breed, belonging to the "Dustlik" state farm of the Pstdargom region of the Samarkand region.

The level of satisfaction of the needs of the animal organism is studied on the basis of comparison with the food norms of the zootechnical analysis of the conditions of keeping cows, the composition and nutrition of the feed ration, the amount of digestible protein, sugar, calcium, phosphorus, carotene, clove, sugar-protein and phosphorus-calcium ratios in feed.

From the 2nd month of lactation in dairy cows, clinical examinations were carried out once every 3 days with an emphasis on general condition, appetite, obesity, and response to external influences. Conventional clinical examination methods were used to determine mucous membranes, skin and skin, musculoskeletal health, 5-minute anterior abdominal movement, body temperature, 1-minute heart rate, and respiratory rate. During an external gynecological examination, the state of the labia minora, the vaginal cavity, the discharge of the mucous membrane from the genital tract, the color of the vaginal mucosa, the state of the cervix were studied.

In cows with latent endometritis, ultrasound examination (USE) was carried out using the "AKU Vesta" device to determine the state of the uterus and ovaries of cows.

In blood samples of cows with latent endometritis, the number of erythrocytes and leukocytes (Goryaev's account), hemoglobin (Sali's hemometer), total serum protein (refractometric method), leucoformula (in Romanovsky-Giemsa smears) were detected once every 3 days.



**The results obtained and their analysis.** At “Dustlik” farm, milking cows are kept in one place, they lack active mating and sunlight. The cows are milked 2 times a day using milking machines. Average milk yield is 13-15 liters.

The ration of cows is silage-concentrate, containing 20 kg of medium quality silage (59.7%), 5 kg of alfalfa hay (14.9%), spring straw 5 kg (14.9%), soybean meal 0.5 kg (1, 5%), wheat porridge 1 kg (3%), cotton flour 0.5 kg (1.5%), barley porridge 0.5 kg (1.5%), corn porridge 1 kg (3%), consists of 11,425 food units, metabolic energy 144,465, dry matter content 16,450 g, 1.65 g less than normal, digestible protein 1976 g, crude fiber 4641 g, sugar 330 g, salt - 135.1 g, calcium and 43.25 g phosphorus, carotene 680.9 mg.

According to the results of clinical and gynecological examination of 70 cows belonging to the farm, endometritis was diagnosed in 14 cows (20%) of cows on the farm. Of these, acute catarrhal endometritis was detected in 3 cows (21%), acute catarrhal-purulent endometritis in 2 cows (15%), chronic purulent endometritis in 3 cows (21%) and latent endometritis in 6 cows (43%).

In cows with acute catarrhal-purulent endometritis, general weakness, decreased appetite, average body temperature  $0.5-1^{\circ}\text{C}$ , increased heart rate - 10-15 times per minute (on average for 1 minute - 82.2 times), on average, there was a decrease in the number of contractions in 5 minutes up to 6.1 times (the norm is 8-12 times in 5 minutes), pallor of the mucous membranes (anemia) and cyanosis, catarrhal-purulent exudate from the vagina, episodic discomfort and tension.

Ultrasound examination of cows with catarrhal-purulent endometritis through the rectum was characterized by a delay in catarrhal-purulent exudate in the uterine cavity, thickening of the uterine wall, unevenness of the mucous membrane, subinvolution of the uterus, preservation of the corpus luteum in the ovaries of the uterine cavity.

Cows infected with latent endometritis show no clinical signs between estrus and no abnormal changes are found on rectal or vaginal examination. During estrus, more fluid comes out of the uterus than usual, sometimes with an admixture of purulent exudate. Although cows are regularly in heat and inseminated, sperm does not enter the female reproductive cell. In this type of endometritis, infertility of cows is observed due to excessive amounts of mucus, which impedes the movement of sperm through the genital tract, as well as the lethal effect of uterine exudate on spermatozoa.

The average hemoglobin in the blood of cows with acute endometritis is up to  $70 \pm 0.12$  g / l compared to the physiological norm, the number of erythrocytes - up to  $4.1 \pm 0.47$  million /  $\mu\text{l}$ , total protein - up to  $7.7 \pm 1$ , 37 g / l and an increase in the number of leukocytes to  $13.2 \pm 2.34$  thousand /  $\mu\text{l}$ . In cows with acute endometritis, a decrease in the number of erythrocytes and hemoglobin, total protein, can be explained by the absorption into the blood of toxins released by microorganisms from the focus of inflammation.

It was noted that the number of leukocytes in the blood of cows increased by thousands /  $\mu\text{l}$  compared with the norm. These indicators indicate an increase in the activity of the leukopoietic apparatus in acute catarrhal-purulent endometritis.

When studying leukoformula in cows with acute endometritis, the percentage of granulocytes was 2.92% higher than the physiological norm, averaging 39.63%. The increase in the



percentage of granulocytes was mainly due to basophils and eosinophils, with a decrease of 7.37% compared with the control group of neutrophils.

In sick cows, the leuko-formula index is mainly due to an increase in basophils up to 2.1% (the norm is 0-0.2%), stab neutrophils - 21%, monocytes - up to 17% and eosinophils - 1%, segmental nucleus neutrophils - 7.%, lymphocytes - characterized by a decrease of up to 51.9%. This indicates acute inflammatory processes that occur when the nucleus is displaced to the right.

Ultrasound examination (USE) in cows was characterized by the accumulation of catarrhal-purulent exudate in the uterine cavity, diphtheria changes in the mucous membranes of the uterus and cervix, thickening of the uterine wall, preservation of the corpus luteum in the ovaries.

### CONCLUSIONS:

1. The main etiological factors in the development of endometritis in cows are incomplete satisfaction of the body's needs for nutrients, vitamins, macro- and microelements, a low ratio of sugar-protein and phosphorus-calcium in the diet, lack of diffusion and sunlight and unsanitary storage of a cow and the sexual transmission of various microorganisms. Among cows with endometritis in cows 20%, of which acute catarrhal endometritis - 21%, acute catarrhal-purulent endometritis - 15%, chronic purulent endometritis - 21% and latent endometritis - 43%.

2. Acute catarrhal-purulent endometritis in dairy cows leads to a decrease in appetite, whitening and cyanosis of the mucous membranes, an increase in pulse rate by 10-15 times per minute, an increase in body temperature by an average of 0.5-1<sup>0</sup>C, an average contraction of the anterior gastrointestinal tract - 6.1 times in 5 minutes. characterized by a decrease in catarrhal-purulent exudate from the vagina, uterine suinvolution, episodic discomfort and tension, delayed catarrhal-purulent exudate in the uterus on ultrasound, thickening of the uterine wall, preservation of the corpus luteum in the ovaries.

3. When diagnosing latent endometritis in sick cows, no clinical signs are observed between estrus, and no abnormal changes are found during rectal and vaginal examinations. During estrus, more fluid comes out of the uterus than usual, sometimes with an admixture of purulent exudate. Although females are regularly in heat and fertilize, they do not become pregnant. In this type of endometritis, infertility of cows is observed due to excessive amounts of mucus, which impedes the movement of sperm through the genital tract, as well as the lethal effect of uterine exudate on spermatozoa.

### LIST OF USED LITERATURE:

1. Dyulger G.P., Khramtsov V.V. and others, Medicines used in veterinary obstetrics, gynecology, andrology and animal reproduction biotechnology: A reference guide. - SPb. : Publishing house "Lan", 2016, - 272 p.
2. Koba I.S. Prevention and therapy of endometritis in cows / I.S. Koba, A.N. Turchenko // Information sheet 2003.
3. Pankov B.G., Zharov A.V. Prevention, pharmacoprophylaxis, early diagnosis, treatment of clinical and latent endometritis in cows. \ Methodical recommendations approved by the Veterinary Department of the Ministry of Agriculture of the Russian Federation. (28.02.02 No. 13-5-02 / 9), M., 2003.

4. Kuzmich R.G. Postpartum endometritis in cows (etiology, pathogenesis, prevention and therapy). Abstract of the dissertation of Doctor of Veterinary Sciences. Vitebsk, 2000, p. 12-13.
5. Sokolova O.V. Assessment of the bioresource potential of highly productive cows with different housing technologies. Abstract of the dissertation of the candidate of biological sciences. - 2007.p.19.
6. Studentsov A.P., Shipilov V.S., Nikitin V.Ya. other. Veterinary obstetrics, gynecology and reproduction biotechnology. Moscow, Kolos, 1999.
7. Eshburiev B.M. Veterinary obstetrics. Tashkent, Science and Technology Publishing House, 2018.

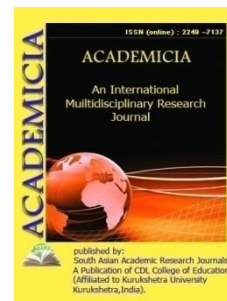
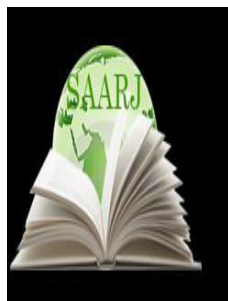

DOI: [10.5958/2249-7137.2021.01928.5](https://doi.org/10.5958/2249-7137.2021.01928.5)

## CATEGORY OF INFORMATIVITY IN VISUAL POETIC TEXTS

Yunusova Hilola Ravshan kizi\*

\*Teacher,  
English language department Fergana State University Fergana,  
UZBEKISTAN

### ABSTRACT

*The article discusses informativity as the main category in visual poetic texts, as well as the types of information that are visualized in them. The information types that can be embodied through visual means are factual, conceptual and subtextual and they are analyzed on the examples of Uzbek visual poetic texts. In doing so, the scientist investigates not only the message delivered through the verbal component of the poetic text, but also the types of information that are to be conveyed to the recipient through other semiotic codes. This is often due to his or her inability to use the tools needed for linguistic analysis or his general thesaurus, i.e. the perceiver has a lack of understanding of belles-lettres and does not have the necessary experience in evaluating them.*

**KEYWORDS:** *Visual Poetic Texts, Category Of Informativity, Content-Factual Information (CFI), Content-Conceptual Information (CCI), Content-Sub Textual Information (CSI).*

### INTRODUCTION

While many researchers study the category of informativity in different functional styles and types of texts, they view it as a universal characteristic peculiar to the text, while at the same time distinguishing between different types of information in the text. A. Mol in his scientific work proposes to distinguish semantic and aesthetic information types [5]. L. V. Fyodorova acknowledges the source and retrospective types of information [2]. According to E. I. Golubeva, the information in the text can be objective or subjective [4]. For our research, the typology of information proposed by I. R. Galperin is important. The scientist considers informativity as one of the main categories of the text and recognizes that there are three types

of information according to its pragmatic function: content-factual information (CFI), content-conceptual information (CCI), content-sub textual information (CSI) [3].

There are many readers who, when reading a work of art, cannot go beyond understanding the factual information in it. This is a frequent occurrence, especially, in the process of reading poetic texts. In this case, the conceptuality of the text becomes an incomprehensible factor for the reader. This is often due to his or her inability to use the tools needed for linguistic analysis or his general thesaurus, i.e. the perceiver has a lack of understanding of belles-lettres and does not have the necessary experience in evaluating them. But, at the same time, readers who have extensive experience in interpreting the idea put into the work of art may also have different understanding of conceptuality, that is, the basic information that is to be delivered.

Usually the CFI lies on the surface of the message sent by the author to the recipient and then serves as a basis for additional meanings that are “linked” to it [7, 87]. Through the CFI, events, processes related to the past, present and future are described to the recipient in a logical way.

CCI is a type of information that reflects the author’s idea and is described through CFI. The difference between CFI and CCI is that the information in the former is of a common nature and the latter is of an artistic-aesthetic nature. Nevertheless, I. R. Galperin argues that CFI can reflect real or imaginary reality[3, 28].

Conceptual analysis of a literary text means: 1) identification of a set of keywords (leitmotiv words, lexical dominants) in the text; 2) definition of the general concept (concepts) of the text; 3) description of the conceptual field of the text [1, 59]. The role of a number of expressive means such as metaphor, metonymy, simile, in the emergence of CCI in the literary text is incomparable.

The concept of the text, on the one hand, is the main idea of the author and, on the other, the semantic interpretation of the main idea. Different readers will have different viewpoints about the conceptual information of the same text [8].

Almost all works of art have a subtext. “Subtext is a purely linguistic phenomenon, arising from the ability of sentences to create additional meaning due to various structural features, the specificity of the interconnection of sentences, the symbolism of linguistic facts. A theme and rheme relationship is established between the text and subtext meanings. The text meaning is a theme (the meaning given in the text); subtext is a rheme (new meaning). The peculiarity of the subtext is that it is not directly observable, it is ignored in the first reading (of the text), it is reflected in the content-factual information through repeated and even multiple-time reading”[3,44].

In general, CFI is a type of information that is clearly stated in the text; CCI is the main idea of the text, its main content; CSI is a hidden meaning in the text.

Based on the typology presented by I. R. Galperin who identifies the type of information in poetic and prosaic texts and elaborates on its analysis, K. A. Sloutskaya studies the same types of information on the example of visual poetic texts [7]. In doing so, the scientist investigates not only the message delivered through the verbal component of the poetic text, but also the types of information that are to be conveyed to the recipient through other semiotic codes. As I. R. Galperin points out, “In fiction, form often has a specific meaning. The form itself contains a certain, and in some cases very important, part of the information ... This type of information,

which is not expressed verbally, has a special feature: it is perceived differently by the receiver, unless the receiver understands the content of the sentence and its form of expression. Of course, if he is able to understand this information through analysis at all”[3, 30].

Following I.R. Galperin and K. A. Sloutskaya, we have also intended to analyze some visual poetic texts in the Uzbek language, which include content-factual, content-conceptual and content-sub textual types of information.

A distinctive feature of CFI visualization is the recipient’s attitude towards this type of work: they cause a smile and evoke a positive mood. We can see the visualization of factual information in A. Akbar's visual poetic texts in the series of poems titled "Poetic Lessons from Drawing" (“Rasmdanshe’riysaboqlar”), because it is in this way that it is easier for children to "digest" information. Each image in the text repeats the parts of the verbal text. The same phenomenon can be observed in D. Rajab's poem "Witness" (“Guvoh”). However, unlike the previous visual poetic text, the CFI visualized through linguistic elements does not belong to the whole text, but covers only a part of the text. More precisely, only the last two lines of the verbal text are visualized.

The visual-graphical reflection of CFI is mainly reflected in children's poetry. This is due to the fact that young children’s cognitive abilities are not sufficiently developed to understand content-conceptual and content-subtextual information.

The text of D. Rajab's poem "Literature" (“Adabiyot”) is accompanied by a visual image of the clock, which reflects the poet's attitude to literature. The verbal component of this text cannot be said to be connected with its visual perception on the basis of a content-factual relationship. Because, although the poetic text speaks of the rotation of the clock hands, the main idea is not to describe the clock, but the passage of time, the change of time. The picture of the clock in the text is a symbol of eternity. Through the image of the clock and the graphemes surrounding it the author wants to emphasize that literature is an "immortal art form", and even if the person, namely, the writer dies one day, and if his works have a great value in terms of their content and aesthetics, they will not lose their worth over time.

It should also be noted that a particular literary text may deliver not only one type of information, but several distinct kinds of information. I. R. Galperin calls such texts as "correct texts." That is, he acknowledges that the correct texts are based on the harmonious relationship of CFI, CCI and CSI [3, 25].

The main difference between conceptual and subtextual information is that conceptual information belongs to the whole text. It forms the main idea of the work. The subtext may be hidden behind the factual information in some part of the text. Another difference is that the interpretation of CSI in visual poetic texts may vary from person to person. It cannot be assumed that some interpretations of text are correct and other ones are wrong. All of them have equal right to exist.

Decoding a visualized CSI is a much more complex process. In this case, the life experience of the interpreter, that is, the person who carries out the interpretation of poetic text, the level of interest in literature, the amount of basic knowledge, values, the concepts that have become a priority for him or her are important. As K. Sloutskaya points out, “The author cannot predict all the nuances of the interpretation of such a visual poem because he does not know (in advance)

what kind of reader will be interested in it" [7, 173]. We want to prove the multi-vector nature of this interpretation process with an example from Fakhriyor's "Geometric Spring" ("Geometrikbahor"). Pragmatic analysis of this visual poetic text has already been done by the linguist U. Nosirova, and according to her, the "rectangle" in that poetic text represents human's life, the "triangle" represents the annual shortening of human's life, the "X" is a shortened form of human chromosomes, and the colored rectangle described by the poet as "a green garden" means a physically and spiritually healthy generation. This interpretation can be accessed in more detail in U. Nosirova's monograph [6, 121-122]. However, the idea that all recipients should interpret the text this way, and not that way, is quite wrong. In this regard, we consider S. Kuronov's opinion to be appropriate: "Let us remember "the rectangle" and "the triangle" mentioned at the beginning of the poem. They can be interpreted differently by each reader. But is there anyone who can fully explain the aesthetic value of characters and the content they represent? No, because their only function is to influence without expressing any specific content, and everyone gets different results from this impact. That is, here we come across a different type of image that differs from the traditional image, which has the same core, the aesthetic core - the ore, which is embodied in the hearts and minds of most people" [9].

In this regard, we would like to present our own interpretation here. In our opinion, by "the empty rectangle" the poet implies to his native village Sangijumon. The name of this place appears many times in the poems of the author. Under the image of "spring" lies the author himself, who returned to his native village, longing for his youth. For some reason it turns into a "triangle". This is because the author's vision of the world today is different from that of in his youth. The young boy who idealized the world, the events in it, the people around, has grown up and suffering the pains he has realized that life is not that perfect. His "rectangular" attitude to life as a child and his "triangular" views today are inconsistent. Here one can feel that rural and urban lives are in conflict with each other.

As the author returns to his native village, he witnesses a clash of past and present there. He explains this with the phrase "the garden actually consists of two springs". That is, the first spring - the present, longing for youth (the one, returned), and the second spring - the author's past, memories of youth (the one, wintering under the snow). When these two springs collide (merge), that is, when the poet returns to the place where he was born and grew up, albeit in a dream, when he reminisces the carefree years of his childhood, happy-go-lucky days, he feels happy (the garden turns green).

Apparently, if the recipient's imagination is allowed to flow, different interpretations will emerge. This is especially true for the texts where CSI is visualized. "Thus, the reader reveals the meaning of the symbol, realizes the subtext of the work and the feeling that embraces him at this moment, is comparable to the feeling of enlightenment and at the same time admiration for the wisdom and creativity of the authors" [7, 175]. However, it should not be denied that there may be readers who do not understand CCI or CSI in the visual poetic texts, do not perceive what the author is trying to convey, and, on par with this, have negative opinions about the text and the author due to their limited imagination.

#### REFERENCES:

1. Babenko L. G., Kazarin Yu. V. Linguistic analysis of literary text. Theory and practice: textbook; workshop. Moscow: Flinta: Nauka, 2005. 496 p.



2. Fedorova LN Repetition as a means of forming the category of retrospection in a literary text / LN Fedorova // Collection of scientific works of the M. Torez Moscow State Pedagogical Institute of Foreign Languages. - 1984. - No. 228. - P. 111-121.
3. Halperin, I.R. Text as an object of linguistic research. 3rd ed., Stereotype. Moscow: Editorial URSS, 2005.144 p.
4. Golubeva, EI Correlation of different types of information in the text of autobiography / EI Golubeva // Collection of scientific works of the M. Torez Moscow State Pedagogical Institute of Foreign Languages. - 1986. - No. 263. - P. 66–75.
5. Mol, A. Information theory and aesthetic perception / A. Mol // - M .: Publishing house "Mir", 1966. - 99 p.
6. Носирова, У. И. Pragmatic features of poetic texts / Monograph / "Classic", 2020. - 156 p.
7. Slutskaya, KA Structural and semiotic aspects of Russian and English visual poetry: dis. ... Cand. philol. sciences. Tyumen, 2011 .-- 199 p.
8. <https://helpiks.org/8-62999.html>
9. <https://quronov.uz/%D1%88%D0%B5%D1%8A%D1%80%D0%B8%D1%8F%D1%82%D0%B4%D0%B0-%D1%88%D0%B0%D0%BA%D0%BB%D0%B8%D0%B9-%D0%B8%D0%B7%D0%BB%D0%B0%D0%BD%D0%B8%D1%88%D0%BB%D0%B0%D1%80/>

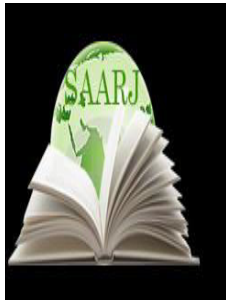

**ACADEMICIA**  
**An International  
 Multidisciplinary  
 Research Journal**  
 (Double Blind Refereed & Peer Reviewed Journal)

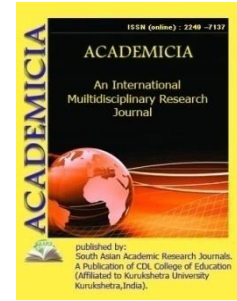

**DOI: 10.5958/2249-7137.2021.01929.7**

## INTERNATIONAL COOPERATION OF THE REPUBLIC OF UZBEKISTAN IN THE CONTEXT OF REGIONAL ENVIRONMENTAL PROTECTION

**Ismoil Nurmetov\***

\*Doctoral Student,  
 Department of History, Urganch State University,  
 Urgench, UZBEKISTAN  
 Email id: ismoil\_nur84@mail.ru

### ABSTRACT

*In this article, some of the issues of international cooperation of the Republic of Uzbekistan in the context of environmental protection activities in Central Asia have been observed. Since the early 2000s, a project has been implemented in Uzbekistan, with the support of UNDP, aimed at increasing the level of environmental monitoring and reporting in support of a more effective environmental policy. In the past two years, Uzbekistan has taken some measures to mitigate the socio-economic and environmental consequences of the Aral Sea disaster. Today, the Republic of Uzbekistan fulfills its obligations to achieve the UN Sustainable Development Goals, recognizing their importance and relevance in the context of national sustainable development.*

**KEYWORDS:** *Cooperation, Environment, The Aral Sea Problem, Sustainable Development.*

### INTRODUCTION

In the countries of the world, environmental degradation leads to huge costs, hinders socio-economic development. Degradation of the natural resource base (soil, water resources) negatively affects agricultural production. Air pollution and poor water quality in water supplies pose serious health risks. The importance of environmental quality for development has been reflected in the Millennium Development Goals<sup>1</sup>.

Biodiversity is a common good that belongs to all people on Earth. Biodiversity and its ecosystems are also important in terms of national development goals, including sustainable livelihoods. Matching the goals of land use, construction and economic development with the goals of protecting biodiversity and supporting ecosystems will enable countries to both preserve their rich natural heritage and enhance the well-being of their citizens<sup>2</sup>.

The species diversity of flora and fauna is directly dependent on the state of ecosystems. Due to its geographical and climatic features, the Republic of Uzbekistan is also subject to the influence of negative environmental factors, including transboundary ones, especially due to the fragility of arid and mountain ecosystems and limited water resources. Currently, 91 species of fauna are included in the International Red Book, 324 species of flora and 184 species of fauna are included in the Red Book of the Republic of Uzbekistan. As of January 1, 2019, the forest fund of the Republic of Uzbekistan was 11 572.6 thousand hectares, or 25.7% of the country's territory, including 3 201.6 thousand hectares covered with forest<sup>3</sup>.

Sustainable development of the Central Asian region is inseparable from regional cooperation, primarily on environmental protection and water resources management. Transboundary water cooperation in Central Asia is carried out both on the basis of bilateral and multilateral formats.

It should be emphasized that pursuing an active regional policy, creating a favorable political atmosphere in Central Asia, building constructive and mutually beneficial relations with the countries of the region, strengthening regional security and stability are the main priorities of Uzbekistan's foreign policy.

The President of the Republic of Uzbekistan Sh. Mirziyoyev in his speech at the 72<sup>nd</sup> session of the UN General Assembly, speaking about the problems of ensuring security and stability in Central Asia, said that such an important issue as the joint use of the region's common water resources cannot be ignored<sup>4</sup>. The head of the state also expressed his conviction that there is no alternative to solving the water problem, taking into account the interests of the countries and peoples of the region equally. Therefore, Uzbekistan supports the draft conventions on the use of water resources of the Amu Darya and Syr Darya river basins, developed by the UN Regional Center for Preventive Diplomacy.

It should be noted that the formation of Uzbekistan's foreign policy is inextricably linked with the process of strengthening its statehood, the development of socio-economic reforms, the creation of a democratic legal basis for Uzbek society that arose after the collapse of the USSR. Adhering to the principle of many vectors, Uzbekistan established relations with all in the 90s of the 20<sup>th</sup> century, reputable international organizations<sup>5</sup>.

Cooperation in the field of ensuring global and regional security is an important area of interaction between Uzbekistan and the UN. In this area, the Head of State draws attention to an acute and urgent global problem – the tragedy of the Aral Sea and calls for the world community to focus its efforts on “reducing the destructive impact of this environmental disaster on the livelihoods of millions of people living in Central Asia and preserving the natural and biological balance in the Aral Sea region”<sup>6</sup>.

The environmental problems of Central Asia are diverse. They arose in the region due to the active influence of man on nature: here more than a hundred years ago they began to intensively develop natural resources, developing the economy, agriculture, and energy. Of course, the Aral Sea disaster is one of the global environmental problems.

The drying up of the Aral Sea has led to the emergence of a permanent environmental hazard and negative impact on the quality of life and health of the entire population of the Aral Sea region. The Aral Sea crisis zone directly covers the territories of Turkmenistan, Kazakhstan and Uzbekistan, as well as indirectly – Tajikistan and Kyrgyzstan. Under the influence of the Aral

crisis, the area of meadows here has recently significantly decreased. More than 100,000 jobs have been lost due to declining soil fertility, resulting in a loss of sources of income for most families and farms in the region.

The Aral Sea region was a region with a great variety of flora and fauna, about 40 kinds of fish and a number of rare animal kinds lived in the water bodies of the Aral Sea region, the number of saighaks (a type of resistant plants which rises near the Aral Sea) reached 1 million heads, the floristic composition was about 640 plant kinds. Until 1960, the Aral Sea was one of the largest closed water bodies in the world with an area of about 70 thousand km<sup>2</sup> and a water volume of 1083 km<sup>3</sup>, its length was 426 km, width – 284 km, maximum depth – 68 m.

Intensive withdrawal of water from the Amu Darya and Syr Darya for irrigation in recent times has caused a drop in sea level. Over five decades, the area of the Aral Sea has decreased by 8 times, the volume of water has decreased by 14 times, it has moved 120-200 km from the coast. Salinization of water reached 110-112 g / l in the western part, and 280 g / l in the eastern part. At the bottom of the dried up sea, a saline valley has formed, the total area of which is 45 thousand km<sup>2</sup>.

As you know, the heads of the independent states of the region from the very beginning drew attention to the state of the Aral Sea, and the associated environmental disaster. Realizing that it was impossible to fight this phenomenon alone, they began to consult with each other to find ways out of this situation. Already in 1992-1993, political issues uniting the Central Asian “five” also emerged: thus, five-sided structures in the field of water use were created<sup>7</sup>.

As a result of the negotiations, on February 18, 1992, an “Agreement on joint management of the use and protection of water resources of interstate sources” was signed. Within the framework of this Agreement, the Interstate Water Coordination Commission (ICWC) was formed with the executive bodies of the BWO “Syr Darya”, BWO “Amu Darya”, the Scientific Information Center (SIC ICWC) and the Secretariat.

A significant event in this regard was the creation of the International Fund for Saving the Aral Sea (IFAS) in 1993, the founders of which were Kazakhstan, Kyrgyzstan, Tajikistan, Turkmenistan and Uzbekistan. In order to prevent the negative consequences of the Aral problem within the framework of IFAS, three Programs to provide assistance to the countries of the Aral Sea basin were implemented (ASBP-1, ASBP-2, ASBP-3).

Uzbekistan, being a key founding state of IFAS, attaches great importance to the comprehensive strengthening of its activities. During the Summit on Sustainable Development in September 2015 in New York, the Uzbek side came up with an initiative to create a special Trust Fund for the Aral Sea under the auspices of the United Nations on the Aral Sea zone, the main task of which will be the coordination of efforts and the implementation of targeted programs and projects.

Today, IFAS remains the only regional structure that has united the countries of the region on issues of water use and sustainable development. Uzbekistan considers the Fund as a real platform for the implementation of joint initiatives, programs and projects to reduce the negative consequences of the Aral Sea crisis.

On August 24, 2018, the President of the Republic of Uzbekistan Shavkat Mirziyoyev took part in the meeting of the Council of Heads of the IFAS Founding States (Turkmenbashi,

Turkmenistan). The head of the state highly appreciated the initiatives implemented during the chairmanship of Turkmenistan in the International Fund for Saving the Aral Sea, and noted that the projects and efforts of Uzbekistan and Turkmenistan in this area complement each other<sup>7</sup>.

It should be noted that large-scale projects are being implemented in Uzbekistan to stabilize the environmental situation, improve the living conditions of the Aral Sea population. In the past two years, Uzbekistan has taken some measures to mitigate the socio-economic and environmental consequences of the Aral Sea disaster. On the dried seabed, 461 thousand hectares have been sown with saxual seeds, furrows have been prepared for planting seedlings of salt-tolerant plants on an area of 1.1 million hectares<sup>8</sup>. These and other measures are aimed at countering the removal of dust and salt from the dried seabed, mitigating the impact of climate warming in the region on the environment and public health<sup>9</sup>.

Since the early 2000s, a project has been implemented in Uzbekistan, with the support of UNDP, aimed at increasing the level of environmental monitoring and reporting in support of a more effective environmental policy. Several joint bodies have been established in Central Asia in order to promote information exchange between monitoring and evaluation organizations. The Hydrometeoro-logical Service of Uzbekistan performs the functions of an information and communication center – it maintains general data and provides hydrometeorolo-gical data, information on the level of pollution of water resources and forecasts to consumers of such information in neighboring countries. In addition, the Central Asia Regional Water Sector Information Base (CAREWIB) project is a useful base that collects information on the state of affairs in the field of water resources management in the Aral Sea basin<sup>10</sup>.

Significant progress should be noted in the establishment and organization of advisory councils with the participation of non-governmental organizations (NGOs). NGOs play a critical role in environmental protection and sustainable development, drawing the attention of governments and society to urgent and emerging environmental issues around the world. For example, joining efforts of CAREC with NGOs is a prerequisite that will help them to pool resources and more actively represent the interests of the region on domestic and international negotiation platforms to solve environmental problems in Central Asia.

The Regional Environmental Center for Central Asia (CAREC) is a leading regional knowledge center in the field of environment and sustainable development, recognized by national, regional and international partners. This organization was established in 2001 by the governments of five Central Asian countries, as well as the European Union and UNDP in accordance with the decision of the 4<sup>th</sup> Pan-European Conference held in 1998 in Aarhus (Denmark)<sup>11</sup>.

Since its inception, promoting environmental cooperation and sustainable development in Central Asia, CAREC has developed into a regional organization. The governments of Central Asian countries, including the Republic of Uzbekistan, view CAREC as a unique platform that allows them to participate in international environmental processes, increase their potential in gaining access to international financing mechanisms in the field of climate change and biodiversity, and assist in promoting such regional governance models in environmental protection, as the Executive Committee of the International Fund for Saving the Aral Sea (EC IFAS) and the Interstate Commission on Sustainable Development (ICSD).

CAREC works in five directions. The first is related to climate change and energy efficiency issues. The second – with the environment, where the value of the surrounding world is

---

considered in terms of its renewability, ecological functions, the issues of the relationship between water and energy are studied. The third is education, where various possibilities are considered for educating the new generation in the spirit of the correct concept and perception of nature and care for the environment. The fourth is water cooperation. And the fifth block is health and the environment<sup>12</sup>.

Today, the Republic of Uzbekistan fulfills its obligations to achieve the UN Sustainable Development Goals, recognizing their importance and relevance in the context of national sustainable development. To achieve these goals, a number of strategic documents have been adopted in the country in recent years: the Action Strategy for the five priority areas of development of Uzbekistan in 2017- 2021, the Strategy for the transition to a “green” economy, the Strategy for the further development and reform of the electric power industry of the Republic of Uzbekistan, the Concept of environmental protection of the Republic of Uzbekistan until 2030<sup>13</sup> and others.

The Republic of Uzbekistan is part of a worldwide movement to mitigate and relieve modern environmental challenges such as ozone depletion, climate change, prevention of desertification and land degradation.

#### REFERENCES:

1. President of Uzbekistan Shavkat Mirziyoyev spoke at the 72<sup>nd</sup> session of the UN General Assembly. 20.09.2017. // [www.uza.uz](http://www.uza.uz)
2. The concept of environmental protection of the Republic of Uzbekistan until 2030 // [www.lex.uz](http://www.lex.uz)
3. Davletov S.R. Environmental issues in Uzbekistan at the modern stage of development // ACADEMICIA: An International Multidisciplinary Research Journal. Vol. 10 Issue 5, May 2020. P. 1775-1780.
4. Measures to Improve Environmental Policy: Progress in the Eastern Europe, Caucasus and Central Asia Region. OECD, 2007. // [www.sourceoecd.org](http://www.sourceoecd.org)
5. National database of legislation, October 31, 2019, No. 06/19/5863/3979.
6. Nishanov D.B. Foreign policy of the Republic of Uzbekistan in the 90s of the 20<sup>th</sup> century. Abstract of thesis of PhD, – Moscow, 2008.
7. Petrenko T. Экология – проблема региональная. // *Экономическое обозрение* (Ecology is a regional problem. // Economic Review), No. 12, 2018
8. Promotion of water, energy and food security in Central Asia. Nexus Bulletin No1. RECZA, 2019. – P. 3.
9. Cooperation of Uzbekistan with the United Nations // [www.mfa.uz](http://www.mfa.uz)
10. Regional cooperation in solving the Aral problem reaches a new level 25.08.2018. // [www.mfa.uz](http://www.mfa.uz)
11. Troitsky E.F. (Центральная Азия в системе международных отношений) Central Asia in the system of international relations (1992 - 2009). Abstract of thesis of Doctor of History. – Tomsk, 2010.



**12.** Millennium Development Goals, 2015 // [www.un.org](http://www.un.org).

**13.** The Ecological Party of Uzbekistan stands for the development and deepening of international cooperation in all spheres of life! 12/14/2019. // [www.pv.uz](http://www.pv.uz)

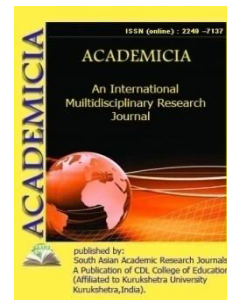
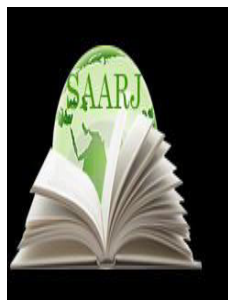

DOI: **10.5958/2249-7137.2021.01930.3**

## PRINCIPLES OF ORGANIZING THE SPIRITUAL – ENLIGHTENMENT ACTIVITIES OF FUTURE TEACHERS

**Rakhimov Asomiddin Anorboevich\***

\* Doctor of Philosophy in Pedagogy,  
Samarkand Regional Center for Retraining and Advanced,  
Training of Public Educators, UZBEKISTAN  
Email id: [asomiddin22@mail.ru](mailto:asomiddin22@mail.ru)

### ABSTRACT

*This article provides information on the specific factors of preparing future teachers for spiritual –enlightenment activities, the principles of preparation for innovative activities, explains the importance and role of these principles in the development of the student's personality. Also, the directions of the organization of spiritual and educational activities in higher education institutions were analyzed, conclusions and recommendations were given.*

**KEYWORDS:** *Spiritual –Enlightenment Personality, Individual, Principle, Development, Homeland, Democratic Society, Intellectual Ingenuity, Celebrations, Theories, Directions, Values, Cooperation.*

### INTRODUCTION

It is no secret that the most important component of building a civil society in Uzbekistan is to work continuously in the field of spirituality and enlightenment, the continuous development of the individual. These issues must become the basis and condition of the development of society, as well as a unified system. At the heart of this system should be immortal values such as spirituality, morality, enlightenment.

The principle of humanization and democratization of education, the development of creative activity and independence of students, teachers and educators serve as a guide to ensure their cooperation in the implementation of various socially useful activities.

Creative activity in students, intellectual ingenuity, moral competence, the formation of a scientific worldview, in order to form their active participation in a wide range of socially useful activities, there is a special place for spiritual and educational activities in higher education institutions.

Therefore, in this article we think about the principles and forms of spiritual and educational activity in educational institutions, its planning, organization.

Love for one's homeland and humanistic feelings are the eternal characteristics of our people. The preservation and further development of these unique human qualities and the upbringing of our children as worthy sons and daughters of a free and democratic Uzbekistan should be the main focus of our work in the field of spirituality. Therefore, it requires a clear planning of spiritual and educational activities in educational institutions, the creation of a system of spiritual and educational education, the focus of its forms and methods on the formation of the spiritual and educational worldview of the younger generation. Any set of upbringing, measures, and spiritual-enlightenment activities is purposeful only if certain rules and requirements are followed, or if destiny is based on them. These rules, requirements, and principles are referred to as "principles" in pedagogical science.

In fact, spiritual and enlightenment activity also follows certain principles. Principles of spiritual and educational activity – this is the direction of educational activities organized in educational institutions for the purpose of educating a mature generation, content, methods and organizational forms, the rules that determine the observance of the basic requirements for the interaction of participants in the educational process.

The principles of spiritual and enlightenment activity are a set of rules, requirements and guidelines for teachers and educators. It is determined by the tasks of educating a mature person and reflects its laws, based on the teachings of universal education, as well as scientific and pedagogical achievements. Therefore, adherence to these principles in the process of spiritual and enlightenment activities increases its effectiveness, develops quality indicators.

Based on the theories of modern world and national pedagogy, the principles of spiritual and enlightenment activity can be grouped as follows:

- ✓ The principle of social orientation of spiritual and enlightenment activities;
- ✓ the principle of voluntariness, independence, play and romance;
- ✓ the principle of approach to work in terms of creativity, initiative, the pursuit of innovation;
- ✓ the principle of planning spiritual and enlightenment activities and ensuring that the activities are in line with the strength of students;
- ✓ the principle of regularity, duration, continuity and effectiveness of spiritual and enlightenment activities;
- ✓ the principle of taking into account the age and individual characteristics of students in the organization of spiritual and enlightenment activities.

Let us now turn to the description of these principles of spiritual and enlightenment activity:

### **1. The principle of social orientation of spiritual and enlightenment activities.**

This principle is based on social development in the organization and implementation of spiritual and enlightenment activities, based on the ideological and political, socio-economic and spiritual and cultural development of the country, the content of extracurricular activities, the activities of clubs, associations, the development of the country, as well as based on the achievements of science, technology, culture and art.

**2. The principle of voluntary participation in spiritual and enlightenment activities.**

This principle applies to the spiritual and enlightenment activities organized in educational institutions, such as facultative, clubs, various sections, clubs, etc. selection based on the interests, desires, and abilities of the students participating in the program, and in doing so, to ensure that they are voluntary. The principle of voluntariness also implies that there should be no more than two extracurricular activities organized in educational institutions in order not to overwhelm and strain students, taking into account their voluntariness.

**3. The principle of taking into account the independence, initiative, creativity of students and youth in spiritual and enlightenment activities.**

This principle implies the need to organize spiritual and enlightenment work based on the interests and initiatives of students. Any event, first of all, should be based on the independence of students, the teacher-educator should inspire them, develop their activities. Then students develop initiative, interests, and creative abilities. They learn to perform any event independently, with high interest and initiative. They develop a sense of self-control.

**4. The principle of being in the form of play activities, romance of educational activities.**

It is advisable to apply this principle mainly to small and high school students. Because young and middle school age students are mostly more in need of play activities. However, the spiritual and enlightenment activities organized in these educational institutions are focused on the rules that reflect the basic requirements for the direction, content, methods, organizational forms of education, the interaction of participants in the educational process.

**5. The principle of taking into accounts the age and individual characteristics of students in spiritual and enlightenment activities.**

According to this principle, the tasks and content of the activities should be appropriate to the age and level of preparation of students, and should not negatively affect their health, spiritual and moral potential, worldview, intellectual intelligence.

Based on the above-mentioned principles of spiritual and enlightenment activities, attention is paid to their integrity, interaction, complementarities, if used effectively, they will ensure that students' educational, pedagogical and developmental activities are targeted, and that a mature person becomes a full-fledged person.

Purposeful organization and direction of spiritual and enlightenment activity is the definition of its content with a clear definition and development. If a content and plan imbalance is established, the intended goal will not be achieved. Accordingly, man is brought up incorrectly; from which society, people, and man himself suffer. This means clearly defining the content and planning it properly. Otherwise, as the great thinker Bedil said, if the architect does not lay the first brick correctly, the wall will remain crooked even if it hits the stars. This idea of Bedil is related to spiritual – enlightenment activity. Therefore, it is necessary to have a clear idea of the content of spiritual and enlightenment activities, to correctly define and plan its directions.

Spiritual and enlightenment activity is the essence of man as a socio-cultural being, which enriches his inner world, which encourages him to spiritual purification and ascension and also it is important to know and propagate universal values that strengthen the conscience, faith, beliefs, worldview, ideological potential, or the process of building and developing the intellectual

intelligence and spiritual and moral potential of a particular society in accordance with its goals and objectives. Accordingly, in the development of society, socio-political, economic and cultural activities, it is necessary to determine and plan the content of spiritual and enlightenment activities in higher education in the following areas.

- I. Organizational and educational work.
- II. Ideological (ideological-political) education to strengthen students' social activity and attitude to learning.
- III. Forming the foundations of the scientific worldview, deepening and expanding knowledge, increasing cognitive activity.
- IV. Fostering a culture of universal, national morality and behavior.
- V. Beauty, sophistication and artistic education.
- VI. Fostering diligence and love for the working people.
- VII. Economic and environmental education and nature protection.
- VIII. Improving the legal knowledge of young people.
- IX. Caring for wellness and physical fitness of students.
- X. Spiritual and enlightenment and also, ideological works carried out with teachers and educators and workers of higher educational institutions.
- XI. Working with parents and the neighborhood.
- XII. Spiritual and enlightenment work with public organizations in higher educational institutions (Youth Union, Trade Union and Women's Committee).

As mentioned above, in the process of teaching all subjects in higher education institutions should be focused on improving the spiritual and educational culture of students and extracurricular activities. At the same time, each student should understand the essence of the concepts of "spirituality", "culture", be aware of the sources of our national spirituality, they must have the skills to learn freely from these sources. In our opinion, it is expedient to cover the areas of spiritual and educational activities organized in higher education institutions as follows:

### **1. direction:**

To celebrate Independence Day, Knowledge Day, Anniversaries, Teachers' and Coaches' Day, Constitution Day, Defender of the Fatherland Day, religious holidays (Ramadan and Eid al-Adha), Harvest Day, Navruz, Remembrance and Respect Day, and it is also planned to organize excursions to historical monuments, shrines of the republic, competitions such as the coach of the year.

### **2. direction:**

Ideological education, study of information on domestic and foreign policy of the country, taking into account the age and individual characteristics of students, to study the works of our President, to get acquainted with the decisions and information of the Upper House, issues such as studying the essence of the symbols of our state, getting acquainted with the activities of statesmen will be discussed.

**3. direction:**

The foundations of a scientific worldview are cultivating the culture of intellectual labor, cognitive activity and a conscious attitude to learning. Making conversations, discussions, scientific-practical conferences about “Learn to Read”, “My Fun Hobbies”, “My Interests”, “Human and Technical World”, “From the Lives of Celebrities”, “My Dreams and Interests”, “The World I Know and Don't Know”, “For Science”, and besides that playing games like that “Think, seek, find”, “Cheerful and clever” and etc.

**4. direction:**

The issues of education in Islam, which form the basis of universal morality, the study of the teachings of our scholars, organizing roundtables on topics such as “Ethics Lessons”, “Spirituality and Life”, “Life and Etiquette”, debates on “Girls' Chastity”, “Pride of Youth”, “Women's Culture”, and conversations, dressing, conversations on manners, parties, conferences.

**5. direction:**

In order to develop the aesthetic culture of students and faculty, to provide information about well-known artists, to organize meetings, interview on “Music is my life”, “Words touch the heart, clothes touch the beauty”, the production of stands with the names like that “In the world - my world - Bukhara Sharif”, “Why I love Uzbekistan”, meetings with artists, poets, writers, composers, actors, directors, organization of readers' conferences; organization of art circles, excursions, competitions on the beauty of etiquette, moral culture, taste and rules of conduct.

**6. direction:**

Holding meetings with labor leaders, heroes, veterans; socially useful labor Saturdays, participation in Sundays; participation in technical creative circles, clubs, and repair and construction teams; the production of stands “Appreciate work”, “Profession and labor”, “My profession is my pride”; professions, showcases of labor heroes, photomontage “Our city in the years of independence” and etc.

**7. direction:**

Economic education and nature protection; economic knowledge, information about savings; conducting conversations about the maintenance of classroom equipment, textbooks, manuals; organization of stands “Economy and Education”, “Water and Life”; meetings with economists, accountants, bank employees, organization of question and answer evenings.

**8. direction:**

On raising legal awareness of students: fostering high civic qualities in students, fostering respect for the Constitution and laws of the independent Republic; formation of loyalty to the ideas of national independence, intolerance of religious extremism and fundamentalism; organization of conversations, meetings, question-and-answer evenings with people's deputies, law enforcement officers; organization of exhibition stands “Take care of your own home”, “Police is my guardian”, “Legal awareness - the need of the hour”; Rules of the road, the organization of the circle “Young Lawyer”; “Do you know the law?” conduct a review competition.



**9. direction:**

Health and care for the physical fitness of students. Organization of morning health classes in educational institutions: physical education and physical culture classes, improving the activities of clubs. Strengthening the focus on strengthening the student movement organs: organization of sports sections; development of schedules of sports games, competitions for the academic year; regular sports games, such as the "Little Universidad", "Olympic Reserve", the promotion of a healthy lifestyle and its active implementation; the contest "Healthy body, healthy mind".

**10. direction:**

Spiritual and enlightenment activities among teachers and students. Talks on "Spirituality - the flower of the nation", "Islamic torch of spirituality", "Science of Hadith - the science of life", "The pillars of our spirituality", organization of evenings, study of laws and regulations such as the Constitution of the Republic of Uzbekistan, "Labor Law", "Family Code", "Criminal Code", "Law on Education", "National Training Program", organizing evenings on "Teacher's Glory", "Educators' Skills", "Professional Culture", "Young Generation Coach".

**11. direction:**

Work with parents and the community. In order to determine the pedagogical knowledge of parents of students on the territory of the educational institution to organize contests "Knowledge of the population"; conversation on "Seven neighborhood parents for one child", organization of evenings; class, group parent meetings; Holding an "Open Day"; organizing the activities of the parents' committee; organization of seminars "Parents' Corner", "Family and Society"; organization and holding of celebrations with students, parents, watching movies, going to the theaters, meetings and evenings "Clear neighborhood", "Neighborhood- the hearth of culture", "Responsible family".

**12. direction:**

Spiritual and enlightenment activities carried out by the higher education institution with public organizations. The establishing activities in cooperation with public organizations such as the Youth Union, trade unions, women's committees, the establishment of scientific, technical, cultural, sports and physical education associations of public organizations. The establishment of pedagogical guidance on the spiritual and enlightenment work of students after classes. The above-mentioned spiritual and enlightenment work is planned for the academic year. Based on the annual plan, monthly and weekly managed works are created.

In order to carry out spiritual and enlightenment activities in the above areas, the work is organized and planned for the academic year or the beginning of the year.

Spiritual and enlightenment activities are organized in various forms. This can be roughly divided into three groups:

1. Individual work.
2. Circle work.
3. Public works.

Individual spiritual and enlightenment activities include Olympiads, competitions with talented students, competitions, exhibitions. Although this type of event is attended by many people, we

call it a one-of-a-kind spiritual and enlightenment activity, because each participant participates individually, defends the school, the region individually for a particular type of event. Science Olympiads are the most important means of developing an interest in knowledge. Its educational value is that, although it is conducted on a particular subject, the individual tasks, questions created in it serve to develop the student's creative thinking, strengthen the desire to learn.

The type of individual spiritual and enlightenment activity in the form of competitions and exhibitions also develops students' creativity and purposefulness. For example, the student participates in competitions and exhibitions such as "Skillful hands", "Technical creativity", "Poetry space", each of which demonstrates their creativity, ability and talent. These competitions, starting from the higher education institution and being held throughout the country, cultivate in students a sense of responsibility, pride and struggle for honor.

The most common form of spiritual and enlightenment activity in educational institutions today is the work of the circle. Clubs and clubs in higher education, such as science clubs, amateur art, photography, radio, amateur film clubs, "Young Literary Scholar", "Young Reader", "Young Teacher" also have great educational value.

Participation in clubs and clubs not only develops students' cognitive abilities, creative thinking, but also strengthens their responsibility to the country, the motherland and the people, and therefore serves to increase the spiritual and educational potential of the younger generation.

Another form of spiritual and enlightenment activity is mass events. These include mornings, theme nights, debates, question and answer nights, conferences, festivals, sports festivals and games, excursions, and more.

Thus, the spiritual-enlightenment activity is comprehensive. Indeed, spirituality and enlightenment are the highest value. It reflects the traditions of our people, the rich teachings of our thinkers, the way of life of our historical national heroes, the hard life of those who fought for independence and freedom. That is why it is a high value. It accomplishes a great goal, such as educating a perfect man in its direction.

The above-mentioned ideas, if we carry out the work, will lay the foundation stone for the formation of a harmoniously developed generation, where spiritual and enlightenment activities will be useful. For this, it is necessary to constantly search and act. They should make the most of the existing opportunities in the field of spiritual and enlightenment activities.

Thus, the spiritual and enlightenment activities organized in educational institutions increase the thirst for knowledge of students, develop their intellectual potential and intelligence, as well as create the basis for their spiritual development.

#### **LIST OF REFERENCES:**

1. Mirziyoev Sh.M. The work of a nation with a great intention will also be great, its life will be bright and its future will be prosperous. - Tashkent: NMIU "Uzbekistan", 2019. - 400 p.
2. Law of the Republic of Uzbekistan "On Education", - Tashkent, 1997.
3. "National training program". - Tashkent, 1997.
4. Pedagogy // study guide. Edited by A. Munavvarov - Tashkent, "Teacher", 1996.
5. Formation of student spirituality "Shark", 2000.

6. Umarov B, Olimov Sh. Fundamentals of spiritual and enlightenment education in higher education institutions. - T: "Science", 2004.

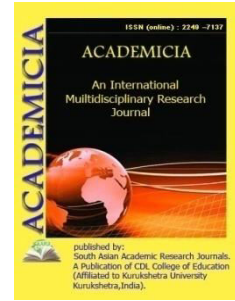

DOI: **10.5958/2249-7137.2021.01931.5**

## ATHLETES' PERFORMANCE WITH YOGA AND ASSOCIATED EXERCISES

**Dr. Anjana Lohan\***

\*Associate Professor,  
Head, Deptt. of Physical Education, S.D. Mahila Mahavidyalay,  
Narwana Jind, INDIA

### ABSTRACT

*Yoga offers many mental and physical advantages to athletes. It may also assist in reducing tension, promoting relaxation, and promoting restful sleep. Athletes who are prone to overexertion may benefit from these features. Yoga provides many advantages to athletes, including improved flexibility and mental toughness. Here you'll find out more about yoga's benefits for athletes, how to create a regimen, and why you should work with a yoga expert. Benefits As your flexibility, balance, and coordination improve as a result of yoga, you'll be more productive. There's a tonne of evidence to back up the effectiveness of yoga for athletes. Check out some of the most recent findings in this area of study. According to a short research conducted in 2016 According to a reliable source, 26 male college players' performance improved after practising yoga. When compared to the 12 athletes who did not practise yoga, the 14 who did it twice a week improved their balance and flexibility significantly. In sports requiring balance and flexibility, yoga may help you perform better. Through awareness of your body, breath, and the present moment, yoga may help you build mindfulness. This may help you focus more during physical exercise.*

**KEYWORDS:** *Athletes Performance, Sports in India, Yoga in Sports*

### INTRODUCTION

Sports offer many opportunities for quick thinking, which yoga helps you develop. It's possible that all of your planning and forecasts have gone awry, and you'll have to start over again. You'll need a clean mind to make decisions like these. Yoga's focus on breathing and posture helps people think more clearly and objectively.

Many sports require exertion, which yoga helps you do without sacrificing flexibility. The amount of oxygen that enters your body determines your stamina, which is a result of your breathing process. With the use of pranayamas, you may learn to regulate your breathing. When you're swimming underwater or sprinting toward the finish line of a marathon, this gadget comes in useful.

### **Yoga's advantages for athletes**

Yoga helps you become in shape because it tightens and stretches your muscles, which makes it easier to exercise. Yoga also aids with weight reduction, allowing you to move more quickly.

When you do yoga, you develop more than simply your speed and reflexes; yoga connects your inner and outward selves. Yoga's primary purpose in athletics is to bring the mind, body, and spirit together. As a result, your concentration and accuracy are improved.

An independent study showed that those who regularly meditated had higher levels of awareness. Shooting and dart throwing improved as a result, showing that repetition is an effective way to improve ability in high-precision sports. To completely grasp the advantages of yoga, further study into other sports is required. To help athletes avoid injury and overexertion, yoga provides many advantages.

### **Soccer**

A 2020 research of 31 male soccer players found that those who participated in a 10-week yoga programme had reductions in tiredness, pain, and the risk of injury. However, 10 weeks after the program's conclusion, the participants reported feeling worse about themselves. This may be a short-term consequence of increasing distress awareness, leading to an impression that distress is occurring more often. To go farther with these results, further in-depth research is required.

### **A Sport Such As Field Hockey**

Hot yoga was tested on 10 top female field hockey players in a recent short research as an alternate heat stress method. Performing hot yoga while exercising improves cardiovascular health and the body's ability to control its internal temperature, according to the study team.

The best regimen to adopt is one that involves the following:

It's better to practise yoga every day for a short period of time rather than once or twice a week for an extended period of time. If you're active in activities that need a lot of stamina, try to balance that off with a moderate kind of yoga.



Figure 1 : Athletes on Yoga Exercises

The following are some of the many advantages of yoga for athletes of all levels: With all of its positions and postures, soccer player yoga strengthens the core. For basketball players, yoga improves memory and concentration, making it a must-have for students who want to do well in school. Hockey players benefit from yoga because it enhances their flexibility and widens their range of movement. Yoga is an excellent method for cricketers to enhance their overall body balance. There are many health advantages of yoga for baseball players, including cross-training, as well as baseball-specific ones. Additionally, yoga's advantages for athletes include improved body mechanics for everyone who does it. Football players' proprioception improves with yoga, according to research. Cricketers benefit greatly from yoga since it improves posture, power, strength, and speed. Yoga for athletes is also known to reduce power leakage in cleans and improve efficiency with all explosive body movements by aligning the body optimally. Football players' yoga develops all of their muscles tremendously.

Yoga for athletes improves lung capacity and breathing patterns by increasing lung capacity and decreasing breathing patterns. With frequent practise, it may help those with asthma and other respiratory problems. Biking and yoga, in particular, may help a person stay healthy while also increasing their competitive spirit, allowing them to advance more steadily in all of their athletic endeavours. Athletes may benefit greatly from yoga and gymnastics since they help with rehabilitation. It improves lymphatic flow, which in turn helps the muscles digest metabolic waste more quickly. This hastens the healing process while also promoting regrowth. Football players benefit from yoga because it helps them concentrate and clear their minds. Running and yoga both assist to boost the immune system and bring the body's hormones back into balance. Athletes, however, need this in a crucial manner. Footballers' yoga reduces stress and detoxifies the body, making it easier to cope with frustration. It makes it possible for the muscles to be stretched and for the blood to be filled with oxygen.





Figure 2 : Adoption of Yoga Exercises for Strength

The body is more prone to damage when it's out of whack. When you hold or move your body in a different way to make up for tightness or stiffness, you put yourself at risk of injury.

Yoga aids in the re-alignment of the body and the correction of imbalances before they develop into ailments. In only a few months of working with the football squad, the trainers and coaches saw a reduction in injuries compared to prior years. On the field, it was clear that the athletes were taking better care of their bodies because of it.

Poses that relax and stretch your muscles and tissues should be part of your daily practise. Flexible, mobile and range of motion are improved. Yoga styles like yin, restorative, or Hatha may also be included in this category.

Yin yoga aids in the reduction of stress and the expansion of your range of motion. It's perfect for individuals who are suffering from tightness or discomfort. Yin yoga may assist athletes deal with the stress that comes with their sport.

By reducing tension and discomfort, restorative yoga promotes relaxation. Hatha yoga moves at a more leisurely pace, although postures may be challenging.

To get you started, here are a few postures to try:

#### Downward-Facing Dog

This posture, which is appropriate for practitioners of any skill level, helps to align the body and rectify imbalances. It helps loosen up tight glutes, hamstrings, and calves by reducing discomfort and stiffness. It also helps loosen up your neck, shoulders, and back.

Raise your hips to the ceiling while keeping your hands pressed against the tabletop.

2. Extend your spine by widening your shoulders.
3. Align your chin with your chest or tuck your chin into your upper arms so that your brows meet.
4. Keep your knees slightly bent to enable your spine to extend.

5. Remain in this posture for one minute at the most.

Relax your spine, increase your flexibility, and enhance your circulation with this easy backbend. Turn your eyes upwards and allow your head to sink back to deepen the posture and activate your throat chakra.

Lie on your stomach, with your knees bent and feet flat on the floor. To do this pose, you'll lay your hands exactly beneath your shoulders on the floor. Bring your elbows in toward your midsection. You may do this by lifting your chin, chest, and shoulders half-way or all the way up. Maintain a little bend in your elbows while broadening your chest. Use your hamstrings, low back, and abs. Remain in this posture for 45 seconds or more. Perform this step one to three times.

Pose with the Legs Up the Wall. This restorative posture is great for recharging your batteries while also improving your circulation and relaxing your muscles. A pillow or blanket folded in half may be placed under your chin or hips if you want. Place your right leg on the wall and sit with your right side facing the wall. Swing your legs up against the wall as you lie back on your back. As close to the wall as possible with your hips. Depending on your preference, you may either place your hands beside your body or above. This posture should be held for at least 20 minutes.

### **Consultation to Expert in Yoga**

Consult a yoga expert if you'd want to enhance your skills or deepen your practise. Find a teacher whose philosophy aligns with your own. These objectives don't have to do with yoga or your particular activity. Many yoga instructors have worked with athletes in the past. With their help, you may create a programme that will improve your athletic ability while also reducing your risk of injury.

They may assist you in determining which poses are most beneficial to you, as well as aid in the recovery process if an injury has occurred. They may also verify that your form and technique are proper.

Ultimately, to improve strength, flexibility, and balance, consider yoga, which offers a slew of advantages for athletes. In turn, this may help you move more freely, move more quickly and better coordinate your movements to enhance your performance and keep you safe.

You will come up against this scenario as a sports player at some point in your career. Each time, the stakes and the task will likely be different. In spite of everything, the objective is always the same: to put on an outstanding show despite all the obstacles. It would be the cherry on top if we could do this while remaining calm and collected. It's a daunting task no matter where you are in your athletic career, and that's where yoga comes in.

Sports players' training regimens have become incomplete without the use of yoga. Athletes, swimmers, tennis players, and ballplayers all benefit from yoga's function in sports. If you're not sure why, read on to learn about the many advantages that yoga offers for athletes.

The kind of sport necessitates a lot of abrupt twisting and turning by the participants. Even uncomfortably may occur from time to time. Taking too many risks raises the likelihood of making a mistake. To the rescue, we turn to yoga!

## CONCLUSION

Yoga teaches you how to maintain your equilibrium, be calm, and have self-control. It gets your body in shape so you can do these exercises. It teaches you to be calm and patient as well. Yoga poses help loosen up tense muscles, reducing the risk of injury. It opens the hips, back, and chest, among other body regions, as it stretches and strengthens them. Stretching and bending your body in various ways reduces the risk of injury from things like muscle tears and sprains. As a result of your yoga practise, you heal faster. It's not enough to just sleep and relax after a long and arduous physical exercise. Yoga aids in the efficient and pleasant relaxation of your weary body and mind. This is due to the methodical and elegant nature of asana practise. As a result, you'll feel less stressed and be more likely to recuperate quickly. Asanas like vrikshasana (tree pose) and virabhadrasana (warrior posture) assist improve your feeling of balance. Both physically and psychologically, you'll want to maintain your composure and equilibrium. Along with helping you stay flexible, yoga helps you stay strong in other sports like gymnastics, shooting, and archery. When you do yoga, your mental determination is strengthened, and the negative mental chatter is silenced. You're certain that your mental power will allow you to transcend your physical limitations. When it comes to sports, it's important to remember that it's not only about becoming fit. To succeed, you'll have to win a mental war. When you're stressed out, yoga may help you stay calm and collected.

## REFERENCES

1. Philipp Maas (2013), A Concise Historiography of Classical Yoga Philosophy, in Periodization and Historiography of Indian Philosophy (Editor: Eli Franco), Sammlung de Nobili, Institut für Südasien-, Tibet- und Buddhismuskunde der Universität Wien, ISBN 978-3-900271-43-5, pages 53–90, OCLC 858797956
2. Satish Chandra (2007), Historiography, Religion, and State in Medieval India, ISBN 978-8124100356, pages 135–136
3. Ernst, C.W. (2005). "Situating Sufism and Yoga" (PDF). *Journal of the Royal Asiatic Society*. 15: 15–43. doi:10.1017/S1356186304004675. S2CID 53485495.
4. "Situating Sufism and Yoga" (PDF). 5 September 2010.
5. Carl W. Ernst, Persecution and Circumspection in Shattari Sufism, in *Islamic Mysticism Contested: Thirteen Centuries of Debate and Conflict* (Editors: Fred De Jong and Berndt Radtke), Brill, 1999
6. "Sidang Media – Fatwa Yoga". Islam.gov.my. Archived from the original on 6 January 2009. Retrieved 5 September 2010. The Fatwas of Religious Council in Islamic affairs on Yoga. After carefully studied various reports and factual data, the Council unanimously agreed that this ancient India religious teachings, which involves physical and mental exercises, are Hinduism in nature known as wahdat al-wujud philosophy (oneness of existence; the realization of identity between the Self in man, Atman; and the Divine, BRAHMAN: 'Brahman is all, and Atman is Brahman'). It is prohibited (haram) for Muslims to practice it.
7. Top Islamic body: Yoga is not for Muslims – NBC News
8. "Mixed reactions to yoga ban". Thestar.com.my. 23 November 2008. Archived from the original on 22 June 2011. 5 September 2010.

9. Paul Babie and Neville Rochow (2012), Freedom of Religion Under Bills of Rights, University of Adelaide Press, ISBN 978-0-9871718-0-1, page 98
10. "Badawi: Yoga for Muslims OK without chant". Saudi Gazette. Archived from the original on 31 July 2013.
11. "Indonesian clerics issue yoga ban". BBC News. 25 January 2009. 6 April 2010.



**ACADEMICIA**  
**An International**  
**Multidisciplinary**  
**Research Journal**  
 (Double Blind Refereed & Peer Reviewed Journal)

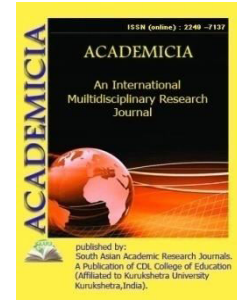

**DOI: 10.5958/2249-7137.2021.01932.7**

## IN THE NETWORK OF ROADS APPLICATION OF THE INTELLIGENT TRANSPORT SYSTEM

**Ashurov Elyor Tulkinovich\* ; Sharipov Bokhodir Kholboevich\*\***

<sup>1,2</sup>Senior lecturer at Termez State University,  
 UZBEKISTAN

### ABSTRACT

*This article provides an overview of the development of the transport network in the use of roads, the expediency of the use of intelligent transport systems in the construction of road infrastructure and the optimization and management of traffic. It is expedient to use science-based methodology to increase the transport supply of the settlements of the region, the optimal distribution of freight flows in the transport networks and the development of the transport network. The governments of foreign countries have found it necessary to use an intensive [1] approach to solving the transport problem when using the road network. ITT is an important, ie efficient and safe level of increasing the traffic flow capacity of highways. It will also reduce the cost of building road infrastructure. As a result, consumers will be provided with a large amount of information and security, as well as the level of interaction of the participants will increase the quality.*

**KEYWORDS:** *Highways, Road Transport, Transport Network, Transport Network Section, Optimal, Throughput, Problem, Solution, Freight Flow, Software, Intelligent Transport Systems.*

### INTRODUCTION

The road network is considered to be the most important for the country's economy. As the infrastructure of the road network, which provides communication between each region of the region, develops, the state of the transport system that benefits from it is closely linked with the sustainable development of the national economy. Reliable and high-tech transport infrastructure will allow to meet the growing demand of society in freight and passenger transportation.

In this case, the "optimal distribution" of freight flows on the roads for each mode of transport gives only the "local optimum" for this mode of transport. The essence of the matter is to achieve a "global optimum" based on the optimal distribution of traffic to different transport networks.

Therefore, it is expedient to study the transport networks of regional highways and railways together.

Research on the development of the national road network and ensuring safe traffic is a key issue in the development of safe and low-cost transport networks that meet the requirements of road users to export their products to domestic and foreign markets.

It is more difficult to define the transport network and solve their development on the basis of unscientific basis in accordance with the conditions of the region. It is expedient to use science-based methodology to increase the transport supply of the settlements of the region, the optimal distribution of freight flows in the transport networks and the development of the transport network. Also, with the introduction of intelligent transport systems, the region will expand opportunities for the development of a multimodal transport network and efficient use of the network. In this regard, practical work is being carried out in the framework of the project "Intelligent Transport Systems: New ICT based Master's Curricula in Uzbekistan".

To address the above, experts have proposed several methods [1]:

- construction of extensive road infrastructure;
- Intensive use of ITS in optimization and management of traffic flow.

According to many authors on the construction of extensive road infrastructure [2], such infrastructure for the development of the transport services market at the present stage is a multimodal transport network, taking into account international transport corridors.

Multimodal transport is domestic transport with at least two modes of transport in the road network [3].

The main characteristic of the transport system is its provision. Provision is determined by the geographical advantage of the region (district, city or corridor) over all regions [4].

It is recommended that the definition of a low-cost transport network be performed by the method of graph theory. In this case, the existing points of road and rail transport (in terms of sending, receiving, economic and technical, capacity and other indicators) are shown as nodes of the graph. Addresses where different modes of transport are connected, i.e., points where it is possible to reload from one mode of transport to another, are represented in the form of several addresses, respectively.

These methods are based on the optimization of freight flows of vehicles in the road network [5,6], which simultaneously addresses the issues of optimizing freight flows in the network and the development of the transport network.

In the process of solving the problem, the characteristics of the arcs connecting the settlements (nodes) in the transport network are placed on the sections, and the flow of cargo (transport) is provided through low-cost arcs. The solution to this problem is obtained using a program designed for computer technology.

The governments of foreign countries have found it necessary to use an intensive [1] approach to solving the transport problem when using the road network. ITT is an important, ie efficient and safe level of increasing the traffic flow capacity of highways. The Government of the United States is actively developing and supporting the ITT. Because unlike the standard method of



building new highways, it is a useful way to solve this problem. Research is being carried out to address this issue in the framework of a practical project on "Optimal development of the transport network in the regional road network and the widespread use of logistics principles in the effective management of future freight flows."

The use of intelligent transport systems in the optimization and management of traffic flow in the road network is based on maximizing the use of the transport network, improving the efficiency and safety of the transport process, improving the comfort of transport users and drivers and providing emergency medical care. It will also reduce the cost of building road infrastructure. As a result, consumers will be provided with a large amount of information and security, as well as the level of interaction of the participants will increase the quality. In developed countries such as the United States, Japan, Germany, France, China, 20-30 years ago, these technologies were widely used in traffic management.

The introduction of intelligent transport will make it possible to comprehensively improve the socio-economic interests at several levels, including its advantages [8]:

- Save time on the road, reduce the labor force of drivers and traffic congestion;
- environmental protection is provided; □
- Reduced the cost of road infrastructure construction; □
- The development of industry will provide employment for most workers.

Intelligent transportation system (ITT) is a complex engineering structure that is an innovative approach to modeling transport systems and traffic flow management.

Currently, research is being conducted in 6 higher education institutions of the country on "Intelligent Transport Systems:".

Taking into account the above, the widespread introduction of intelligent transport systems in the road network in this area will allow to fully use the opportunities and resources of the country's potential to increase exports and transit of road transport services and minimize and target the cost of construction of transport networks.

#### REFERENCES:

1. Merenkov AO Foreign experience in the implementation of intelligent transport systems / University Bulletin No. 7.-2015. <https://cyberleninka.ru/article/n/zarubezhnyy-opyt-v-oblasti-realizatsii-intellektualnyh-transportnyh-sistem>
2. N. Nesterova, S. Goncharuk, V. Anisimov, A. Anisimov, V. Shvartcfel, Set-theoretic Model of Strategies of Development for Objects of Multimodal Transport Network. <https://doi.org/10.1016/j.proeng.2016.11.892>.
3. Butaev Sh.A., Sidiknazarov KM, Murodov AS, Kuziev AG Logistics (flow management in the supply chain) .- Tashkent: Extremum-Press, 2012.-577 p.
4. I. Kabashkin, Modelling of Regional Transit Multimodal Transport Accessibility with Petri Net Simulation// Procedia Computer Science 77 (2015) 151 – 157. <https://pdf.sciencedirectassets.com/>

5. Zhukov V.I., Kopylov S.V. Substantiation of the mathematical model for the design of the local road network in the conditions of the Republic of Sakha (Yakutia) // Fundamental Research, 2015. No. 3.-63-67; URL: <http://www.fundamental-research.ru/ru/article/view?id=37085> (date accessed: 09/10/2018).
6. Kovshov GN, Zenkin AA Russian transport infrastructure of international importance and possible ways of its development // BTI.-M.: 1998.-issue. 40-S.56-61.



**ACADEMICIA**  
**An International  
 Multidisciplinary  
 Research Journal**  
 (Double Blind Refereed & Peer Reviewed Journal)

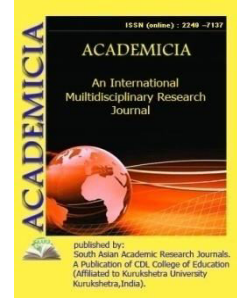

**DOI: 10.5958/2249-7137.2021.01933.9**

## STRUCTURAL TYPES OF UZBEK LANGUAGE HEMERONYMS

**Sapayeva Boljon Kadamovna\***

\*Senior Lecturer  
 Urgench State University,  
 UZBEKISTAN

### ABSTRACT

*In this article, it is given the study of hemeronyms in Uzbek linguistics and the issues of structural types of Uzbek hemeronyms are covered. The title also plays an important role in making newspaper and magazine articles meaningful, educational, and effective. It is clear that newspaper titles perform various functions such as naming, informing, appealing, linking, influencing, and advertising. The newspaper is the core of the three social structures in society that include journalism, which is the fourth largest authority after the legislature, the executive, and the judiciary. The content expressed by them is an important stylistic tool, the connotative meaning, that is, the additional expressive meaning. It is possible to achieve a general and concise expression of the meaning by dropping the suffix of the suffix in the compound participle, while maintaining the conciseness of the suffix.*

**KEYWORDS:** *Hemeronym, Media, Newspaper, Magazine, Word-Hemeronym, Compound-Hemeronym, Rumor-Hemeronym.*

### INTRODUCTION

A newspaper is a type of mass media that can show the current socio-political, economic-industrial and cultural-spiritual life of a society. Its main tasks are to provide information about the current life of the readers, to be aware of what is happening in the society. The newspaper covers all spheres of public life and reflects the history of this day in all its details. Newspapers give information the readers about the world, raise their consciousness, nourish them spiritually, direct and activates their social activities. The newspaper is a product of universal culture and an important factor in its development. The newspaper is the core of the three social structures in society that include journalism, which is the fourth largest authority after the legislature, the executive, and the judiciary. The newspaper is widely used by various classes and parties in a

society to produce current interests and views and communicate them to the public and to fight against opposition groups.

In recent years, it is no coincidence that the state pays special attention to the media, freedom of speech, freedom of the press, as a result most of the republican, regional, district and city newspapers and magazines are active. Newspaper and magazine titles were freed from ideological views, personal attitudes and inclinations, as well as various other negative attitudes.

In the resolution of the President of the Republic of Uzbekistan "On additional measures to ensure the independence of the media and the development of information services of government agencies and organizations" it is showed an analysis of the current state of the media that the challenges in the media space are not being responded to quickly and appropriately, as a result the public's need for timely and comprehensive information on large-scale reforms in the country will significantly increase the work in the field of information, information services of government agencies and organizations, qualitatively new activities of the media to require bringing to the stage<sup>1</sup>. It also includes the problem of linguistically studying the names of media outlets. Because the names indicate the subject matter of a particular publication, what type of reader audience it is intended for, and also serve an aesthetic function.

Great importance is paid to the name of media publications. The success of the media and to become a brand in many ways in the future depends on the name chosen for it. The names of the media are almost unexplored in Uzbek linguistics research.

In the dictionary of N.V Podolskaya the term hemeronym means hemero meaning "day", onym (onuma) - "name" which provide information on understanding the names of media publications<sup>2</sup>. In her research, I.V Kryukova notes that media publications are a type of media and radio, television, video and newsreels are also studied under the term hemeronym<sup>3</sup>.

The title also plays an important role in making newspaper and magazine articles meaningful, educational, and effective. It is clear that newspaper titles perform various functions such as naming, informing, appealing, linking, influencing, and advertising. The word plays an important role in revealing these features of the name. The use of the word as a singular noun depends on the characteristics of the newspaper. The information in the newspaper should be extremely concise, but meaningful and effective.

The word has a wide range of possibilities to express the information expressed in the newspaper material in a concise and fast-acting way, as well as the nominative function of the language. One word also provides emotionality and expressiveness. Advertising, which is important for a newspaper, can also be expressed in a single word.

Newspaper headlines often include one-word headlines. However, we did not find newspaper names consisting of a single word represented by other word groups (e.g., adjective, number, pronoun, adverb and verb). In the names of newspapers, especially, there are many names for one word represented by noun. Hemeronyms in the form of words are usually used in the general consonant of a noun. There are some example: "Ma'rifat", "Sadaf", "Ishonch", "Jamiyat", "Adolat", "Sport", "Bekajon", "Tafakkur", "Darakchi", "Sogdiyona", "Muhofaza", "Humo" and "Erkatoy". Verbal hemeronyms can sometimes be used in a variety of grammatical forms, with the addition of a definite consonant other than the main consonant.

Hemeronyms in the form of a definite consonant usually appear as a specific part of speech. In this case, the suffix not only indicates the syntactic function of the hemeronym in the text, but also expresses the word as a grammatically formed unit, specifying its meaning.

We only came across the word agreement in the name of the "Post". Depending on the structure of the phrase, it consists of simple - two independent words and complex - of three or more independent words. Thus, the number of independent words in a speech unit is the basis for dividing phrases into simple and complex combinations<sup>4</sup>.

Hemeronyms in the form of word combinations are used more and more actively than in the form of word hemeronyms. This is explained by the need to inform the reader as much as possible about the newspaper. Because a phrase is, in essence, a form of expression in the units of speech of the various relations between events and concepts. The semantic-grammatical relationships that describe a combination of words also indicate the relationship between the meanings of the parts of speech (concepts, words, events). The meaning of a phrase is usually richer and clearer than that of a single word. Words are used to create phrases, and phrases are used to create sentences.

Compound hemeronyms are used in various forms in newspaper titles. Flexible compound-hemeronyms. As you know, in the syntax of the Uzbek language, the adaptive relationship is seen in the context of the relationship between the present and the future. In this case, there is a correspondence between the subject and the subject, and with the change of one of the two words, the subordinate clause changes to the corresponding form. Newspaper titles - we can also find a lot of names that are combined in hymeronyms.

From our observations, it is clear that among the word combinations in newspapers, the compound hemeronyms have a special place. These types of hemeronyms are distinguished by their conformity to the nature of the newspaper. The content expressed by them is an important stylistic tool, the connotative meaning, that is, the additional expressive meaning. It is possible to achieve a general and concise expression of the meaning by dropping the suffix of the suffix in the compound participle, while maintaining the conciseness of the suffix. Most importantly, in both cases the meaning can be expressed clearly, concisely, fluently and meaningfully. The names of such newspapers and magazines as "Xalq so'zi", "O'zbekiston ovozi", "Islom nuri", "Qishloq ko'chalari", "Ko'ngil ko'chalari", "Yoshlar ovozi", "O'zbekiston futboli", "Kitob dunyosi", "Bolalar sporti", "Adolat yog'dusi", "Istiqlol umidlari", "O'zbekiston bunyodkori", "Istiqlol odimlari", "O'zbekiston matbuoti", "Salomatlik sirlari", "Murabbiy mahorati" show that the future tense is often used in an indefinite form. Its use in this form is newspaper-friendly, and also serves to ensure compactness.

Adhesive compound-hemeronyms. Hemeronyms are also widely used in the names of newspapers and magazines. In this respect, they lag behind the compounds in the adaptive relationship. Hemeronyms can be used in different forms. The names of newspapers and magazines, such as "Kafiyat", "Jannat Makon", and "Jajji Akademik", are hemeronyms that are joined together.

It is well known that in a managerial relationship, a word in a noun or noun function is related to a verb or adjective, and comes in a certain grammatical form depending on the demand of the dominant word.

This connection occurs both semantically and grammatically. In a managerial relationship, the subordinate component comes with a consonant affix or with an auxiliary.

The names of the journals "Korxonani boshqarish", "Maktabda biologiya", "Maktabda kimyo", "Maktabda geografiya" are examples of hemeronyms created by management.

The names of newspapers and magazines are also given in the form of sentences, which expands the possibilities of expressing the content of the text, conveying information.

Hemeronyms in the form of sentences, although small, are found in the following journals such as "Kuch –adolatda", "O'zbekiston – islom sivilizatsiyasi markazi".

Gemeronyms are grammatically diverse and have their own characteristics. This is primarily due to the fact that they are compact and concise, used in a variety of forms and shapes.

The structure of hemeronyms depends on the content of the newspaper or magazine. Consequently, the word-gemeronym, the compound-gemeronym, and the speech-gemeronym differ in their perceptual meanings. They are a specific part of speech - a communicative unit, and their structure must, of course, be based on the existing syntactic patterns in the language.

#### REFERENCES:

1. N.V. Podolskaya Dictionary of Russian onomastic terminology. M.: Nauka, 1988.S. 46.
2. I. V. Kryukova Advertising name: from invention to precedent. Volgograd: Change, 2004.- P.32.
3. Fedosova OI Linguistic status of hemeronym (on the material of Russian and British names of the media) // Izv. Volgograd. state ped. un-that. 2010. No. 5 (49). with. 76-80.
4. Охунов H. Ideonyms and problems related to their study // Current issues of linguistics. III. - Tashkent, 2006.-P.74-82.
5. Primov A., Sobirova Y. O'zbek tili gemeronimlari haqida. "Tafakku ziyosi", T.:2017, 41-43-b.
6. Kravets T. I. Newspaper titles: onomasiological and stylistic aspects, Yekaterinburg, 2002. ;
7. Kaminskaya T.L. dis. ... Dr. filol. nauk / s.-petersburg. state un-t. SPb., 2009. ;
8. Smeyukha V.V. modern types of women's press: compliance with the informational interests of the gender addressee // linguistic and philological studies. 2011. Issue. 1. Vol. 3.p. 3-10. ;
9. Fedosova OI Linguistic status of hemeronym (on the material of Russian and British names of the media) // Izv. Volgograd. state ped. un-that. 2010. No. 5 (49). with. 76-80. ;  
10.10.Rasulov R. Umumiytilshunoslik. - Toshkent, 2006, 56-57-b. Ne'matov H., Sayfullayeva R., Qurbonova M. O'zbektili struktural sintaksisiasoslari. –Toshkent, 1999, 19-b.



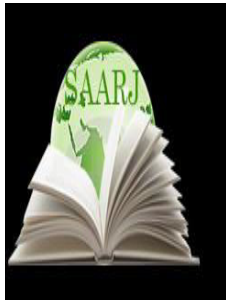

**ACADEMICIA**  
**An International  
 Multidisciplinary  
 Research Journal**  
 (Double Blind Refereed & Peer Reviewed Journal)

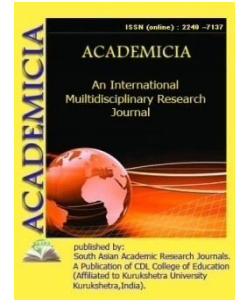

**DOI: 10.5958/2249-7137.2021.01934.0**

**TOURISM POTENTIAL OF UZBEKISTAN AND WAYS OF ITS  
 EFFECTIVE USE, DEVELOPMENT OF DIGITAL TOURISM, WORLD  
 EXPERIENCE IN TOURISM DEVELOPMENT**

**Kholikulov Ravshanbek\*; Musurmanov Islombek\*\***

\*Tour operator at the tour agency “Zamin Travel”,  
 UZBEKISTAN  
 Email id: xoliqulov@bk.ru

\*\*Manager at the hotel “Bibikhanum”,  
 UZBEKISTAN  
 Email id: islomshox1994@mail.ru

**ABSTRACT**

*Republic of Uzbekistan is a budding tourist destination offering huge potential. The country lies on the famous Silk Road and boasts a wealth of heritage sites, making it a hugely attractive prospect for the global market. This article reveals aspects of the development of digital tourism and use of world experience and makes an overview of the current status of tourism industry in Uzbekistan. The purpose of this study is to identify effective ways of tourism development in Uzbekistan.*

**KEYWORDS:** *Digital Tourism, Tourism Potential, Innovative Technology, Tourism Destination, Tourism Infrastructure*

**INTRODUCTION**

There are many opportunities and conditions in Uzbekistan for the development of this sphere. Uzbekistan, as a unique country, has the vast tourism potential of its ancient civilizations and cultures that have been developed, developed and attracted by the world's best destinations for holidays and excursions. The country's national parks and national parks are the treasures of its rich and varied nature. The centuries-old traditions of national culture, arts and crafts are carefully preserved and developed in the country. Our world-renowned national cuisine and culinary traditions are a symbol of the hospitality of the East. According to Travel Wire News (2019), Uzbekistan has great potential for an expanded tourism industry. As one of the focus areas for reform and economic expansion, tourism in the country has increased fivefold in over

the last three years. While about 1 million tourists visited Uzbekistan in 2016, the figure rose to 2.7 million in 2017, and more than 5.3 million in 2018. The number of foreign tourists is expected to rise to 7 million by 2025, and the annual foreign currency earnings from foreign visitors will reach as much as \$2 billion.

At the present stage, one of the trends in the development of the world tourism industry is the development of Internet technologies, in other words, the modern development of tourism is taking place in the digital economy. That is, the digitization process has not bypassed the tourism industry, as in many other areas.

Digital tourism is the use of digital tools in the planning, organization, control and enjoyment of travel, with a set of electronic services provided to travelers before, during and after the trip (Khurramov (2020)).

### **LITERATURE REVIEW**

In this contribution to the subject, we will focus on Uzbekistan, the country with the greatest appeal in terms of heritage due to the prominence of its cities along the Silk Road. Let us remember that the Silk Road plays a dominant role in the country's cultural, historical and architectural appeal (Kantarci, 2007a) by bringing it closer to outsiders, seeing as though the vast route used to linked up Europe, and particularly the Turkish world, with China for many centuries. In fact, the Silk Road is currently one of the products the WTO is specifically promoting, as it involves the participation of numerous Governments and will ultimately help preserve and protect a rich architectural heritage.

Uzbekistan spans 447,000 km<sup>2</sup> and was home to 30,241,000 inhabitants in 2013. It boasts the most clearly defined and prestigious tourism image of the entire region since four of its cities are included on the UNESCO World Heritage list (Samarkand, Bukhara, Khiva and Shakhrisabz), all of which lie on the ancient Silk Road route. The images and photographs of Uzbekistan included in the travel supplements of the leading western newspapers and magazines and also in the advertisements broadcast on certain global TV channels (CNN, Al Jazhira, Euronews, etc.) are nothing short of breathtaking. It can come as little surprise that this has aroused the interest of international tour operators (Kantarci, 2007a) and is doubtlessly shaping the political and economic priorities of the nation's Government in support of tourism. In this regard, Uzbekistan receives a significant contingent of foreign tourists estimated 975.000 for 2011 and 1.969.000 in 2013. It is of official statistic supported and published by the WTO, but that seem to be the result of estimates general and also express discontinuities in the series annual.

The results of our work in the country, it is worth pointing out that destination image is a fluid concept (Litvin and Mouri, 2009) because the different segments of the market appear to be affected by the individual and personal experience and by the efforts made by the destination to enhance self-satisfaction (Li et al, 2012). In this regard, it has been insisted that general travel conditions to Central Asia include barriers and decision influencers so as to shape the satisfaction of tourists with their experience (Kantarci, 2007a).

Destination image plays two important roles in behaviour: to influence destination choice in decision-making process and to condition the after-decision-making behaviours including participation (on-site experience), evaluation (satisfaction) and future behavioural intentions (intention to revisit and willingness to recommend) (Ashworth and Goodall, 1988; Mansfeld,

1992; Cooper, Fletcher, Gilbert and Wanhill, 1993; Bigne et al., 2001; Lee et al., 2005). Those destinations with strong, positive images are more likely to be considered and chosen in the travel decision process (Goodrich, 1978; Woodside and Lyonski, 1989).

Focusing on the four main hubs of Uzbek tourism, namely Samarkand, Bukhara, Khiva and the less internationally known Shakhrisabz, these can be interpreted using the two classical approaches to tourism in respect of historical centres to have risen in prominence in recent years (Chan, Milne, Fallon and Pohlmann, 1996). Thus, adopting a top-down approach to focus on these specific examples, we can discern a certain homogeneity between these cities and their scapes and scenery with other similar examples (Chan et al, 1996). The remnants of their medieval past can still be felt in these Uzbek cities, reflected in their main buildings and architecture, as can their intercultural ties (through the Silk Road), exoticism and the attributes of a secular community of inhabitants used to receiving curious visitors, pilgrims and, in a nutshell, tourists. On a different scale of things, the bottom-up approach focuses on describing the unique and attractive elements of each city (Chan, Milne, Fallon and Pohlmann, 1996). Samarkand, Bukhara and Khiva are “unique”, where demand for the cities, their perception in the eyes of tourists before arriving there and their experience once at the World Heritage Site are all studied on-site from the information gleaned from tourists, so enabling local and national authorities to improve their tourism planning.

### **Methodology**

As a core aim this research which chosen the analyzing and diversifying the actual problems of the tourism industry and proposing the ways of further development. On this direction, we monitored the latest statistics based on reports of aforementioned tourism authority of Uzbekistan- “Uzbektourism”, research groups WTTC Travel and Tourism economic impact and “Euromonitor” with the prove of authors who had made investigations on Silk Road touristic destination and its role in Central Asian states commercial deployment („Declarations| UNWTO Silk Road Programme”, 2014). As a major Silk Road tourist destination, the country possesses exotic tourist potential, distinct monuments of prehistoric times with unique natural landscapes, which may focal role to become one of the principal tourist states on the globe. That is why much attention devoted in Uzbekistan to the development of tourism and expansion of corresponding infrastructure as one of the priority directions of the nation's socio-economic development (Knobloch, 2013). Acclaimed as the paramount route in the history of humankind, the ancient Silk Road formed the first connection between the East and the West and was an important vehicle for trade between the ancient empires of China, Central and Western Asia, the Indian peninsula, and Rome. The Silk Road was more than just trade routes; it symbolized the multiple advantages arising from cultural exchange. As a result, countless historical and cultural sites persist along the network of famous paths. There are significant opportunities for destinations along the Silk Road corridors to join efforts for building transnational tourism initiatives to promote and develop shared heritage under the Silk Road brand, particularly for developing states. By taking a collaborative approach to emerging tourism for the Silk Road corridors, it is underlined that:

- sustainable approaches to destination management will be applied across the region
- Dispersal of visitation across the region will improve

- The length of stay and yield will increase
- New opportunities for investment will open up
- International relations will be strengthened
- New opportunities for public-private sector partnerships will be realized
- Touristic services will be expanded, and flow of tourist will be enlarged

As well as , by 2020 it is predicted that China, Russia, India and the Middle East's trends will increase more than 200 million tourists annually visiting (Handbook on E-marketing for Tourism Destinations, 2008) . Therefore, as one of the main Silk Road tourism destinations, Central Asian countries will be able to attract a vast amount of visitors from all over the world. As Edgar Knobloch (2013) mentioned, countries of Central Asian undoubtedly have abundant resources and potential for development of tourism. However countries need integration and modernization to become competitive in these businesses.

### **Tourism potential of Uzbekistan and ways of its effective use**

With its great historical, archeological, architectural, and natural treasures, Uzbekistan has exceptional potential for tourism. The country's diverse ecology, ranging from deserts to glaciers, mountains to steppes, gives the country great eco-tourism potential. The eco-tourism opportunities in Uzbekistan are plentiful and distinct. These include its eight state reserves (201.7 thousand hectares), three national parks (598.7 thousand hectares), biosphere reserve (68.7 thousand hectares), natural wildlife breeding center (158.9 thousand hectares), and ten natural monuments (3.7 thousand hectares) (Obidjon Khamidov, 2017).

Located on the ancient Silk Road, Uzbekistan has more than 4,000 historical and architectural sites, (Embassy of the Republic of Uzbekistan to the United Kingdom of Great Britain and Northern Ireland, 2019) a carefully saved and precious spiritual heritage, and over 7,000 historical monuments (AzerNews, 2019). These include famous ancient cities on the UNESCO World Heritage list, such as Samarkand, Bukhara, Khiva, and Shakhrisabz. Moreover, Uzbekistan is a country with strong Islamic roots. There are more than 160 historically important Muslim sites located in the country, and dozens of historical sites related to Sufism. Among these are the Mausoleum of Sheikh Zaynudin Bobo, Sheihantaur, the Mausoleum of Zangiata in Tashkent, the Bakhaudhin Ensemble in Bukhara, the Bayan-Quli Khan Mausoleum, the Saif ed-Din Bokharzi Mausoleum, and many others (Silk Road Destinations, 2019). In addition, Uzbek cuisine and wine can attract gastronomic-related tourism.

Tourism is one of the sectors Uzbekistan has sought to reform and revitalize since 2016. Its reform process aims to create jobs and new business opportunities; further the diversification and accelerated development of regions; increase incomes and living standards and quality of life, boost foreign-exchange earnings; and improve Uzbekistan's overall image and investment (AzerNews, 2019). Uzbekistan held its first International Investment Forum on November 19-21, 2018 to expand international engagement in the sector and disseminate information about the country's tourism potential.

Although Uzbekistan has made substantial efforts and launched numerous reforms to expand and improve its tourism industry as part of its program of economic growth, further actions are needed. The Uzbek government has addressed shortcomings inconveniences still connected with

border procedures, transportation, and guest accommodations. Still, some support facilities and services require action by the government or private sector; especially given the role they play in attracting tourists or encouraging them to become repeat visitors.

The Uzbekistan International Visitor Economy Survey 2014 by the World Tourism Organization, showed respondents frequently noted inconveniences. These included problems with the payments system (especially lack of access to cash via ATM), Internet problems (little access to Wi-Fi and slow speed), limited English translation of signage and tourist information at tourist attractions, and electricity outages (Uzbekistan Tourism Insight. World Tourism Organization, 2014). Furthermore, as noted in an interview with a local tour guide conducted by Silk Road New Observation News Agency, concerns about the wholesomeness of food products, the availability and quality of medical services, and the lack of clean, modern public restrooms are frequently cited (Senior tour guides interpret Uzbekistan's tourism status, 2019). Because of the often poor medical services in outlying areas, tourists who fall ill in these locales need to be moved swiftly to Tashkent's international hospital. At the same time, the practice whereby a tour group will wait for the patient to recover and then depart the country all together can produce large costs and additional concerns for fellow tourists and their travel agency as they wait for the patient's treatment to end.

### **Development of digital tourism**

In accordance with global trends, the total number of Internet users in Uzbekistan has exceeded 22 million, and the number of mobile Internet users has exceeded 19 million (Khurramov O.K., 2020). In addition, the number of mobile base stations is increasing, and the throughput of the international data network is increasing. These indicators of digitalization in the economy of our country make it necessary to develop digital tourism in Uzbekistan.

Khurramov (2020) states that it is advisable to highlight the following priorities for the development of digital tourism in our country:

- a) Development of tourism info structure in combination with tourism infrastructure.
- b) In order to increase the current competitiveness of specialists and employees of tour operators and travel agents, hotels and restaurants, transport and other tourism enterprises of the country, it is necessary to regularly participate in the training seminars and trainings of local experts and foreign experts in digital knowledge and modern information technologies like digital marketing, opportunities e-business, Google Analytics, Yandex Metrica, social networks, Facebook, Instagram, WhatsApp, Telegram, email marketing, mobile marketing (QR-code, mobile application), online advertising, and so on.
- c) To overcome the backwardness of economic enterprises and organizations in the field of economic relations and management in the country, it is necessary to transform its activities through communication with consumers, the introduction of new forms of electronic payments.
- g) Support for research, applied research, the development of textbooks, study guides and guidelines for the development of digital tourism in Uzbekistan will contribute to further improvement of this area.

The digitization in tourism makes the tourism business not only adapt to modern events, but also be more competitive in the developing "digital world". Digitalization of the hospitality industry



not only gives us convenience and benefits for our customers, but, in turn, helps to create a situation that allows owners of travel companies to earn more.

### **Using world experience in tourism development of Uzbekistan**

The Uzbek Government and the tourism stakeholders can exploit the experiences of European destinations in question and adopt some of their successful strategies. A recommendation for the achievement of sustainable tourism development in Uzbekistan, based on the research conducted and the observations made in the tourism sectors of the UK, Greece and the Czech Republic is that the Uzbek Government should formulate a long-term development framework for tourism (10-20 years) with emphasis on: proper policy, strategy and planning; institutional strengthening; new legislation and regulations; product development and diversification; effective marketing and promotion; improvement of tourism infrastructure and superstructure; increase of the tourism investments; human resources development; and, the expected socio-cultural and environmental impacts of tourism (Kapiki, S.T. and Tarikulov, M, 2014). Moreover, a short term (three-year) action plan is essential for priority actions to be undertaken so as to kick-start sustainable tourism development, and preparation of several demonstration projects for pilot areas.

### **CONCLUSION**

Building a bigger, more developed, more internationally competitive tourism market can help Uzbekistan's economy grow, just as tourism has been an engine of growth in western European and other countries. It can also have domestic social, cultural, and education benefits in addition to boosting a country's international reputation and identity. Uzbekistan has already made its national strategy, "Concept of the Development of the Tourism Industry — 2025," a guide and framework. The government has approved its Action Plan for 2019 for implementing the Concept. The Action Plan contains 36 points, including improving the regulatory framework, further developing the tourism infrastructure, developing transportation networks, establishing a regular intercity bus service, and organizing protected zones. The infrastructure construction will lay a solid foundation for the tourism industry and thus provide better service for tourists from all over the world (Advantour, 2019).

Therefore, the Uzbek government should provide more space for the private sector, especially foreign partners who have more experience and capital. At the same time, foreign private sector actors should look at the opportunities they have — from facilities such as hotels, shopping centers, and restaurants, to services such as travel agencies, taxis, and online services for ride-sharing or hailing rides, and obtaining lodging reservations. Additionally, beautiful and varied Uzbek handicrafts and local agricultural and food products are very popular among foreign tourists. The private sector can, in addition to establishing and providing such goods and services, can also help provide a standardized system of marketing and sales channels to boost profits and foreign-currency receipts. A further benefit to a growing role for the private sector in Uzbekistan's tourism industry is to help empower women and promote gender equality in Uzbek society.

Efficient and effective advertising and informational campaigns are also important for attracting tourists. The government can open accounts on social-media platforms or invite world-famous tourist programs/personalities to work in Uzbekistan and introduce the country to foreign-media consumers.



**REFERENCES**

1. Advantour (2019) Tourism International Forum. Available at: <https://www.advantour.com/uzbekistan/tashkent/exhibitions/tourism-investforum.htm> [Accessed: May 14, 2021]
2. Ashworth, G.. J. and Goodall, B. (1988): "Tourist images: Marketing Considerations". In Goodall, B. and Ashworth, G. (Eds.).Marketing in the tourism industry – the promotion of destination regions.Beckenham.Croom Helm: 213-237
3. AzerNews (2019) Uzbekistan sees fivefold increase in tourism industry. Available at: <https://menafn.com/1098270663/Uzbekistan-sees-fivefold-increase-in-tourism-industry> [Accessed: May 14, 2021]
4. AzerNews (2020) Uzbekistan sees fivefold increase in tourism industry. Available at: <https://menafn.com/1098270663/Uzbekistan-sees-fivefold-increase-in-tourism-industry> [Accessed: May 14, 2021]
5. Bigné, E., Sánchez, M.I. and Sánchez, J. (2001). "Tourism image, evaluation variables and after purchase behaviour: inter-relationship". *Tourism Management* 22: 607-616.
6. Chan, T., Milne, S., Fallon, D., and Pohlmann, C. (1996). "Urban Heritage Tourism.The Global-local Nexus".*Annals of Tourism Research* 23 (2): 284-303.
7. Embassy of the Republic of Uzbekistan to the United Kingdom of Great Britain and Northern Ireland (2019) Available at: [http://www.uzbekembassy.org/e/tourism\\_in\\_uzbekistan/](http://www.uzbekembassy.org/e/tourism_in_uzbekistan/) [Accessed: May 5, 2021]
8. Goodrich, J. N. (1978b). "A new approach to image analysis through multidimensional scaling".*Journal of Travel Research* 16 (3): 3–7.
9. Handbook on E-marketing for Tourism Destinations (2008) World Tourism Organization. Available at: [www.unwto.org](http://www.unwto.org) [Accessed: May 10, 2021]
10. Kantarci, K. (2007a). "Perceptions of Central Asia Travel Conditions: Kyrgyzstan, Kazakhtan, Uzbekistan and Turkmenistan". *JournalofHospitality&LeisureMarketing*15 (2): 55-71.
11. Kapiki S,T. and Tarikulov, M (2014)Development Prospects of Uzbekistan's Tourism and Hospitality Industry by Utilizing the EU Experience. Available at: <https://www.researchgate.net/publication/270512207> [Accessed: May 5, 2021]
12. Khamidov, O. (2017). "New Stage of Tourism Development in Uzbekistan: Actual Problems and Perspectives. World Science News.[Online] Available at: <http://www.worldscientificnews.com/wp-content/uploads/2017/08/WSN-863-2017-134-149.pdf> [Accessed: May 14, 2021]
13. Khurramov O.K. (2020) Prospects of digital tourism development // *Economics*, 2020. № 1. C. 44.
14. Knobloch, E. (2013). *Treasures of the Great Silk Road. The History Press.*

15. Li, Ch-K., Kang, S., Reisinger, Y. and Kim, N. (2012). "Incongruence in Destination Image: Central Asia Region". *Tourism Geographies* 14 (4): 599-624.
16. Litvin, S. W. and Mouri, N. (2009). "A comparative study of the use of iconic versus generic advertising images for destination management". *Journal of Travel Research* 48 (2): 152-161.
17. Senior tour guides interpret Uzbekistan's tourism status (2020) Available at: <http://www.siluxgc.com/UZ/20180912/15177.html> [Accessed: May 5, 2021]
18. Silk Road Destinations (2019) About Uzbekistan. Available at: <https://web.archive.org/web/20150402090252/http://en.silkroaddestinations.com/about-uzbekistan/> [Accessed: May 10, 2021]
19. Travel Wire News (2019) Uzbekistan aims at a breakthrough in tourism development in 2019. Available at: <https://travelwirenews.com/uzbekistan-aims-at-a-breakthrough-in-tourism-development-in-2019-1266618/> [Accessed: May 15, 2021]
20. UNWTO (2014) Silk Road Programme, Declarations. Available at: <http://silkroad.unwto.org/en/content/declarations> [Accessed: May 15, 2021]
21. World Tourism Organization (2014) Uzbekistan Tourism Insight. Available at: [http://cf.cdn.unwto.org/sites/all/files/pdf/150910\\_uzbekistan\\_visitor\\_economy\\_survey\\_jc\\_final.pdf](http://cf.cdn.unwto.org/sites/all/files/pdf/150910_uzbekistan_visitor_economy_survey_jc_final.pdf) [Accessed: May 5, 2021]

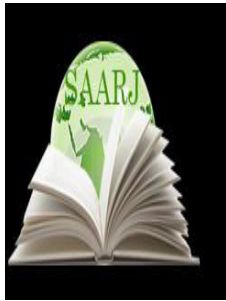

**ACADEMICIA**  
**An International**  
**Multidisciplinary**  
**Research Journal**  
 (Double Blind Refereed & Peer Reviewed Journal)

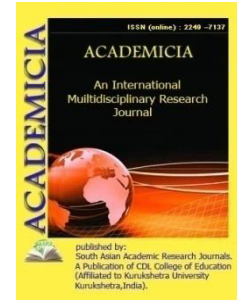

**DOI: 10.5958/2249-7137.2021.01935.2**

## MATHEMATICAL MODELING IN HYDROGEOLOGICAL RESEARCH

**Sh.S.Akhralov\* ; J.J.Jumanov\*\***

<sup>1,2</sup>Mathematical Modeling In Hydrogeological Research,  
 UZBEKISTAN

### ABSTRACT

*In the article the application issues of geographic information technologies and methods of mathematical modeling of geofiltration and geomigration processes of hydrogeological systems were discussed, as well as for information support of the groundwater monitoring system. The object of research are the Akhangaran aquifer, which is a large industrial area with intensification of agriculture, as well as densely populated, where industrial reproduction of water resources is established by designing water intake facilities using groundwater, also having huge data on regime, geological and hydrogeological aspects. The main goal of these researches is to learn the methodology for assessing groundwater resources by modeling to the GIS basis, theoretical and applied methods of mathematical analyses. The features are considered and the boundary and initial conditions are justified. The results are a research technique has been developed to simulate geofiltration and geomigration processes, to determine the balance of groundwater, and the hydro geological parameters of the aquifer have been calculated from it. The calculated values of the natural resources of groundwater by the parameters of their level mode in the Ahangaran pool allowed establish the permissible convergence of resource estimates according to the amplitudes of fluctuations in the level of groundwater and according to geoinformation modeling.*

**KEYWORDS:** *Mathematical Modeling, Geofiltration Processes, Geoinformation Technology, Topographic Surfaces, Groundwater, Geofiltration Schematization, Finite-Difference Schemes, Monitoring Of The Underground Hydrosphere.*

### INTRODUCTION

Groundwater is the property of the state and is enshrined in laws "On Nature Management", "On Subsoil", etc. In the arid climate of the Republic of Uzbekistan, the main suppliers of fresh water suitable for drinking are river valleys. Significant groundwater reserves are concentrated in them,

which are formed mainly due to filtration losses from surface watercourses and irrigation water infiltration [10, 11, 19].

An important direction of increasing the efficiency of the geological, agricultural and industrial sectors of the economy is the use of modern geographic information technologies for the information integration of processes. According to various estimates, up to 80% of the production cycle time is spent on the preparation and support of design models in high-tech production. This is related primarily to the high labor input and complexity of preparing the initial (visual-figurative) information. At present, mathematical and geoinformation models are being created in various areas of geological and hydrogeological science, and thematic electronic maps are also widely used. This product is becoming one of the common forms of presenting various kinds of information [5, 7].

ESRI geographic information systems (GIS)(ArcGIS, ArcInfo, ArcView, etc.) in such tasks are a powerful tool for data integration and analysis [5]. With GIS technology, a development process is now occurring that is characteristic of the entire history of science and technology. Needs push to the creation of some visualized database, technical and information system for solving the problems of geology, reclamation hydrogeology and engineering geology.

There are various methods of geoinformation modeling, surface construction, topographic analysis and handling of inaccurate quantities, i.e. fuzzifications. Fuzzification is the establishment of a correspondence between the specific, usually numerical, value of a single input variable of a fuzzy inference system and the value of the membership function of the corresponding term of the input linguistic variable. When specifying for elements of a set the corresponding degree of belonging to this set, the theory of fuzzy sets is used, which was first proposed by the American mathematician L.Zadeh [15]. At present, the theory is actively developing, new scientific concepts and its applied areas are being formed. There is a tendency toward integration into a general theory of uncertainty analysis, where operations with fuzzy sets are one of the main ones. That is, information is turning into a general scientific concept, including the exchange of information between people, a person and a machine, the exchange of signals in the geological and plant world; transmission of signs from nature, from the geosphere to the computer; becomes one of the basic concepts of information and communication technologies.

Conducting research, evaluation and monitoring researches by traditional methods is associated with high labor and material costs, subjective dependence on the executor and the timeliness (inertia) of information; therefore, solving modern, complex engineering problems based on new computer technologies for three-dimensional modeling is an urgent problem.

*Review of research.* At leading research centers in the Netherlands, Denmark, Germany, Canada, Russia, and others, a number of software packages have been developed that focus on modeling hydrogeological systems, such as Visual MODFLOW (USA), Groundwater Modeling System (GMS), combining MODFLOW models, Brigham Young University laboratories, Ground Water Vistas GWV DHI (Denmark), ModTech developed by Geolink Consulting (Russia), “the GWFS Geofiltration Modeling” software system. A number of researches were carried out on the application of finite-difference and numerical methods for modeling the geofiltration processes of groundwater, including [5]:F.B.Abutaliev, J.Fried, I.K.Gavich, A.A.Samarsky, V.M.Shestakov, L.Luckner, U.U.Umarov, J.C.Refsgaard, L.M.Milne-Thomson, W.Kinzelbach,

N.N.Verigin, I.Khabibullaev, P.Ya.Polubarinova-Kochina, I.I.Krashin, R.N.Usmanov, V.M.Mironenko, V.M.Godberg, I.N.Tikhonov, J.H.Djumanov and many others. There are separate developments on mathematical modeling of the relationship of geofiltration processes according to the scheme formation  $\leftrightarrow$ transit zone  $\leftrightarrow$  unloading zone (K.Fletcher,E.Oran, F.M.Bochever, D.Anderson, L.S.Yazvin, A.M.Soifer, I.Ber, A.B.Vistelius, J.Kh.Djumanov and others) [6]. With the advent of GIS technologies, it gave a personal impetus to the development of a mathematical modeling methodology for large regional hydrogeological objects, which allow integrating mathematical models of local parts of large hydrogeological objects on the basis of a unified computing system R.F.Tomlinson, A.M.Trofimov, A.D.Armand, A.M.Berland, A.V.Koshkarev, etc.

Modern software packages with a convenient interface on the one hand make an important contribution to the development of a geofiltration modeling methodology based on the widespread use of information technology [9], and on the other hand, they are focused mainly on the use of factual, numerical information in the modeling process of weakly formalized processes in hydrogeology.

*The object of our research* was the Akhangaran groundwater field, which is a large industrial unit with intensification of agriculture, as well as densely populated, where industrial reproduction of water resources is established by designing water intake facilities using groundwater in the Tashkent region.

*The main goal* of these researches is to transfer the methodology for assessing groundwater resources by modeling geofiltration and mass transfer to the GIS basis and to introduce this model using the example of the Akhangaran river valley. To achieve the goal, the following tasks were solved.

*Formulation of the problem.* These researches are a development of the methodology of mathematical modeling of hydrogeological processes. Of particular note are the merits of scientists from TUIT and the HYDROINGEO Institute: N.N. Khodjibaev, F.B. Abutaliev, U. U. Umarov, I.Kh. Khabibullaev, R.N. B. Bahramova, P. P. Nagevich, A. B. Alimbaev, J. Kh. Dzhumanova, I. N. Gracheva and others, who made a great contribution to the establishment, development and implementation of a methodology for modeling hydrogeological processes and it is worth noting that At this stage of research, five doctoral and ten master's theses have been prepared and defended [19].

Recently, changing the mode of surface water flows in the Akhangaran Valley and increasing requirements for the rational use of water available against the background of a general shortage of water have led to the identification of a special class of problems in modeling geofiltration and geomigration processes of regional hydrogeological systems in disturbed natural and technogenic conditions [7, 13, 17].

Since in real time mode it is planned to solve a number of problems related to the schematization of the filtration area, the integration of geofiltration and salt transfer models, their finite-difference representations, the formalization of fuzzy parameters and characteristics on a fuzzy-determined basis, the synthesis of thematic layers in the process of solving applied problems, geographically dependent interpretation of data obtained from different horizons and thematic tasks, etc. [8, 15]. In the main hydrogeological studies, where the use of mathematical modeling methods for geofiltration and geomigration is considered mandatory, these are the conditions of

reclaimed territories and their mineralization, assessment of water resources and monitoring, protection of groundwater from pollution, i.e. modeling of hydrogeological processes in the conditions of uncertainty of the initial information.

To simulate mass transfer, as a rule, various equations of convective-diffusion type are used. Moreover, studies show [2, 4] that in real conditions the convective component of flows prevails. Usually, groundwater geofiltration is primarily modeled, and the result of this simulation is used to model mass transfer problems, etc. improvement of methods of hydrogeological models of groundwater fields based on modern geoinformation technologies [5].

Substance transfer in a moving groundwater flow, i.e. geomigration, the processes of the substance transfer and heat by groundwater are determined, which are conditioned by the following basic phenomena as convection, diffusion, as well as by the physicochemical processes of the interaction of groundwater with mountain rocks (Abutaliev F.B. 1980, [1, 4, 16]):

1. Convective transfer by a filtered flow (forced convection) under the influence of a hydraulic gradient, proceeding at a speed  $u = v/n$ , where  $v$  is the Darcy filtration rate and  $n$  is porosity. The specific flow of substance (mass of substance moving in a unit volume of rock per unit time) due to convective transfer  $I_k = uC$ , where  $C$  is the content in the solution or concentration.
2. Density convection associated with the presence of a vertical density gradient of solutions. Its speed is  $v_\rho = K_z \Delta \rho$ . In this expression,  $v_\rho$  is the vertical component of the filtration rate due to the density gradient,  $K_z$  is the filtration coefficient in the vertical direction, and  $\Delta \rho = (\rho_a - \rho_b)/\rho_b$ , where the indices "a" and "b" correspond above and below the underlying water. In this case, movement can occur only when the mineralization of a denser overlying solution is 2-5 g/l higher than that of a less dense solution below it. Specific flow  $I_\rho = v_\rho C$ .
3. Diffusion transfer obeying the Fick law  $I_{Df} = D_M \partial C / \partial l$ , where  $D_M$  is the molecular diffusion coefficient in a water-saturated medium, and  $l$  is the distance in the direction of the concentration gradient.
4. Hydrodynamic dispersion controlled by the dispersion coefficient  $D_v = \delta v$ . The dispersion coefficient  $\delta$  used here is determined by the size and the void structure of the rock, and the specific substance flow due to the dispersion  $I_{Dp} = D_v \partial C / \partial l$ . Since transfer due to diffusion and dispersion are physical analogues, the concept of the total dispersion coefficient  $D = D_M + D_v$  is introduced. In this case,  $I_{Df} + I_{Dp} = D \partial C / \partial l$  are defined together.
5. Given the salinization of aquifers of molecular diffusion and dispersion in order to study the movement of fresh groundwater and the migration of their pollutants, as well as the relationship with surface water, it is necessary to solve the following system of equations (Abutaliev F.B. 1980, , [1, 2, 4, 12]):

$$\text{and initial conditions (Cauchy problem)} \begin{cases} H(x, y, t_0) = \varphi(x, y); & t \geq t_0 \\ C(x, y, t_0) = \psi(x, y); & t \geq t_0 \end{cases} \quad (5)$$



where,  $\varphi(x,y)$ ,  $\psi(x,y)$  are the given functions,  $\Gamma = \Gamma_1 + \Gamma_2 + \Gamma_3 + \Gamma_4 + \Gamma_5 + \Gamma_6$  boundary.

In the equations of system (1)-(5),  $\mu$  is free water loss;  $H(x,y,t)$  - groundwater level in absolute grades,  $H_0(x,y,t)$  - water level in the channel, in m;  $\Phi(x,y,t)$  is the filtering resistance of the channel,  $m = H - b(x,y)$  is the power of the aquifer;  $k(x,y)$  is the filtration coefficient m / day;  $W_n = \sum_{i=1}^n W_i^n(x,y,t)$  is the intensity of various groundwater supply factors (including pollutants) with a concentration of  $C_n(x,y,t)$ , m/day;  $W_0 = \sum_{i=1}^n W_i^0(x,y,t)$  - groundwater flow rate (withdrawal, drainage, evaporation) from a certain concentration of  $C_0(x,y,t)$ , m / day;  $D_x = D_m + \lambda_x |v_x|$ ,  $D_y = D_m + \lambda_y |v_y|$  - component convective diffusion coefficients;  $D_m$  is the molecular diffusion coefficient, and  $\lambda_x, \lambda_y$  is the coefficient of longitudinal and transverse dispersion.

The dispersion of the fluid flow in a porous medium is the formation and development over time of the transition zone between the propagation regions of two phases of different composition.  $G = \sum_{i=1}^n \Gamma_i$ ,  $v(x,t)$  is the filtration rate determined by Darcy's law;  $F_1(x,y,t) - F_6(x,y,t)$  - defined functions.

*Numerical solution.* Filtration and salt solutions, i.e. systems (1) - (5) are searched sequentially using implicit finite-difference schemes [1, 12, 17]. In system (1) - (5) and boundary conditions, we pass to dimensionless variables by the formulas [1, 5, 7].

$$H^* = \frac{H}{H_0}; K = \frac{K}{T_0}; m^* = \frac{m}{H_0}; C^* = \frac{C}{C_0}; D^* = \frac{D}{H_0 T_0}; \phi^* = \frac{\phi}{R_0};$$

$$\xi = \frac{X}{L}; \eta = \frac{Y}{L}; \tau = \frac{H_0 T_0}{\mu L^2} t; W_n^* = \frac{\mu L^2}{H_0^2} W_n; W_0^* = \frac{\mu L^2}{H_0^2 T_0} W_0^*,$$

where  $H_0, C_0, D_0, R_0 T_0$  are some characteristic values of the pressure function, concentration, convective diffusion and filtration coefficient,  $L$  is the maximum extent in the region  $G$ . Since in what follows we deal with equations in dimensionless form, (\*) asterisks dimensionless variables omitted [6].

$$\begin{cases} \frac{\partial H}{\partial \tau} = \frac{\partial}{\partial \xi} \left( km \frac{\partial H}{\partial \xi} \right) + \frac{\partial}{\partial \eta} \left( km \frac{\partial H}{\partial \eta} \right) + W_n - W_0 \\ \frac{\partial(mC)}{\partial \tau} = \frac{\partial}{\partial \xi} \left( D_\xi m \frac{\partial C}{\partial \xi} - mv_\xi C_\xi \right) + \frac{\partial}{\partial \eta} \left( D_\eta m \frac{\partial C}{\partial \eta} - mv_\eta C_\eta \right) + W_n C_n - W_0 C_0 \end{cases} \quad (6)$$

Indices  $i, j, \tau$  are introduced and steps  $\Delta \xi, \Delta \eta$  and  $\Delta \tau$  along the  $x, y, t$  axes, respectively. Parts of the boundary with a condition of the first kind can be arbitrary, but with conditions of the second or third kind, they are taken as stepped lines with segments parallel to the coordinate axes. In the rectangle  $\xi_{i-0.5} \leq \xi \leq \xi_{i+0.5}, \tau_j \leq \tau \leq \tau_{j+1}$ , the balance equation for system is written (6).

$$\left\{ \begin{aligned} \frac{H_{i,j} - \bar{H}_{i,j}}{0,5 \Delta\tau} h &= \Lambda_{i-0,5,j} - \Lambda_{i+0,5,j} + \Lambda_{i,j-0,5} - \Lambda_{i,j+0,5} + (W_{n,i,j} - W_{o,i,j})h \\ \left( \frac{H_{i,j} - \bar{H}_{i,j}}{0,5 \Delta\tau} C_{i,j} + \bar{m}_{i,j} \frac{C_{i,j} - \bar{C}_{i,j}}{0,5 \Delta\tau} \right) h &= \aleph_{i-0,5,j} - \aleph_{i+0,5,j} + \aleph_{i,j-0,5} - \aleph_{i,j+0,5} + \\ &+ (W_{n,i,j} C_{n,i,j} - W_{o,i,j} C_{i,j})h, \end{aligned} \right. \quad (7)$$

where,  $\Lambda_{i-0,5,j} = -(km)_{i-0,5,j} \frac{H_{i,j} - H_{i-1,j}}{\Delta l}$ ;  $\Lambda_{i+0,5,j} = -(km)_{i+0,5,j} \frac{H_{i+1,j} - H_{i,j}}{\Delta l}$

$$\aleph_{i-0,5,j} = - \left[ (Dm)_{i-0,5,j} \frac{C_{i,j} - C_{i-1,j}}{\Delta l} - (\Lambda)_{i-0,5,j} CL_i \right],$$

$$\aleph_{i+0,5,j} = - \left[ (Dm)_{i+0,5,j} \frac{C_{i+1,j} - C_{i,j}}{\Delta l} - (\Lambda)_{i+0,5,j} CR_i \right],$$

$(mv)_{i,j \pm 0,5}$  and  $\aleph_{i,j \pm 0,5} \bar{h}_{i,j} = h_{i,j}^{k+1}$ ,  $\bar{C}_{i,j} = C_{i,j}^{k+1}$ , the values of the concentrations of  $CL_i$  and  $CR_i$  at the flow points are calculated through the values of the concentrations in the neighboring nodes depending on the direction of the velocity between these nodes, using the countercurrent method [2,4, 5].

the approximation of the boundary conditions of the second and third kind is considered separately. Using the balance method, the difference approximation of the boundary conditions (BC) (2) and (4) is given in mind.

$$\begin{cases} H_{0,j} = \kappa_{1,j} H_{1,j} + \nu_{1,j} \\ C_{0,j} = \kappa'_{1,j} C_{1,j} + \nu'_{1,j} \end{cases} \begin{cases} H_{N,j} = \kappa_{2,j} H_{N-1,j} + \nu_{2,j} \\ C_{N,j} = \kappa'_{2,j} C_{N-1,j} + \nu'_{2,j} \end{cases} \quad (9)$$

$$\kappa_{1,j} =$$

To provide a positive solution to problem (8), certain conditions are imposed on the time step  $\Delta t$ . In [4,5], this condition has the  $\Delta\tau = \mu \frac{\Delta x^2}{T_o H_o}$ . To solve the system of equations (8), we apply the sweep method, according to which the solution is found in the form

$$\begin{cases} H_{i,j} = \alpha_{i+1,j} H_{i+1,j} + \beta_{i+1,j} \\ C_{i,j} = \alpha'_{i+1,j} C_{i+1,j} + \beta'_{i+1,j} \end{cases} \quad (10)$$

For  $i = i-1$ , we insert equation (10) into (8) after some algebraic transformations, the equation for  $\alpha_{i+1,j}$ , and  $\beta_{i+1,j}$ ;  $\alpha'_{i+1,j}$  and  $\beta'_{i+1,j}$  are obtained.

$$\text{where, } \begin{cases} \alpha_{i+1,j} = \frac{c_{i,j}}{b_{i+1,j} - c_{i,j} \alpha_{i,j}} \\ \alpha'_{i+1,j} = \frac{c'_{i,j}}{b'_{i,j} - a'_{i,j} \alpha'_{i,j}} \end{cases}, \quad \begin{cases} \beta_{i+1,j} = \frac{a_{i,j} \beta_{i,j} - d_{i,j}}{b_{i+1,j} - c_{i,j} \alpha_{i,j}} \\ \beta'_{i+1,j} = \frac{a'_{i,j} \beta'_{i,j} - d'_{i,j}}{b'_{i,j} - a'_{i,j} \alpha'_{i,j}} \end{cases}$$

Thus, all values of  $H_{N,j}$  and  $C_{N,j}$  are determined over the entire area of geofiltration and geomigration. Therefore, using the above schemes, it is possible to study the processes of

groundwater movement and the relationship with surface water and changes in the concentration of fresh water pollution, both in space and in time.

The developed mathematical model has been introduced to solve national economic problems in certain regions of the Republic of Uzbekistan; for this, a method for calculating individual articles of groundwater balance has been carried out. At a specific object, using the example of the Akhangaran underground water fields for a certain period of time, a balance is determined (annual average, seasonal, average long-term, etc.). The balance consists of water inflow (infiltration, groundwater inflow into the balance circuit, overflow from other aquifers) and water flow (groundwater outflow, withdrawal, wedging - hidden in rivers, drains and open - spring; total evaporation). In the research area, a significant amount of infiltration occurs not only from water bodies, but also from the irrigation network and during irrigation of land (and plantations) [7, 10, 11].

*Typization and schematization.* Typization is the allocation of the same type of sites according to hydrodynamic features and possible design schemes. They are distinguished by the generality of the flow structure, bedding conditions and the hydraulic state of aquifers, by the generality of the reservoir structure and the boundary conditions acting on them.

Schematization - identifying the main factors; -determining the most reliable scheme of the structure of the reservoir and the calculated values of the parameters; - simplification of filtration and replacement of spatial by planned or plane-vertical; - simplification of the forms of borders and laws of change in them levels and costs of flows. In schematization takes into account the physical and theoretical foundations of the processes under study. First, the type of filtration, the flow dimension, and the size of the studied region are estimated, then the structure composition of the studied complex, the internal and external boundaries, and boundary conditions are established.

*Conducting experiments.* In general, geomigration modeling includes several successive interconnected steps: 1) Geofiltration calculation, which determines the water level, and then the speed of movement of solutions and the components contained in them in the direction of the coordinate axes at time  $\tau^k$ . 2) Independent calculation of the dispersion component of mass transfer by  $\tau^k$  for  $\Delta\tau$ . 3) Independent calculation of the action of effluents of a substance, including the calculation of interactions in the water – rock system, at the same time step. As a result of calculations, in accordance with geofiltration, the distribution in the calculation nodes of the current levels, as well as the compositions of other calculated parameters of the liquid phases, is determined, after which all the calculations for the next time step, etc., are repeated until a specified final point in time is reached.

Based on the developed modeling programs for estimating forecast resources taking into account changes in water management conditions, the results on the current state of groundwater fields were obtained and recommendations were made on the use of groundwater for irrigation in order to increase the water supply of the valley (Fig. 1). Unlike the traditional presentation, the electronic version of the results is presented by means of a geographic information system (GIS), and the possibility of developing the contents of an electronic map in a semi-automatic mode has been implemented [6, 8].

It should be noted a natural increase in the salinity and pollution of groundwater from the floodplain to the sides of the valley. The location within the valley of large industrial facilities

from whose territory sewage contaminated water comes, as well as irrigated agriculture with the use of fertilizers, pesticides, herbicides create an unfavorable sanitary condition of groundwater. Deterioration of surface water and groundwater in the river valley. Ahangaran has been observed since 1967. An increased content of nitrite phenols was found in the water intakes of Kibray, Yuzhny, Sergeli, Yangiyul. The upper part of the aquifer outside the floodplain is contaminated with nitrates (0.5-1.0 MPC). Three types of groundwater modes are distinguished in the Ahangaran valley: hydrological, irrigation, and mixed [7, 11].

Taking into account the level, area and specific features of the manifestation of the impact and their consequences, technogenic objects are divided into:

- irrigation systems;
- systematic reclamation drainage systems;
- reservoirs and large hydraulic units;
- large irrigation canals;
- groundwater intakes.

The structural block diagram of the model is based on separate maps of the depths of the soles of the assigned layers relative to the surface of the relief (Fig. 1). The geometry of the terrain model is determined by the coordinate system in which the digital surface model is created. The choice of a local rectangular coordinate system makes it possible to simplify the combination of terrain models and urban objects that are created in a rectangular coordinate system. To enter the absolute elevation of the earth's surface into the model, we used the shp file of relief contour lines prepared in ArcGIS in the Gauss-Krueger metric coordinate system (Pulkovo, 1942), from which, by interpolation, the absolute elevation marks were determined in each cell of the model grid [5, 20]. To specify the roof and sole of each selected layer in the model, .xls-files were used that contained the absolute marks of the roof and the sole of each layer at anchor points with known coordinates.

To form a geofiltration model, filtration coefficients were introduced for each calculation layer. During the solution, the water conductivity is calculated using the entered filtration coefficients and the absolute marks of the upper and lower boundaries of each layer.

*The discussion of the results.* As a result of the work, several versions of the photorealistic model were obtained, but these are only the first steps towards a comprehensive system that provides for the possibility of geofiltration and geomigration modeling, as well as three-dimensional display of the results of modeling of research territories (Fig. 2).

Operational monitoring, the most characteristic for the boundary representation, is considered; calculation of the overall volume; calculating the normal at a point; calculation of surface curvature; finding the point of intersection with the beam or curve; determining the position of a point relative to the surface.

The basic operations include transforming materials on a GIS basis and creating a primitive, its modification, local modification of curves and surfaces, automatic construction of fillets, joints and cross-linking of surfaces, automatic search for intersections, rotation, extrapolation of data,

as well as transforming an object into a plane [6, 20 ]. Surface modeling is the basis for the construction of geofiltration and geomigration models, nodes and the integration core.

## CONCLUSION

The tasks of geofiltration and geomigration modeling of groundwater and visualization is an important area of computer graphics. Since data on physical objects of the real world cannot be entirely entered into a computer, it is necessary to a priori limit the amount of information about an object within the framework of the issue of interest to us. For example, the task of GIS rendering an object with shading raises such problems as: Mineralization and mass transfer of the underground hydrosphere, how to visualize, What parts of the object are visible?, What color should be assigned to each element of the object?

In a generalized form, it looks as follows: the characteristic of the projection apparatus, the construction of images of the main geofiltration and geomigration elements, the work with the constructed images in accordance with the geographic coordinate reference.

A research technique has been developed to simulate geofiltration and geomigration processes, to determine the balance of groundwater, and the hydrogeological parameters of the aquifer have been calculated from it. The features are considered and the boundary and initial conditions are justified.

## REFERENCES

1. Umarov U. U. "Methods of mathematical modeling of hydrogeological processes" Tashkent: Fan. 1966.-p.112
2. Umarov U. U. Automation information retrieval system "Land reclamation hydrogeology" and permanent models. – Tashkent: Fan. 1978. -p.120
3. Usmanov RK, Dzhumanov Zh.Kh., Rasulev BT, On the integration of the fuzzy-plural approach into the process of numerical modeling of the hydrogeological conditions of the Kibray water intake // Ecological Bulletin. –T. 2007 No. 8. -pp.37-39
4. Fletcher K. Computational methods in fluid dynamics. - M.: Mir, 1991.- T.1, 2. - p.552
5. Khabibullaev I. Numerical modeling of groundwater filtration of irrigated massifs and application packages. -T.: Fan. 1991.-p.115
6. Rakhmatullayev Sh, Frederic H, Kazbekov J, Philippe C. Djumanov J. Groundwater resources of Uzbekistan: an environmental and operational overview // Central European Journal of Geosciences // SPRINGER-Versita. Germany 2012. No4 (1) -pp. 67-80
7. Hasanov A.S. Development of hydrogeology and engineering geology in Uzbekistan. – Tashkent: HYDROINGEO, 2005, -p.212
8. Yurkov V.Yu. Interval and fuzzy geometry in the system of development and diagnosis of the spatial factor of intelligence / Omsk Scientific Bulletin. 2006. - No. 2 (35) -pp. 96-99.

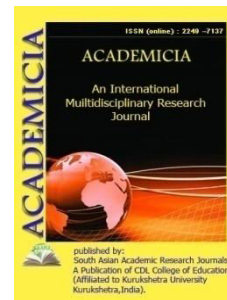
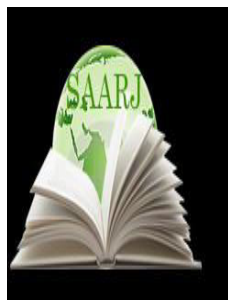

DOI: **10.5958/2249-7137.2021.01936.4**

## SEMANTICS OF THE LEXEME “GREEN”

**Israilova Saodat Turapovna\***

\*Faculty of Journalism,  
Chair of Uzbek linguistics, National University of UZBEKISTAN  
Email id: israilovas404@gmail.com

### ABSTRACT

*Study of use of color in the work of fiction and how the described idea is reflected are the topic subjects. The degree of study of color in Uzbek language is studied through classification of words defining colors in the novel, various approaches and situations in use of colors, degrees of equivalence in symmetric and asymmetric relations between the original work and translation. The words defining colors, their use in Uzbek are the subject of the field of concept describing the color symbolism in the original work and translation. The subject was studied in the linguistics of the science of translation, comparative analysis of the conceptual and original and translated text. The novelty of the research is the study of interlingual asymmetry in the use of colors in the translation of the work of fiction. The scientific/theoretical conclusions gained in the process of this research are theoretically and practically important in addressing the colors and problems related to them. The research consists of introduction, three chapters, summary, the list of references and attachment.*

**KEYWORDS:** *Color, Symbolism, Comparative Analysis, Conceptual, Theoretically, Practically, Linguistics*

### INTRODUCTION

Language is the spiritual wealth of the nation. Language is not only a means of communication, but also the culture, tradition, lifestyle and history of the people. Language is the mirror of the nation, the cradle of culture. The nation who cannot save one's language will become the most miserable, the poorest nation. Love for the language is an enchanted sense that absorbed into the human blood by mother's milk. Whatever is there in the world, all needs caring and preserving. So does the language. It is natural that the biggest responsibility will be given to the linguists. As the great Kyrgyz writer Chingiz Aytmatov noted, "Each of us is indebted to the Mothers who



raised us and gave us their most valuable wealth – language. If we put all our energy into the purity and enrichment of our language, then we could do our duty”.<sup>1</sup>

It is known that, colour is one of the means of realizing and ordering the world. It doesn't always function as the natural sign of an object. It shows the existence of an idea. Therefore every colour has a certain aesthetic value. Colour is a means influencing on the spirit of human, it may awaken the feelings of happiness and despair, vigor or sadness, contentedness or worry in human.

In linguistics the words denoting colour, mainly, have been studied in adjectives. The history of studying the words related to this group dates back to the very ancient times. In “Devon-ulugatitturk” by MakhmudKoshgariy, “Mukaddimat-uladab” and “Asos-ulbaloga” by MakhmudZamakhshariy, “Muhokamat-ullugatayn” by AlisherNavoi there were certain opinions about the sign features of adjectives, their opportunities of making different similes and literary arts.

In particular, in “Kutadgubilig” we can see the special attitude of YusufXosHojib towards the colour of red. “Red” is not just the symbol of beauty, it is symbol of the Sun in the culture of the East. This phenomenon can be seen in the Japanese, Korean and Chinese mythology and literature too. The colour of red was contrasted to the colours of black, yellow and green and beautiful literary images were created. According to the author of the article B.Tukhliev, there was the meaning of “the other world” in green besides the meaning awakening and youth.<sup>2</sup> Actually greenness is imagined in relation with the spring, awakening, action and good deeds. Even, it is known that Hizralayhissalam who gives long life to people is also imagined in green clothes. But there is another mythological meaning of the green too that it connects with the other world. In the epos of “Manas”(the face turns blue or green) and in “Khamsa” by Navoiy(tragedic end of the king Bakhram's life) we can see it.

As it was stated in S. Utanova's article, in “Devon-u lugatitturk” by MakhmudKoshgariy examples frowere given too:

“Qilnu bilsa kizil kizar  
Japanu bilsa jashil kizar”

It means, when women want to talk with their husbands, they wear red silk dresses, while begging and flattering they wear green dresses. This proverb about women is used to gain one's goals and to remind being polite. Due to a number of such reasons colour got a certain position. In fact, realizing beauty is, at the same time, being aware of the secrets of colour. In a literary work it not important what to describe, but how to describe is, the role of colours is immense in this case.<sup>3</sup>

In the works of AlisherNavoiythe colours were very masterly used. In S.Utanova'sarticle “Semantics of the colour of yellow in the lyrics of AlisherNavoiy” the semantics of the lexeme “yellow” used in the poet's ghazals are focused on. From the ancient times our ancestors considered the colour of yellow to be the cure for hepatitis. Therefore the patient was dressed in yellow and the room which the patient was lying in was equipped with yellow things.

The Prophet Muhammad (sav) wore yellow turban too when he went to see a patient. Because the colour of yellow is the symbol of the ray of the sun, warmth and high mood. But the colour of yellow doesn't treat the lyric hero of Navoiy, vice versa, yellow coat of his lover causes to

increase his pain. The lyric hero becomes sick shedding bloody tears over separation and his face gets yellow.<sup>4</sup>

In the works of Alisher Navoiy the colour of black has its own place. As it is stated in the article “About the interpretation of black colour again” by Ibrohim Hakkul, the black colour expresses the meaning of greatness in Navoiy’s works.<sup>5</sup>

In the 60s the linguist M. Sodikova added her great contribution to the study of the adjective words in Uzbek linguistics. In Uzbek linguistics the peculiarity of every scientific work concerning the study of adjectives, variety of investigation methods catch a sight. M. Ganikhujayeva, in her candidate dissertation work, investigated the adjectives denoting colour in the Uzbek language in comparative-historical way and defined their dynamics of development, layers of pure turkic and borrowed words denoting colour. The research results indicate that in the written monuments of the Old Uzbek language the words *red*, *blue* and *green* denoting colour were not used in figurative meanings, the word *black* which faced to substantivization was used in most eight meanings; the frequency of the use of the words denoting colour in the Uzbek language is the following: *black* – 18,8 %, *white* – 15,8 %, *red* – 6,89 %, *blue* – 3,5 %, *green* – 2,5 %, *yellow* – 2,5 %.

Jumatova N. in her article “Symbolic images related to colour in Uzbek folk proverbs” analyzed the proverbs in which the colours “white” and “black” participated in all aspects. She focused on the beauty of colours in the proverbs and sayings that have been formed for thousand years.

Symbolic study of colour continued later too. N. Mirzayeva’s article “Symbols of colour in the poetics of A. Chekhov and A. Kahhor is among them. In the article harmony of colour and light in the poetics of A. Chekhov is greatly focused on. Abdulla Kahhor continued this tradition and found a particular way of “making beautiful” the text by means of colours. Red has a special significance in the works of A. Chekhov, and in the poetics of Abdulla Kahhor “happy” feeling – hope, love and happiness are expressed by the colour of blue.<sup>6</sup>

In phraseological units, one of the units of folklore, colours are of significance too. In G. Ismoilov’s article “Idioethnic signs of the concepts of white and black in phraseological units” the difference of white and black colours used in phraseological units was studied in comparison in Uzbek, Kazak and Karakalpak languages.<sup>7</sup> Certain relationships are expressed by means of the concept of colour in Turkic nations too. It can be seen by the example of white and black, that’s they are divided into common human associative semas such as white “good deeds, purity” and black “cruelty” (symbols, often, occur in phraseological units).

Among the lexemes denoting colour “black” and “white” were greatly highlighted and studied more. Also, the lexeme “blue” is rich in meaning too. In Alisher Navoiy’s work “Muhokamat-ullugatayn” several meanings of the lexeme “blue” are mentioned too: “...vako’klafzin ham nechama’nabilaiste’molqilurlar. Biri ko’k—osmoni derlar. Yana ko’k ohangdur. Yana ko’ktegrada ko’klamdur. Yana ko’k qadog’ni ham derlar. Yana ko’k sabza va o’langni dog’i derlar. Bu nav alfoz hamki uch ma’ni va to’rt ma’ni va ortug’roqqim, iroda qilsa bo’lg’ay, ko’p borki, forsiy alfozda andoq yo’qtur...” Navoiy mentioned several meanings of the word blue such as sky, spring, grass.

The linguist S. Karimov gives important opinions about the use of the adjectives such as *go’zal* (beautiful), *oq* (white), *ko’k* (blue), *aziz* (dear) in the function of epithet in the poetry of

Zulfiya, her individual style and poetic skills. In the scholar's opinion, the poetess Zulfiya increased the demand for words in her works, tried to discover new meanings of them.<sup>8</sup> The researcher simultaneously continued his such delicate observations of epithets in his later works too.<sup>9</sup>

There given very many units, names of places related to the word blue in our linguistics. But whether they are really semantically connected with the lexeme blue or not has not been scientifically studied. For example, the toponym "Kukcha" is a place name that has existed since the ancient times up to now. It was noted in "TarixijadidaiToshkand" by Muhammad Solih that the term "Kukcha" was first mentioned in the 14th century in the list of the gates of Tashkent. Many people think that the word "ko'k" (blue) in this toponym is connected with colour. But, according to some researchers, it was taken from the word "kokhcha"- a small fortress, in another researchers' opinions, it was taken from the word "ko'hcha" – small mountain, hill, edge. As a result of the expansion of the territory of Binkat in the 11th and 12th centuries towards the West the Kokaldosh madrasah in the present Chorsu, the place where the KhujaAhrorjome mosque situated in, and the territories in the west and north of the edge behind them were improved and new residences, the future Kukcha district was founded.<sup>10</sup> Later, phonetically changed in public language, this place name was formed under the toponym of Kukcha. Another historical word Kukaldoshis often met when looking at the history. So, there arisen a question that what semantic connection of the lexeme blue is there under the meaning of this term. "Kukaldosh" in general means brothers which have nursed the same mother, a strange boy who has nursed the same mother with her own son. Thus, such brothers of the king were given the nickname of "Kukaltoshkhon". The term "Kukaltosh, as it is noted in "Giyosul-lugat" ("Helper of dictionaries"), contains the turkic words "ko'ka" ("a son of the nurse") and "tosh" or "dosh" ("partner"). The letter between these two words was added later, before there hadn't been "l".<sup>11</sup> Besides these terms, more units, toponyms and anthroponyms, which were formed on the basis of the word blue, can be given as an example that they haven't been completely studied historically and scientifically up to the present.

In the present Uzbek language we can see the following semantic opportunities of the adjective green:

1. Green, green growth, green grass: Qarshimdatebranarko'kbarglarharon(In every moment green leaves are shaking opposite me).
2. Grass: Yomg'irlar yog'ib, yerda o't-o'lan ko'rina boshladi, hayvonlarni og'zi ko'kka tegdi. Ko'kterishbahonasibilandalalarnitusayboshlaganedi.(Cho'lpon)(It rained and the grass began to appear on the ground, animals could eat the grass. With the reason for picking grass the fields began to be desired. )
3. spices: Ko'k solib qatqlangan mastavaning lazzatli hidi keldi. (A.Muxtor) (There was a sweet smell of soup with spices)
4. dollars: Birpachkako'kibilanqo'lgatushibdi, ishchatoq.(He was caught with a pack of dollars, it is grim.)

The word green as the attribute of the object denotes the colour of it and also can show the natural states of being unripe, green. *Ko'kuzum, ko'kqalampir, ko'kpiyoz, ko'kno'xat, ko'knovdava b.Birtupidaolmaendisarg'ayib, yiltiramoqda, birtupidamushtdayyirikolmalarko'm-*

*ko'k, ulargaboqishingbilantishinqqamashib, og'zinggaso'lakto'ladi.* (Oybek) (Green grapes, green pepper, green onion, green peas, green stalk and others. On one tree the apples are sparkling yellow, on another tree there are big green apples, as you look at them your teeth will set on the edges and make your mouth full of saliva)

In our language the sema of “green” is sometimes expressed by the lexeme *ko'k* (blue): *Yiroqdasamoviyufq... Ko'zio'ynaydi* (Boqar, boqar...) *Ko'nglisovub, Ko'ko'tchaynaydi*(M.Ali).(The sky blue horizon in the far. Eyes are playing (glancing, gazing...) Feeling disappointed, chews green grass). In this example the lexeme *ko'k* (blue, green) denotes the type (unripe, green growth) of the object. The same case can be seen when the lexeme green comes together with the word tea.

Or:

- *Ko'klamoyimko'kingdanberbirchimdim...* (Green Spring, give me your green a little)

Here the lexeme green denotes the season of Spring and its blessings besides the meaning of colour. The season of Spring is expressed by green and the blessings of it, particularly, mint, shepherd's purse, spinach and other plants are expressed by green too.

Every colour has its linguoculturological characteristics in the culture of every nation. It is defined according to the lifestyle, culture and social status of that nation in the society. Particularly, the colour of green is a unique symbolic colour in the world of Muslim. Besides, it expresses the signs of renewal. The colour red means the blood flowing in our body and expresses attractiveness, vivacity and stubbornness. The colour yellow sometimes denotes the meaning of gold, sometimes the meaning of illness. Colours are tightly connected with the social and cultural life, customs, ceremonies and ancient thoughts of any nations. Mythological and religious concerns of nations are also reflected differently in colours. Besides, social life of nations, geographical conditions lead to the variety of attitudes towards colours too. In particular, the Pole of the world are imagined in four colours: the East Pole is green, The South Pole is red, The North Pole is black and The West Pole is white. On this base these colours are sacred for the inhabitants living in every region.

The first forms of using symbolic images related to colours in our mentality and culture, mainly, found its reflection in folklore, public traditions and customs. It is known to us, folklore came into being before writing appeared, its creation and spread is connected with lively oral traditions. If we have a look at the historical roots of the symbols of colours which reflect traditional meaning in folklore, we can see the symbolic meaning of colours in the progress of human mind, that is in the awakening of the emotions like happiness and sadness, joy and grief in one's soul. Because, as Sh.Turdimov noted in his article “Colourful world”, colours are mostly like sounds in awakening emotions in human. They are not only limited by enriching the imagination with the secrets of nature, they also function to express various feelings and experiences deeply and impressively. Especially, this feature in colours can be observed in the example of traditional symbolic meanings formed in the art of word by them.

Particularly, there are several proverbs in the treasure of meanings of Uzbek nation that the ideas put forward have been typicalized in the images connected with colour. The colours which make symbolism connected with colour in them are, mainly, the lexemes white and black. By means of these contrast colours together with good deeds, purity, happiness, health and high rank, the most

disgusting characters, misfortune, sadness, grief, slander, illness in the society are expressed. For instance, in the proverb “Oqqaqorayo’q, qoragachorayo’q” (No black for the white, no measure for the black) the lexemes white and black are substantivized and risen to the level of symbolic image. The White is the symbolic image of an innocent person, no matter how much he is blamed, anyway, in the consequence he will be found not guilty and stay pure. Because, truth can be bent, folded, but never broken. The black, that is a guilty person will stay guilty anyway, no matter how much he tries to defend himself, there is no way of exonerating him completely, it is impossible. In the proverb “Qorako’ngil—yarako’ngil” (Black soul – ill soul) it is meant that our people hate evil-natured, ill-intentioned, afflicted men, their real face should be revealed and definitely they will be punished for what they have done.

In this case the symbolic image “Black soul” is not very fixed, not inchangeable, because as the wound is treated, that’s as other but death is a lie, the “black” soul is hoped to return to its original state in the consequence of some particular measures. Because, it is obvious to everyone that in this world babies are not born with black souls by their mothers.

As our ancestors lived in the society, they taught us what attitude should be assumed to whom, not to conclude about a person according to his appearance, beauty or ugliness, impressiveness and charm or disabilities or invalidness, and vice versa every one should be respected according to his intelligence, grace and perfection, meaningful and pleasant talks, good works he has done and is doing, reputation in the society and in this sense they created the following proverbs such as “Haryuzioqningko’nglioqbo’lavermasa, haryuziqoraningko’ngliqorabo’lavermas” (Every innocent is not always pure-hearted, every guilty is not always evil-natured), “Qoratuvoq ham oqtuxumqiladi” (A black hen lays a white egg), “Qorabulutdantiniqsuvtomar” (Clear water drops from black clouds), “Qorasigir ham oqsutberadi” (A black cow gives white milk). In the proverb “Erio’libergatekkan el to’rasi, eribo’libergatekkan bet qorasi” (She is noble who got married after her husband’s death, She is the black of the face who got married while having a husband) “the black of the face” expresses the symbol of betrayal to the husband and to the family, the unforgivable and irremovable spot in a woman’s reputation, a wonderful magic of the nature. In this case “black” includes several nuisances such as being dishonorable, being cursed and denounced, even being separated from people, cut of the human relationships with people around. This concept expressing the traditional symbolism is equally familiar to everyone, it can be interpreted in different colours.

In the proverb “Ikkioshiqbirbo’lsa, qo’ymaydibag’riqoralar” (If two beloved are together, the black-hearted people envy them) the black-hearted people are those who envy the lovers, the couples living happily together and also close friends, they are bad people who spread rumours behind them and disseminate disgusting lies and nonsensical slanders about them. The proverb reminds that it is necessary to be careful from such black-hearted people in order not to repeat such situations. In the proverb “Mololasitashida, odamolasiichida” (The pied of cow is outside, the pied of man is inside) the substantivized adjective “pied” consists of the mixture of two colours, it is the symbolic expression of a good or a bad person, that’s of an unknown person with a secret behavior for us. Thus, the colour of an animal is known by appearance but the behavior of people cannot be known by appearance. Because appearance does not define the inner features, “Qoratuvoq ham oqtuxumqiladi” (A black hen lays a white egg) is known to everyone.



Besides white and black, in some cases yellow, red, green are used that they denote the sign of the object in their original meanings, in figurative meanings they carry unique symbolic meanings. For example, the proverb “Ko‘kbedananiko‘rsa, qariot ham o‘ynoqlaydi” (As soon as seeing the green alfalfa, an old horse will dash about) mainly expresses a figurative meaning, the adjective green in it is interpreted as the symbol of youth and beauty.

In the proverb “Onayurtingomonbo‘lsa, rangiro‘yingsomonbo‘lmas” (If your Motherland is in peace, your colour won’t be as yellow as straw) the image straw is the expression of the colour yellow. It is describes that if there is no peace in the country, as a result it is definite that there will be death, finish in life. The straw in the proverb is used as the expression of symbolic meaning of yellow.

In general, many symbolic images in the Uzbek folk proverbs are connected with colours that have expressed traditional symbolic meanings as the conclusion of life experiences for ages.

The complicated spiritual state of a man is seen more clearly by colours. In this case colours are used appropriately to their natural features. These features are of significance by their division into cold and hot. Colours served to emphasize the literary description during the progress of literature as the adjective of a component being expressed at first, later, its function was directed to fulfill a complex compositional function. In Uzbek literature studies in several works the use of colours in poetry was mentioned in general, on the way. Among them the opinions of A.Kayumov, A.Hayitmetov, I.Hakkullof are worth of attention. In Y.Iskhoqov’s monograph named “Poetics of Navoiy”, mainly, figurative characteristics of colours in classical literature, their credal-traditional aspects are more focused on. Sh.Turdimovgave his opinion about the poetic symbol and symbolism of colour in the folk songs depending on the traditional view point.

Colour, first of all, is not a credal concept, but it is a natural phenomenon. According to the feature of this natural phenomenon, human beings used the colour for their socio-ideological and credal purposes, firstly, by learning its natural features. Approaching the colours as a means of symbol and the use of colours in a traditional relationship began.

Symbolic and linguoculturological features of colours have found their reflection not only in the proverbs of folklore, but also in folk songs and song-games (plays) too. For example, The game “White poplar or green poplar”, the festival “Red flower” are among them. The most part of the games were created in the past, their origin was based on the animistic and totemistic, fetishistic different magic imaginations and credal thoughts of our ancestors. It can be noticed from the name of the games or some motives in them. For example, on the base of the game “White poplar or green polar” which was widespread among children there lies mythological thoughts of primitive people about the colours of white and green and their totemistic imaginations related to trees.



“White poplar or green polar” has been living in the repertoire of children for a long time as a game-song. In every work dedicated to the children’s folklore there have given certain opinions about this game. G.Jahongirov tried to have a look at the historical-genetic roots of the game and noted that its origin was influenced by the forms of battles and their rules<sup>11</sup>.

The game “White rice, green rice” which is still played among the children of Khorezm people is worth of attention. This game was developed, mainly, among the people dealing with farming, the meaning indicating good or bad harvest of the rice is emphasized in it. It is noticed that “white rice” denoted white, full, good quality rice, “green rice” denotes sickened, darkened and bad quality rice. In these colours too mythological imaginations of people about the colours of white and green, consequently, in white the symbolic meaning such as happiness, luck and brightness; in green the symbolic meaning of death is reflected.

While analyzing the poetic symbolic language of this game, Sh.Galiyev describes the colours of “white” and “green” according to the seasons. According to the researcher’s opinion, the green is the spring, the time the whole world is covered with green, and the white is the poetic analogue of winter with white snow<sup>12</sup>. In our opinion, the colours of “white” and “green” have kept the first mythological concepts in themselves. That’s, the meaning of keeping the white, good quality rice during the whole winter and plant it again in the spring, and that the low quality rice should be consumed and finished till the spring is leading in the game-song.

It can be seen from this that every traditional children’s games has their own unique history of origin, like other types of art they also passed through the certain historical-literary process. By studying them we can know about the history of long centuries culture of our nation. The games introduce the children with the past and the road of historical development of our nation.

The traditional public festival “Redflower” which is connected with the awakening of the nature in the spring has been a tradition since the ancient times among the Khorezmians. The festival “Red flower” has been held every year in the graveyard Bavorisbobo near Khiva city. All the classes of the population – youth, children, adults could take part in this festival. In folklore the festival of red flower is interpreted as a symbol of love and family. N.M.Lobacheva, who collected the ethnographic materials related to the festival of red flower of Khorezmians, considers this public festival to be “the holiday which finishes the spring festivities and starts the summer ones”. The blossom of red flowers is in May and June. In some places the demonstrations concerning this festival have been held for a month continuously. Giving red flowers or roses to one’s relatives and friends is one of the particular traditions of the holiday.

It can be seen from these examples, in our national culture and mentality the significance of colours is great, in every field of our society they exist. Our task is to realize, feel the colours fully and use them correctly.

It can be said as a conclusion that in the works done on the adjectives of colour, mainly, their semantics and symbolic meanings were greatly focused on. In some works their connotative

meanings were also focused on. But historical semas of the lexeme “green” have not been less focused or not studied at all. If historically studied, many more meanings of the lexeme green can be revealed again.

#### **LIST OF REFERENCES:**

1. AytmatovChingiz, ShokhonovMukhtor. Moaning of the hunter left on the peak.Tashkent -- 2009. p. 28.
2. Alpatov V.M. Language and culture.–M.: Languages of Slavian culture, 2003. – p. 225.
3. VejbitskayaA. Language. Culture. Cognition. –M.: Russian dictionaries. 1996. –p.124.
4. Sodikova M. Words denoting colour in the Uzbek language: Candidate dissertation on philology. – Tashkent, 1963. –p.168.
5. IskhoqovYo. Symbols of colours// Poetics of Navoiy. –Tashkent: Fan, 1983. –p.p. 123-138.
6. HakkulovI. About the interpretation of black colour again // Uzbek language and literature. – Tashkent, 2001. – №3. –p.p.17-20
7. Ma’rufovZ. Adjective // Modern Uzbek language (lexicology, phonetics, graphics and orthography, morphology), Tashkent: editorial board of the Academy of Sciences of Uzbekistan, 1957, p.p 343 – 357.
8. MadrahimovO. About the adjective in and new derived adjectives Uzbek. // Report of the Academy of Sciences of Uzbekistan, series of social sciences, Tashkent, 1957. p.p41 – 47.
9. Epithets in the language of the poetry of Zulfiya // Questions of Uzbek stylistics and speech culture (collection of scientific articles), the works of SamSU, new series, issue 346, Samarkand: 1978, p.p58 – 66.
10. Karimov S. Literary style of the Uzbek language. – Samarkand: Zarafshon, 1992. p.140.
11. National Encyclopedia of Uzbekistan. Tashkent:. State scientific edition, 2003, p.176.
12. National Encyclopedia of Uzbekistan. Tashkent:. State scientific edition, 2003, p.169

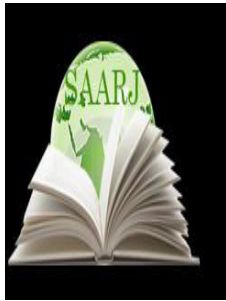

**ACADEMICIA**  
**An International**  
**Multidisciplinary**  
**Research Journal**  
 (Double Blind Refereed & Peer Reviewed Journal)

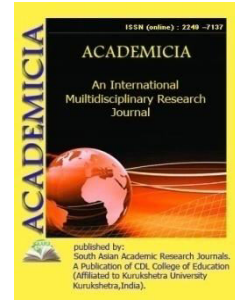

**DOI: 10.5958/2249-7137.2021.01937.6**

**INTERPRETATION OF THE LIVESTOCK TRADITIONS AND  
 CEREMONIES IN ARCHAEOLOGICAL RESEARCHES  
 (ON THE EXAMPLE OF JIZZAKH OASIS)**

**Eshmukhamatov Akhror Sharipovich\***

\*Base doctoral Student,  
 Department of History and Ethnology of the Peoples of Central Asia,  
 Tashkent State University of Oriental Studies,  
 UZBEKISTAN  
 Email id: axrorbek8686@mail.ru

**ABSTRACT**

*This article, based on archeological research of the Jizzakh oasis, describes the views of archaeologists who have studied the graves of cattle breeders of the Jizzakh oasis. The history of animal husbandry in the Jizzakh oasis has been studied more archeologically. These studies were conducted mainly in the archaeological direction, and the materials of the burial mounds were poorly analyzed ethnographically. During the years of independence, a group of scientists discovered and studied the burial mounds of nomadic pastoralists in the Jizzakh oasis. They analyze issues such as the emergence of burial mounds belonging to nomadic pastoralists in the oasis, burial ceremonies, the ethnicity and ethnicity of the owners of the monuments, the emergence and formation of pastoralism in the oasis. Archaeologists who have studied the burial mounds in the Jizzakh oasis have studied the material objects and burials, as well as features of the material and spiritual culture of the ancient pastoral population. At the same time, in the Middle Syrdarya region, including the Jizzakh oasis, there are changes in the quality of raw materials based on local traditions, and there are nomadic features, and sometimes items belonging to the full nomads. The ethnological aspects of the ideas of the peoples of the region, from household items to burial customs, are described in the article.*

**KEYWORDS:** *Avesto, Chordara, Koksuvtepa, Takatash, Suzmoyilota, Nakhrajsay, Shirinsay Cemeteries, Kaplan Ota, Sigomsay, Gulbo, Cattle Breeding, Religion, Shrine, Oasis, Pasture, Shepherd, Herd, Horse, Camel, Cattle, Sheep, Goat, Cult, Ethnolocal Features.*

## INTRODUCTION

There are many reasons why developed nations know and appreciate their history, respect historical monuments, and remains, and preserve them as a unique heritage. This is primarily due to the fact that history is a mirror of the social process that has been going on since the emergence of humanity. Secondly, the whole of humanity, looking at this history, understands their past and existence, determines the plans for the future. The Uzbek people, which has entered the XXI century through modern development, has a rich culture and invaluable spirituality, occupies a special place with its historical past, which has penetrated into the depths of millennia [1: 255].

## MATERIALS AND METHODS

Indeed, archaeological sources testify that animal husbandry was one of the oldest forms of traditional farming and one of the main types of labor that determined the source of livelihood. Speaking of the field, the lifestyle of herders and the views and traditions associated with this training has been studied to some extent by our researchers on the basis of ethnographic materials. However, it should be noted that ancient religious beliefs and beliefs related to animal husbandry have not yet been specifically studied as a separate object of study. After all, since ancient times, that is, since the beginning of the process of capturing and domesticating animals, the rituals and customs associated with animal husbandry have reflected the attitude of the people to the animal world. At the same time, it embodies the relationship between human and nature, human and the animal world, the life experiences of human society over thousands of years of labor, its attitude to space and time, its spiritual views and, of course, the religious beliefs of that time.

It is known that national values were created by our ancestors and polished over the centuries. The livestock sector, its traditions, written sources, and folklore samples are a great achievement of the Uzbek people's contemplation.

The study of the historical basis of animal husbandry in the Jizzakh oasis, which has a special place in the daily life of the people, is one of the most important issues in illuminating the history of Uzbek statehood.

Like other historical regions of Uzbekistan, the Jizzakh oasis is a unique and important micro ethnographic region. The convenient geographical location of the oasis and its location at the crossroads of the Great Silk Road has led to the harmonious formation of very diverse cultures and traditions.

The steppes of the Mirzachul Desert in the oasis and the northern slopes of the Turkestan Mountains are rich in various natural resources for the development of animal husbandry. Therefore, we can surely say that from the earliest stages of human society, the mountain valleys of the oasis were actively assimilated by our ancestors. Remains of nucleus-stone cores measuring 54 x 53 x 21 mm, made of Neanderthals in the Middle Paleolithic period, found in the territory of Chimkurgan collective farm of Forish district of Jizzakh oasis [2: 5], were found in the vicinity of Chordara, Koksuvtepa, and Ettisoy oasis. Examples include pre-Neolithic archeological artifacts from the Neolithic period [3: 51-55], as well as the area around Lake Tuzkan, the western part of the Kalgansir salt flats, and Neolithic flint stone tools and Bronze Age pottery from the Khan-Charvak canyon. These antiquities testify to the fact that this oasis,

like other regions of our country, has a primitive history associated with the first human footprints.

The Jizzakh oasis is located mainly in the Sangzor-Zaamin region, in the central part of the Republic of Uzbekistan, between the valleys of the Syrdarya and Zarafshan rivers. The total land area of the region is 21.1 thousand km<sup>2</sup>, which is 4.5% of the total area of the republic [4: 593]. The region is bordered by Mirzachul range to the north and northeast, Nurata range to the west and northwest, Turkestan, and Morguzar mountains to the south [5: ziyonet.uz]. The mountainous areas of the region include Bakhmal, Zaamin, Forish, Gallaaral, Yangiabad districts, and the mountainous area of Sh. Rashidov district. The total land area of this region is 17.0 thousand km. Perhaps this is why, from ancient times, these vast areas were actively assimilated and developed by our ancestors, who were engaged in animal husbandry. Zaamin, Bakhmal, Gallaorol, and Forish districts are located in the southern, southwestern part of the oasis, between the Turkestan and Nurata mountain ranges, as well as between the Molguzar, Quytash, Gubduntog, Qaraqchitag mountains and on the hillsides. These districts cover 76.7% of the total area of Jizzakh region and 42% of the total population (974.8 thousand people in 2001) [6: 119-120]. The largest villages in the Sangzor-Zaamin region are located mainly in the mountains and foothills, in the Mo'g'ol, Sartyuz, Oyqor, Oqqurg'on, Bog'ishamol, Sangzor valleys, G'ubdun, Ko'kbuloq, Mirzabuloq and other villages in the Gallaaral plain, as well as a number of villages such as G'allakor, Gulshan, Chorvador, Omongeldi, Qizilqum, Qoraobod, Eshbuloq are formed in the form of bands in the foothills of Zaamin and Nurata mountains [7: 36-39]. Such a territorial arrangement of villages allows us to conclude that the population sought to settle around large and small streams and rivers, closer to the water, which is convenient for farming and gardening.

The architectural structures identified in the archeological monuments of the oasis (Nurtepa, Xontepa, Qaliyatepa, etc.): basements, semi-basements and aboveground structures also indicate the beginning of the settlement process of the nomadic population here in the Late Bronze and Early Iron Ages. Naturally, from ancient times the livestock population living in the oasis and the surrounding steppes had a great influence on the process of cultural development in the Jizzakh oasis [8: 72]. This population was first and foremost strongly connected with the vast expanses of Eurasia and the world of nomads living in these vast regions. Seasonally migrating herders traveled to the far northern regions, and in winter returned to their winter quarters, connecting with the agricultural oases of the Jizzakh oasis and even the southern regions. The huge migration processes associated with the socio-political and environmental situation in antiquity accelerated the influx of many nomadic pastoralists into and around the oasis.

According to researchers, in ancient and early Middle Ages, Central Asia was inhabited by Turkic tribes - Sarmatians, Yuezhi, Huns, Usuns, Hephthalites, Xionians, Kidari, Turks and others, whose names differed little from the peoples of the region in terms of language and way of life. Certain groups of them remained in the cattle-friendly areas of the Jizzakh oasis and continued to run their traditional farms. They searched for grassy pastures, mainly in the foothills, valley valleys of Mountain Rivers and streams, in areas not yet developed by local settlers and pastoralists [9: 72-74]. Continuing the tradition of specialized farming, these tribes were engaged not only in pastoralism but also in metallurgy and primitive agriculture.

Archaeologists who have studied the Ustrushona burial mounds say that the material objects and burials have features of the material and spiritual culture of the ancient herdsmen. At the same



time, in the Middle Syrdarya region, including the Jizzakh oasis, there are changes in the quality of raw materials prepared on the basis of local traditions, the characteristics of nomads, and sometimes items belonging to the whole nomads. This can be seen in all areas of the country, from household items to funeral rites. Admittedly, pastoralism plays a key role in the livestock economy of the oasis.

Consequently, the southern and western parts of the territory of the Jizzakh oasis consist of mountainous and foothill regions, which are very convenient for the livelihood of hunter-gatherer and nomadic pastoral peoples. In this respect, these areas are rich in many archeological monuments inherited from our ancient hunter-gatherer and nomadic pastoral ancestors. The fact that our archeologists have been engaged in animal husbandry since ancient times is also confirmed by the rock carvings left by them.

As a result of field archeological research conducted by our scientists, more than 1,000 galleries of rock carvings have been studied on the northern slopes of Morguzar Mountain, from the location of Takatosh in the Saikhansay ravine. They belong to several epochs, the oldest of which dates back to the Neolithic and Bronze Ages, and the latter to antiquity and the Middle Ages[10: 22]. The rock paintings here depict hunting scenes, many wild and domestic animals, the performance of religious ceremonies, and more. Rare examples of this primitive and ancient art testify to the fact that the livestock sector in the Jizzakh oasis has ancient roots.

Archaeologists have identified Suzmoyilota rocks in the mountains and hills north of Jilli-Gulli village of Sharof Rashidov district, Nakhrajsay (Kattasay) gorge of Nakhraj village of Gallaorol district, Yukorisay (Soyibolo) ravine from Eski Forish village of Forish district many new rock art monuments from large streams and ravines have been registered and put into scientific circulation[11: 54-57]. While the wild animals depicted in these rock paintings are species of animals that lived in the mountains and foothills in ancient and modern times, domestic animals are among the animals that have been domesticated by humans for a long time.

This type of wild animal can include primitive bull, primitive cow, mountain goat, argali, gazelle, saiga, original deer, wild horse, pendant, wild boar, as well as wild animals such as lion, tiger, cheetah, leopard, wolf, fox, jackal and others. . Images of snakes and birds can sometimes be seen on the rocks[12: 77].From them, it is known that since ancient times the oasis has become a fertile and convenient pasture for the cattle-breeding population. conditions were present.This is because, in ancient times, large woods, reedbeds, and semi-deserts were located in the Nurata mountain range, or the Kyzylkum desert was adjacent to this ridge, so there were favorable conditions for their living. These true factors are also proved by the wonderful images of our ancient ancestors reflected in the rocks.

It should be noted that in recent years, archeological excavations in the Jizzakh oasis have been studying a lot of information related to animal husbandry. It is well known that in nomadic pastoral tribes the notion that "people will live in the world" after death is widespread. Based on these perceptions, the rituals of observing the deceased in the afterlife include the burial of the deceased, the household items he used in his life, clothing, weapons, ornaments, and the custom of placing various dishes in his dishes for consumption in the afterlife[13: 46]. Such tombs were called tombs and it was found that they belonged mainly to nomadic herdsmen. Such tombs will contain items related to the profession of the deceased. These burial booms are an important source in the ethnographic study of the history of animal husbandry.



In the second grave in the Shirinsay cemetery, studied by archaeologist-researcher V.F. Gaydukevich, two corpses - a woman and a child - were buried. Near the head of the body was found a ceramic bowl, a disc-shaped buckle around the waist, on the left side were pieces of a knife and a 6.7 cm long stone, and in front of the pelvis were sheep bones [14: 337]. Researcher Sheep bones were placed in the middle of the head of two bodies in the grave in Gulbo cemetery of Zaamin district, studied by F.E.Toshbaev[15: 43-45].

Fragments of a sheep's skull were found next to objects in the Saganak cemetery, studied by A.A. Gritsina, who had been studying the oasis for many years[16: 78].

In the tomb of 28 in Shirinsay, studied by V.F. Gaydukevich, in the tombs of Bekkeldi and Qamish, studied by FE Toshbaev, ceramic palms with the image of a sheep (lamb) on the handle were studied. Leading archeologist of the oasis M.H. Paradaev also studied livestock-related materials at the Paradaqultepa and Komilbobotepa monuments located in the territory of Jizzakh. The monuments include statues of rams with twisted horns and about 10 pot bases with the symbol of a sheep's head. M.H. Paradaev, who made an in-depth scientific analysis of the essence of these findings, notes that they are "connected with nomadic pastoral peoples"[17: 42-43].

It was also noted by M.H Paradaev that his archeological researches presented the sheep's skull buried on the top of the ewer grave in the Yoyilma mahalla of the district Sharaf Rashidov[18: 261]. M.H. Paradaev states and evaluates the findings as: "Worship of the sheep belief is not only in the spiritual culture of other regions, but also in the myths of the Turkic peoples associated with totemism. In fact, in the last quarter of the first BC, the "Melon Culture" was formed in the middle reaches of the Syrdarya and had a strong influence on the neighboring agricultural oases. "During the various Turkic dynasties (Yue-Chi, Huns, Hephthalites, and the Turkish Khanate) that ruled Central Asia before the Arab conquest, views on sheep-herding were also widespread within this broad influence" [18: 262].

The fact that cattle-breeding is one of the most ancient occupations of the people of the oasis is also reflected in the religious and spiritual life of our ancestors. The zoomorphic pottery in the pottery, the pot bases with the image of a ram, the sheep bones in the tombs and tombs, and the sheep-shaped images on other objects show that the sheep cult was much stronger in the oasis. Sources say that in ancient times, the Kanguys, who also controlled the Jizzakh oasis, worshiped the Zoroastrian god Farn[19: 6]. This god, the goddess Farn, was accepted as a sheep. The sheep bones found in the tombs, its symbol, or the images of sheep in pottery vessels indicate that sheep-breeding had a high status in the oasis cattle-breeding farm, and was considered a symbol of abundance and blessing. Another reason for the frequent occurrence of sheep-related ceremonies is that in the hot steppe climate, small (ushok) cattle (sheep, goats) made up the majority of the population, and in this connection the sheep cult was much stronger.

The Qochqor ota shrine in North Ustrushna (Zaamin), one of the most sacred shrines of our people today, or the Kaplan ota shrine on the opposite side of the mountain, and the huge ram's horns hanging from a tree, show that the idea of deifying the ram still exists among the population[20: 48]. As in other parts of our ancient land, among the inhabitants of the Jizzakh oasis, the custom of hanging ram's horns (skulls of sheep or other animals) in cemeteries, shrines and even houses is still preserved. There is a common understanding among all the villagers about the function of these horns and heads, according to which these horns protect the place and

its inhabitants from the evil eye and various calamities[21: Field records. Abdulla a gravedigger. 1949 Shurcha village of Zaamin district].

In the tombs 1, 2, 4 of the Gulbo cemetery, studied by F.E. Toshbaev, who is conducting in-depth scientific research on the archeology of the oasis, the bodies of our ancestors look like horses on horseback or in the form of a horseman The custom of burial was studied in[22: 23-26]. The researcher describes the fact that the body of the deceased, buried in the 2nd tomb of the Gulbo monument, with all the weapons, was buried in the form of a "half-horseman" (sitting on one side of the horse, "sitting in a Kazakh"), a sign that he spent most of his life on horseback. and concludes that they are related to the occupations and horse-worshipers of the period of the lives of the deceased[22: 24]. Sources testify that the cavalryman, who at one time was engaged in cattle-breeding, was not only skilled and brave himself, but at the same time their horses were extremely warlike.

In the rocks of Suzmoyilota, Nakhraj and Sig'omsay, studied by the researcher A.Kholmatov, there are many images of horsemen, which are considered important in the life of steppe nomadic peoples. They are drawn when riding a horse or a camel[23: 14]. In particular, the riders are depicted in a variety of views, designed in a realistic, semi-realistic, and schematic way. The cavalry is depicted by artists on a saddled horse and with or without a saddle in their hands, only in the form of a saddle in their hands. In some cases they are depicted on horseback without saddles and bridles. So, for the people of the oasis, horse breeding was also one of the ancient branches of animal husbandry.

It is also important to us that the image of a primitive bull (bull) is among the images of the Suzmoyilota rock. The image of a wild bull was carved by an ancient master painter in realistic and semi-realistic views, with a large head, long horns, short neck, shoulder (shoulder), long waist, slender body, and the tip of the tail is fluffy. The surface of these paintings was scorched by sunlight and darkened like the original surface of the stone. This proves to us that it is one of the oldest images among the Suzmoyilota rock paintings[23: 15].Also, according to some zoomorphologists, such as wild bulls (primitive bulls) were destroyed on the eve of the first millennium.

Given that the ancient artists realistically depicted the animals they saw and the landscapes in which they participated, it is clear that such wild bulls lived in the Bronze Age in the Jizzakh oasis.

As a continuation of our comments, we can add that ethnographic data show that cattle have been kept on the farms of every family for a long time. In each house there is a separate place for them as a symbol of fertility. The owners of the "Melon Culture", including the Ustrushans, also had a tradition of worshiping the ox (black cattle) mentioned in the famous Indian epic Mahobharata[24: 16]. The deification of cattle and oxen has existed in ancient times, and it is also reflected in the image of "Gopatshah". The human bull is a bull with a human body and a face with a human face[25: 133-141]. The term "gopatshah" is a three-component word, the first two components of which are "gao-pati" in the Avesto - "the ruler of the cattle", and the third, in a much later Pahlavi suffix, means "king", "king".

It should be noted that the number of cattle on the farm of Ustrushona was not so large. This is also primarily related to the problem of forage collection for large numbers of cattle. The image of Gopatshah, which has existed since ancient times, plays an important role in the views on the

cattle (bull) cult, and it is traditionally associated with large horned animals. By antiquity, the image of the patron and guardian animal was mixed with the cult of the ox, which provided water for crops and crops[25: 140]. The ox cult is valued as a patron of abundance and rainfall. According to the researcher A.Khojaev, in ancient Chinese sources the terms "nguzie", "ruzie" were used as a state name. However, these terms are derived from the word "oguz" or "guz". The word "Oghuz" in modern Uzbek means a divine bull, which was used in the past as a symbol of strength and power, and was a totem of the people of the state of Ruzie[26: 21].

In the monuments of the "Melon Culture" in the Jizzakh oasis, the image of a bull is associated with a hearth. In this case, the ox (cattle) is compared to the god of the house, who protects the family from various calamities and shortcomings. In many cases, a bull-horn-like home stove was specially installed and left a small hole in it for the feeding of the patron spirit. Most of the bases of the furnaces are represented in the form of "Gaopatshah" and his female form. Opinions about the bull cult (though not named) have survived to the present day.

According to ethnographer Adhamjon Ashirov, "In Andijan, if there was a drought and no rain, animals were slaughtered in cemeteries or various animals (oxen, sheep, rams) were sacrificed to the river when the Syrdarya flooded until the 1970s." [27: 82].

In the cases we are considering, we see the opposite. The sacrifice made by the people with the intention of rain and abundance of water, and in the dervishes, the bull is mainly slaughtered for the purpose of "abundance of fruit and abundance." If we look at the number of livestock in the mountainous and foothill areas of Ustrushna, the majority of animals are still small animals - sheep, goats, then cattle or yearlings.

According to art historian L.I. Rempel, the legendary first bull was associated with floods, from whose bodies came medicinal and spice plants, and from its seeds all useful animals [28: 22]. In general, the traditional connection of the ox with the flood was vividly reflected in the ancient religions of the eastern peoples[29: 32]. We can also find the connection of the bull cult with water in later traditions. In particular, the Uzbeks of Andijan slaughtered cattle in the graves if there was a drought and no rain[30: 170].

If we ethnographically analyze the burial customs in the cemeteries studied in the Jizzakh oasis, it is common to bury the body with animal bones next to it. Thus, in the oasis herdsman, the observation of a deceased relative in the "other world" includes the burial of objects related to his profession, animals that played an important role in his life and were later deified, or some of their limbs (sometimes symbols) and sacrificial animals. also widespread. The burial of animals in graves or sacrifices is associated with animistic and totemistic imagery. While animistic notions were based on the idea that living beings have a soul and would not disappear even after the death of its owner, nature-cosmic spirits and powerful gods rule over beings, totemistic beliefs believed in the divine qualities of that animal to save man from various calamities.

## RESULT AND DISCUSSION

The bones and burial rites of animals such as sheep, goats, horses, cattle, dogs, and wolves recorded in cemeteries in the Jizzakh oasis testify to the strong totemistic views of various animals among the peoples living in the region. if) a simple pet - the divine cross-section associated with the taka is widespread. The deification of the mountain goat has existed since ancient times, and it is shown in the researches of B.A. Litvinsky that it is widespread in the Sak

tribes[31: 144-149]. According to the primitive notions that have survived among our people, the evil demon appears in the form of a goat. Various real-life stories about him still occur today as a continuation of ancient divine imaginations[32: Field records: Abdurakhim Sulaymonov is 68 years old. Lives in Turkestan SFU, Arnasay district, Jizzakh region].

It is also noteworthy that in the monuments studied in Ustrushna, dog bones were recorded near the body, on the thresholds, or in pottery vessels. This fact shows that this animal was considered sacred and that the notions associated with the dog totem in folk customs have been widespread since ancient times. From ancient times the dog was considered to have an incomparable devotion to mankind, divine power. In this regard, rituals associated with the deification of the dog are common not only in the traditions of the breeder, but also in the settled population. The burial customs of Ustrushna associated with the sanctification of the dog have been studied by a number of our archaeologists.

For example, the jawbone of a dog (or wolf) was placed in a three-legged vessel in the 14th tomb in the Shirinsay cemetery, where scientific research was conducted by VF Gaidukevich. In the Gulbo 2 cemetery, studied by researcher Tashbaev, dog bones were placed on the head of a western male warrior. The tomb of Khojai Serob I also contains a dog's tubular bone, lower jaw bone and two teeth. Dog bones, first dried in the sun and then buried in the sand, were found near the monument in Khantepa (Khavas district of Syrdarya region) [33: 27]. During the excavation of a trench 150 m away from the monument on the southern slope of the Turtkultobatepa monument in the village of Boshpishogor, Zaamin district, Jizzakh region, a dog's skull and a small inverted palm were found inside [34: 77]. Such data, studied in the Jizzakh oasis, encourage a broader analysis of dog-related rituals. The burial of a dog with a deceased person has been known since the middle of I BC. These customs can be explained by the religious commandment in the Avesto, which states that after the death of a dog, his status is equal to that of a human being. The above-mentioned archeological finds works of art and animal-related ceremonies found among our people testify to the fact that livestock breeding has been widespread in the Jizzakh oasis since ancient times. It means that on the basis of them our ancestors have been respecting and breeding cattle since ancient times.

## CONCLUSION

The conclusion is that archeological excavations, the burial customs associated with livestock studied in cemeteries provide valuable information about the social, political, material, and spiritual life and lifestyle of the people of the ancient Jizzakh oasis. The occurrence of animal-related rituals at the funerals listed above is a testament to the fact that the pastoralists paid special attention to the livestock on their farms. You can also directly witness the various traditions associated with the economic life of the population of animals buried in the grave with their bodies or their symbolic representation.

## REFERENCES

1. Eshov B.J., Odilov A.A. History of Uzbekistan. T.: "Yangi asr avlodi", 2014. –P. 255.
2. Sayfullaev B.K. Paleolithic of the valley of the Zerafshan River and the northeastern Kyzylkum desert (technical - typological study). Aftoref. Cand. ist. Sciences, Samarkand, 2003. P. 5.
3. Anarboev I.A. Drevnosti Golodnoy stepi. // IMKU №4. –T.: 1963.-S. 51-55.

4. National Encyclopedia of Uzbekistan. Volume III. —Uzbekistan National Encyclopedia. State Publishing House. -T.: -P. 593;
5. Haydarova S.A. Features of development of villages of mountainous areas of Jizzakh region. // [www.ziyonet.uz](http://www.ziyonet.uz).
6. Tojiev Z., Astanaqulov Z., Asqarxo'jaev R. Some problems in the geodemographic situation of mountainous and foothill districts of Jizzakh region. // Geographical bases of use of mountain and foothill areas (Materials of the scientific-practical conference). –T.: 2002. – P.119-120;
7. Bobobekov A.D. Influence of natural conditions and ethnoecological factors on the ethnic-economy of the population of mountain and foothill regions. // Problems of history and archeology of Central Asia (Materials of the Republican scientific conference). Part 1 Samarkand. 2018 –P. 36-39.
8. Pardaev M.Kh. To the question of the evolution of the planning of rabat castles in North-West Ustrushan // Tez, reports of scientific conference. dedicated to the 80th anniversary of Acad. Ya.G. Gulyamova. -T.: 1988. -P.72.
9. Toshboev F.E. Reflections of ancient migrations in the burial ceremonies of the people of Ustrushna. // “Tafakkur ziyosi”, №3. Jizzax, 2019. -P. 72-74.
10. Khuzhanazarov M. Rock carvings of North - East Uzbekistan. // Author. diss. Cand. hist. sciences. L., 1985 .-P. 22
11. Kholmatov A.N. Nurata mountain rock paintings. Doctor of Philosophy (PhD) dissertation in historical sciences. T.: 2019. -P. 54-57.
12. Kholmatov A.N., Pardaev M.H., Toshboev F.E. Preliminary results of the study of Suzmoyilota rock paintings // Archaeological research in Uzbekistan. Samarkand, 2018. –P. 77.
13. Toshbaev F.E. On the construction of Ustrushona tombs and their formation.//Archeology of Uzbekistan. №1 (18). 2019. -P. 46
14. Gaidukevich V.F. Burial ground near Shirinsay in Uzbekistan // SA. –M.: 1952. - №26. -P. 337.
15. Toshboev F.E. Ustrushona breeders' religious views on domestic animals. // “Tafakkur ziyosi”. Scientific-methodical journal of Jizzakh State Pedagogical Institute. Jizzax, 2018. – P. 43-45.
16. Gritsina A.A. Study of burial mounds in the Syrdarya region // IMKU-Samarkand: 1997. - №.28, - P. 78.
17. Pardaev M.H. On the interdependence of the worship of the spirit of the sheep and the wolf // O'IF (ONU). - T.: Fan, 1995. – № 1-2- 3. –P. 42-43.
18. Pardaev M.H., G'ofurov J.I. The first medieval rural sites of Ustrushna (based on written and archeological sources). Tashkent, 2016. -P. 261.
19. Litvinsky B.A. Kangyui-Sarmatian farn. Dushanbe, 1968. –S. 6.

20. Akchaev F.Sh. The sacred sites and shrines of the Jizzakh oasis (ethnosociological research) (PhD) dissertation thesis. T.: 2020.-P. 48.
21. Field records. Abdulla a gravedigger. 1949 Shurcha village of Zaamin district.
22. Toshboev F.E. Traditions associated with horses as an ancient value of the Uzbek people.// SamSU Bulletin of Scientific Research № 6 (52) Samarkand, 2008. –P. 23-24-26.
23. Kholmatov AN, Khojanazarov M. New rock paintings of Jizzakh oasis. // Jizzakh oasis - in the system of Central Asian civilization (from ancient times to the present). Proceedings of the Republican scientific-practical conference. Jizzax, 2020. -P.14-15.
24. Filanovich M.M. Ancient and medieval history of Tashkent in archaeological sources T.: 2010. - P. 16.
25. Bogomolov G.I. The image of Gopatshah in Chacha // IMKU No. 36. T.: 2008. - P. 133-141.
26. Khodjaev A. From the history of the ancient Turks (information from ancient Chinese sources) T.: 2010 - P.21.
27. Ashirov A.A. Mythological views and traditions of the population of the Fergana Valley related to water // History of Uzbekistan. № 1. 2018. - P. 82.
28. Rempel L.I. Chain of Times: Age-old images and wandering plots. 1987. - P. 22.
29. Andrianov B. Bull and snake (At the origins of the cult of fertility) // Science and religion. - 1972.- No. 1.-p. 32.
30. A.Ashirov. Ancient religious beliefs of the Uzbek people in the traditional way of life. (Based on the materials of the Fergana Valley). Dissertation for the degree of Doctor of Historical Sciences. T.: - 2008. –B. 170.
31. Litvinsky B.A. Ancient nomads "Roofs of the World". M.: GRVL. 1972. - P. 144-149.
32. Field records: Abdurakhim Sulaymonov is 68 years old. Lives in Turkestan SFU, Arnasay district, Jizzakh region.
33. Pardaev M.H. Report on the archaeological study of monuments of the history of material culture in the irrigation and land development zone of the Kizilinsky massiv for 1985-1987 ... - p. 27.
34. Mamirov O.U. Zoological worship of the people of Ustrushna in the early Middle Ages (based on archeological and ethnological materials). "Jizzakh oasis - in the system of Central Asian civilization (from ancient times to the present)." Jizzax, 2020. -P. 77.



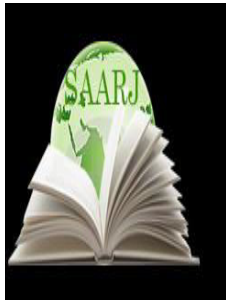

**ACADEMICIA**  
**An International**  
**Multidisciplinary**  
**Research Journal**  
 (Double Blind Refereed & Peer Reviewed Journal)

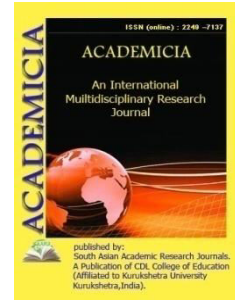

**DOI: 10.5958/2249-7137.2021.01938.8**

## ON SOME WAYS TO PREPARE STUDENTS FOR PROFESSIONAL ACTIVITY IN TECHNICAL HIGHER EDUCATION INSTITUTIONS

**Adizova Sevara Yusupovna\***

\*Senior Lecturer of "Mechanical Engineering Technology",  
 Bukhara Institute of Engineering and Technology,  
 UZBEKISTAN  
 Email id: sevara.adizova@mail.ru,

### ABSTRACT

*This article theoretically illustrates the specific ways and opportunities to improve the preparation of students for professional activity in the development of innovative cooperation between education and science, industry, their interaction and integration. At the same time, it was noted that the successful implementation of education on the basis of innovative cooperation can lead to the training of highly qualified specialists who can meet modern requirements.*

**KEYWORDS:** *Innovation, Professional Activity, Integration, Professional Education, Organic Connection, Production, Innovative Cooperation.*

### INTRODUCTION

The rapid development of technical spheres, production, service and management infrastructure in the world requires the training of specialists capable of using innovative equipment in high-tech enterprises. Advances in science, engineering and technology serve to radically improve the quality of life of people, while at the same time creating social, economic, cultural, material and other conditions for their vital activities, while realizing their personal needs and interests. Mobile communication, personal computers, personal appliances and all kinds of service equipment, modern information and communication are based on the scientific and technological progress of mankind, and today in the space of technical change, artificial living environment is becoming more efficient than the natural environment.

In the context of scientific approaches to the formation of a global educational environment specific to European countries, Megatendence shows that ensuring continuity and practical orientation of education, focusing on independent learning and creative development, vocational

education ensuring integration between theory and practice plays an important role in active development.

With general and specialized disciplines according to international experience

deepening the interconnectedness of production structures has a positive impact on the effectiveness of education. It is also important to further expand the integrative organizational function of education, modernize forms and methods of education, the formation of personal and professional qualities, ensuring the harmony and continuity of elements of innovative professional potential in the further development of trends in vocational education theory (technical higher education institutions) and practice (high-tech enterprises). processes play an important role. This requires the examination of the results of professional training of vocational education specialists and employees of industrial enterprises on the basis of an integrated education system, taking into account the principles of membership and interdependence, and the development of appropriate methodological recommendations on identified problems.

Systematic reforms are being carried out in our country to shape the integration of science and industry. The Action Strategy for the Further Development of the Republic of Uzbekistan provides for a holistic and systematic approach to ensuring the implementation of priorities such as "development of mechanisms for assessing the quality of education, improving the availability and efficiency of educational services" and "large-scale training and retraining." the formation of integrative knowledge, professional skills and competencies, and diagnostic assessment of learning outcomes play an important role. In this regard, it is necessary to study the state of professional training of vocational education specialists and production workers, to study their professional competence in their specialties and areas of production, to develop and implement innovative methods of pedagogical diagnosis.

### **The main part**

The mutual partnership of technical higher education institutions and technological manufacturing enterprises leads to the formation of innovative entrepreneurial skills by personnel in theory and practice.

This approach to the organization of the educational process is successfully used in foreign countries (Russia, Germany, France, China, etc.) and is called practice-oriented education, because, as mentioned above, the interaction of the education system with industry - the knowledge acquired by students in vocational education, the results of the assessment in the production of the requirements for skills and competencies. It should be noted that the main factor in the learning process is the practice, that is, training in a particular workplace of the enterprise and the production of a particular product (for example: for the lathe profession - workplace - machine, and the result of the work the removal of a particular detail).

For successful implementation of innovative cooperation it is necessary to solve the following:

- modernization of the educational process in vocational education;
- introduction of a modular education system;
- Improving the professional competence of teachers and coaches in enterprises;
- Strengthening the motivation of students.

Modernization means equipping vocational education institutions with modern teaching equipment, introduction of innovative teaching technologies and educational resources, professional competence of teachers, first of all, information and communication technology (ICT) literacy and in-depth knowledge of their subject, as well as experience and leadership of high-tech enterprises. specialists will be selected and focused on vocational training. Excursions to enterprises, organizations, educational and social institutions will be held as part of the social partnership and dual education training.

Students get acquainted with the staff and working hours of organizations, working conditions, meet with leading specialists of enterprises.

Innovative collaboration for students creates opportunities for early independence and easy adaptation to adulthood. Innovative education provides easy access to professional activities without the inevitable stress for other forms of learning due to lack of information and lack of practical training. It not only allows you to learn to perform specific job tasks, but also develops the ability to work in a team, forming professional competence and responsibility. Innovative education provides great opportunities to manage a student's career. Under it, the level of education is constantly increasing. No education can provide information about production as innovative education, which is one of the important steps on the path to its successful development.

Higher education institutions train specialists based on the prospects of development of modern high-tech enterprises in mechanical engineering. Strengthens the theoretical knowledge acquired by students on the basis of innovative cooperation in the same enterprises. Based on the interest of talented students in the industry, innovative cooperation groups are formed in each area. During the academic semester, this group of students conducts internships, internships, course work and course projects, graduate work in the enterprises attached to them, as defined in the curriculum. At the same time, they can get acquainted with the formation of innovative projects on topics of interest, the implementation and commercialization of the developed developments, and participate in the implementation of this project in collaboration with the leader of the innovation group.

Management of the infrastructure of this innovative cooperation is carried out through coordinating scientific and technical councils consisting of representatives of relevant government agencies, higher education institutions and enterprises. The Coordinating Council analyzes new developments created as a result of innovative cooperation over the period and the purpose of innovative projects planned for future implementation, the identified measures for the implementation of tasks, expected results, the provision of specialists and funding stages. In addition, research centers, financial institutions and foreign participants, experts and researchers can be involved in the implementation of large innovative cooperation projects. Foreign participants, industry experts and researchers can participate with their lectures and practical seminars. This will not only increase the effectiveness of professional training of future potential personnel, but also create a great basis for the exchange of experience of employees of these enterprises.

## **CONCLUSION**

It can also be concluded that training future professionals in independent research, independent problem solving, creative approach to it, as well as the acquisition of knowledge, skills and

---

competencies in the production process based on the unity of theory and practice. Today, the process of training active, inquisitive, intellectual, managerial, professionally cultured, competitive, creative-minded professionals is one of the main tasks of the continuing education system. has scientific and practical significance.

#### REFERENCES

1. Kustov Yu.A. Continuity of vocational - technical and higher education. - Sverdlovsk: Publishing house of the Ural University., 1990.
2. Fedorets G.F. Integration problems in the theory and practice of teaching (Development paths). - L., 1990.
3. Begimkulov U.Sh. "Informatization of pedagogical education: theory and internship", Monography, Tashkent. Fan, 2011, pp. 1-232.
4. Nuridinov B.S., Urinov U.A. "Social cooperation in the field of education, a factor of training qualified personnel", Journal of vocational education, vol. 6, no. 1, pp. 11-16, 2003. ISSN: 2010-7498.
5. SaidovaX.X. "Innovative forms of education in Uzbekistan", International journal of innovations in engineering research and technology [IJIERT] Volume 7, ISSUE 4, Apr.-2020, Pages: 258-261.

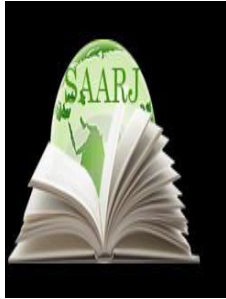

**ACADEMICIA**  
**An International**  
**Multidisciplinary**  
**Research Journal**  
 (Double Blind Refereed & Peer Reviewed Journal)

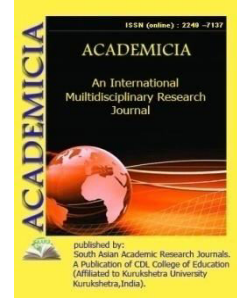

**DOI: 10.5958/2249-7137.2021.01939.X**

## RECOMMENDATION AND FOR THE IMPLEMENTATION OF INNOVATION IN CONSTRUCTION

**Djabriev Akbarali Normurodovich\*; Karimov Inomjon Ortikbaevich\*\***

\* Professor,  
 Doctor of Economic Sciences,  
 Chair "Economics and management of real estate",  
 Tashkentskiy architectural and construction institute,  
 UZBEKISTAN

\*\* Senior Teacher,  
 Chair "Economics and management of real estate",  
 Tashkentskiy architectural and construction institute,  
 UZBEKISTAN

### ABSTRACT

*The article provides the result of a study on the creation of a mechanism for sustainable innovative development of construction and their implementation, followed by their lonely efficiency. The combination of some works of the preparation stage and the implementation stage is also possible, if it does not interfere with the development. We believe that the innovative potential is not only the potential for the creation, formation and implementation of innovations and innovations, but also the readiness to accept these innovations by enterprises for their subsequent effective use. In the construction industry, when analyzing the transition for certain types of work as a whole, the change in labor intensity and cost can be determined depending on the change in the duration of construction.*

**KEYWORDS:** *Innovative Activity, Innovative Development, Cluster Approach, Construction Complex.*

### INTRODUCTION

The intensification of innovative activity in the construction of Uzbekistan is an objective necessity, which is dictated by the modern needs of modernization of the national economy and the urgent tasks of more fully meeting the social needs of society. The analysis shows that the innovative development of an industry or a region in modern conditions is ensured through the

use of cluster formations, which over the past decades have found widespread development in many developed countries.

The analysis showed that the innovative development of the construction industry is not conducted systematically enough, often does not provide the required response to modern challenges, on the one hand, and the industry itself, its existing potential (the presence of many small enterprises, their insufficiently developed material and technical base), on the other parties, require the formation of an industry innovation cluster based on the following principles:

- hierarchical structure of the cluster;
- sequential implementation of cluster formation processes, guided by the rule "from simple to complex";
- take into account the stages of the life cycle of clusters, start forming a cluster of the initial (first stage);
- the transition from one stage to the next should be carried out if all levels of the cluster meet the requirements of this stage;
- consolidation of actions at all levels of the cluster is provided by various methods of influence (from administrative to economic, including the incentive system);
- all actions for the formation and development of the cluster are carried out taking into account the need to achieve sustainable innovative development and obtain a synergistic effect.

## LITERATURE REVIEW

The innovative potential of a construction organization is a specific indicator that characterizes the organization's ability to carry out innovative activities.

In a number of studies, the category of innovation potential is interpreted as a set of resources [1, 7, 9, 2] in others [3, 4], innovation potential is understood as a set of material and mechanical, personnel and information resources.

In [8], the concept of innovative potential is formulated as a set of resources for the production of innovations, including material, financial and intellectual resources.

In [5,6], the term under consideration is interpreted as a measure of an enterprise's readiness to perform tasks to achieve an innovative goal.

We believe that the definition of innovation potential as an existing set of resources does not fully reflect the essence of this concept, since the presence of the same resources in different conditions of their use cannot guarantee the receipt of equivalent results. We believe that the innovative potential is not only the potential for the creation, formation and implementation of innovations and innovations, but also the readiness to accept these innovations by enterprises for their subsequent effective use.

Based on this, we highlight the following main characteristics of the innovative potential:

- A set of resources. Which the company possesses and can use them to organize innovative activities;



- The ability to carry out innovative activities at the enterprise;
- Willingness to carry out innovative activities at the enterprise;
- The ability to carry out innovative activities at the enterprise.

The methodology for the implementation of innovations in construction is recommended to be produced according to the vision and consistently in the field of implementation of work on innovative development. It is proposed to smooth this process in four stages.

**TABLE 1 STAGES OF IMPLEMENTATION OF WORK ON INNOVATIVE DEVELOPMENT IN CONSTRUCTION**

Stages of work	Stage name
Stage I	Scientific and design development, including experimental testing
Stage II	Organizational and technical (technological) preparation for implementation
Stage III	Mastering the first samples and mass introduction
Stage IV	Summing up and analyzing the results

Briefly, the stages can be designated as development, preparation, implementation and analysis.

The first stage takes place mainly in the field of science and design development, and the subsequent three - in the field of production. On the other hand, preparation for implementation can begin at the stage of research and development. The combination of some works of the preparation stage and the implementation stage is also possible, if it does not interfere with the development. Moreover, the sequential-parallel organization of the innovation process makes it possible to accelerate and increase its efficiency and is one of the factors in achieving a competitive advantage. The last three stages, carried out in the field of production, relate directly to the organization of the introduction of innovation.

Since the stage itself and its constituent parts are an important section of organizing the implementation of innovation, in the future we will continue to consider in detail each of them separately and in interconnection.

The organization of the introduction of new technology cannot be carried out without analyzing the observations and summing up the results of the implementation. In this sense, this stage is final.

These indicators, in addition, give an idea of the ratio of costs and benefits of the introduction of new technology and are a tool for analysis.

In construction, it is proposed to use three groups of indicators. The first is generalizing indicators of the impact of innovative development on the economic efficiency of construction. Among them: growth in labor productivity, growth in profits and reduction in construction time, growth in product quality, etc. In the second group, it is recommended to use the share of innovation in the total volume of products and thus determine the level of innovative development in the main areas. The third group of indicators is the physical volume of implementation in physical terms.

The fourth group is the most important, responsible and decisive, this is the stage of direct development (materialization) of innovation. To a certain extent, this is the crown of the entire multi-stage process of creating and introducing innovations.

The essence of the development process is determined by the type of new technology being mastered. The development of a new prefabricated building structure consists in mastering technological processes, labor methods and in developing skills for the manufacture, transportation and installation of this new structure. At the same time, a new technology for the manufacture, transportation and installation of structures is often created and mastered. New equipment, rigging, transport and assembly means are created and also mastered for this.

In the technological sense, development is reduced to restructuring, readjustment, the transition to the creation of new products, the use of new actual costs at this time have already changed. In essence, the above actual data is used to determine the costs, which is disseminated by the calculation to the entire implementation process. The indicated costs can therefore be called actually calculated.

After analyzing the technical continuity and dynamics of the need for innovation in construction projects, it is possible to determine the methods of transition. Transition methods are the basis for the development of specific detailed organizational and technical measures aimed at the widespread development of innovation.

First of all, it should be borne in mind that the enterprise, in comparison with the activities for the production of conventional products, incurs additional one-time costs already in preparation for the implementation of the innovation. These costs are associated with research, design and development work, preparation for implementation, with the reconstruction and renewal of fixed assets, changes in the composition of working capital, training, etc.

In the construction industry, when analyzing the transition for certain types of work as a whole, the change in labor intensity and cost can be determined depending on the change in the duration of construction. In this case, a well-known technique is used to determine the effect or losses from changes in the duration of construction. The relative cost and labor intensity proportional to the duration of construction and, *ceteris paribus*, stabilizes with the stabilization of the duration of construction.

These costs are caused by the need for preparation of production, restructuring and readjustment of technology and organization of production and labor methods. In turn, this causes a change in the volume and structure of fixed and circulating assets.

The final stage of the introduction of innovation is to summarize and analyze the results of the development of new technology. In this case, the following issues are subject to consideration:

1. Scope of implementation of measures for the implementation of innovation.
2. Obtaining the given technical, technological and economic parameters of the introduced innovation. Determination of the causes of deviations, if any.
3. The actual, total and specific cost of the introduced innovation or the cost of its implementation.
4. Actual economic efficiency of the implemented innovation.

5. Comparison of expected and obtained results.
6. Deciding on the prospect of further use of innovation.

Of course, the list of issues that are clarified during the summing up and analysis is not limited to this.

To summarize and analyze the implementation results, intermediate results obtained in the implementation process are also used.

At all stages of creating and organizing the implementation of innovations, one of the main issues is economic efficiency. Methods for its determination are widely developed and presented in special literature.

The annual economic effect is the total savings, which is expressed in the increase in net present value (profit) due to the saving of production resources as a result of the introduction of new technology.

When calculating the annual economic effect, in a number of cases, the time factor is taken into account by bringing to the beginning of the billing year the one-time and current costs for the creation and implementation of new and basic equipment, as well as the results of their application.

The main task of management is to ensure the continuous growth of economic efficiency based on the activation of innovation and ensuring the effective implementation of innovations.

Management of innovation implementation is part of the functions and processes of management of innovation development, which is an integrated, unified and end-to-end process, from scientific development and design to implementation.

Organization of any kind of permanent activity, solution of long-term tasks, and achievement of new goals are possible only on the basis of systematic work. Moreover, a systematic approach is needed when organizing monitoring of the implementation of innovations in construction.

## CONCLUSIONS

As a result of the research carried out on the preparation of recommendations for innovations in construction, the main subcodes were studied in determining the innovative potential of construction development, namely:

- scientific and flight development;
  - Organizational and technological training;
  - mastering innovations and mass adoption;
  - summarizing and analyzing the results, it is recommended to consider the following issues:
    1. The volume of implemented innovations;
    2. Obtaining the specified parameters. If there are deviations, establishing their cause;
    3. The cost or costs of introducing an innovation;
    4. Cost-effectiveness of innovation;
    5. Decision on further use.
-

**REFERENCES**

1. Twiss B. Management of scientific and technical innovations. J. Economics. 1989 271s.
2. Fatkhutdinov R.A. Innovation management. Peter. 2005 448 s. 39. Makhkamova M.A. Theory of innovative management. Monograph. Tashkent 2019
3. Mazur N.Z. innovative economy innovative systems. Intellectual Property / Samara Publishing House of the SSC RAS. 2011 r.
4. Drucker P. Innovation and entrepreneurs: Practice and principles. Drucker JnT Pan Books, 1986, p.55
5. Zainutdinov Sh.N. Strategy for the Development of Innovative Solidarity.// Scientific Electronic Journal of Economics and Innovative Technologies. №1.2011
6. Zainutdinov Sh.N. Nurimbetov R.I. Methodology for creating economic industrial zones in the region. Bulletin of Science and Practice / Scientific journal / Nizhnevartovsk, Russia, 2017, 211-215s.
7. Urmarov I., Saidkarimova S., Oblakulov Sh. Analysis of indicators of innovative potential of industrial enterprises. Economy and innovative technologies. Scientific electronic journal. №July 4-August 2015.
8. Otazhanov Sh.I. Improving the efficiency of organizational economic mechanisms for managing the information structure of innovation activity. Abstract. Tashkent 2018. 10s.
9. K.I. Ortikbaevich. Attracting investment projects to the construction industry and improving their efficiency. 2021. SAARJ Journal on Banking & Insurance Research 10 (1), 47-53
10. N Yusupdjanova, I Karimov. Investment projects in the field of construction materials production..2020. Theoretical & Applied Science, 18-21

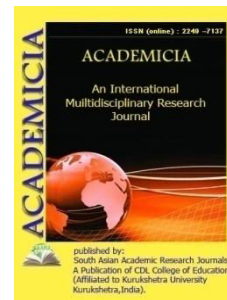
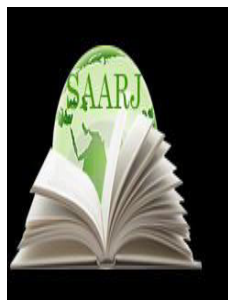

DOI: **10.5958/2249-7137.2021.01940.6**

## STANDARDIZATION OF SUBSTANCE BASED ON GINKGO BILOBA

**Hulkar Tuygunovna Zairova\***; **Farhod Khakimovich Tukhtaev\*\***;  
**Nozima Saidova Sadikova\*\*\***

\*Associate Professor,  
Tashkent Pharmaceutical Institute,  
UZBEKISTAN  
Email id: hulkarzairova @ gmail.com

\*\*Associate Professor,  
Tashkent Pharmaceutical Institute,  
UZBEKISTAN

\*\*\*Assistant,  
Tashkent Pharmaceutical Institute,  
UZBEKISTAN

### ABSTRACT

*The substance is standardized in according to requirements of the European Pharmacopoeia (EP) for such an indicator as authenticity, loss in mass upon drying, sulfate ash, residual solvents and quantitative content of the sum of flavonoids (flavono glycosides).*

**KEYWORDS:** *Gibkgo Biloba, European Pharmacopoeia, Identification, Assay, Total Flavonoids (Flavone Glycosides), Quercetin, Campferol, Isoramnetinetin, TLC And HPLC.*

### INTRODUCTION

At present, one of the urgent problems of the modern pharmaceutical industry is the search for domestic biologically active compounds and the production of domestic drugs on their basis. One of these representatives is the leaves of the Ginkgo biloba trees (Ginkgo biloba).

For the development of domestic pharmacy and the expansion of the range of drugs based on local standardized substance, we carried out a study on the development of technology for a standardized, enriched dry extract of ginkgo biloba growing in the territory of Uzbekistan.

Ginkgo biloba leaf extract has a complex chemical composition; it includes more than 40 biologically active ingredients. A standardized extract from the leaves of Ginkgo biloba contains

three main groups of substances that determine its specific pharmacological activity and are indicators of the authenticity of raw materials: Flavonic glycosides, terpene lactones and ginkgolic acids [1]. Flavone glycosides have a wide range of effects: antioxidant, antiatherosclerotic and neurotransmitter effects. Terpene lactones (ginkgolides and bilobalide) are found only in the leaves of ginkgo biloba biloba, they have antioxidant activity, in addition, they inhibit the platelet activating factor and have anti-ischemic activity [2]. An important indicator of the quality of raw materials is the ratio of the flavone glycosides of kaempferol, quercetin and isorhamnetin. According to the provisions of the Pharmacopoeia of Europe and the United States, the total content of flavone glycosides in the extract should be in the range of 22-27% [3].

Quercetin is a flavonoid of the flavonol class, which has decongestant, antispasmodic, antihistamine, anti-inflammatory and diuretic effects; has antiviral and antitumor properties. It is included in the group of vitamin P. Quercetin is the most active of the flavonoids, has a pronounced antioxidant effect.

Kaempferol is a flavonoid of the flavonol class; it strengthens the walls of the vessels of the microvasculature and removes toxins from the body. This biologically active substance has a pronounced restorative, anti-inflammatory and tonic effect, it is also a diuretic.

Isorhamnetin (3-methylquercetin) is a flavonoid of the flavonol class, a metabolite of quercetin. Less well studied compared to quercetin. In terms of pharmacological action, isorhamnetin is similar to quercetin and kaempferol. As an antioxidant, it protects the phospholipid membranes of brain cells from damage, prevents thrombus formation, strengthens the vascular wall, has the activity of vitamin P, is able to inhibit phosphodiesterase and hyaluronidase, protects adrenaline from oxidation and prevents the destruction of ascorbic acid.

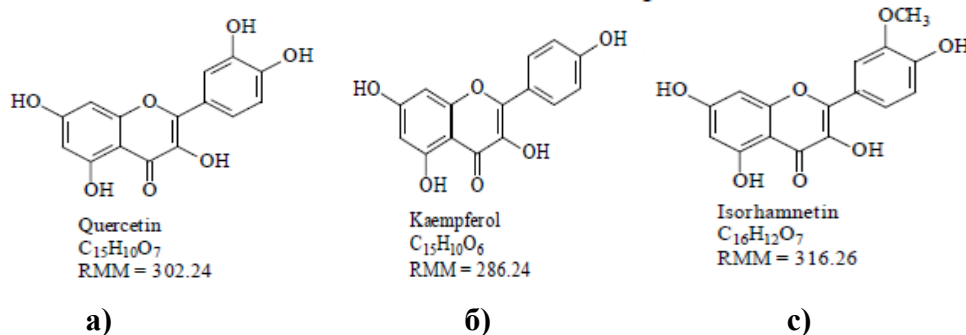

### Rice. 1. Structural formulas of quercetin (a), kaempferol (b) and isorhamnetin (c)

The most popular preparations of ginkgo biloba extract are: tablets "Tanakan", "Memoplant", "Bilobil", "Ginos", "Ginkoum", "Vitrum memory" and are among the five best-selling [4]. The use of ginkgo preparations enhances concentration, increases energy, reduces distraction, relieves fatigue, depression, nervous conditions, headaches. The aging process of the body slows down, physical activity and efficiency increase.

The aim of the study is to standardize the obtained dry extract of ginkgo biloba growing in the territory of Uzbekistan.

Materials and methods. The following methods were used to standardize dry ginkgo biloba extract: TLC and HPLC



**Experimental part**

The object of the research is dry extract of ginkgo biloba leaves. (Ginkgo biloba).

Description.

The dry extract is characterized as a fine, light yellow brown powder.

Authenticity.

TLC (BP / EP 2.2.27).

Test solution: About 20 mg of the extract is dissolved in 10 ml of a mixture consisting of 2 ml of purified water and 8 ml of methanol.

Reference solution: Dissolve 1.0 mg chlorogenic acid and 3.0 mg rutin in 20 ml methanol.

**Chromatography condition:**

Plate: TLC silica gel (5-40  $\mu\text{m}$ ) or (2-10  $\mu\text{m}$ )

Mobile phase: Anhydrous formic acid, glacial acetic acid, purified water, ethyl acetate (7.5: 7.5: 17.5: 67.5).

Application: 20  $\mu\text{l}$  (or 5  $\mu\text{l}$ ).

Development: run length 17 cm (or 6 cm).

Drying: at a temperature of 100-105  $^{\circ}\text{C}$

Definition: The plate is initially sprayed with a 1% solution of diphenylboronic acid aminoethyl ester in methanol, and then with a 5% solution of macrogol 400 in methanol. The plate is air-dried for 30 min, viewed under UV light at 365 nm.

Results: The sequences of the zones in the chromatograms of the obtained reference solution and the test solution are shown below. Other areas of fluorescence can also be detected and can be detected on the chromatogram of the test solution.

Front plate	
	Blue fluorescent area
	Several light colored areas
-----	-----
	Brown fluorescent area
	Green fluorescent area
	Intense light blue fluorescent area, sometimes overlapping with a greenish brown fluorescent area
Chlorogenic acid: blue fluorescent zone	
	One or two green fluorescent zones
Rutin: yellowish brown fluorescent zone	One or two yellowish brown fluorescent areas

-----	-----
	Several green and yellowish brown fluorescent areas
Reference solution	Test solution

### *Quantitation.*

*Flavonoids (flavone glycosides): 22.0% to 27.0% (dry extract). Метод ВЭЖХ (BP/EP 2.2.29.)*

Test solution: 200.0 mg (so-called) extract is placed in a 100 ml volumetric flask. Add 20 ml of methanol and dissolve in an ultrasonic bath for 1 min. Add 15.0 ml of dilute hydrochloric acid (7.3%), 5 ml of purified water and 10 ml of methanol. Heat the flask in a water bath at 90 ° for 1 h 35 min. Up to 15 minutes before the end, 20 ml of methanol are added. After the end of heating, allow to cool and put on an ultrasonic bath for 3 minutes.

The resulting solution is transferred into a volumetric flask with a volume of 50 ml, rinsing the flask with methanol and the volume of the solution is brought to the mark with methanol, mixed and filtered through a Millipore filter with a pore size of 0.45 µm, discarding the first portions of the filtrate.

Quercetin dihydrate standard solution (CRS): 10.0 mg (so-called) quercetin dihydrate (CRS) is placed in a 50 ml volumetric flask and dissolved in 20 ml methanol. Add 15.0 ml of dilute hydrochloric acid (7.3%) and 5 ml of purified water and bring the volume of the solution to the mark with methanol, mix and filter through a Millipore filter with a pore size of 0.45 µm, discarding the first portions of the filtrate.

### **Chromatography conditions:**

Mobile phase A: Adjust the pH of 1000 ml of purified water to pH 2.0 ± 0.05 with concentrated phosphoric acid.

Mobile phase B: Methanol.

Column: 125 x 4.0 mm, packed with octadecylsilyl C-18 sorbent, particle size 5.0 µm or similar.

Flow rate: 1.0 ml / min;

Detection: 370 nm;

Column temperature: 25 ° C;

Analysis time: 25 min;

Injection volume: 10  $\mu$ L.

Note! Post time: 3 min.

Time	Mobile phase A	Mobile phase B
0	60	40
1	60	40
15	45	55
24	0	100
25	0	100

*Quercetin retention time: about 12.5 minutes,*

*Relative retention time of kaempferol: about 1.4; isoramnetin: about 1.5.*

*Suitability of the chromatographic system: test solution:*

*- The separation between the peaks of kaempferol and isorhamnetin should be at least 1.5.*

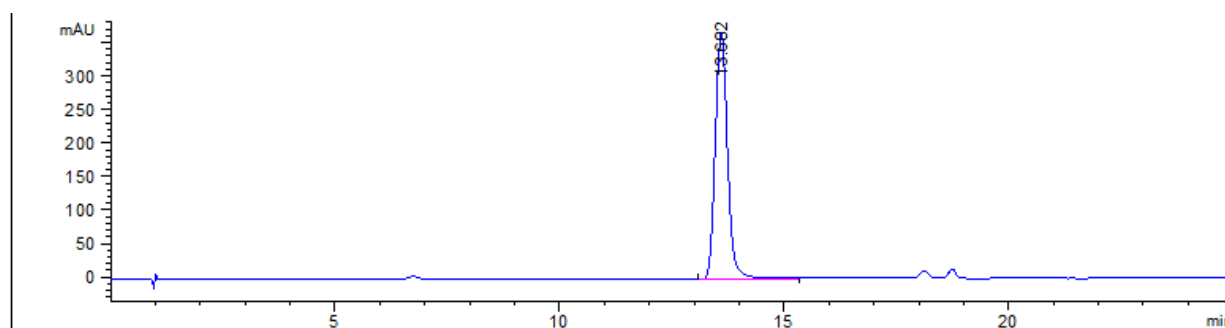

a)

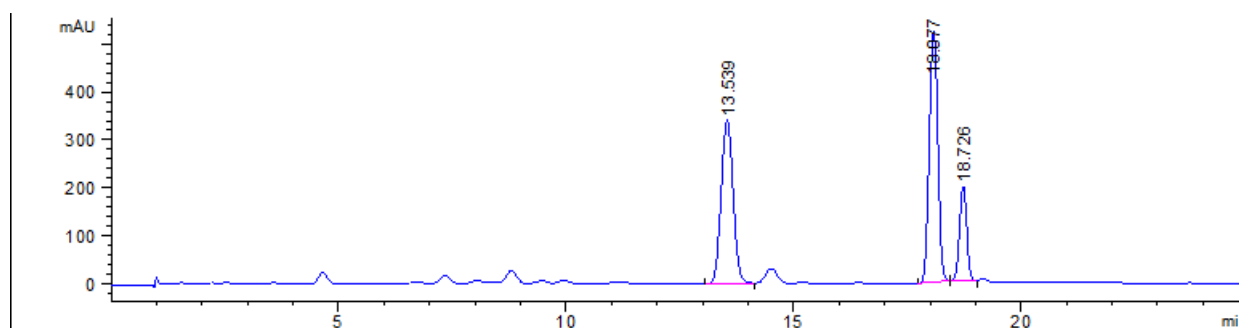

b)

**Rice. 2. Chromatograms from HPLC: a) chromatogram of the standard (quercetin),  
b) chromatogram of the sample (ginkgo biloba).**

The content of the sum of flavonoids (X), in%, in terms of flavone glycosides is calculated by the formula

$$X = \left( \frac{S_1 + S_2 + S_3}{S_{st}} \cdot m_{st} \cdot 50 \cdot 2.514 \cdot P \right) / (S_{st} \cdot m_1 \cdot 50) = \left( \frac{S_1 + S_2 + S_3}{S_{st}} \cdot m_{st} \cdot 2.514 \cdot P \right) / (S_{st} \cdot m_1)$$

where,

S1 is the area of the quercetin peak calculated from the chromatograms of the test solution;

S2 is the area of the peak of kaempferol calculated from the chromatograms of the test solution;

S3 is the isorhamnetin peak area calculated from the chromatograms of the test solution;

Sst is the peak area of quercetin calculated from the chromatograms of the standard solution;

mst is the weight of the quercetin dihydrate (CRS) sample, in mg;

m1 is the mass of the sample of the extract, in mg;

P - the actual content of anhydrous quercetin in the standard sample, in%;

2.514 is a coefficient associated with the average molecular weight of flavone glycosides.

Note. Preparation of 7.3% hydrochloric acid: 17 ml of concentrated hydrochloric acid is placed in a volumetric flask with a volume of 100 ml containing a small amount of purified water, stirred, the volume of the solution is brought to the mark with purified water and stirred.

The obtained chromatograms of the analysis of the quantitative content of dry extract of ginkgo biloba in Fig. 2.

The obtained results of the analysis of the quality of dry extract of ginkgo biloba are shown in table 1.

**TABLE 1 RESULTS OF QUALITATIVE ANALYSIS OF DRY EXTRACT OF GINKGO BILOBA**

Indicators	Limits	Methods	results
Description	Fine, light yellow brown powder.	Visually	Fine, light yellow brown powder.
Идентификация	ТСХ. На хроматограмме испытуемого раствора должны обнаруживаться следующие зоны: верхняя зона – синяя флуоресценции, коричневой флуоресценции, средняя зона – светло-голубой или overlapping with greenish-brown fluorescence and lower zone - rutin: one or two yellowish-brown fluorescences.	ТСХ (BP/EP 2.2.27).	On the chromatogram of the test solution, the following zones were found: the upper zone - blue fluorescence, brown fluorescence, the middle zone - or overlapping with greenish-brown fluorescence and the lower zone - rutin: two yellowish-brown fluorescences.
Quantitative	HPLC method	(BP/EP	24,63%

content	Flavonoids (flavone glycosides): from 22.0% to 27.0% (dry extract).	2.2.29).	
---------	--	----------	--

All materials and reagents used in the work are manufactured by Merck.

## CONCLUSIONS

1. For the first time, the substance of dry extract of ginkgo biloba (ginkgo biloba) was standardized in accordance with the requirements of the European Pharmacopoeia (EF) for the content of the sum of flavonoids (flavone glycosides) growing in the territory of Uzbekistan.
2. For the first time, new methods of quantitative analysis of the amount of flavonoids (flavone glycosides) of dry extract of ginkgo biloba (ginkgo biloba) growing in the territory of Uzbekistan have been carried out.

The work was carried out jointly by FE OOO "Nobel Pharmsanoat".

## REFERENCES

1. OV Yatsevich Candidate of Pharmaceutical Sciences, Production Director of Tuscany Laboratory LLC, Moscow. Article ginkgo biloba Mesozoic relic - "silver apricot"
2. Kuznetsova S.M., Shulzhenko D.V. State Institution "Institute of Gerontology named after DF Chebotarev National Academy of Medical Sciences of Ukraine "Kiev. "Ginkgo biloba extract in a strategy for the treatment of chronic vascular diseases of the brain. No. 2 (72), 2015 p-111.
3. European Pharmacopoeia, ginkgo dry extract, refined and quantified, 04/2008: 1827
4. Onbysh T.E. Makarova L.M. Pogorely V.E. Scientific journal Modern high technologies. Issue of the journal No. 5 for 2005. Mechanisms for the implementation of the pharmacological activity of ginkgo biloba extract

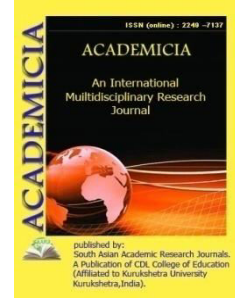

DOI: **10.5958/2249-7137.2021.01941.8**

## SCIENTIFIC STYLE OF NAVOI LANGUAGE

**Berdak Yusuf\***

\*Senior Researcher at the institute,  
Candidate of philological sciences,  
Uzbek language, literature and folklore of the Russian Academy of Sciences,  
UZBEKISTAN

### ABSTRACT

*The article analyzes Alisher Navoi's work "Mezonul-avzon" in terms of scientific methods and terms, and tries to prove the ancient existence of scientific methods in the Uzbek language. In general, scientific works were written in Arabic both before and during Navoi. Under the influence of this tradition, Arabic terms were taken from the donor language ready in the first scientific works in Turkish. Of course, in the written literature, different styles of language appeared much more advanced, but all the same in this way all the variations of the style in all its spheres related to the language do not end. During the Shura period, many linguists claim that this method was not before the October Revolution in Turkic languages, it appeared only after October [1,12].*

**KEYWORD:** *Scientific Style, Term, Text, Word, Lexicon.*

### INTRODUCTION

There are different views on the emergence of a scientific style in the Uzbek language, in general Turkic languages, contradicting each other. During the Shura period, many linguists claim that this method was not before the October Revolution in Turkic languages, it appeared only after October [1,12]. Whereas, the presence of a scientific style in the language of VIII-X century Turkic written monuments E.The R. Tenishev showed in his article [2,180].

It should also be noted that in some works on linguistics published in the Center during the period of the Soviets, an idea was made about the styles of artistic, scientific, publicistic, official works, in Tatar, Uzbek, Azerbaijani, Uighur languages with the inscription "these styles existed in part even before" [3,63], among other styles, it was recognized that the scientific style existed in ancient times. Also about the fact that all styles are available e.G. Tumanyan writes: "It is known that a number of ancient records in the USSR, for example, Armenian, Georgian,



Lithuanian, Estonian and other languages, had an advanced system of styles"[4,48]. The discovery of the work "Fununul-balogha" at the end of the last century was a great event in the history of our culture. Sheikh Ahmad Tarazi's work on the science of this age was written in the old Uzbek literary language in 1436-1437.

The A. About this work hayitmetov says: "Fununul-balogha" is the first perfect guide to the theoretical issues of literature in the Uzbek language, as well as a work of poetic Tazkira character " [5,70].

When the author of a work sometimes wants to explain a term, he first gives its lexical meaning, then its meaning as a term. For example, "The dictionary of Tarse says to set up jewelry made of gold and silver. And the weight corresponds to it, and the word is in one voice, and the last letter in one voice. "[6,78].

Before writing this work, Sheikh Ahmad gets acquainted with the works written in Arabic and Persian on this subject. Due to the fact that such a work was not yet written in Uzbek at that time, Persian, Arabic words and isofas are often found in the explanation of terms: the example is similar to the other. Also, in addition to the Uzbek examples, which are presented after the interpretation of any term, sometimes Persian and Arabic examples from the Qur'an are given in the works of representatives of Persian literature.

"Fununul-Balog'a " studied J. About this written monument " this booklet is the first scientific work created in the Turkic language. Because another work created in the Turkic language on a branch of science is not known to science until today"[7,33], - he says. It's hard to agree with the idea, of course. Because in the Turkic language, more precisely in the ancient Uighur language, works on medicine and astronomy were written[8,69]. Therefore, it will be correct to say that "Fununul-balogha " is the first scientific work written not in the Turkic language, but in the Uzbek language. He studied this work from the point of view of Literary Studies a. Hayitmetov's opinion that "he is the first scientific work in the Uzbek language " [9,24] is very relevant. From the foregoing, it becomes clear that the Turkish language, including the Uzbek language, including the scientific style, did not appear after the October Revolution. Its appearance dates back to the distant past. The e.I. Ubryatova writes about this: "I think the term " style " is used in a very narrow sense. Of course, in the written literature, different styles of language appeared much more advanced, but all the same in this way all the variations of the style in all its spheres related to the language do not end.

Whether a language is spoken or written, whether it has recently been written, or it has been written from ancient times, the concept of "style" is inherent in any language. Apparently, this is typical of a very ancient period of language development"[10.307].

Now we are thinking about the scientific style of the work "Mezon ul-avzon" by Navoi. Depending on the historical development of the language, the concept of style changes. Alisher Navoi understands the type when it comes to style. He puts Nazm above prose.

The name he coined in the science of words,

He did his style in two parts.

If he wants to do a great person,

One is mansur erur, one is manzum.

Nasru nazmi angaki mudrakdur,

The stem of the poem is longer (Sab'ai Sayyar, X-35) [11.93].

The beginning of the use of aruz in the Middle Ages, as a result of the development of the literature of the Turkic peoples, including Uzbek literature, necessitated the writing of works on this weight in the Uzbek language. At the end of the pamphlet, the poet explains why he wrote Mezonul-avzon: "Gharaz is an article and its purpose is an introduction, because the Turkish language is a poetic verse, it has no authority and no knowledge, and there are no books or pamphlets in the field of aruz for the development of science." [12,94]. Continuing after that, Huseyn Boyt made Devon in the weight of aruz, which increased the rank of the poem, Arab and Persian poet scientists wrote books about aruz science, but not one such book was written in the Turkic language, so he wrote this work as follows: "This cell was in the time, the king of the Times, Devon ordered, the blessed memories were preoccupied with the poem vaznig and Beth takte'ig, in this respect the stem of the Turkish poem passed through the Persian poem, and the career of the Bethlehem ate the Bethlehem. Every month, the emancipated emancipates of gentleness, but also the Knights of the evil mind of the evil mind will see this Sharif ilmga ishtig'ol and buhur and avzoni and takte'i and zihofoti and davoyiri ilmidinki Arab fusahasi and Ajam bulag'ovu shuarasi ul ilmda categorize the books that without the moment this FANG'a vukufi and can not be conscious, it is not in the sight of the Munga multafit, by the time it was present in the beginning of the book, was the cause of this interpretation and classification, for this reason, this knowledge officer was penned" [13,61].

When Navoi writes about the poet and scientist Darvesh Mansur in the work "Majolisun-nafois", he says that "I studied Faqir aruz under Darvesh" and learned his aruz science from him. Navoi glorifies aruz as "aruz Fanni Sharif fandur" [14,13], writes that the founder of this science is Khalil Ibn Ahmad. As you know, aruz is a complex and extremely capricious science. Therefore, he studied carefully the SARS of Ibn Hajib (XIII century) "Ilmul-aruz", Rashididdin Vatvot (XII century) "me'yorul-ash'or", written in Arabic and Persian about the knowledge of aruz (aruz) of previous scholars. But Navoi remembers this work in the book "Mukhtasar", which was written in Uzbek in the first half of the 15th century and dedicated a large part to aruz, cites examples from the poems of Ahmad Taraziy [15,69].

It should be noted that such works as "Muhabbatname" of Khorezmi (Khorezm, 1353), "Gulistan bit-Turkic" of Sayfi Palace (Egypt, 1390-1391), "Devon" of Hofiz Khorezmi, written elsewhere than Khorezm, are also not mentioned in the works of Navoi. Kemal Eraslan, who carried out the critical publication of Navoi's work "Mezonul-avzon", argues that he was Navoi "who wrote the first Turkish treatise on Aruz ghaq" [16,5]. Apparently, K.Eraslan was also unaware of the work "Fununul-balogha". Navoi's "Mezonul-ul avzon" IDA is the dictionary meaning of the term aruz, eight solim TAF'ila, zihof and far, formed from these TAF'ilas, circles in which the Bahrs are located, poem takte'i, Bahr weights are in place. Also, about the types of poems written in Navoi aruz, such as tuyug, song, Chinga, muhabbatnama, Turkic, will be discussed in detail. At the end of the work, aruziy notes that he wrote this book about important and honorable Science in order to ensure that there are no works in the Turkic language.

Each scientific field has its own terminological structure with hundreds and thousands of terms. Navoi's "Mezonul-avzon" is a work written in a scientific style. The peculiarity of the style of this work is that it contains many special terms. These terms served to express complex concepts

related to the theory of aruz. These terms, most of which are of Arabic origin, are: alif (ME-30), avtod (ME-14), avzon (ME-14), akhrab (XVI-48), anosir (ME-11), orzuvoiy (ME-60), aruz (ME-33), aruziy (ME-15), afo'il (ME-30), asl (ME-30), aslam (XVI-51), asram (ME-53), atf (XVI-60), atf vovi (ME-31), ahtam (ME-16), arkon (ME-15), aslam (ME-20), asram (ME-20), ashtar (XVI-65), avzon (ME-13), azall (ME-16), batar (ME-16), bahr (XVI-52), bahri basit (ME-57), bahri muqtadab (ME-48), bahri muzore' (ME-46), bahri mujtass (ME-49), bahri munsareh (ME-44), bahri mushokil (ME-52), bahri mutadorik (ME-54), bahri mutaqorib (ME-53), bahri rajaz (ME-41), bahri ramal (ME-43), bahri sare' (ME-50), bahri tavil (ME-57), bahri vofir (ME-57), batar (ME-15), byte (XVI-59), bina (XVI-52), bihor (XVI-52), buhur (ME-12), jahv (XVI-49), jabb (ME-16), jad' (ME-19), juzv (XVI-48), jadid (ME-53), chinga (XVI-92), doira (XVI-84), doirai mukhtalifa (ME-23), doirai mutalifa (ME-22), doirai mujtami'a (ME-26), doirai mukhtalita (ME-58), doirai mushtabiha (XVI-59), doirai muttafiqa (ME-24), doirai muntazia (XVI-55), darb (ME-33), dapur baho (ME-91), dubaytiy (ME-36), abtar (ME-20), ajabb (ME-16), ajzo (ME-24), advor (ME-60), afoil (XVI-59), fossil (ME-13), fossil kubro (ME-14), fosilai sugro (ME-24), fan (XVI-45), far' (XVI-48), fatha (ME-30), furu' (XVI-48), xabl (ME-18), xabn (ME-16), movement (ME-32), hazarai ahram (ME-37), harb (ME-15), kharm (ME-15), hashv (ME-33), hazf (ME-19), hazz (ME-18), hamza (ME-30), hatm (ME-16), huruf (ME-30), humosiy (ME-20), humosiyot (ME-24), ibtido (ME-33), ishbo (ME-30), iskon (ME-17), isqot (ME-17), isola (ME-18), qarib (ME-26), qasr (ME-19), qat' (ME-17), kaff (ME-16), kabz (ME-15), kasir ul-vuqu' (XVI-47), kasra (ME-30), kashf (ME-19), song (ME-58), mahbul (ME-19), mahbuli muzol (ME-18), prisoner (ME-18), prisoner (ME-17), prisoner of war (ME-17), prisoner of war (ME-19), prisoner of war (ME-19), prisoner of war (ME-19), maxbuni musabbagh (ME-17), max muraffal (ME-18), mahbuni muzol (ME-18), mahzuf (ME-17), matviyi makshuf (ME-19), matviyi mavquf (ME-19), matviyi muraffal (ME-18), matviyi muzol (ME-18), majhufi musabbagh (ME-17), majdu' (ME-19), makfuf (ME-17), makshuf (ME-19), manhur (ME-19), marfu' (ME-18), mavquf (ME-19), mavzun (ME-15), misra' (XVI-56), muxalla' (ME-50), majhufi musabbagh (ME-17), maktui musabbagh (ME-17), mahbuni musabbagh (ME-17), muraffal (ME-18), musamman (ME-26), mustahdas mushas (ME-17), mushokil (ME-26), mushokili makfuf (ME-25), mushabbad (ME-30), mushaddas (ME-30), motaharrik (ME-14), muzol (ME-18), nahr (ME-19), nomavzun (ME-13), ozan (ME-60), ozmaq (ME-60), rab' (ME-17), raf' (ME-19), rakz ul-hayl (XVI-87), ramal (ME-20), rubai (XVI-66), sadr (ME-33), sokin (ME-14), solim (ME-33), savt un-noqus (XVI-87), cause (ME-13), cause light (ME-13), cause saql (ME-14), salm I (ME-20), salm II (ME-19), sarm (ME-19), suboiy (ME-20), suboiyot (XVI-52), shatar (ME-16), form (ME-16), tahliy (XVI-49), taqte (ME-30), tavil (ME-20), tayy (ME-17), tarona (ME-36), tarfil (ME-18), tasbig (ME-17), tafo'il (ME-115), tash'is (ME-17), turkiy (XVI-94), tuyug (XVI-91), argushtak (XVI-58), usul (ME-58), usul (XVI-88), waqf (ME-19), vatad (XVI-49), vatadi kompleks' (XVI-50), vatadi mafruq (ME-15), weight (ME-12), zamma (ME-30), zalal (ME-16), zihof (ME-15), zihofot (ME-16).

Apparently, the terms that are inherent in the aruz theory presented, as already mentioned above, mainly refer to the Arabic language. In general, part of the terms used by Navoi in all spheres is Arabic and Persian. Therefore, it is not true that some scholars say that "most of the terms used by Alisher Navoi are Uzbek in terms of their origin"[137]. The reason for many meetings of foreign words in the works of the poet is that Navoi wrote all his works, including Mezonul-avzon, in a high style. At that time, the high style was due to the use of a lot of Arabic, Persian words and terms. In general, scientific works were written in Arabic both before and during

Navoi. Under the influence of this tradition, Arabic terms were taken from the donor language ready in the first scientific works in Turkish. These special terms give the text a stylistic coloring: However, it should be noted that in the science of aruz, the building of the method of poetry is divided into three pillars, which are called "cause" and "vatad" and "fossil" (ME-13); The total poetry of the Arab and non-Arab councils is a complex social one, and the people of Aruz say that it is afo'ilu tafo'il. And he is the owner of eight originals (ME-15); Munsarihi and muzare' and muqtazib and mujtass and sari 'and jadid and old and light and difficult building subo'iyotqadur, at the moment there is disagreement, they do not gather their health in one frame (ME-23); "Harm" is the isqat of the "mim" of the mafu'il, until the fo'ilun is left and the maf'ulun is replaced (ME-15). The scientific terms related to aruz sometimes consist of isophagous compounds. Mushokili musammani makfufi maqbuz (ME-157); Mutaqoribi musammani mahzufi aruzu darb (ME-159); But the munsarihi matvi and muzare'i makfuf and muqtadabi matvi and mujtassi mahbunki, musamman ul-ajzadur, put in a circle and call the circle different (ME-23); And sare'i matviy and jadidi mahbun and qaribi makfuf and hafifi mahbun and mushkili makfuf are musaddas ul-ajzod (ME-25).

Due to the abundance of terms, the style of scientific literature acquires bookishness, complexity. One of the main levels of the scientific style is "logical coherence is reflected in the logical connection of thought with each other in the plural application of nouns and terms, in the coherent description, in the multiplicity of repetition, in the fact that repetition is the norm for scientific speech"[17].

If we compare the colloquial terms of the XV-XVI centuries with the colloquial terms of the VIII-IX centuries with the colloquial terms of the written monuments of astronomy, we can see that the terms assimilated in the XV-XVI centuries constitute the majority. Because by this period, the influence of Arabic and Persian on the Turkic language and Uzbek language was great. Azerbaijani scientist V about it. Aslanov writes: "usually Arabic and Persian lexicons account for 80-90% of the total lexical composition of poetic works in almost all medieval Turkic written sources (including Sakkokiy, ATOI, Navoi, Ahmad Doy, Sheikh Roth, baqiy, Nasimi, Kishwari, Fuzuli and others).). Poets who follow the Arabic-Persian poetic tradition typical of the medieval Turkish language train used poetic templates, which are characteristic of the medieval Persian train "tumultuous, stereotyped expressions" [19,56].

In addition to terminological vocabulary, there is also a general vocabulary concept about scientific methods in the scientific literature. "General words are close to terminological lexicon in terms of the meaning of scientific concepts, differ from terminological lexicon, they are not limited to a single topic, but are widely used in the scientific literature of all disciplines" [20,46]. The following general words are found in the mesonul-avzon: method (ME-11), table (ME-11), science (ME-61), method (ME-58), science (ME-12), rule (ME-12), qavoid (ME-12). The blessed memories of Sultanus-salotin, as at the beginning of the book, were muntafit, which led to the definition and classification, and for this reason the pen of this scientist was written in pencil (ME-61); Every month, gentle princes, but also wise princes, are interested in this noble knowledge ..... (ME-61); But, of course, my dream is the criterion of poetry, the noble science, why the rank of the science of poetry is so high (ME-12); So I am convinced that the science of dreams is a noble science. And there are various reasons why he calls this science "aruz" (ME-13).

In "mezonul-avzon", some universal lexical can sometimes acquire a terminological meaning, losing its universality in the scientific style. For example, in the works of Navoi, "Turkic "as a general-language word means" typical for Turkic languages". But in the following text, having lost the feature of universality, it has acquired a terminological meaning: and again surudedurkim, ANI say "Turkic". (Me-60) such examples can be cited a lot from the work of Navoi "Nasoyimul-love". In this game, most of the terms of mysticism were previously related to the all-encompassing lexicon.

the word in	the meaning of	terms	the meaning of
but,	but, joint	But	desire for
ourselves	astana	ourselves	to tak
debilitating	grief, bitterness,	sorrow	divine ishq
jonon	love	jonon	Allah
junun	madness	junun	if it is true lovers of crazy, like crazy contours
knowledge	knowledge, knowledge	knowledge of the	irfon, enlightenment, self-aware
meaning	meaning	meaning	the secret of enlightenment,
meaning,	meaning,	meaning,	truth, enlightenment,
enlightenment,	enlightenment, knowledge is	enlightenment	to allah the long way to reach the fourth status
shayx	elderly	shayx	murshid disappointed

Sheikh San'an was the mediator,

He was aware of the mysteries of the unseen. Lisonut-tayr, (TM-67).

You are in pain with yourself,

The body is the soul of the oppressed. Lisonut-tayr, (TM-145).

The general pilgrimage to the painful alligator, even if he does not die

Why should death save Majnun and seduce Layla? Boboul-bizoya, I-508.

Navoi savti ishq Ahlin qilur khush,

If the morning dawns, the pain will not be happy. Navodirush-shabab, IV-93.

About Bataxis, love and pain. Muhokamatul-lug'atayn, (ML-182).

Which Omirni chu ishq eti zabun,

Zayil is a wise man between seven loves. Lisonut-Tayr, (TM-199).

Here, apparently, if juraturdur,

Lek means time away from the road. Lisonut-tayr, (TM-135).

After the moment of the Valley of Enlightenment,

Dashti beponlyogin supervises. Lisonut-tayr, (TM-157).



So, if such a word is a simple word in one sentence, then in another spelling is a terminology. The fact that they have a terminological status is a link to the character of the text. Even in the current Uzbek language, the terminology of all-system words is a very common phenomenon. In the beginning of the last century, Fitrat wrote that it was necessary to use this method when making a term: "in the madrasah of Christian life, as they say *Sunga shams*, they also say *Shams* in the Union of camels. When the Arabs turned their Greek knowledge into their own language, the shul camel took their words and made a "scientific invasion". As long as we do not do so, why"[21,131]. From the above it is possible to draw the following conclusions.

1. In the old Turkic language there were functional styles, including a scientific style.
2. The first scientific work written in the old Uzbek literary language in the scientific style is "Fununul-balogha" (XV a.c).
3. The work "Mezonul-avzon", written in the scientific style of Navoi, is distinguished by its richness in scientific terms.
4. The main majority of the terms in the "Mezon-avzon", which are written in a high way, are borrowed from the Arabic language.

#### USED LITERATURE

1. Sh O M A Q s O D O V A. R A S O L O V I. Q o n g u r o v R. R U S T A M O V H. Uzbek language Stylistics. Tashkent, 1983. 12-page; Mukarramav m. Scientific style of the current Uzbek literary language. Tashkent, 1984. 3 - 4 bet; Iskhakov a.I. Voprosi stanovleniya i razvitiya stily kazakhskogo literaturnogo yazika / / Razvitie stilisticheskix sistem literaturnix yazikov narodov USSR. Ashxabad, 1968. S.180.
2. T e n I s h e v e. R Funktsionalno-stilisticheskaya characteristic drevneuygurskogo literaturnogo yazika. Sosialnaya i funktsionalnaya differentiation literaturnix yazikov narodov USSR. Ashxabad, 1968. S.180.
3. Zakonomernosti razvitiya literaturnix yazikov narodov V sovetskuyu etokhu of the USSR. Location, 1969. S.63.
4. T O M o n o r N E. G. Yazik Kak Sistema sosiolingvistikicheskix system. Location, 1985. S.48
5. H A Y I T M E T O V A. The first theoretical guide from literature in Turkey / / Uzbek language and literature, 2002, issue 1, page 70.
6. Sheikh Ahmed Taraziy. Funonul-belag. // Uzbek language and literature, 2002, issue 4, page 78.
7. Yuldoshbekov J. "Fununul-Balog'a" and Uzbek literary studies // Uzbek language and literature, 2001, issue 5, page 33.
8. T e n I s h e v e. R Funktsionalno-stilisticheskaya characteristic drevneuygurskogo literaturnogo yazika. S. 69.
9. Sheikh Ahmed Taraziy. Funonul-belag. Tashkent, 1996. 24-bet.
10. Ubryatova E.I. O ponimani stilya i O stilyakh V yakutskom yazike // Razvitie stilisticheskix sistem literaturnix yazikov narodov USSR. Ashxabad, 1968. S. 307.



11. Examples are the collection of twenty volumes of excellent works by Alisher Navoi, published in 1987 – 2000 years, and the poet's work Mizanu'l-evzan (Me), published in 1993 year in Ankara.
12. Alisher Navoi. A perfect collection of works. Twenty volumes. 16-volume. Mozanol-avzan. Tashkent: Science, 2000. 94-bet.
13. Manual Or Manual. Mizanu'l-evzan. Prof. I'm sorry. Kemal Eraslan. Angara, 1993. 61-bet
14. The same work. 13-bet.
15. Muhammad Babir From Zahiriddin. In short. Preparing for publication, Saidbek Hasan. Tashkent: Science, 1971. 69-71-bet.
16. Manual Or Manual. Mizanu'l-evzan. 5-bet.
17. Tursunav He., Yerbaev B., Aliev A., History of the literary language of uzbek. Tashkent, 1995. 137-bet.
18. Location Scientific style of the current Uzbek literary language. Tashkent, 1984. 17-bet.
19. Aslanov V. Preemstvennost na dialektnix form v istorii azerbaydjanskogo yazika / / type naddialektnix form yazika m., 1981. S.56.
20. Location Scientific style of the current Uzbek literary language. Tashkent, 1984. 46-47-bet.
21. Eptorauf Fitret. Selected works. Volume IV. Tashkent: Spirituality, 2006. 131-bet.



**ACADEMICIA**  
**An International**  
**Multidisciplinary**  
**Research Journal**  
 (Double Blind Refereed & Peer Reviewed Journal)

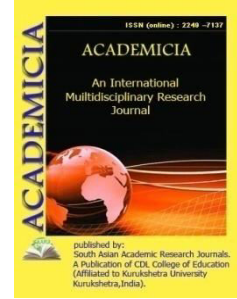

**DOI: 10.5958/2249-7137.2021.01942.X**

**OMAR TERMIZI'S BOOK OF KITAB UN-NIYYA**

**Mukhiddin ChoriyeV\***

\*Research central Researcher Resource Department,  
 Imam Termezi International,  
 UZBEKISTAN

**ABSTRACT**

*Research aimed at studying the rich scientific heritage of scientists attracts every student. Also, the scientific legacy left by Umar Termezi plays an important role in the development of the science of tafsir. And do not drive away those who call upon their Lord Morning and evening seeking His pleasure. No responsibility lies on you on their account and no responsibility whatsoever lies on them on your account that you should drive them away. He added to the verse, "There are some of you who desire the world, and there are some of you who desire the Hereafter." There is no point in saying that. It gives advice on the division of intent in the process of performing actions with intent. For example, he says, "Known actions are divided into many parts: work, action, speech, silence, attraction, prohibition, thought, and remembrance.*

**KEYWORDS:** *Tafsir, Kitab Un-Niyya, Omar Al-Tirmizi, Allaah, Believers And Disbelievers, Surah*

**INTRODUCTION**

He was a commentator, a preacher, a Sufi, a jurist. Umar al-Tirmidhi's Kitab un-niyya (The Book of Intention) is a clear indication of his wisdom. Umar al-Tirmidhi lived in the ninth century AH and the fifteenth century AD. There is no information about Umar's family, address or mausoleum. His works Tafsiri Surat al-Ikhlās and Kitab un-Niyya (The Book of Intention) have survived in manuscript form. According to Umar Riza Kahola (1323-1408 / 1905-1987), the works of Sufi and preacher Umar al-Tirmidhi, Tafsiri Surat al-Ikhlās and Kitab un-Niyya (The Book of Intention), were published in the Al-Khidaiyya Library in Cairo. 173, 17945.

**MATERIAL AND METHODS**

He wrote the book Kitab an-Niyat in 857 AH and 1453 AD. Umar al-Tirmidhi began to write Kitab un-niyya (The Book of Intention) following the book Tafsiri Surat al-Ikhlās. Before

beginning the Book of Intention, the author praises and says, "I have divided the Book of Intention into five chapters." He then quotes the following verse:

Say, 'Surely, my Prayer and my sacrifice and my living and my dying are (all) for the sake of Allâh, the Lord of the worlds. No associate-partner has He, and so am I ordained, and I am the first of the submitting ones (to Allâh)<sup>1</sup>.'

Surely, it is We Who have revealed the Book to you with the established truth to suit the requirements of truth and wisdom. So worship Allâh, being truly sincere to Him in obedience. Beware! Sincere and true obedience is due to Allâh alone. Those who choose others as a patron beside Him (say), 'We serve them only that they may bring us near to Allâh in station.' (It is absolutely wrong.) Allâh will judge the differences between these (believers and disbelievers). Indeed, Allâh does not guide him to success who is a liar, highly ungrateful<sup>2</sup>

(They have done it) though (in Islam) they were enjoined nothing more than to serve Allâh, bearing true faith in Him, (and) being upright, and to observe Prayer and to keep on presenting the Zakât. That is the true and firm conduct of faith<sup>3</sup>.

And do not drive away those who call upon their Lord Morning and evening seeking His pleasure. No responsibility lies on you on their account and no responsibility whatsoever lies on them on your account that you should drive them away. In case (you do it) you would be counted as the unjust<sup>4</sup>.

And that which you lay out as interest and usuary with a view to increase the wealth of the people does not help increase it in the sight of Allâh. But that which you present as the Zakât (purifying dues) with a view to seek (thereby) the pleasure of Allâh, it is they (- the regular payers of the Zakât) then who will increase (their wealth) many times over<sup>5</sup>.

But the one who guards against evil and keeps his duty (to God and others), shall most carefully be kept away from it (- the Fire)<sup>6</sup>.

And whatever wealth you spend (in doing good) will be fully credited to you and you shall not be treated unjustly<sup>7</sup>.

## RESULTS

But the case of (charity on the part of) those who spend their wealth seeking the good pleasure of Allâh and for their own consolidation and with firm faith, is like the case of a garden situated on a highly fertile land. It is hit by heavy rain so it yields its fruit manifold; but even if heavy rain does not hit it then a mere drizzle (is sufficient) for it. And Allâh sees well what you do. (Baqara 265)

But whoso disobeys Allâh and His Messenger and transgresses the limits imposed by Him He will make him enter Fire where he shall abide long, and for him is a humiliating punishment<sup>8</sup>. ( )

The author points out one thing here: There is no contradiction between the will of Almighty Allah and the will of the Hereafter; it is not the will of two different things. He added to the verse, "There are some of you who desire the world, and there are some of you who desire the Hereafter." There is no point in saying that. Because those who want the Hereafter do not want anything but Allah, and wanting the Hereafter means wanting Allah's reward and approval and hoping for His blessings. A fan is not accused of fearing hell, hoping for heaven.

## DISCUSSION

The Qur'an describes the Prophets and the righteous with salvation and fear, encouragement and fear, so there is no precedent in the Qur'an. Paradise is not only a house of emotional blessings, but it is also a house of great approval and looking at the face of God Almighty: "In it are the faces that shine and look at their Lord!" (Resurrection 22, 23). But on that day the disbelievers will be barred from their Lord, and that is the worst punishment. It is narrated on the authority of 'Umar that the Prophet (peace and blessings of Allaah be upon him) said: "Surely deeds depend on intention. Of course, everyone has a purpose. So whoever emigrates for the sake of Allah and His Messenger, his emigration is for Allah and His Messenger. Whoever emigrates for the sake of the world will attain it. Or if it's for a woman, she'll marry him. So, his migration will be for the same reason he did it," he continued. He also cites many hadiths and narrations.

## ACKNOWLEDGEMENT

Chapter Two. This chapter is about the truth of intention, and it teaches a person how to do intention. The chapter on the truth of intention begins with "Knowing that intention, desire, and revenge, in a sense, have their place, they are qualities of the soul," and they show their place. And in this chapter, too, he cites various hadiths and narrations. Chapter Three. It is about the statement of the goodness of intention from action. In this chapter, the pandu gives advice based on the hadiths that a person's intention is better than his deeds. In particular, he says: "Know that the intention is a secret and the deed is a manifestation. Only Allah knows the intention of a person." And in Surat al-Hajj 37, he says: But piety from Him will suffice for you. " Chapter Four. It is about the division of actions related to intention, in which it is known that intention has an effect on everything, and that it has no effect on impure things. q. The beauty of the intention, the superiority of the intention, does not make the haram lawful, nor does it remove the impurity that is the basis for the haram to become haram. Whoever intends to build a mosque or an orphanage or a madrasah by usury or theft, or by any other prohibited means, and to give alms to the poor and needy with this filthy property, good intentions have no place. The fact that he did something unclean will not be erased. This is evidenced by the following hadith: "Allah is pure and accepts only what is pure." It was narrated on the authority of Ibn Mas'ud that Allah does not wipe out evil with evil, but He wipes away evil with good, and impurity does not remove impurity. It is not permissible to purify an unclean animal by giving some of it, but it is obligatory to return it in its entirety. And again, the unclean property does not become the property of the recipient if it can be given as charity, but the unclean property remains the property of its original owner and cannot be disposed of until it is returned to its rightful owner or his heirs. It gives advice on the division of intent in the process of performing actions with intent. For example, he says, "Known actions are divided into many parts: work, action, speech, silence, attraction, prohibition, thought, and remembrance. But they are divided into three parts: sin, good and bad. Some good deeds become sins and some permissible deeds become good deeds because of the beauty of the intention or the ugliness of the intention. "Chapter Five. Bob is about the involuntary departure of intention. This chapter lists a number of allegations of misconduct. The Qur'an refers to the sincere intention conditioned on the servant in various ways: to desire the Hereafter, to desire the face of Allah, to aim at the face of Allah, or to seek His approval. Allaah says (interpretation of the meaning): We will give him the reward of this world, and we will give him the reward of the Hereafter. "(Ali Imran, 145) "And whoever desires this world's life and its finery, We will most certainly give them their reward therein, and they

shall not be harmed in the life of this world. For such, in the Hereafter, they will have nothing but the fire of Hell. All their good deeds in this world are in vain, and all their deeds are in vain.”(Hud, 15:16) The following hadith is narrated in this chapter: It is narrated that: “Allah has decreed good and evil. Then he said that. Whoever intends a good deed and does not do it, Allah will record it in His presence as a perfect good. If he intends to do so, Allah Almighty will write it down in His Presence from ten to seven hundred good deeds, and many times more. If he intends an evil deed and does not do it, Allah will record it as a good deed before Him. He said, "If he plots and acts, Allah will record it as an evil."

### **CONCLUSION**

This book is currently being translated and researched by the fireplace. We hope that in the future it will be a guide for the spiritual education of our youth. At the end of our talk, we recite the prayers that the Messenger of Allaah (peace and blessings of Allaah be upon him) taught us: “O Allaah! We apologize to you for associating shirk with what we know and apologize for associating shirk with what we do not know”.

### **REFERENCE**

1. Umar Termiziya fsirusuratilichlos (manuscript personal library)
2. UmarTermiziyniyatkitobi (manuscript personal library)
3. Holly Quran

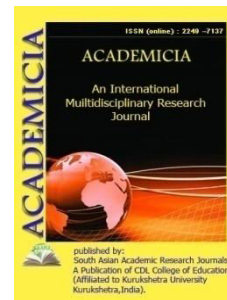
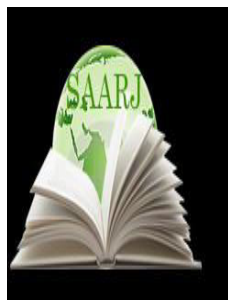

DOI: **10.5958/2249-7137.2021.01943.1**

## ULTRASOUND EXAMINATION IN THE PREVENTION OF COMPLICATIONS OF OPERATIONS ON THE BILIARY TRACT

**Akhmedov F.Kh\* ; Khamdamova M. T\*\***

\*Bukhara State Medical Institute named after Abu Ali Ibn Sino,  
Bukhara, Republic of UZBEKISTAN

\*\*Bukhara State Medical Institute named after Abu Ali Ibn Sino,  
Bukhara, Republic of UZBEKISTAN

### ABSTRACT

*The analysis of the results of ultrasound examinations of patients with acute cholecystitis allowed us to conclude that this method is an important diagnostic measure, with the help of which it is possible not only to improve the diagnosis of cholecystitis, to determine the choice of the method of cholecystectomy, but also to provide for the development of complications during its implementation. The literature data and our observations indicate that errors made at the diagnostic stage create not only difficulties in choosing the method of cholecystectomy, but also lead to the occurrence and development of complications. Depending on the density and prevalence of paravesical infiltrate, which creates the greatest danger of performing LHE, we identified three types of paravesical infiltrate that affect the choice of the method of surgical aid.*

**KEYWORDS:** Gallbladder, Ultrasound Examination, Cholecystitis, Laparoscopy.

### INTRODUCTION

The increase in the incidence of cholelithiasis is primarily associated with an increase in the average life expectancy, an increase in the number of elderly and senile patients and an increase in the welfare of the population [1,3,5,6]. Due to the growing number of patients with cholecystitis, the number of operations has increased dramatically in recent years, not only in large surgical clinics, but also in regional hospitals. From the point of view of physical, emotional, psychological and social functioning of patients, laparoscopic cholecystectomy (LCE) is superior to traditional. In laparoscopic cholecystectomies, the costs are compensated by reducing the time of patients' stay in hospitals and rehabilitation, reducing the volume of medications and reducing the output of disability and mortality [2,4,7].



Ultrasound is an elastic vibration of particles of a material medium with a frequency of more than 20 kHz, i.e. above the threshold perceived by the human ear. Modern ultrasound equipment is based on the principle of echo location, and all diagnostic devices operate in pulse mode. It is important to know that in the radiation mode, the sensor of the device works only 0,1% of the cycle time, whereas in the reception mode – 99,9% [1,3]. Such a rhythm of work is one of the factors that determine the safety of ultrasound examinations. Echography is not associated with ionizing radiation, which distinguishes it from, for example, computed tomography and puts it in the category of harmless techniques (echography is allowed to be used during pregnancy due to the absence of a possible damaging effect on the fetus), [1,6].

The widespread introduction of laparoscopic technologies in the surgical practice of acute cholecystitis has led to an increase in various complications. The literature data and our observations indicate that errors made at the diagnostic stage create not only difficulties in choosing the method of cholecystectomy, but also lead to the occurrence and development of complications. Failure to recognize such a danger at the diagnostic stage leads to an incorrect choice of the operation method, and performing laparoscopic cholecystectomy (LCE) "at any cost" causes serious errors, followed by complications. In the structure of patients with acute abdomen, acute cholecystitis occupies the second place after acute appendicitis, acquiring the significance of a socio-economic problem [3, 4,7].

The aim of the study was to improve the results of mini-invasive surgical interventions in acute cholecystitis using sonographic studies.

## **MATERIALS AND METHODS**

Giving a key place in the preoperative diagnosis to ultrasound examination (ultrasound), which gives not only the possibility of determining the main etiological factors of acute cholecystitis, but also the objectivity of the degree of severity of inflammatory changes in the gallbladder wall and paravesical space. The results of 235 ultrasound examinations of patients with acute cholecystitis, the course of which was complicated by paravesical infiltration, were analyzed.

## **Results**

We carried out the comparative analysis of results of laparoscopic and traditional cholecystectomy. Complications in a basic group: empyema (10,2%), edema of a gall bladder (7,8%), paravesical infiltrate (4,5%), phlegmon of a gall bladder (2,8%), and in control group: local peritonitis — 12%; empyema of a gall bladder — 11,1% and an edema of a gall bladder — 6,8%. Duration of a laparoscopic cholecystectomy was averaged by  $42,3 \pm 3,2$  minutes. Intraoperative complications: bleeding from a vesical artery and a bubble bed (2,73%), a trauma of the choledochus (0,27%) and in 1 one case damage of a duodenum.

The average percentage of conversion was (5,7%). Conversion reasons: existence of the inflammatory infiltrate in a neck of a gall bladder (28,9%), extensive adherent process in an abdominal cavity (20,5%) and bleeding from a vesical artery and a bed of a gall bladder (19,3%), technical difficulties, a choledocholithiasis and fistula of choledochus-bladder.

Postoperative complications: wound suppuration, expiration of bile, bleeding, pancreatitis. Lethality: at a laparoscopic cholecystectomy — 3 (0,21%), at traditional — 2 (0,65%).

The most characteristic ultrasound picture for paravesical changes is the presence of a zone of increased echogenicity, doubling and indistinctness of contours, thickening of the gallbladder wall. In addition, poor visualization of the neck of the gallbladder, shortening of the visible part of the choledochus, "a symptom of a continuous acoustic shadow" also indicate pronounced changes in the paravesical space.

Depending on the density and prevalence of paravesical infiltrate, which creates the greatest danger of performing LHE, we identified three types of paravesical infiltrate that affect the choice of the method of surgical aid. The first type is a loose infiltrate, the second type is a dense infiltrate, the third type is characterized by a more pronounced density with hyperechoic inclusions in the form of small bands of 0,5-1 cm in size, located in the projection of the gallbladder and the liver gate.

The revealed ultrasound changes allowed us to optimize not only the diagnostic process in acute cholecystitis, but also to justify the choice of the method of surgical intervention.

### CONCLUSIONS

1. The analysis of the results of ultrasound examinations of patients with acute cholecystitis allowed us to conclude that this method is an important diagnostic measure, with the help of which it is possible not only to improve the diagnosis of cholecystitis, to determine the choice of the method of cholecystectomy, but also to provide for the development of complications during its implementation.
2. Paravesical infiltrate in acute cholecystitis not only creates difficulties in performing laparoscopic cholecystectomy, but also conceals the dangers of its implementation.
3. Ultrasound examination in complicated acute cholecystitis allows you to determine the choice of the method of cholecystectomy, thereby reducing the frequency of complications.

### REFERENCES

1. Artyimyan Yu. A. Endovideokhirurgiya pri ostrom kholetsistite i ego oslozhneniyakh // Endoskopicheskaya khirurgiya — Endoscopic surgery, 2008, no. 5, P. 52-54.
2. Bondarev A. A. Vozmozhnosti vpolneniya lapa-roskopicheskoy kholetsistektomii pri ostrom kholetsistite // Endoskopicheskaya khirurgiya — Endoscopic surgery, 2007, no. 2, P. 11.
3. Voronin V. M. Ekonomicheskie preimushchestva videolaparoskopicheskoy khirurgii // Endoskopicheskaya khirurgiya -Endoscopic surgery, 2009, no. 1, P. 39-40.
4. Gulmuradov T. G., Nazarov F. N., Babadzhanov D. S. Comparative evaluation of the effects of conventional and laparoscopic cholecystectomy // Materialy respublikan-skoy nauchno-prakticheskoy konferentsii s mezhdunarod-nym uchastiem Tursunzade, 2007, P. 27-29.
5. Nazarov F. N., Khakimov A. N., Kurbonov A. M. Complications videolaparoscopic cholecystectomy //Materialy XII Moskovskogo mezhdunarodnogo kongressa po endoskopicheskoy khirurgii Moscow, 2009, P. 219-220.
6. Khamdamova M. T. Echographic features of the range of variability in the size of the uterus and ovaries in women of menopausal age using oral and injectable forms of contraception

//American Journal of Medicine and Medical Sciences 2020, 10(8): 580-583DOI: 10.5923/j.ajmms.20201008.09

7. Khamdamova M. T. Age echographic characteristics of the uterus and ovaries in women of the first and second period of middle age // Biology and integrative medicine. ISSN 2181-8827 2020. –2020. (march-april). - №2 (42) . – P.75-86.



**ACADEMICIA**  
**An International  
 Multidisciplinary  
 Research Journal**  
 (Double Blind Refereed & Peer Reviewed Journal)

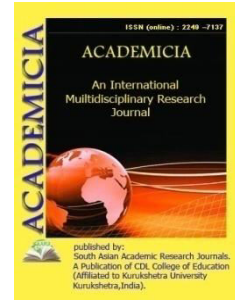

**DOI: 10.5958/2249-7137.2021.01944.3**

## MORPHOMETRIC FEATURES OF ANTHROPOMETRIC PARAMETERS OF ADOLESCENTS LIVING IN THE CITY OF BUKHARA ENGAGED IN ATHLETICS

**Hikmatova M. F\*; Khamdamova M. T\*\***

\*Bukhara State Medical Institute named after Abu Ali Ibn Sina.  
 UZBEKISTAN

### ABSTRACT

*Studies were conducted to study the anthropometric indicators of the body of children engaged in gymnastics, as well as the functional capabilities of the cardiovascular system of children aged 10-16 years living in the city of Bukhara. The assessment was carried out using centile tables with the determination of the harmony of physical development. The survey was conducted in the first half of the day, since during this period the studied indicators are most stable during the day. At the time of the study, the children were practically healthy. The assessment of physical development indicators was carried out according to centile scales, which is currently considered the most optimal and generally accepted way to assess physical development.*

**KEYWORDS:** *Anthropometric Studies, Gymnastics, Bone, Blood Pressure, Cardiovascular System.*

### INTRODUCTION

It is well known that one of the direct indicators of health, most reflecting the balance of the body with the environment, is physical development. The close connection between the state of health and physical development is especially pronounced during the school period, which determines the relevance of studying the pace of physical development. With prolonged exposure to negative factors, such as poor nutrition, physical inactivity, pronounced intensification of the educational process, which is expressed in an increase in the volume and complexity of the educational material and the number of lessons per day, leads primarily to disharmonious physical development, and thus to a decrease in the number of absolutely healthy children.

In **this regard**, the purpose of this work was to study the anthropometric indicators of the body of children engaged in gymnastics, as well as the functional capabilities of the cardiovascular

system (CCC) of children aged 10-16 years living in the city of Bukhara. The assessment was carried out using centile tables with the determination of the harmony of physical development.

### **Materials and methods of research**

The research was conducted on the basis of the Bukhara school, which included 92 students aged 10-16 years engaged in gymnastics, including 48 girls and 44 boys. The survey was conducted in the first half of the day, since during this period the studied indicators are most stable during the day. At the time of the study, the children were practically healthy. The physical development of schoolchildren was assessed according to the following criteria: body weight, body length, chest circumference (OGC), blood pressure (BP) and heart rate (HR). Further, the obtained data were analyzed and compared with the normative indicators, which are given in centile scales [1,3,5,6]. The measurement of total body size was carried out according to the generally accepted anthropometric method: body weight was determined using medical scales, a wooden height meter was used to measure body length, the chest circumference was measured using a centimeter tape. Blood pressure and heart rate were measured using an automatic tonometer, at rest on the right hand in a sitting position.

The assessment of physical development indicators was carried out according to centile scales, which is currently considered the most optimal and generally accepted way to assess physical development. Centile scales are a description of the frequency fractions of the distribution of the range of variation of features, absolutely independent of the mathematical distribution. Accordingly, these scales are more universal. They are convenient for mass preventive examinations of children, for identifying groups with "borderline" values and possible pathological deviations of signs. According to these scales, the values characteristic of half of healthy children of this sex and age are taken as the norm - in the intervals of 25-50-75 cents. The attention groups, that is, with borderline states, include children who fit into the range of 3-10 th centiles and 90-97 th centiles, and the group that requires additional examination, since this is a reflection of an obvious pathology-children with signs that go beyond the 3rd and 97th centiles. For a more complete description of the assessment of physical development, its integral assessment - harmony is used.

The conclusion about the harmony of the child's development is given based on the results of anthropometric measurements and the corresponding centile corridors in the centile tables: harmonious with a lag behind the age standards, if the data of the examined child are within 3-10 centiles; harmonious and age-appropriate, if all anthropometric indicators are within 25-75 centiles; harmonious with an advance of age, if the results obtained correspond to 90-97 centiles.

**The results of** our research have shown that the body length of boys who are engaged in gymnastics for 10 years exceeds similar indicators. Whereas at the age of 11, these indicators fully correspond to the parameters. At the age of 12 and 13, there is a jump in growth, about a year later than in girls. Most likely, this is due to the earlier entry of girls into the puberty period. At the age of 14, 15 and 16, the body length is within the normative limit. Our studies on the body weight of boys have shown that at the age of 10, 13, 14 and years, they have a steady increase in weight, again, as in girls, this is mainly due to an increase in the mass of adipose tissue. However, this is observed in boys 2 times more often than in girls, which is also confirmed by previous studies [1,2,4]. At the age of 13, there is a significant increase in the size of the chest circumference, but it still fits into the normative boundary. Apparently, this is due to

the entry into the puberty period. Boys of 10, 11, 12 and 13 years have normal indicators of the size of the OGC, and at 14 and 16 years there is a tendency to outstrip the age norm.

It is known that the intensity of the educational load is one of the factors that determine the functional state of the CCC of schoolchildren, which is a universal indicator of the adaptive capabilities of the body [2,3]. Our comparative analysis of heart rate revealed that in a larger number of surveyed middle and high school students, this parameter was significantly higher than the proper indicator. A significant increase in heart rate in girls is observed at the age of 11, during the beginning of puberty. In boys engaged in gymnastics, this indicator is significantly higher than the norm is reflected in 13, 14 and 15 years. The study of blood pressure indicators revealed that the level of actually measured systolic and diastolic blood pressure is significantly higher than the proper indicator in most age groups. 58.2% of boys and 51.9% of girls had normal blood pressure. However, this trend is more evident during puberty. An increase in blood pressure at this time is considered as a physiological reaction aimed at maintaining blood supply at an optimal level with a rapid increase in height and body weight [1, 2,7]. In girls, the highest level of blood pressure, exceeding that of boys, is detected at 11, 12 and 14 years. In boys, these values were higher at 10, 13, 14, 15 and 16 years. The differences in the dynamics of indicators are due to different terms of the beginning of puberty. The results obtained indicate that the pronounced stress of the CCC and the mechanisms of regulation is more observed in boys than in girls. In this regard, the critical period of the functional state of the CCC is determined, in girls it is the age of 12, 13 and 14 years, and in boys it is the age of 13, 14 and 15 years. During this period, it is necessary to pay attention to the physical condition of the child, otherwise the increasing dysfunction of the CCC can lead to a pathological condition.

Thus, the conducted research has shown that over the past 10-15 years there is a clear trend of accelerating the physical development of gymnastics, accompanied by an increase in the load on the CCC, which must now be taken into account when working with this category of adolescents.

#### **LIST OF LITERATURE:**

1. Afanasievskaya Yu. S. Anthropometric characteristics of young people in Krasnodar and the Krasnodar Territory // Actual problems of medical science and education: Proceedings of the II Interregional Scientific Conference. Penza, 2009. pp. 11-12.
2. Zankovets, V. E. Encyclopedia of testing // monograph. - M.: Sport, 2016. - 457 p.: ill. - Bibliogr.: p. 453
3. Mironov D. L. Criteria for visual assessment of running technique with max. speed at athletes // Izvestiya Tula State University. Physical Culture. Sport. - 2015. - No. 1. - pp. 71-774.
4. Khamdamova M. T., Tukhtasinovna K. M. Echographic features variability in the size and shape of the uterus and ovaries in women of the second period of adulthood using various contraceptives // Asian Journal of Multidimensional Research (AJMR). - 2020. - T. 9. - №. 5. - C. 259-263.
5. Khamdamova M. T. Age and individual variability of the shape and size of the uterus according to morphological and ultrasound studies // Problems of biology and medicine. - 2020. - №. 1. - C. 116.



6. Khamdamova M. T. Anthropometric characteristics of the physical status of women in the first and second period of middle age // *New day in medicine*. – 2020. – №. 1. – C. 29.
7. Khamdamova M. T. Age and individual variability of the shape and size of the uterus according to morphological and ultrasound studies // *Problems of biology and medicine*. – 2020. – №. 1. – C. 116.



**ACADEMICIA**  
**An International  
 Multidisciplinary  
 Research Journal**  
 (Double Blind Refereed & Peer Reviewed Journal)

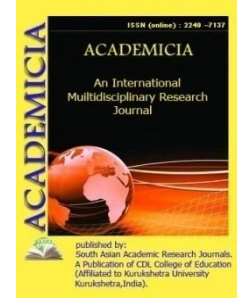

**DOI: 10.5958/2249-7137.2021.01945.5**

## ELEVATION OF PHYSICAL AND MENTAL STRENGTH WITH SPORTS PERFORMANCE WITH TRADITIONAL EXERCISES AND YOGA

**Dr. Anjana Lohan\***

Associate Professor,  
 Head, Deptt. of Physical Education,  
 S.D. Mahila Mahavidyalay, Narwana ( Jind), INDIA

### ABSTRACT

*Practicing yoga may help you improve range of motion and balance while also strengthening your muscles and resisting weight loss as well as increasing your overall strength and stamina. When it comes to cross-training, yoga may be the best option. With its focus on breathing and flexibility, yoga may assist athletes enhance their performance on the field of sports. Even if you don't engage in sports on a regular basis, you're probably aware of the effect breathing has on your performance. Reduced performance anxiety and improved focus are built on the basis of deep, calm breathing. Yoga can assist you in creating a good breathing routine. Sportspeople may benefit from yoga practise since it integrates the mind-body connection.*

**KEYWORDS:** *Yoga In Sports, Physical Strength, Athletes Performance, Sports In India, Yoga In Sportspersons*

### INTRODUCTION

The main goal of yoga postures is to strengthen the core. Slow, concentrated motions need a strong core, and many exercises include isometric contractions, which offer a new kind of resistance training to your usual machine-based routines..

Slow, steady flexibility exercises are included into yoga practises, making them excellent for athletes. Regular yoga practise may help you become more flexible and mobile, as well as reduce muscular stress. Increasing your range of motion may benefit your performance in any sport, from running to golfing.

**Enhance your sense of equilibrium.**

To include balancing exercises in your training, try yoga. Athletes often neglect balancing exercises, despite the fact that they are one of the most efficient methods for correcting muscular imbalances and other mechanical issues. Sports and weight training regimens often include repeated movements that work just a small number of muscles while neglecting larger ones. Yoga has the ability to correct these inequities.

**Cross-train using this product**

Yoga is a wonderful low-impact method to stay fit while doing something completely different. Athletes that participate in the same activity or fitness programme year-round need to cross train. Incorporating new exercises may help you stay healthy, avoid injury, and have more fun while training. It can also help you recover from tough aerobic and strength-training sessions. There are hundreds of postures in yoga that may offer a workout for every athletic requirement, whether it's high or low intensity.

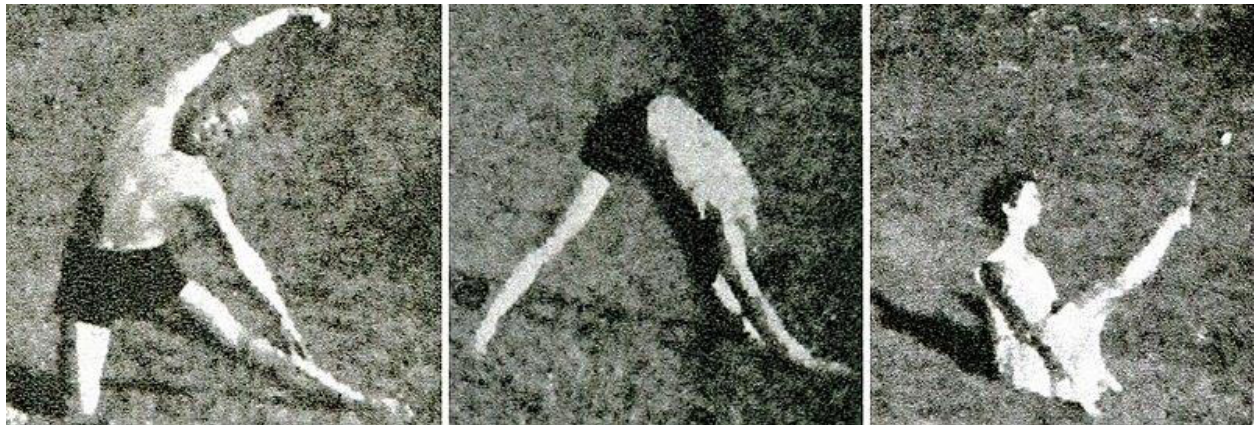

Figure 1 : Historical Use of Yoga Exercises by Sports Players

**Wide Range of Exercises**

There are many types of yoga, ranging from fast-paced practises that hold postures for long periods of time and constitute an intensive strength and balance exercise to more slow-paced practises that hold postures for few minutes.

**Described and Practiced Safely: The Most Popular Styles**

Yoga is a great way to stay in shape, but it comes with certain risks, which is why you should understand how to avoid being injured when doing yoga. More study is being done on the health benefits of yoga, but for the time being it's hard to say for sure how beneficial it is. National Institutes of Health (NIH) studies have shown a connection between yoga practise and reduced low back pain, as well as fewer complaints of arthritis, headache and carpal tunnel syndrome-related chronic pain and lower blood pressure, pulse and respiration rates.

Everyone, including athletes, may benefit from yoga. Among other things, yoga helps to strengthen your core and improves your general strength while also improving your flexibility and balance. The addition of yoga to the training programme of any athlete would be very beneficial. Here are a few additional specifics about the perks:

Strength: Lifting weights won't offer you the strength you'll get from regularly supporting your own weight.

Range of motion is improved with regular yoga practise because it improves flexibility and ease of movement. Sporting activities that involve a lot of swinging (like tennis or golf) may gain a lot from this. A person's overall level of flexibility also aids in the prevention of injury.

Yoga's balancing postures help you stay on your feet and avoid injuries by improving your general balance. You're less likely to break or tumble over if you learn to be soft and go with the flow.

Athletes that engage in endurance sports such as jogging, triathlons, and Iron Mans benefit from yoga's increased endurance. Everything becomes a meditation when you learn to tune in to your body and mind. This includes sports. Additionally, yoga teaches you the importance of taking things slow and steady so that you may stay committed to your goals.

Core: Almost all of yoga's exercises focus on strengthening your core. A healthy back is a result of having a strong core, as is a healthy overall body.

Strength: Yoga helps build the tiny stabilising muscles that are often overlooked in other types of physical training but are crucial for preserving your joints and spine (among other things).

Yoga also aids in the recovery of injured sportsmen. In other words, you're listening to your body and providing the care it requests and demands. It is also a wonderful counter-action since yoga lengthens all of the muscles that athletes spend so much time constricting.

When you learn to move with ease and stop trying to force things, you'll avoid injuries, and your body will open up to your mind as well, giving you more flexibility wherever you go.



Figure 1 : Hockey Yoga

Poses that work well for athletes include the following:

Exercise with a wheel: improves arm strength and flexibility in the back, shoulders, and hip joints.

### **Professional Sportsmen and Yoga**

Yogis have been doing this kind of exercise since ancient times to help their bodies stay flexible, to keep their muscles young, to improve circulation, and to strengthen their internal organs. But yoga goes much beyond this.

Yoga has been shown to enhance focus, eliminate constipation, ease stomach problems, and decrease body fat. Aside from improving the mind-body connection, research shows that yoga also boosts self-confidence, improves self-discipline, and increases vitality by increasing energy flow throughout the body. According to what research says, it seems that yoga has many advantages and may help us become a more well-balance, calm, focused, and successful individual. Because of this, yoga's advantages may be applied to a wide range of fields, including professional sports. In this article, the advantages of yoga for professional athletes will be discussed, as well as how yoga may improve an athlete's overall performance.

To fully grasp how Yoga may help professional athletes, one must first examine what it takes to be a good athlete and play a sport effectively. Everyone knows that in order to be good at any sport, whether it's tennis, volleyball, surfing, swimming, or even jogging, you need a solid foundation of fundamental skills and a consistent training regimen to keep your body in top shape. To become good at anything, you have to put in a lot of time, effort, and dedication to it. Having a flexible, strong, and controlled body is also essential, since poor performance will result if one cannot move their body with the necessary grace, velocities, and speeds. Similarly, a person's performance would suffer if they cannot keep up their endurance or stamina for the necessary period of time.

A person must be able to focus and concentrate with confidence on the job at hand without distraction or shyness in order to perform a sport effectively. As a result, overcoming obstacles such as diversions, hardship, and stress is critical. 'The hardest aspect of any accomplishment is the management of distractions and unfavourable circumstances,' says sports coach B.P Bam, who adds that "sporting abilities need the attainment of deep concentration" and "living in every moment". Without the ability to "score the goal," "serve the ball," or cope with audiences who "cheer or boo," success will be a long way off. Victory will be difficult to come by. As a result, a professional athlete must be able to retain mental equilibrium and balance as well as remain attentive, focused, and aware throughout the athletic action. So, how can yoga help a sportsperson develop their mind and body so they can give their best on the field ? Practicing yoga involves adopting certain bodily positions while controlling one's breathing, focusing on one's inner peace, and letting go of stress. To learn how to connect the mind and body via yoga, a person must be willing to be in the present moment. Practicing the breathing methods taught in yoga, known as pranayama, allows one to concentrate on the breath while also calming the mind and improving one's capacity to concentrate.

As Swami Vishnudevananda points out, "with pranayama, man's will-power, self-control and concentration power may be strengthened."#, he says that pranayama is important for improving mental serenity and focus. Bringing oneself into the present by paying attention to one's breath is



an excellent habit to develop, as stated by B.P Bam. That's when I started paying attention." # The Nath sect's study of pranayama, he says, was particularly useful for sharpening one's concentration. # Professional sportsmen may benefit from Hatha Yoga's internal cleaning techniques not only to improve their physical purity and well-being, but also to increase their focus. Swami Vishnudevananda emphasises this issue, stating that "the concentration capacity of the mind rises to a very high degree when the body is devoid of physical impurities." # When done correctly, pranayama may assist in reviving and energising the body.

Yoga asanas, or poses, are prescribed to assist people improve their mental agility and focus. Long-term mental concentration is required to maintain a comfortable posture with stability, relaxation, and comfort. When playing sports at a high level of competition, you'll benefit from this since it helps you build mental and physical strength and focus. According to Swami Sivananda's teachings, regular yoga practise "will train [the mind] to be obedient, loyal, and effective in whatever they set out to do."

It is through the practise of asanas that one is able to develop a harmonious and balanced mind-body connection and a strong and steady state of mind. As a result of asana practise, internal organ function and efficiency increase, which benefits the whole body. The interior workings of the body's organs are improved when cells are fed and rejuvenated. It is widely accepted by Yogic authorities that "yogic exercises are primarily designed to maintain the proper curvature of the spine and increase its flexibility"#. They also claim that "balancing asanas" improve cerebellum function and muscle coordination, helping to achieve grace and fluidity in movement.

Asanas in the inverted position may help you change undesirable habits and outdated patterns of behaviour, such as an inefficient swimming stroke or a volleyball swing. Professional athletes who want to improve their results must be able to alter their bodily motions and behaviours on the fly in order to do so. A fresh light is shed on previous patterns of behaviour and being while doing inverted asanas, which alters typical patterns (both emotionally and psychically). Additionally, inverted asanas have been shown to enhance health, lower stress levels, and boost confidence.

To help build a skill or reinforce a new pattern of behaviour or beliefs, try using Yoga Nidra and visualisation. He states, "all of the top Indian sportspeople who have worked with me have been making extensive use of various visualisation techniques." B.P.Bam emphasises this point, stating, "purification of memory or reinforcing a skill's best qualities by remembering them again and again makes a major contribution." # Chanting and meditation may also assist to decrease tension and anxiety and to develop a mental serenity and poise that is useful while performing under pressure.

It's possible that a regular yoga practise may help you gain more core stability and strength. Various postures use muscles that aren't used as much while doing other types of exercise like jogging, cycling, or swimming. You can better support your main muscle groups if you work on the smaller ones as well. Increasing the size and strength of your muscles will enable them to operate at their best and improve your overall exercise performance.

Improved exercise performance and injury avoidance need good balance and coordination. As you go through yoga postures, you'll improve your balance, coordination, and focus. You may decrease your chance of falling and enhance your exercise technique by increasing your balance. This will help you perform better in general.



Poses that improve flexibility are included in a full yoga practise along with those that test your strength and balance. A person's ability to move freely is mostly determined by their joint and muscular flexibility. More force may be exerted during athletic motions such as a golf swing, a swimming stroke, or a baseball pitch with a larger arc of motion.

In addition to physical training, yoga emphasises mental training. Even if you're not a fan of meditation, yoga incorporates a variety of different methods that may help you concentrate better during physical activity or sports. Many yoga postures, for example, are most effective when breathing is synchronised with movement. Endurance athletes, such as runners, bikers, and swimmers, may benefit from this.

Yoga is an excellent complement to any workout programme because of the many advantages it offers for enhancing athletic performance. Every athlete may start the programme at their own speed and profit from it. This makes it unique. So, now is the day to take a risk and go on the mat!

## CONCLUSION

Practicing yoga helps to mobilise joints, stretch ligaments and other connective tissues, tighten and tone muscles, and improve spinal flexibility and organ strength. During a yoga session, you'll be able to stretch, relax, deep breathe, increase circulation, and focus your mind. A professional athlete may benefit from yoga because it helps them improve their focus, nurture a peaceful and relaxed state of mind, and develop the link between their mind and their body, resulting in improved muscular coordination and fluidity in their movements. The benefits of yoga extend to professional athletes as well, strengthening internal organs like the heart, lungs, and liver, as well as helping them retain their physical fitness and agility. Stress and anxiety may be reduced and self-confidence can be developed via yoga. Every one of these factors is essential for athletes to reach their full potential and perform at their very best. According to the information presented above, in order to successfully complete a sports activity, one must have a high level of attention and focus, as well as a calm and regulated state of mind. According to Swami Sivananda, "concentration is a prerequisite for success in every field of life." # The practise of yoga may assist a sportsperson maintain mental balance and self-control under pressure or hardship. Yoga may help people gain mental and physical mastery over their bodies. As a result, Yoga may assist athletes achieve their optimum performance by developing mental control and focus.

## REFERENCES

- [1] Pratinidhi, Bhawanrao Shrinivasrao Pant (1938) [1929]. Morgan, Louise (ed.). The Ten-Point Way to Health = Surya Namaskars. London: J. M. Dent. OCLC 156801198.
- [2] Rhodes, Darren (2016). Yoga Resource Practice Manual. Tirtha Studios. ISBN 978-0-9836883-9-6.
- [3] Saraswati, Swami Satyananda (1996). Asana Pranayama Mudra Bandha (PDF). Yoga Publications Trust. ISBN 978-81-86336-14-4.
- [4] Scaravelli, Vanda (1991). Awakening the Spine. Harper. ISBN 978-0-06-242853-0. OCLC 907678659.

- [5] Schneider, Carrie (2003). *American Yoga: The Paths and Practices of America's Greatest Yoga Masters*. Barnes & Noble. pp. 60–65. ISBN 0-7607-4558-7.
- [6] Shearer, Alistair (2020). *The Story of Yoga : from Ancient India to the Modern West*. C. Hurst. ISBN 978-1-78738-192-6. OCLC 1089012347.
- [7] Singleton, Mark (2010). *Yoga Body : the origins of modern posture practice*. Oxford University Press. ISBN 978-0-19-539534-1. OCLC 318191988.
- [8] Beatrix Hauser (ed.). (2013). *Transnational Exchange and the Genesis of Modern Postural Yoga. Yoga Traveling: Bodily Practice in Transcultural Perspective*. Springer. ISBN 978-3-319-00315-3.
- [9] Sjoman, Norman E. (1999) [1996]. *The Yoga Tradition of the Mysore Palace* (2nd ed.). Abhinav Publications. ISBN 81-7017-389-2.
- [10] Srinivasa, Narinder (2002). Gharote, M. L.; Devnath, Parimal; Jha, Vijay Kant (eds.). *Haṭharatnāvalī (a treatise on Haṭhayoga) of Śrīnivāsayogī* (1st ed.). The Lonavla Yoga Institute. ISBN 81-901176-96.
- [11] Strauss, Sarah (2005). *Positioning Yoga: balancing acts across cultures*. Berg. ISBN 978-1-85973-739-2. OCLC 290552174.
- [12] Swanson, Ann (2019). *Science of yoga : understand the anatomy and physiology to perfect your practice*. New York, New York: DK Publishing. ISBN 978-1-4654-7935-8. OCLC 1030608283.
- [13] Syman, Stefanie (2010). *The Subtle Body : the Story of Yoga in America*. Farrar, Straus and Giroux. ISBN 978-0-374-53284-0. OCLC 456171421.
- [14] Tiruka (1977). *Suryanamaskara (in Kannada)*. Malladhihalli: Sarvodaya Mudranalaya, Anathasevashrama Trust. p. v. OCLC 20519100.
- [15] Van Gennep, Arnold (1965) [1908]. *The Rites of Passage*. Routledge & Kegan Paul. OCLC 752944237.
- [16] Veenhof, Douglas (2011). *White Lama: The Life of Tantric Yogi Theos Bernard, Tibet's Emissary to the New World*. Harmony Books. ISBN 978-0-385-51432-3.
- [17] Vishnudevananda, Swami (1988) [1960]. *The Complete Illustrated Book of Yoga*. Three Rivers Press. ISBN 0-517-88431-3.

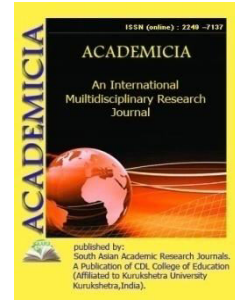
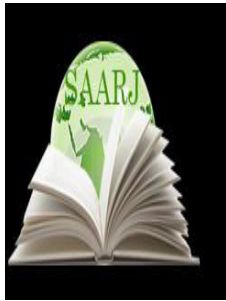

DOI: [10.5958/2249-7137.2021.01946.7](https://doi.org/10.5958/2249-7137.2021.01946.7)

## TEACHING ECONOMICS AND THE EVOLUTION OF MODERN ECONOMIC EDUCATION IN HIGHER EDUCATION INSTITUTIONS

**Nargiza. A. Inagamova\***

\*Assistant,  
Chair of Economy and Real Estate Management,  
Tashkent Institute of Architecture and Construction,  
UZBEKISTAN

### ABSTRACT

*Nowadays, economic knowledge is important for every student. There are give main information about teaching economics and the evolution of modern economic education in higher education institutions in this article. To teaching economics the concept of neoclassical synthesis, historical and modern teaching methods are expressed. The process of completing a higher education—highly dependent on personal initiative can lead to a pattern of life-long learning. From an economic point of view, higher education has become an in demand commodity. In each period, in this or that country, certain people (scientists or governors) put forward and implemented such economically important thoughts, ideas, theories, concepts, which in one case led to the development of states and peoples, and sometimes to depression.*

**KEYWORDS:** *Teaching Economics, Neoclassical Synthesis, Samuelson, Crisis-Free Economic Cycle, Nobel Award Winners, "Economics", Limited Resource, Growing Consumption.*

### INTRODUCTION

Most higher education institutions have some form of voluntary peer tutoring. Number of efforts to examine the effects of such programs on student outcomes. Most of these fails to acknowledge the possibility of self-selection bias. Should such endogeneity exist, estimates regarding the extent to which help centers improve student performance will be biased. Mankind has come a long way in its many thousands of years of economic and social development. In each period, in this or that country, certain people (scientists or governors) put forward and implemented such economically important thoughts, ideas, theories, concepts, which in one case led to the development of states and peoples, and sometimes to depression. It is extremely practical and theoretically useful to study and analyze these economic ideas in detail, to distinguish between

them and to apply them to the present day, that is, to life, because they have many years of experience.

### **Main body**

The twentieth century witnessed the evolution of the college degree from a luxury to a necessity the capstone of a series of academic experiences that ready an individual for a fulfilling life in a complex and demanding society. That preparation leads not only to a better economic future but also provides the individual with a richer understanding and appreciation of the world and human society. The process of completing a higher education—highly dependent on personal initiative can lead to a pattern of life-long learning. From an economic point of view, higher education has become an in demand commodity. It is also an expensive undertaking, paid for in a complex array of transactions that are replete with direct and indirect subsidies. This seeming opaqueness of higher education's finances coupled with rapid rises in tuition have contributed to a general misunderstanding of the economics of higher education, leading some to charge that colleges and universities are out of control. A few government representatives have even suggested the imposition of tuition price controls. Higher education's finances are complex, and for reasons that spring from the very heart of the enterprise the cost of providing a manually intensive, highly customized education for a student is expensive. This article will explore the economics of higher education in the United States (and at Cornell University in particular), focusing primarily on undergraduate education and touching on these interrelated topics:

- the concept and evolution of the modern university, including its relationship to the state and its approach to shared governance;
- the economic constructs of cost (university expenditures), price (student charges for tuition, fees, room, board, and related services), and subsidy, including financial aid;
- the cost structure of higher education;
- the combination of competitive and self-imposed pressures that affect that cost structure;
- the approaches used to manage the enterprise, control costs, and guide development;
- the issues of access and affordability, which include concerns over rising student debt and the economic return on the investment in higher education for both the individual and society.

**Education economics** or the **economics of education** is the study of economic issues relating to education, including the demand for education, the financing and provision of education, and the comparative efficiency of various educational programs and policies. From early works on the relationship between schooling and labor market outcomes for individuals, the field of the economics of education has grown rapidly to cover virtually all areas with linkages to education.<sup>6</sup>

There are two overarching goals in mind when teaching economics: introducing students to economic theory and practice contributing in a compelling way to each student's liberal arts or general education. These complementary goals can be challenge to achieve in a culture in which quantitative and qualitative analysis or what we might summarize as technology and the humanities are viewed as substitutes. Current social and economic policies reinforce this perceived dichotomy by focusing upon raising student interest in the so-called STEM subjects (science, technology, engineering, and mathematics) while students of other subjects

(particularly in the humanities) are increasingly concerned about their job market prospects. As economists and liberal artists, however, we know that technology and the humanities are more likely to be complements than substitutes, and that economies of scope may certainly arise in teaching and learning these subjects together rather than independently. The premise of this paper is that this could be made plain to students by teaching economics with our humanities as the technology. Three concrete techniques for doing so are set forth in the remainder of this paper

**The essence of the concept of neoclassical synthesis.** A number of disasters in the economy, in particular, mass unemployment and inflation, remain one of the main problems in socio-economic development. The question of how to ensure a moderate and full employment of the population, the growth of real incomes is of interest to everyone, including economists. What is especially important are the secrets of a crisis-free economic cycle. These and other issues are dealt with in the direction of neoclassical synthesis, in which the truths and rules previously defined by classical economic theory are synthesized with theories of income generation in the modern era. According to P. Samuelson, a prolific writer in this field, "neoclassical synthesis" is a combination of modern neo-Keynesian and neoliberal rules and "truths" with the first neoclassical ideas, as well as some postulates of the classical school and, above all, theories of income generation. With the emergence of this new idea, mixed views prevail in economic analysis, offering different forms of economic regulation. At the present time in the macroeconomic education of the economy are mainly involved cytosis (mixture) of three doctrinal views. These are 1) Keynesian doctrines of various modifications, 2) theories of supply economy, and 3) monetarism. According to Keynesian views, the active participation of the state in the economy is widely promoted. This is based on ensuring a high level of production, employment, mitigation of cyclical development with changes in the situation. At the same time, the main focus is on the state budget, thus directly regulating the demand for payment opportunities. According to monetarists, the principle of non-interference in economic life is supported. According to some, neoclassical synthesis involves not only the regulation of the economy by the state, but also the modeling of the overall economic equilibrium. Some scholars (A.B. Anikin) say that Samuelson's neoclassical synthesis is primarily seen as a combination of classical microeconomics with new macroeconomics. The above views can be divided into three parts: the first is to ensure full employment in the economy, and this principle can be applied in conjunction with elements of a free market economy (economic liberalism), as well as elements of the Keynesian concept that limits the free market. In particular, public policy combines fiscal and monetary systems and anti-inflationary opportunities in the concept of "natural norm of unemployment" (M. Friedman), as well as the principles of Erhard-Rope's "Social market economy". In the second view lies the old and new value theories in the theory of value (expensive) put forward by the neoclassicists at the end of the XIX century, or the theory of cost and the theory of maximum utility. Here we are talking about the system of approaches proposed by A. Marshall, a representative of the second wave of marginalists. It deals with the assessment, supply and demand, and general economic equilibrium of W. Pareto and others. According to the third view, the current model of general economic equilibrium is based on both macro and micro economic studies. In this study, the previous pure economic theory and perfect competitive views are abandoned, and the spheres of production and consumption are not opposed to each other. These views also take into account the influence of Keynes's

"Psychological Law", the rapid growth of income relative to consumption, the "Veblen effect" and other non-economic factors.

## CONCLUSION

Neoclassical synthesis has become a leader in recent economic teachings, and this new direction is usually associated with the ideas of the American P. Samuelson and his book "Economics". It should be noted that there are versions of this book published by other authors, which also analyze these issues. The main feature of the new approach is that it comprehensively studies the economic ideas, theories and doctrines that emerged in the previous period, and summarizes the rational ideas in all of them. how much should be analyzed. If this is interpreted differently, the issue of "using limited resources to fully meet the ever-growing needs" will be considered. Neoclassical synthesis uses a creative mixture of Keynesian, neoclassical and neoliberal ideas. In particular, econometric methods are penetrating deeper into the economy. Econometric methods are widely used in practice in all areas of economic education. In this regard, the Republic has also achieved good results.

## REFERENCES:

1. A. Islamov, E.T.Egamov, History of economic doctrines. TMI, 2001.
2. Abramitzky, R. (2015). Economics and the modern economic historian (No. 21636). NBER Working Paper. Cambridge.
3. MA. Acemoglu, D., Cantoni, D., Johnson, S., and Robinson, J. A. (2011). The Consequences of Radical Reform: The French Revolution. *American Economic Review*, 101(7), 3286– 3307.
4. Sobirovna, T. R. (2021). Issues of further improvement of water cadastre legislation of Uzbekistan. *ACADEMICIA: An International Multidisciplinary Research Journal*, 11(4), 1241-1253.
5. Тошбоева, P. C. (2020). Provision Of Inventory Information About Natural Resources: Problems And Ways Of Their Solution. *Journal Of Legal Research*, 5 (3).
6. Тошбоева, P. C. (2020). Ecologization Of Uzbekistan Economy: Legal Aspect Of Improvement Of Investment. *Legal Research Journal*, (Special 5).
7. Mulaydinov, F. (2021). Digital Economy Is A Guarantee Of Government And Society Development. *IlkogretimOnline*, 20(3), 1474-1479.
8. Mulaydinov, F. M. (2019). Econometric Modelling of the Innovation Process in Uzbekistan. *Форум молодых ученых*, (3), 35-43.
9. [https://en.wikipedia.org/wiki/Education\\_economics](https://en.wikipedia.org/wiki/Education_economics)
10. Belfield, Clive & Levin, Henry. (2003). The Economics of higher education. [http://lst-iiiep.iiiep-unesco.org/cgi-bin/wwwi32.exe/\[in=epidoc1.in\]/?t2000=018893/\(100\)](http://lst-iiiep.iiiep-unesco.org/cgi-bin/wwwi32.exe/[in=epidoc1.in]/?t2000=018893/(100)).



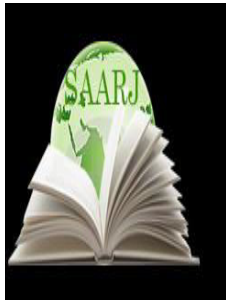

**ACADEMICIA**  
**An International**  
**Multidisciplinary**  
**Research Journal**  
 (Double Blind Refereed & Peer Reviewed Journal)

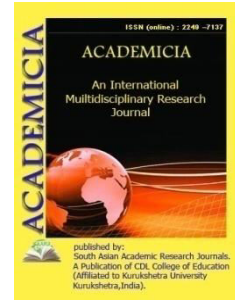

**DOI: 10.5958/2249-7137.2021.01947.9**

## TAX RISKS ANALYSIS AND THEIR ROLE IN THE ECONOMY OF COUNTRY

**Muqaddas. R. Elbayeva\***

\*Assistant of the department of Economics and Real Estate Management,  
 Tashkent Institute of Architecture and Construction,  
 Tashkent State University of Economics,  
 UZBEKISTAN

### ABSTRACT

*A number of projects and decrees are currently being developed to digitize and secure the state tax system. There are given main information about tax risks analysis and their role in the economy of country in this article. Definitions of several necessary terms are provided to reinforce knowledge of tax risks and perform clear analysis practices. This is a dangerous situation, which can lead to non-payment and (or) incomplete payment of taxes and fees to the budget. Analytical data is collected according to the level of tax risk and analyzed by regions, and divided into levels and automatically transmitted to the regional tax authorities. Tax risk analysis helps in identifying tax violations. Such analysis, as well as evaluation of the results, is carried out using the automated software product "Tax Risk Detection, Analysis and Assessment" (Threat Analysis).*

**KEYWORDS:** *Tax System, Tax Risks, Risk Detection, Taxpayers, Potential Tax Risk, Tax Risk Level, Tax Risk Analysis.*

### INTRODUCTION

Tax risks: the tax risk of the entrepreneur is a change in tax policy (the emergence of new taxes, the abolition or reduction of tax benefits, etc.), as well as changes in the value of tax rates. The tax risk of the state is a decrease in budget revenues as a result of changes in tax policy or tax rates. Uzbek tax law obliges taxpayers (or their tax agents) to calculate and pay taxes and fees correctly and on time. Unfortunately, this perspective often causes us to become overwhelmed when it's time to start a project. For example, there may be occasional errors in filling out tax returns. And sometimes some unscrupulous taxpayers deliberately try to evade taxes. Tax risk analysis helps in identifying tax violations. Such analysis, as well as evaluation of the results, is

carried out using the automated software product "Tax Risk Detection, Analysis and Assessment" (Threat Analysis). The program was developed by the State Tax Committee in cooperation with international organizations based on the experience of developed countries and was implemented in accordance with the Regulation approved by the Cabinet of Ministers No. 1. The program works automatically, summarizing the internal and external data of the tax authorities. The main outcome of the program is to ensure compliance with tax laws and to help taxpayers who make small mistakes and shortcomings to correct them.

**Main body.** How does the program work? The program analyzes data from various sources not prohibited by law. For example, tax and financial reports, information reflected in the cards of personal accounts of taxpayers, materials of tax audits, appeals testifying about the facts of tax violations of individuals and legal entities, statistical agencies and the media and information from other sources.

The program determines the level of tax risk by scoring from 1 to 100 on the basis of tax risk criteria. In this case, the segmentation of taxpayers is categorized as follows:

- Taxpayers who have scored from 81 to 100 points - are at high risk (red corridor) and will be assigned a tax audit;
- Taxpayers with a score of 30 to 80 are at medium risk (yellow corridor) and will be assigned a chamber tax audit;
- Taxpayers who earn from 1 to 29 points are at low risk (green corridor) and are not subject to control measures.

As a result, the probability of non-fulfillment and (or) incomplete fulfillment of the tax liability is determined. This is a dangerous situation, which can lead to non-payment and (or) incomplete payment of taxes and fees to the budget. Analytical data is collected according to the level of tax risk and analyzed by regions, and divided into levels and automatically transmitted to the regional tax authorities. If the level of risk is small and the program shows that the taxpayer made a mistake deliberately did not try to evade taxes, then the staff of the regional tax authorities will help the taxpayer to correct the report. In other cases, an in-house or audit tax audit is scheduled, depending on the level of risk to the taxpayer. It should be noted that this will allow taxpayers to identify some of their risks and provide explanations through the personal account of the taxpayer.

Information on tax risk management, the procedure for identifying taxpayers (tax agents) with tax risk and classifying them according to the level of tax risk. Now get acquainted with the basic concepts.

**Identified tax risk** - signs of tax offenses identified through the automated program "Determination, analysis and assessment of tax risk" (hereinafter - the Program);

**potential tax risk** - a tax risk that has not been identified but has the conditions for its occurrence;

**tax liability** - the obligation to correctly calculate and timely pay taxes and fees imposed on taxpayers by tax legislation; the obligation of tax agents to correctly calculate, withhold and withhold taxes from taxpayers by tax legislation;

**segmentation of taxpayers** - classification of taxpayers into certain categories depending on the level of risk of non-fulfillment or incomplete fulfillment of tax obligations;

**tax risk** - non-fulfillment or non-payment of tax obligations by the taxpayer (tax agent), which may lead to non-payment or incomplete payment of taxes and fees (hereinafter - taxes) to the budget system probability of failure;

**tax risk level** - a state of risk determined by the probability of occurrence of the risk and its possible consequences;

**tax risk level criteria** - a set of criteria that allows you to assess the risk of non-performance or incomplete fulfillment of tax obligations and then categorize taxpayers (tax agents) according to the level of risk;

**tax risk analysis** - regular use of information available to the tax authorities to identify the circumstances and conditions of the risk, to identify them and to assess the possible consequences of non-compliance with tax legislation.

Through these concepts, data analysis of tax risks is facilitated and helps analysts analyze tax risks. Procedure for tax risk analysis: Tax risk analysis and evaluation of results is carried out using software products. Amount of expenses and income, their dynamics, timely fulfillment of tax obligations, compliance of taxes calculated in the current tax period with the amount of taxes calculated in previous tax periods (decrease, increase). Compliance of the indicators in the information provided to the tax authorities by government agencies and organizations with the indicators in the tax and financial statements of taxpayers. Compliance of tax benefits used with tax legislation. Profitability ratio, which is defined as the ratio of net profit to net income (the amount of income from the sale of goods and services, excluding excise and value added tax), as well as the ratio of net profit to expenses.

## CONCLUSION

Tax risk management is a worldwide phenomenon with growing prominence in the discourse of both revenue authorities and corporate taxpayers. In the Uzbekistan, in-house tax professionals are now subject to unprecedented calls for transparency in terms of their tax risk management strategies and processes. This article discusses the findings of a study of these professionals conducted at a time at which the regulatory environment was becoming significantly more stringent. Overall, the evidence suggests a trend towards a more conservative approach to tax planning generally being adopted. There was also a strong message from the interviewees on the importance of the perceptions around the practice and processes on risk management.

## REFERENCES:

1. D. McBarnet, "Can tax policy survive the avoidance industry? Analysing Strategies in tax and accounting, in the UK and Australia". 11th ICAEW Tax Research Network Conference, Nottingham University Business School, 17-18 September(2001); Spilker et al. fn. 6.
2. B. Porter, "In-house tax department tax managers' response to current legal and environmental changes: an empirical investigation." [1999] BTR 406.
3. J. Freedman, G. Loomer, and J. Vella, "Corporate Tax Risk and Tax Avoidance: New Approaches" [2009] BTR 74.

4. Toshboeva, R.S. (2020). Ecologization Of Uzbekistan Economy: Legal Aspect Of Improvement Of Investment. *Legal Research Journal*, (Special 5).
5. Toshboeva, R.S. (2020). Provision Of Inventory Information About Natural Resources: Problems And Ways Of Their Solution. *Journal Of Legal Research*, 5 (3).
6. Toshboeva, R.S. (2019). Practical Aspects Of Ecological And Legal Education In Secondary Schools. In *Theoretical aspects of jurisprudence and law enforcement issues* (pp. 66-69).
7. Sobirovna, T. R. (2021). Issues of further improvement of water cadastre legislation of Uzbekistan. *ACADEMICIA: An International Multidisciplinary Research Journal*, 11(4), 1241-1253.
8. Mulaydinov, F. (2021). Digital Economy Is A Guarantee Of Government And Society Development. *Ilkogretim Online*, 20(3), 1474-1479
9. Mulaydinov, F. M. (2019). Econometric Modelling of the Innovation Process in Uzbekistan. *Форум молодых ученых*, (3), 35-43.
10. Mulaydinov, F., Kadirova, A., Melibaeva, G., & Akhmadjonov, O. (2020). Advantages of the transition to a digital economy in the innovative development of Uzbekistan. *Journal of Advanced Research in Dynamical and Control Systems*, 12(6), 1226-1232.

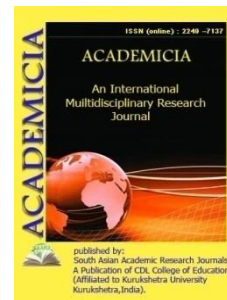

DOI: **10.5958/2249-7137.2021.01948.0**

## THE NEED TO STUDY AVIATION TERMINOLOGY IN UZBEK LANGUAGE

Rano Turaevna Ergashova\*

\*PhD,

Associate Professor of Languages department,  
The Higher Military Aviation School the Republic of UZBEKISTAN  
Email id: Ergashova-91@mail.ru

### ABSTRACT

*Coverage of terminology in Uzbek linguistics on the basis of methods of system-structural analysis is one of the current issues. This has led to the need to conduct research on the formation of terms in Turkish terminology, the criteria for the selection of terms, their effectiveness, compliance and active use of the terms in accordance with the norms of literary language, the structural features of terms. In this sense, the terminology pays special attention to revealing the lexical-semantic, derivational and lexicographic features of aviation terms. This article highlights the scientific significance of the lexical-semantic, lexicographic description of aviation terms, as well as the need to conduct office work, reading and teaching in the Uzbek language.*

**KEYWORDS:** *Aviation, Industry Terms, International, Aeronautics, Terminology, Structure, Semantics, Stages Of Study, Derivation, Term Selection Criteria, Lexicography.*

### I. INTRODUCTION

Thanks to independence, the attention to our native language has increased and all the opportunities for its development have been opened. As a result, radical changes have taken place in the lexicon of various fields, and a number of studies have been conducted on the large-scale study of Uzbek linguistics. Although in Uzbek linguistics today there is scientific research on such terms as zoology, agriculture, botany, medicine, as well as new: tourism, engineering, cybernetics, internet, aviation terms are not specifically covered in linguistic terms and the lexical status of aviation terms is not defined. “We have a great and responsible task ahead of us in the development of the Uzbek language in our country on the basis of modern requirements, to further strengthen its role and prestige as the state language”<sup>1</sup>. On this basis, in the above-

mentioned research there is a need to give a scientific description of linguistic phenomena, to generalize these descriptions and interpretations on the basis of modern methodological criteria, as well as to evaluate them on the basis of innovative methods.

PD-5850 of October 21, 2019 of the President of the Republic of Uzbekistan “On measures to radically increase the prestige and status of the Uzbek language as the state language”, PD-5850 of October 20, 2020 “On measures to further develop the Uzbek language and improve language policy in our country” Adoption of Decree No. 6084 required a new approach to the lexicon, one of the main layers of the Uzbek language, in particular, the terminological lexicon. As a result, there is a need to collect materials on the study of lexicon of a particular field, to reveal and systematize their ontological, onomasiological and grammatical nature, and to create favorable conditions for the formation and development of Uzbek lexicology and terminology.

## II. MAIN PART

In a number of works created by linguists such as I.Kuchkartoev, R.Rasulov, O.Bozorov, R.Safarova, Sh.Iskandarova, B.Kilichev, G.Nematova, Sh.Orifjonova, B.Mengliev, Z.Yunusova, M.Abdiev<sup>2</sup>, the systematic-structural nature of Uzbek language lexicology is revealed. In particular, B. Mengliev’s “Inter-level relations in the integrity of the linguistic system”, A. Sobirov’s “Study of the lexical level of the Uzbek language as a system”, M. Abdiev’s “Systematic study of the Uzbek language. Problems of system analysis of field lexicon” are important to learn terminological system in Uzbek language. They provide a theoretical and practical study of the lexicology of the Uzbek system, as well as its future prospects. In particular, M. Abdiev emphasizes that each word-term in the language enters into various paradigmatic relations in the field of universal and literary speech, and they acquire a systemic character from the highest to the lowest level<sup>3</sup>.

New technical means are also entering the field of aviation on the basis of the latest achievements of science and technology. Fighter, tanker, liner, Airbus, MI-8, SU-35, AES-350, which represent the names of these vehicles, make a worthy contribution to the enrichment of the Uzbek language vocabulary. As an integral part of Uzbek terminology, aviation terminology has also developed and enriched over the years. This required a systematic and structural study of aviation terminology, which is part of Uzbek linguistics. The reason is that the description of the systemic aspect and pragmatic features of lexemes in language as a whole system has brought great achievements not only in linguistics, but also in terminology, and it has become a requirement of the time. In this regard, a comprehensive analysis of the Uzbek language aviation terms in the system-structural direction was aimed at and evaluated as an important area of study in modern Uzbek linguistics. The linguistic role of aviation terms in the Uzbek language, the approach to the nature of speech events on the basis of new methodological criteria in the system-structural direction, the evaluation of existing materials according to innovative principles show their effectiveness in terminology.

The terminology, which is an integral part of Uzbek linguistics, contains a number of problems that need to be addressed in the classification and interpretation of aviation terms, and these problems have not been studied in a systematic way. The use of aviation terms has not been studied on the basis of systems-structural analysis methods. This shows the scientific relevance of the research. It must be acknowledged that in linguistics today, the units of language and speech are separated from each other and studied on the basis of methods of system-structural



analysis. However, in terminology, the issue of polyfunctionality has not been studied in a systematic way, that is, on the basis of a clear system. In particular, in Uzbek terminology, aviation terms are not taken as a special object of study. The study of aviation terms on the basis of the latest achievements of world and Uzbek linguistics is one of the important tasks. In particular, it must be acknowledged that one of the most pressing issues is to identify and recommend the use of industry-appropriate alternatives to our language. This serves as a source for the enrichment of Uzbek terminology. It is also natural that aviation terms serve to clarify the ways, methods and sources of enrichment.

### **III.RESULTS AND DISCUSSIONS**

Introduction into science of new scientifically based words and terms provided for in the Resolution of the Cabinet of Ministers of the Republic of Uzbekistan dated January 29, 2020 No 40 “On measures to organize the activities of the Terms Commission under the Cabinet of Ministers of the Republic of Uzbekistan”; Ensuring uniform and correct application of concepts and terms in draft regulations in accordance with the meaning adopted in the legislation, excluding the possibility of different interpretations; ensuring compliance with the rules and norms of literary language, as well as legal, technical and other special rules in the draft regulations; editing inconsistencies that may arise due to the rules of other languages without prejudice to the norms of normative legal acts; The main task is to study the legal problems of the introduction of new terms in the legislation and their application in practice, to determine the directions of development of legal regulation of relations in this area. A number of the tasks outlined above also apply to aviation terminology.

The changing and active layer of the lexicon of the modern Uzbek language is a set of words related to science, technology and production - scientific and technical terminology. Units of language terminological systems are characterized by sectoral specificity, as well as common features. In particular, the terms used in the socio-humanitarian, economic-political, natural, exact sciences, technical and technological fields are distinguished by special features.

The extrolinguistic development of terminology, the deep penetration of science and technology into human activity, poses a number of important tasks for our linguists.

Extensive research has been conducted in this area in recent decades. Nevertheless, there is still debate about the place of the general theory of terminology in the sciences. According to UNESCO, there are 6,000 languages in the world, while advanced scientific terms are available in only 60 languages and cover about 300 professional fields<sup>4</sup>.

The International Civil Aviation Organization (ICAO) has adopted six official languages. These are French, Spanish, English, Russian, Arabic and Chinese. However, representatives of the Turkic-speaking nation have to learn and communicate in the above-mentioned languages in order to work in this field. One of the current issues is that the Turkic-speaking peoples should submit their proposals to the ICAO on the adoption of the Turkish language as an international aviation standard. To this end, we believe that the issue should be brought to the attention of the international community with the support of the Council of Turkic Speaking States.

### **IV. CONCLUSION**

Today, the problems that arise in the translation of aviation terms in Uzbek terminology are waiting to be resolved. In the study, the terms encountered in this field were analyzed, and the

lexical-semantic, structural-grammatical features of aviation terms in the case of comparison in three languages were studied.

The field of aviation is characterized by the fact that people are relatively young as a type of professional activity and a separate branch of knowledge, so its development inevitably requires the development of field terminology that professional and scientific activities in a particular field. In addition, the terms are distinguished by the characterization of the literary-philosophical literature, which forms the practical term tools and methods in presenting new, specific concepts.

#### REFERENCES:

1. Holiday greetings of the President of the Republic of Uzbekistan Sh.M.Mirziyoev to the people of Uzbekistan on the occasion of the Uzbek language holiday // People's speech, October 20, 2020, - № 221-222 (7723-7724).
2. Quchqortoev I. The meaning of the word and its valence. – Tashkent, 1977. – 168 p .
3. Rasulov R. Fundamentals of Uzbek language system lexicology. – T .: Teacher, 1995. – 128 p.
4. Bozorov O. Leveling in Uzbek language: Philol. . doct. .. diss. abs. – T .: 1997. – 21 p.
5. Safarova R. Hyponymy in the Uzbek language. Abs. dis ... cand. filol. science. – Tashkent, 1999. – 25 p.
6. Iskandarova Sh. Problems of studying vocabulary on the basis of semantic field. – Tashkent: Fan, 1998. – P.136.
7. Qilichev B. Paronymy in Uzbek language: Philol. ... diss. abs. –Tashkent, 1997. – 19 p.
8. Nematova G. Lexemes of plant names in Uzbek language: system and artistic use: Philol. diss. abs. – Tashkent, 1998. –22 p.
9. Orifjonova Sh. Lexical graduonymy in Uzbek language: Philol. diss. abs. – Tashkent, 1996. – 19 p.
10. Mengliev B. Inter layer relations in the integrity of the linguistic system: Philol. doct. ... diss. – Tashkent, 2002. – 248 p.
11. Yunusova Z. The structure and development of the lexical microsystem in the Uzbek language: Philol. diss. abs. –Tashkent, 2004. – 130 p.
12. Abdiev M. System analysis of sectoral lexicon (on the basis of materials of professional names of Samarkand region): Philol. doct ... diss. abs. – Tashkent, 2005. – 25 p.
13. Abdiev M. Problems of system analysis of field lexicon. –Tashkent: Meros, 2004. – P.107.
14. Superanskaya A.V., Podolskaya N.V., Vasilyeva N.V. General terminology. – M.: Nauka, 1989 .– P. 4.

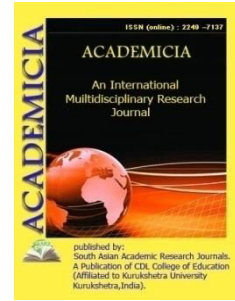
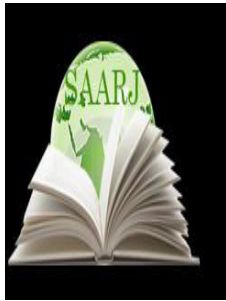

DOI: **10.5958/2249-7137.2021.01949.2**

## COTTON STALK REMOVER

**Maxammadjon Xabibullayevich Mamadaliyev\***; **Mirkomil Mirzatolibovich Halilov\*\***;  
**Muxammadjon Abdumomin ogli Rozimatov\*\*\***;  
**Xushnadbek Nurmuxammad ogli Raxmonov\*\*\***

\*Associate Professor,  
 Andijan institute of agriculture and agro technology,  
 UZBEKISTAN

\*\*Associate Professor,  
 Andijan institute of Mechanical Engineering,  
 UZBEKISTAN

\*\*\*Assistant,  
 Andijan institute of Mechanical Engineering,  
 UZBEKISTAN

Email id: ruzimatov1991@inbox.ru

### ABSTRACT

*It is known that on farms, winter wheat is planted between the rows of harvested cotton fields before the cotton stalks are removed, so that the fields are cultivated until the seedlings are fully germinated. techniques are not included. This is because they cause great damage to the germination and development of young seedlings and reduce yields. The cotton stalks left in the fields are harvested after the ground is completely frozen. However, as a result of their roots remaining in the soil, they develop fusarium wilt and spread to other areas. Therefore, it is important to develop a machine to completely uproot the cotton stalks in the wheat fields[1].*

**KEYWORDS:** *Tractor, Generator, Cotton Stalks, Cotton Picking Machine, Disc Mechanism*

### INTRODUCTION

The only requirement for the use of such agricultural technology is to preserve the emerged young shoots of wheat from mechanical damage that occurs during the subsequent uprooting of cotton stalks and their harvesting.

Therefore, the innovators and technical workers of the Republic are faced with the task of developing and introducing in cotton-growing farms a simple and reliable technical means for mechanical harvesting of cotton stalks, while preserving mature wheat crops[2].

### **Materials**

The objective of the proposed development is to create a mechanized device for removing cotton stalks that is simple in design and reliable in operation, while it must meet the following requirements:

- The action of the stem suppression mechanism should be based on the method of cutting, not uprooting;
- Provide a mechanism for transporting cut stems with the formation of a bunch;
- the machine must ensure the processing of the aisle from both sides;
- to preserve as much as possible and not to damage the grown beds of wheat.

Since the problem of the proposed device is solved as follows.

In a device for removing stalks of cotton, containing a frame mounted on support wheels with a stalk cutting mechanism located on it, a pulling-transporting working body and a beam shaper, the stalk cutting mechanism is made in the form of a fast-revolving disk knife installed in the nose of the frame at an angle in the direction of travel of the device, the pulling-transporting working body is located on the frame two pairs of cone-shaped rollers rotating towards each other with a profiled surface, while one end of the roller is mounted on a sliding bearing, and the other is fixed on a worm wheel coupled with a worm, cinematically interconnected with the axis of the support wheels, and the beam former is made in the form of a hollow drum with versatile winding of blades[3].

The proposed device for removing stalks of cotton (Fig. 1) contains a spatial welded frame 1, consisting of longitudinal beams 2, reinforced with transverse crossbars 3, vertical struts 4 and scarves 5. The frame rests on two rear 6 and one front 7 wheels. In the front part of the frame, a curved U-shaped bracket 8 with a pulling hook 9 is welded to the longitudinal beams 2 for aggregated with a tractor (not shown in the figure) and a swivel sub frame 11 is located on the hinge hinges 10, on which a quickly revolving mechanism 12 is located on both sides with a circular knife 13, fixed with a cap gull 14. The cutting mechanism is fixed to the dressing room by means of bandage connectors 15, and feeding is carried out through a flexible electrically insulated cable 16 connected to a DC generator from a tractor (not shown in the figure). On the frame at a distance of 6, equal to the width of the row spacing of cotton, there are two pairs of pulling-transporting working bodies, each of which includes cones of the bearing rollers 17 with a profiled surface rotating towards each other, while the lower end of the roller is installed on the field by a reducer 19, which contains a common worm shaft with a left turnover 20 and right turnover 21 worm and mating, respectively, with a left turnover 22 and right turnover 23 worm wheel. A kinematic sprocket 24 is fixed on the worm shaft, interconnected through a chain transmission 25 with a double sprocket 26 mounted on the axle 27 of the rear wheels 6. From the side of the worm gear 19 on the frame 1 in a vertical plane above the rear wheels, a beam former 28 is installed, made in the form of a hollow drum with versatile winding of blades 29, the

rotation of which is carried out by means of a double sprocket 25, a chain transmission 30 and a driven sprocket 31. On the unloading side, a slide 32 is installed on the frame.

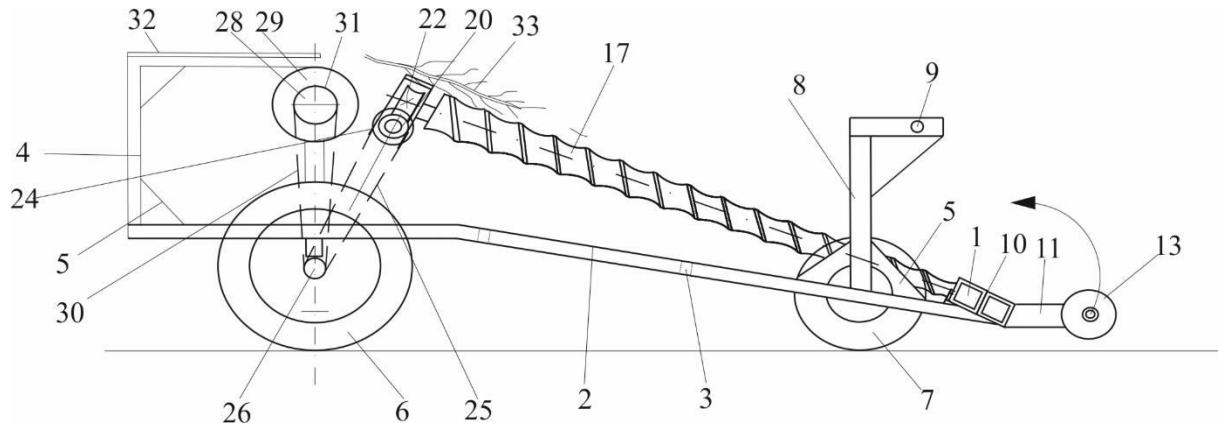

**Figure1. Structural diagram of a device for removing stalks of cotton.**

The device for removing stalks of cotton works as follows.

Before starting work, the swivel subframe 11 is installed in a vertical position and two fast revolving cutting mechanisms 12 are mounted on it in a mirror image, they are checked at idle, under connecting to a DC or AC generator generated by the tractor. Then the disc knives 13 are installed and secured with the union nut 14 and the check is carried out again. After making sure that the electrical part is working, the precursor is lowered into the working position and, through the traction hook 9, is aggregated with the MTZ-80 tractor[4].

## Results

When passing along a row spacing of  $h = 90$  cm and bypassed young shoots of wheat on the slopes of the beds, circular knives 13, set at an angle to the cotton stalk, cut over the root part of the stem 33 without damaging the wheat growth. The cut off stems come between the cone-shaped rollers 17 rotating towards each other, which pull the stems and simultaneously transport them in the direction of the beam former 28. In this case, cotton stalks from dried roller pairs, in the form of compacted bundles, enter the former 28 and in the process of rotation of the latter are combined into a larger bundle (sheaf) and removed through the middle of the slide 32. Here it can be tied with twine and stored as fuel.

The developed kinematic diagram of the device ensures the operation of all cone-shaped rollers and the beam former due to the rotation of the support wheels 6.

The use of a quickly revolving disc mechanism for cutting cotton stalks at the level of the soil surface does not damage the germinated wheat cover, which was typical for mechanical uprooting. This method of removing stems is especially important when surface freezing of the soil, in which uprooting is impossible.

The serial production of the bottom device will allow preserving the winter sowing of wheat and will provide the local population with cheap biological fuel and is an economic help for the population.

However, we can also cite the following information. The fields are cleared of cotton stalks by hand. On some farms, this process is done by using cotton stalks to grind them and scatter them



on the field. This leaves stems 15-20 cm above the field surface. As a result, the disease mentioned above can spread to and damage wheatgrass[5].

It should be noted that the complete removal of cotton stalks from the fields with their roots will ensure a certain level of fuel demand of the population. Using such a machine reduces the cost of removing the stalks by 30% and the use of manual labor by 90%.[6].

A design scheme has been developed for a machine that can completely uproot cotton stalks in wheat fields. During the operation of this machine, both sides of the cotton stalks are cut at a distance of 4-5 cm with disc knives, and the cotton stalks are pulled out using a drum equipped with special clamps. As a result, the roots of wheat seedlings are pulled out of the cotton stalks without transplanting. This saves resources and increases productivity.

## CONCLUSION

Based on the above, based on the analysis of the literature and research, a design scheme was developed for a machine that can completely uproot cotton stalks in wheat fields (see Figure 2). During the operation of this machine, the two sides of the cotton stalks are cut with disc knives at a distance of 4-5 cm, and the cotton stalks are pulled out using a drum equipped with special clamps. As a result, the roots of wheat seedlings are pulled out of the cotton stalks without transplanting. This saves resources and increases productivity.



*Figure 2. A model of a cotton picking machine.*

The proposed machine is aggregated with 1-2 class tractors and is called by us as a resource-saving machine used for clearing wheat fields from cotton stalks, and based on the above, this work is aimed at developing and justifying its parameters. .

## REFERENCES

1. M.Shoumarova, T.Abdullaev Agricultural machines. - Tashkent. The Teacher, 2002.
2. Kpenin N.I., Sakun V.A. Agricultural and reclamation machines. Moscow, Agropromizdat, 1980.
3. Listopad G.E. et al. Agricultural and reclamation machines. Moscow, Gosizdat, 1986.
4. Karpenko A.N., Khalansky V.M. Agricultural machines Moscow, "Kolos", 1983.



5. M.A.Rzimatov. IMPROVEMENT OF OIL FILTER ELEMENTS. Universum Technical Sciences No. 2(83), Part 1, February 25, 2021 <https://7universum.com/ru/tech/archive/item/11321>
6. M.A.Ro'zimatov. ENSURING RELIABLE OPERATION OF THE COMPRESSION RING. Universum Technical Sciences No. 3(84), March 25, 2021 <https://7universum.com/ru/tech/archive/item/11384>
7. M.A.Ro'zimatov. IMPROVING ECOLOGY AND ENVIRONMENTAL PROTECTION (ON THE EXAMPLE OF THE REPUBLIC OF UZBEKISTAN). Universum Technical Sciences No. 5(86), May 25, 2021 <https://7universum.com/ru/tech/archive/item/11702>

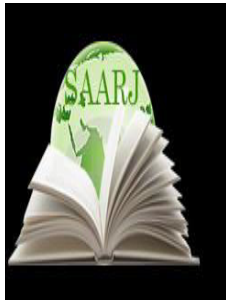

**ACADEMICIA**  
**An International  
 Multidisciplinary  
 Research Journal**  
 (Double Blind Refereed & Peer Reviewed Journal)

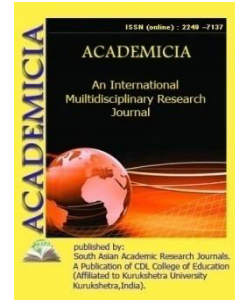

**DOI: 10.5958/2249-7137.2021.01950.9**

**A NEW APPROACH TO THE TREATMENT OF CHRONIC  
 CONSTIPATION AND DIAGNOSED DYSBACTERIOSIS IN CHILDREN  
 WITH DOLICHOSIGMA**

**Isroilov M.S\***

\*Assistant,  
 Department of “Operative Surgery and Topographic Anatomy”,  
 Fergana Public Health Medical Institute,  
 UZBEKISTAN

**ABSTRACT**

*Symptoms of chronic constipation in children with dolichosigma are based on the results of studies conducted by some scientists in recent years (N.I. Lyonyushkin 1990, A.S.Sulaymonov 1993, Rivkin V.A 2012, G.N.Sheligin 2012) and cited data that these diseases are detected in 30-40% of children aged 2-11 years. In addition (Lesnyak S.V., Evtukhova L.N., Shimchuk L.F. 1998, Bondarenko V.M. 2003) in the study of the microflora of fecal analysis of children with dolichosigma they found a sharp decrease in the number of bifidobacteria and lactobacilli, pathogens; they have been shown to cause dysbacteriosis as a result of an increase in the number of microflora (Escherichia coli, Proteus, Streptococcus, Staphylococcus, and Bacteroids), as well as changes in clinophysiological conditions in some sick children.*

**KEYWORDS:** *Escherichia Coli, Proteus, Streptococcus, Staphylococcus, Bacteroids, Colostasis, Morph Functional Changes, Constipation, Dysbacteriosis,*

**INTRODUCTION**

Y.N.Nishanov 1996, B.A.Shindaryov 1998, G.A.Onishchenko 2002 Dysbacteriosis was caused by changes in the number and quality of the microflora of the small intestine as a result of partial or complete removal of the colon. To overcome this dysbacteriosis, experimental animals were shown to be eliminated by injecting bifidobacteria and lactobacilli into the digestive system through a probe, and the gastrointestinal tract evacuator and absorption function was restored in 15–20 days.

Untimely evacuation of feces in the sigmoid part of the colon leads to its excessive hardening, expansion and elongation of this part, ie, the development of dolichosigma (E.G. Tsimbalova, A.S. Potapov 2002).

### **THE MAIN FINDINGS AND RESULTS**

In recent years, various theoretical views on the origin and course of dolichosigma have been observed among scientists (Clayden Q., Keshigar 2003y, Sheligin Yu.N 2012). In addition to the data of the above scientists, some gastroenterologists link the symptoms of constipation in dolichosigma to the following factors:found that the lack of large gluten in the diet consumed causes hypodynamics, stressful situations and chronic colitis and dysbacteriosis in the colon (BiezinA.P. 1994, Dvoryakovsky S.Y. 2001).

According to some researchers, as a result of constipation (colostasis) among children and adolescents with long-term constipation, their physical development and anthropometric indicators are clearly lagging behind (Y.N. Nishanov, J.T. Mamasaidov, M.S. Isroilov 2019).

Thus, in recent years, studies of articles and monographs published by researchers have shown that constipation is caused by dolichosigma in children, and surgical and conservative methods are used to treat it.

However, due to differences of opinion among some scientists, morphofunctional changes in the sigmoid colon in children currently suffering from dolichosigma; as well as the timely detection of dysbacteriosis, as well as the delay in physical development due to this disease and a new approach to the treatment of the pathological process have become a pressing problem facing pediatric surgeons today.

### **PURPOSE**

The use of new methods of conservative treatment of morphofunctional changes, constipation, dysbacteriosis and symptoms of physical retardation caused by dolichosigma.

### **METHODS OF STUDY**

Anamnesis collection, irrigography, irrigoscopy, endoscopy, colonoscopy, histomorphological, bacteriological, anthropometric methods and clinical-biochemical examinations.

### **OBJECT OF RESEARCH AND RESULTS**

To identify and study dolichosigma in children, it was studied in 150 patients (92 boys, 58 girls) aged 0-18 years in the surgical department of the Children's Multidisciplinary Medical Center of Fergana region during 2018-2021.

Dolichosigma is the elongation and dilation of the sigmoid colon. The terms "dolichocoln" and "dolichosigma" are often used by clinicians and radiologists, but do not define the exact boundaries of the pathology. K.N.Bossovskiy 1989).

MS Hechinashvili (1957), who studied sigmoid bowel changes in infants, divided it into the following types: "S" simon (53%), single-loop (27.8%), double-loop (57%) and multi-loop (9.9%). If previously dolichosigma was considered a pathogenetic manifestation of chronic constipation, now the question is whether to consider it as a congenital defect of development. In recent years, 25% of more than 1,000 children with chronic constipation and recurrent abdominal pain have been diagnosed with dolichosigma as a result of dynamic observations (A.V. Makarov,

Z.A. Trafimova, and N.P. Kush 1982). Thus, on the one hand, sigmoid colon elongation is considered normal in healthy children; while on the other hand, dolichosigma is associated with recurrent abdominal pain and chronic constipation. At the clinic, parental complaints mainly consist of chronic constipation or recurrent abdominal pain in the child. Chronic constipation is caused by a disorder of sigmoid intestinal motility and occurs in most children after 60% of their lives have been switched to artificial feeding, and in 40% of cases it occurs between the ages of 3-6 years. Abdominal pain is caused by stagnation of intestinal mixtures, flatulence, as well as twisted and tangled loops of excess loops, and scarring of the uterus, which occurs at the age of 5-7 years. Sometimes the pain passes with vomiting. The disease is clinically distinguished in 3 stages: compensatory, sub-compensatory, and decompensated.

Based on the above data on dolichosigma and our study of sick children, our main plan was to eliminate the causes and consequences of this disease in all respects, namely, morphofunctional changes in the sigmoid colon, constipation and dysbacteriosis. For this purpose, 150 children (92 boys, 58 girls) with dolichosigma were thoroughly examined and treated in the Department of Pediatric Surgery of the Fergana Regional Multidisciplinary Medical Center for 2018-2021. Of these, 0-5 years - 55 (36.6%), 6-10 years - 58 (38.6%), 11-15 years - 27 (18%), 16-18 years - 10 (6, 6%) people. After the patient was admitted to the hospital, symptomatic signs (abdominal rest, abdominal pain, signs of constipation, weakness, loss of appetite, and anemia) were identified, depending on the age of the children and accumulated from them. X-ray examinations (irrigography and irrigoscopy) were performed in such sick children. X-ray images were taken in two views (anterior and lateral), after which the colon was cleared of contrast. Examination of radiographs showed an elongation and dilation of the S-shaped intestine, the appearance of additional loops (up to 2-3), no change in the shape and position of the abdomen, flattening of the colon gastras, as well as single-loop - 34.6%, double-loop - 49.1 %, three-loop -13.4% and multi-loop -2.9% were found to have symptoms.

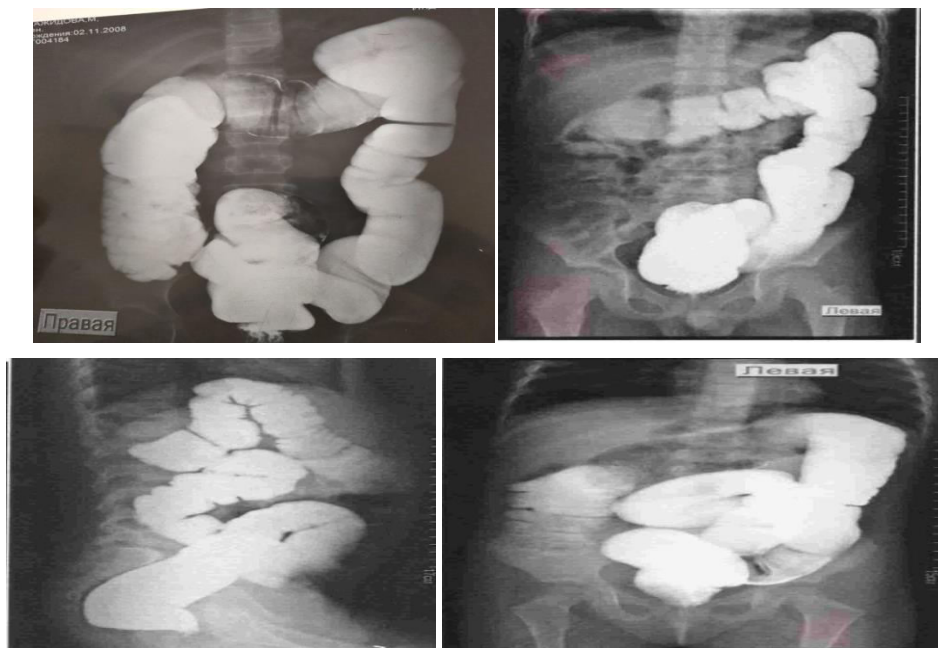

Clinical and biochemical analysis of blood showed the following cases: normochromanemia in 50.6% of patients, erythrocyte depletion in 39% of patients, leukopenia in 35% of patients,

hypoproteinemia and dysprotenemia in 12% of patients. Toxic hepatitis was observed in 8 patients due to chronic stool retention in the colon.

Bacteriological laboratory examination of the stool of 32 (21.3%) of the studied patients revealed the presence of dysbacteriosis in 28 (87.5%). We can also consider this on the basis of the table (Table 1,2,3).

TABLE №1

№	Micro-organisms	Normal	In the patient
1.	Bifidobacteria	$10^{10}$	$10^2$
2.	Lactobacterin	$10^7$	$10^1$
3.	Enterococci	$10^5$	$10^8$
4.	Staphylococcus	-	$10^2$
5.	Streptococcus	$10^1$	$10^4$
6.	In fungal candidiasis	$10^3$	$10^6$
7.	Protey	$10^3$	$10^6$
8.	Klebsiella	$10^3$	$10^7$

TABLE №2

№	Micro-organisms	Normal	In the patient
1.	Bifidobacteria	$10^{10}$	$10^1$
2.	Lactobacterin	$10^7$	$10^3$
3.	Enterococci	$10^5$	$10^5$
4.	Staphylococcus	-	$10^1$
5.	Streptococcus	$10^1$	-
6.	In fungal candidiasis	$10^3$	$10^5$
7.	Protey	$10^3$	$10^3$
8.	Klebsiella	$10^3$	$10^6$

TABLE №3

№	Micro-organisms	Normal	In the patient
1.	Bifidobacteria	$10^{10}$	$10^3$
2.	Lactobacterin	$10^7$	$10^2$
3.	Enterococci	$10^5$	$10^5$
4.	Staphylococcus	-	-
5.	Streptococcus	$10^1$	$10^3$
6.	In fungal candidiasis	$10^3$	$10^4$
7.	Protey	$10^3$	$10^4$
8.	Klebsiella	$10^3$	-

As can be seen from the above tables, the analysis showed that the number of Escherichia coli, bacteroids, staphylococci and klebsiella increased compared to the norm, while the number of bifidobacteria and lactobacilli decreased compared to the norm.

The histostructure of the mucosa by biopsy was studied, along with the study of macroscopic changes in the sigmoid colon mucosa by colonoscopy of 18 of these patients. According to the results of the study, the proliferation of hemispherical folds in the mucosa, the absence of cylindrical epithelial cells in some areas, a decrease in the number of capillary cells, a decrease



in the number of subcortical basal vessels (capillaries), obvious signs of dilatation, thinning of the mucous membrane relative to the norm, atrophy of the fibers of the mucous membrane, mucous membrane and muscle layers (circular and longitudinal) were observed.

Picture 1



Picture 2



Picture 3



Picture 4

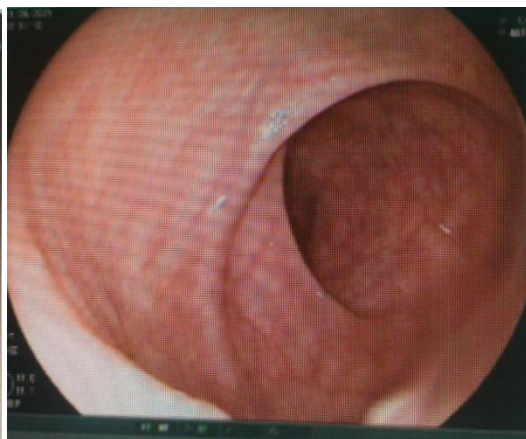

All of the above changes indicate that there are factors that negatively affect the physical development of children with dolichosigma. As a result, it was observed that the lag in anthropometric indicators varied in patients of different ages. When analyzing the height of patients with dolichosigma: in 63 (42.1%) of the 150 patients studied, they were behind the norm, in boys - 32 (50.7%), in girls - 31 (49.2%), by weight Out of 150 patients, 106 (70.6%) were left behind, 66 in boys (62.2%) and 40 (37.7%) in girls.

In the conservative treatment of dolichosigma, regimen and diet also play a significant role in the prevention of defecation disorders. There are also inpatient physiotherapy treatments, vitamin therapy, abdominal massage and treatment in sanatoriums. We used a special device (catheter) to correct dysbacteriosis detected in dolichosigma disease. After the cleansing enema, a special device (catheter) was inserted into the rectum through the anus to the designated place and after making sure that it reached the sigmoid colon, bifidobacterin and lactobacillin were dissolved in warm distilled water and the dissolved mixture was injected through the catheter into the sigmoid colon (900 in the morning). After 10-12 hours, these patients were again injected through the



anus with a special device (catheter) into the rectum, and depending on the age of the patient were sent 10-15 ml of pumpkin oil with a syringe. The above treatments were performed in each patient for 10 days. After the treatment, the patient's stool was examined in a bacteriological laboratory and positive results were obtained. When analyzing the feces of patients, it was observed that the number of bifidobacteria and lactobacilli was restored (increased) and the number of pathogenic microflora decreased sharply.

Based on the results obtained, it is advisable to carry out the above procedures to eliminate the morphofunctional changes of the colon caused by dolichosigma disease in children, constipation and the observed symptoms of dysbacteriosis.

### **CONCLUSIONS**

1. Anthropometric indicators of physical development were studied for the first time in a comprehensive analysis of the complications of dolichosigma disease in the sigmoid colon of 150 patients studied.
2. In 18 of the 150 patients treated, histomorphological examination of the biopsy obtained during colonoscopy revealed inflammation, destructive and atrophic changes in the mucous, submucosal and muscular layers of the sigmoid colon. By applying a new method of conservative treatment, it was possible to eliminate the changes in these identified pathological processes.
3. Based on the dynamic analysis of clinical biochemical and bacteriological examinations of the studied patients for the first time, 28 patients were able to restore morphofunctional changes and eliminate dysbacteriosis by transferring bifidobacteria and lactobacilli to the inner wall of the sigmoid colon through a special device (catheter).

### **REFERENCES**

1. A.S.Sulaymonov, A.I.Lenyoshkin, A.J.Hamroev, J.O.Otaqulov, B.M.Qilichev. Pediatric coloproctology. – Tashkent, 1999.– pp. 195-199
2. X.A.Akilov, F.X.Saidov, N.A.Xojimuxamedova. Diagnosis and treatment of chronic colostasis with dolichosigma in children. – Tashkent, 2013.
3. E.G. Tsimbalova. Chronic constipation in children. – Moscow, 2013.
4. V.L. Rivkin. Chronic constipation.– Moscow, 2013.
5. N.L. Pakhomovskaya, A.S. Potapov. Rational therapy for chronic constipation. – Moscow, 2013.
6. R.A. Bashirov. Technique of performing colonoscopy with dolichosigma. – Moscow, 2018.

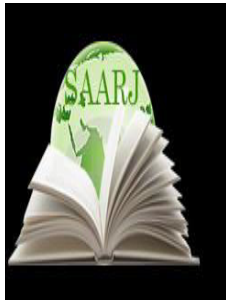

**ACADEMICIA**  
**An International**  
**Multidisciplinary**  
**Research Journal**  
 (Double Blind Refereed & Peer Reviewed Journal)

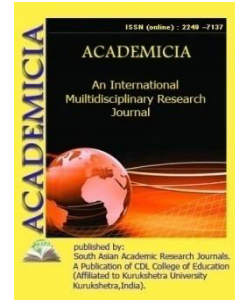

**DOI: 10.5958/2249-7137.2021.01951.0**

## ANALYSIS OF ACCELERATION SLIP REGULATION SYSTEM USED IN MODERN CARS

**Makhammadjon Alijon ogli Qobulov\***; **Akhror Abduqohhorovich Abdurakhimov\*\***

\*Assistant,

Department Of Ground Transport Systems And,  
 Their Exploitation At The Fergana Polytechnic Institute,  
 UZBEKISTAN

\*\*Assistant,

Department Of Ground Transport Systems And,  
 Their Exploitation At The Fergana Polytechnic Institute,  
 UZBEKISTAB

### ABSTRACT

*In this work discusses the structure of the acceleration slip regulation system used in modern cars and the principle of its operation. The same sensors are used for the anti-lock braking system (ABS) at the same time to prevent the car's wheels from getting locked in the brake pad [1]. These sensors send a signal to the control unit of the system that the steering wheel has started to crack. The electronic control unit automatically performs a function similar to the process used to reduce engine power and depress the accelerator pedal. That is, the rattling wheels brake automatically from time to time.*

**KEYWORDS:** *Transport Vehicles, Technical Exploitation, Technical Condition, Control.*

### INTRODUCTION

The Acceleration Slip Regulation (ASR) is also known as the Traction Control Regulation (TCR) and is part of the Electronic Stability Program (ESP). It is also one of the most active car safety systems. Regardless of how the road surface is paved during driving (smooth and soft surfaces i.e. ice, snow, water, gravel, wet piled stones and low friction roads) and how the accelerator pedal is depressed by the driver is a system designed to prevent the wheels from slipping, i.e. shattering. As soon as this system works, the engine's power consumption is reduced by adjusting the speed of the leading wheels. The system has its own special elements, each of which is equipped with wheel sensors. These sensors send information about the speed of

rotation of each wheel to the electronic control system of the system. The same sensors are used for the anti-lock braking system (ABS) at the same time to prevent the car's wheels from getting locked in the brake pad [1]. These sensors send a signal to the control unit of the system that the steering wheel has started to crack. The electronic control unit automatically performs a function similar to the process used to reduce engine power and depress the accelerator pedal. That is, the rattling wheels brake automatically from time to time. As a result, the system elements ensure that the car gradually gets out of difficult road conditions. This process is associated with changes in the information signals coming from the car's wheel sensors. The driver can see the operation of this system through the flashing ESP, ABS and ASR lights on the control panel. In addition, the driver can turn the ESP and ASR systems on and off at will (manually) using the buttons. If the weather is good and the roads are dry, the driver can turn off the system and, if necessary, turn on the system [2].

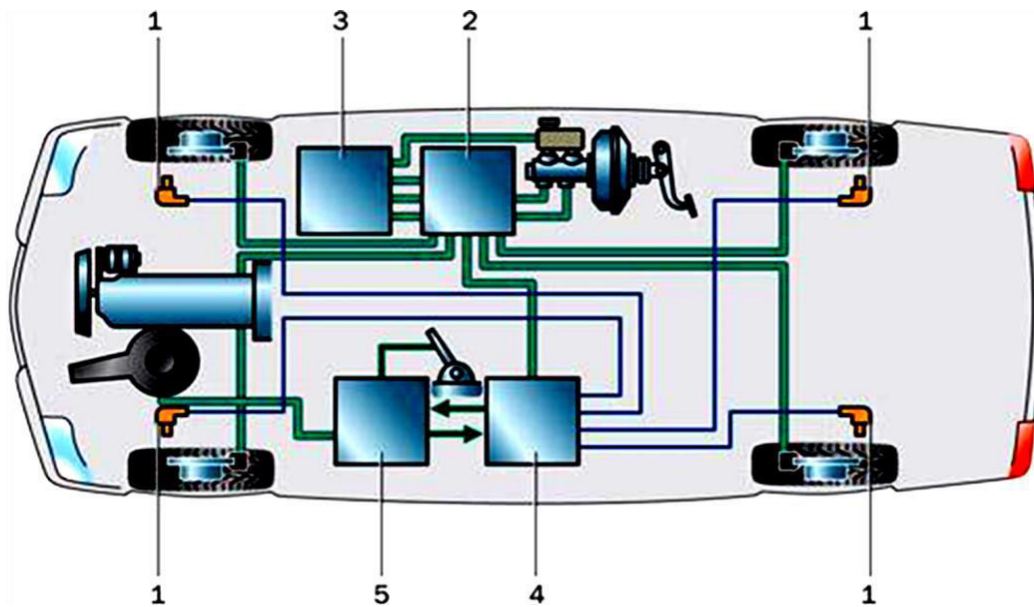

Figure 1. Complex scheme of ABS / ASR system in a car.

1-wheel speed sensor, 2-ABS modulator, 3-ASR modulator, 4-ABS electronic control unit, 5-ASR electronic control unit.

This system consists of the following components:

Wheel speed sensor. These wheel sensors are mounted on each moving wheel and send the following information about the speed of rotation of the wheels while the car is moving to the electronic unit of the system at a rate of 0.025 per second, for example:

Rotation speed and wheel angle acceleration;

- Vehicle speed;
- Lead wheel splitting;
- Traffic status.

It should be noted that these sensors are used not only to measure the angular velocity of the wheels, but also to compare the remaining data, such as the speed of rotation and the movement of the leading wheels.

Electronic control unit. Currently, a single electronic control unit is used for ABS and ASR systems, through which each transmitted variable data, in the event of a catastrophe, the ASR system unit activates the actuators, and the system's electronic control unit with differential will start working in a continuous connection.

Executive mechanisms. The actuators work by controlling the engine and activating the brakes through a group of additional solenoid valves connected to the hydraulic modulators in the ABS system when the vehicle changes direction abruptly and when some of the wheels slip.

### Methods

The principle of operation of the ASR system is very simple, with the help of wheel sensors continuously sends information about the speed of rotation of the wheel to the electronic control unit of the ASR system to prevent accidents while driving, and the necessary measures using the electronic block is done. Typically, a sudden increase in wheel speed can increase the ability of the wheel to crack, as well as change the direction of movement of the vehicle.



Figure 2. Probable motion of a vehicle with a high-speed ASR system (blue) and a vehicle without (white).

In fact, based on the analysis adopted by the electronic control unit to prevent the accident, the orders given to the executive mechanisms based on safety requirements depend on the speed of the vehicle:

- Braking on the leading wheels at speeds of 40-80 km/h;
- Is achieved by reducing the torque by the engine at speeds above 40-80 km/h [3].

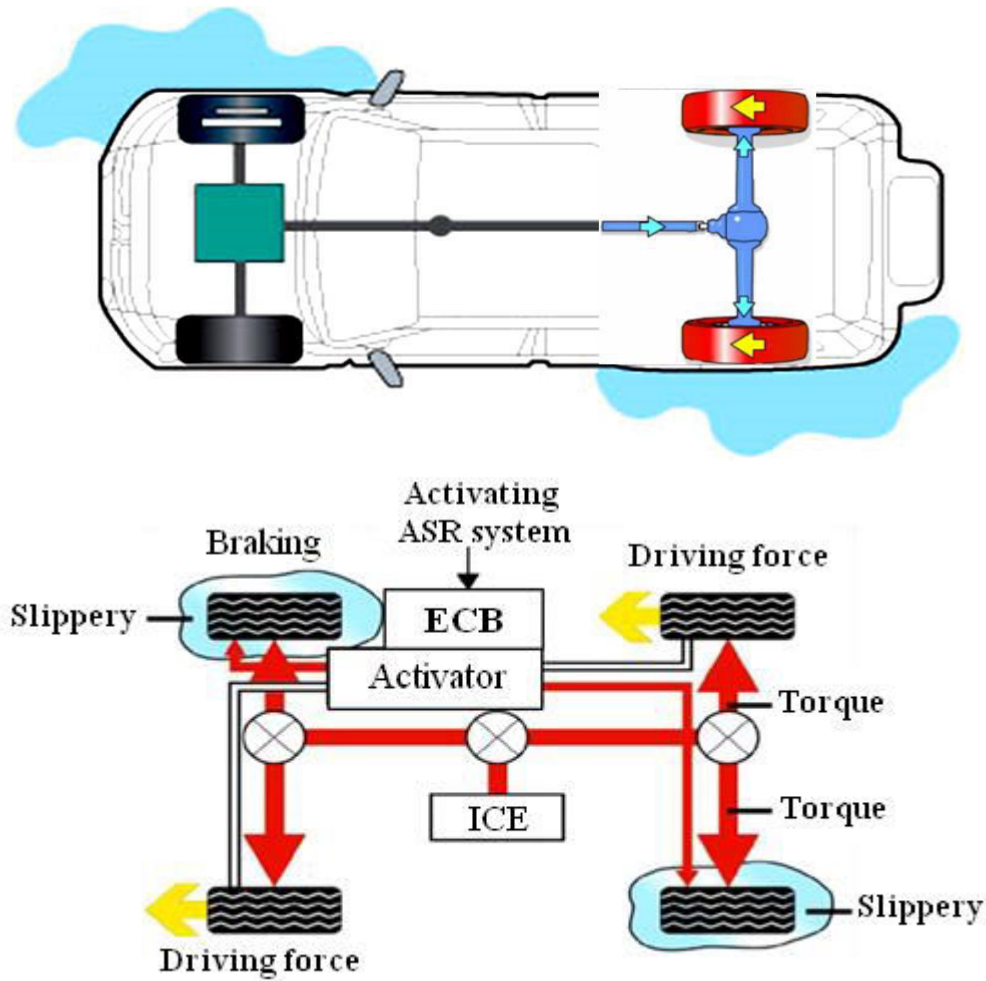

Figure 3. The principle of operation of the ASR system.

Also, both methods can be used at the same time. For example, the torque applied to the braking wheels is based on a systematic process, such as the ABS system. In this process, the brake fluid creates a short brake on the brake wheel cylinders by the ASR module, thus the system controls the situation as much as possible and ensures that the car gradually exits the critical position, thus the leading wheels on the other side create a shift does.

Analysis. The speed and acceleration values of the power-generating wheels are compared with those of the non-power-producing wheels (Figure 4).

Reducing torque can be achieved in different ways with the engine, and the difference is that these systems from different manufacturers can often work as follows:

- Throttle valve control;
- Changing the timing of firing angles;
- Temporarily extinguish spark plugs on one or more cylinders;
- Turn off the fuel injector for one or more cylinders.



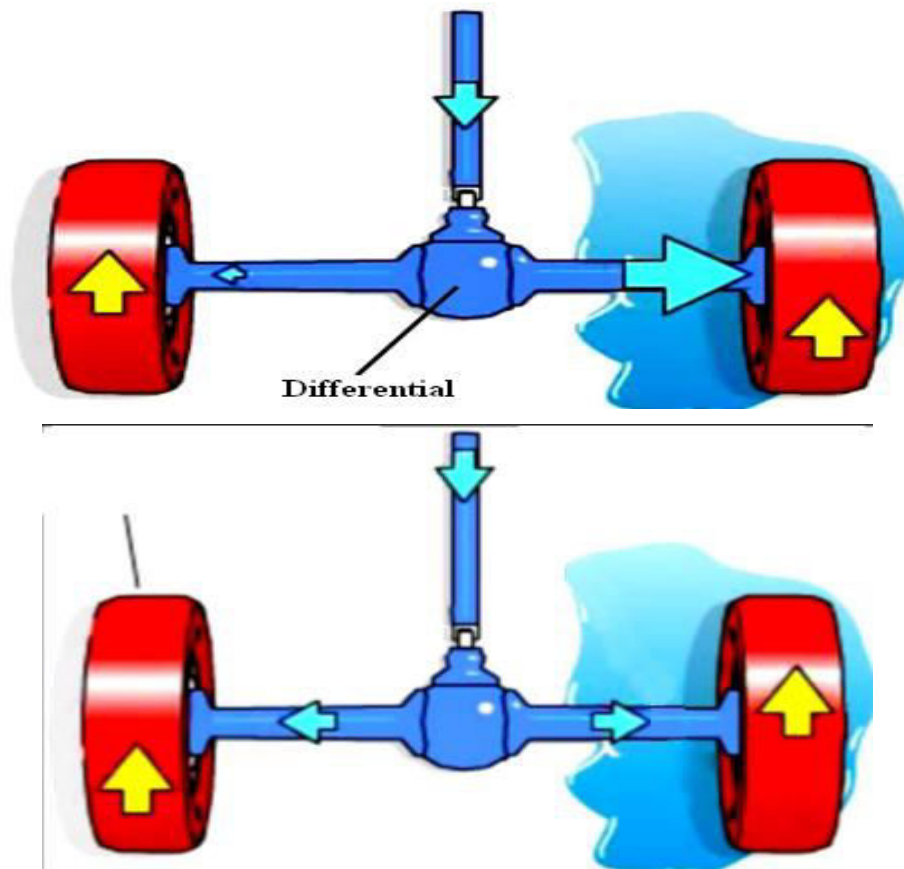

Figure 4. The process of distributing the traction force applied to the leading wheels of the ASR system

## DISCUSSION

This system is one of the systems designed to improve the characteristics of the vehicle, aimed at preventing (reducing the likelihood of its occurrence), creating an active safety system for the structural safety of vehicles. Active safety occurs when the driver is able to change the nature of the movement of the vehicle (corresponding to the initial period of the accident).

## CONCLUSION

Therefore, the purpose of this system is to maintain the balance of the car, which serves to reduce and prevent road accidents caused by snow, rain and frost, as a result of which the active safety of the car is ensured.

## REFERENCES

1. Xusanjonov, A., Qobulov, M., & Abdubannopov, A. (2021). Analysis of Structures Used in Noise Suppression Devices in Vehicles. *Academic research in educational sciences*, 2(3).
2. S. Khodjayev, A. Xusanjonov, & B. Botirov (2021). Increasing Power Efficiency Produced By Domestic Engine Engine Using Hybrid Engine Vehicles And Harmful To The Environment. *Scientific progress*, 2 (1), 1523-1530.



3. Xodjayev, S., Xusanjonov, A., & Botirov, B. (2021). Transport Vositalari Dvigatellarida Dimetilefir Yoqilg'isidan Foydalanish. *Scientific progress*, 2(1), 1531-1535.
4. Nagai, M. The perspectives of research for enhancing active safety based on advanced control technology. *Veh. Syst. Dyn.* 2007, 45, 413.
5. Mirzaeinejad, H.; Mirzaei, M. A novel method for non-linear control of wheel slip in anti-lock braking systems. *Control Eng. Pract.* 2010, 18, 918.
6. Harifi, A.; Aghagolzadeh, A.; Alizadeh, G.; Sadeghi, M. Designing a sliding mode controller for slip control of antilock brake systems. *Transp. Res. Part C: Emerg. Technol.* 2008, 16, 731.
7. Xusanjonov, A. S., & Otaboev, N. I. (2018). Improving Of Steerability Of Automobiles With Rotation Of X-Type Of His Rear Wheels Relatively Of Front Wheels. *Scientific-technicaljournal*, 22(2), 131-133.
8. Khusanjonov, A., Makhhammadjon, Q., & Gholibjon, J. Opportunities To Improve Efficiency And Other Engine Performance At Low Loads.
9. Imamovich, B. B., Nematjonovich, A. R., Khaydarali, F., Zokirjonovich, O. O., & Ibragimovich, O. N. (2021). Performance Indicators of a Passenger Car with a Spark Ignition Engine Functioning With Different Engine Fuels. *Annals of the Romanian Society for Cell Biology*, 6254-6262.
10. Bazarov, B.I., Magdiev, K.I., Sidikov, F. Sh., Odilov, O.Z., & Jamankulov, A.K. (2019). Current trends in the use of alternative motor fuels. *Journal of Advanced Research in Technical Science*, 2 (14), 186-189.

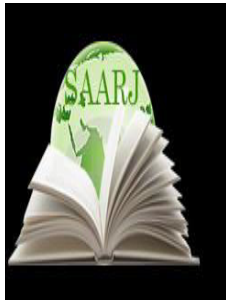

**ACADEMICIA**  
**An International  
Multidisciplinary  
Research Journal**  
(Double Blind Refereed & Peer Reviewed Journal)

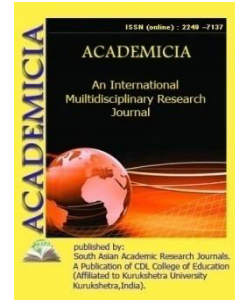

DOI: **10.5958/2249-7137.2021.01952.2**

## HIGH-YIELDING VARIETIES AND LINES FOR BREEDING DURUM WHEAT

**Khasan Xolbazarovich Karshiboev\***

\*Doctor of Philosophy (PhD) in Agricultural Sciences,  
Scientific research Institute of rainfed Agriculture,  
UZBEKISTAN

Email id: [uzniizerno@yahoo.com](mailto:uzniizerno@yahoo.com)

### ABSTRACT

*Based on the correlations between the yield and the weight of 1000 durum wheat grains and between the yield and plant height, a positive relationship was established. According to the results of a comprehensive assessment of varieties of advanced yield trial of durum wheat in terms of yield and resistance to yellow rust, the varieties Billurdon, KSI-2014/22, KP-2016/45, KP-2016/49, KP-2016/55, PSI-2017/30 s were selected high rates for these characteristics.*

**KEYWORDS:** *Variety, Lines, Durum Wheat, Rainfed Areas, Plant Height, Yellow Rust, 1000 Grain Weight, Yield.*

### INTRODUCTION

The increase in grain production, which is the guarantor of the country's food security, largely depends on the yield of cultivated varieties that make up its biological basis [5].

It was found that with an increase in yield during selection, adaptive properties (winter resistance, drought resistance, resistance to brown and yellow rust, powdery mildew) and grain and pasta quality indicators improved or remained at the same level [4].

Conducting research on the assessment of breeding material for yield is one of the conditions for increasing the efficiency of the breeding process when creating varieties that combine high economic productivity with increased resistance to biotic factors. He considers the conditions of the year to be the main factor in the harvest [10].

The most stable elements of the yield structure are: 1000 grain weight, plant survival, length and number of spikelets in an ear [7].

The mass of 1000 grains in arid conditions, where low productive tillering prevails, is one of the most important elements of the crop structure [1].

Productive tillering was reported to be closely related to yield ( $r = 0.77$ ), with little association noted between productive tillering and plant height ( $r = 0.44$ ); between the length and graininess of an ear ( $r = 0.63$ ); between the grain size of an ear and the mass of 1000 grains ( $r = 0.41$ ) [9].

The height of wheat plants, a morphological trait of economic importance, belongs to the category of quantitative ones, the genetic structure of which is rather complex [3], [2].

Plant height positively correlates with plant productivity  $r = 0,63$  [8].

As noted [6], A decrease in the yield of winter wheat during drought was associated with a decrease in plant height (by an average of 27%), the number of ears (by an average of 27%), the number of spikelets in an ear (by an average of 26%) and individual grain mass (on average by 22%).

The purpose of our research was to study and select varieties of durum wheat with high yields and resistance to yellow rust in a competitive variety testing in rainfed conditions.

## **MATERIALS AND METHODS**

The material of our research was the varieties of the competitive variety test of durum wheat of the laboratory of durum wheat breeding and seed production on the rainfed, Scientific research Institute of rainfed Agriculture.

These studies were carried out according to the following methods:

-Methodology for selection and seed production of grain crops, A.O.Omonov et al., Gallaaral 2004.

-Study of the world wheat collection. Methodical instructions. O.D.Gradchaninova, A.A.Filatenko, M.I.Rudenko, Leningrad, 1984.

-Methodology of the State Commission for Variety Testing of Agricultural Crops (1989).

-Mathematical processing of the results obtained was carried out according to B.A.Dospekhov (1985).

## **RESEARCH RESULTS**

In the dry conditions of Uzbekistan, wheat is affected by yellow rust. Therefore, the creation of varieties resistant to this disease is an important task of wheat breeding.

Our studies have shown that for practical breeding, durum wheat varieties are represented, in which resistance to yellow rust dominates, Table 1.

**TABLE 1. YELLOW RUST AND 1000 KERNEL WEIGHT OF VARIETIES AND LINES OF ADVANCED YIELD TRIAL OF DURUM WHEAT IN RAINFED AREAS (GALLAARAL 2018-2020 YY.)**

№	Name of varieties and lines	Yellow rust, (%)			1000 kernel weight, (g)				Difference to standard, (±) (g)
		2018 y.	2019 y.	2020 y.	2018 y.	2019 y.	2020 y.	average	
1	Leukurum-3(st)	10	20	20	42,0	40,0	39,2	<b>40,4</b>	±
2	Javohir	10	20	15	42,0	41,0	41,2	<b>41,0</b>	0,6
3	Marvarid	15	40	40	40,0	39,0	40,8	<b>39,9</b>	-0,5
4	Yoqut-2014	10	10	10	39,4	40,0	40,0	<b>39,8</b>	-0,6
5	Billurdon	5	10	5	40,0	41,0	40,8	<b>40,6</b>	0,2
6	454612	5	20	5	40,8	40,0	40,0	<b>40,2</b>	-0,2
7	KSI-2014/22	0	5	5	42,4	42,0	42,8	<b>42,4</b>	2,0
8	PSI-2013/20	0	10	5	42,0	40,8	40,8	<b>41,2</b>	0,8
9	KP-2013/52	5	5	10	36,4	36,0	35,6	<b>36,0</b>	-4,4
10	KSI-2014/20	10	10	20	40,4	40,0	40,8	<b>40,4</b>	±
11	PSI-2016/8	5	5	10	40,0	40,0	40,0	<b>40,0</b>	-0,4
12	KP-2016/45	5	5	5	42,6	41,0	41,6	<b>41,7</b>	1,3
13	KP-2016/49	5	5	5	42,0	43,0	43,2	<b>42,7</b>	2,3
14	KP-2016/55	5	20	5	43,2	40,8	45,6	<b>43,2</b>	2,8
15	PSI-2017/30	5	5	5	38,8	40,0	38,4	<b>39,0</b>	-1,4
16	KP-2017/17	0	20	20	40,2	40,0	40,0	<b>40,1</b>	-0,3
17	KP-2017/19	5	30	30	40,4	39,0	43,6	<b>41,0</b>	0,6
18	PSI-2018/26	-	10	10	-	44,0	44,8	<b>44,4</b>	4,0
19	PSI-2018/30	-	20	10	-	40,0	42,0	<b>41,0</b>	0,6
20	KP-2018/69	-	10	5	-	40,0	40,8	<b>40,4</b>	±
21	PSI-2019/20	-	-	5	-	-	43,2	<b>43,2</b>	2,8
22	PSI-2019/30	-	-	10	-	-	42,0	<b>42,0</b>	1,6
23	KP-2019/7	-	-	20	-	-	42,0	<b>42,0</b>	1,6
24	KP-2019/51	-	-	20	-	-	42,0	<b>42,0</b>	1,6
25	KP-2019/52	-	-	20	-	-	42,0	<b>42,0</b>	1,6
26	KP-2019/57	-	-	5	-	-	42,4	<b>42,4</b>	2,0
27	KP-2019/75	-	-	10	-	-	43,2	<b>43,2</b>	2,8
	<b>r =</b>							<b>0,44</b>	

The data in the table show that high yellow rust infestation occurs in years with a large amount of precipitation, so in 2019 - 2020. (483.4 mm - 391.0 mm) the percentage of yellow rust damage in durum wheat ranged from 5 to 40 for varieties, and in dry 2018 (241.0 mm) - from 0 to 15.

The 1000 kernel weight was for durum wheat varieties in 2018 from 38.8 g (PSI-2017/30) to 43.2 g (KP-2016/55), for the standard 42.0 g (Leukurum-3), in 2019 - from 36.0 (KP-2013/52) to 43.0 (KP-2016/49), for the standard 40.0 g (Leukurum-3), in 2020. - from 35.6 g. (KP-2013/52) to 45.6 g. (KP-2016/55), for the standard 40.4 g (Leukurum-3).

In the durum wheat varieties studied by us, the plant height on average for varieties ranged from 100.3 cm (PSI-2016/8) to 127.2 cm (KP-2016/45), depending on the conditions of the year, (Table 2).

**TABLE 2 PLANT HEIGHT, PRODUCTIVITY OF VARIETIES AND LINES OF  
ADVANCED YIELD TRIAL OF DURUM WHEAT IN RAIN FED AREAS  
(GALLAARAL 2018-2020 YY.)**

№	Name of varieties and lines	Plant height, (cm)				Yield, (c/ha)				to standard, (±)
		2018 r.	2019 r.	2020 r.	average	2018 r.	2019 r.	2020 r.	average	
1	Leukurum-3(st)	83,4	121,0	112,8	105,7	6,0	17,3	20,4	<b>14,6</b>	±
2	Javohir	86,6	126,8	115,2	109,5	6,5	17,6	20,9	<b>15,0</b>	0,4
3	Marvarid	86,4	129,2	119,2	111,6	6,0	16,8	18,5	<b>13,8</b>	-0,8
4	Yoqut-2014	79,0	127,6	116,2	107,6	7,3	18,7	22,1	<b>16,0</b>	1,4
5	Billurdon	76,4	127,6	119,0	107,7	7,5	18,8	22,5	<b>16,3</b>	1,7
6	454612	84,2	129,8	118,6	110,8	6,6	18,1	20,6	<b>15,1</b>	0,5
7	KSI-2014/22	89,6	128,2	122,0	113,2	8,4	18,2	23,4	<b>16,7</b>	2,1
8	PSI-2013/20	89,2	125,8	116,2	110,4	6,5	19,2	19,8	<b>15,2</b>	0,6
9	KP-2013/52	92,2	139,2	121,0	117,5	7,0	18,1	19,9	<b>15,0</b>	0,4
10	KSI-2014/20	78,4	126,2	120,2	108,3	7,3	17,8	19,6	<b>14,9</b>	0,3
11	PSI-2016/8	73,4	115,2	112,4	100,3	6,5	17,7	22,2	<b>15,5</b>	0,9
12	KP-2016/45	95,2	158,4	128,0	127,2	7,6	19,5	23,6	<b>16,9</b>	2,3
13	KP-2016/49	90,0	127,4	110,2	109,2	7,8	17,6	23,5	<b>16,3</b>	1,7
14	KP-2016/55	75,6	127,2	116,6	106,5	6,6	18,7	23,6	<b>16,3</b>	1,7
15	PSI-2017/30	77,6	122,6	112,8	104,3	6,5	18,3	24,1	<b>16,3</b>	1,7
16	KP-2017/17	86,0	134,2	119,4	113,2	6,9	19,0	19,8	<b>15,2</b>	0,6
17	KP-2017/19	83,0	142,2	130,0	118,4	7,0	16,5	23,1	<b>15,5</b>	0,9
18	PSI-2018/26	-	129,2	119,6	124,4	-	17,5	23,4	<b>20,5</b>	5,9
19	PSI-2018/30	-	134,2	112,8	123,5	-	19,6	22,0	<b>20,8</b>	6,2
20	KP-2018/69	-	128,8	111,4	120,1	-	18,1	22,2	<b>20,2</b>	5,6
21	PSI-2019/20	-	-	117,0	117,0	-	-	23,4	<b>23,4</b>	8,8
22	PSI-2019/30	-	-	119,2	119,2	-	-	23,7	<b>23,7</b>	9,1
23	KP-2019/7	-	-	119,2	119,2	-	-	22,9	<b>22,9</b>	8,3
24	KP-2019/51	-	-	126,2	126,2	-	-	23,4	<b>23,4</b>	8,8
25	KP-2019/52	-	-	118,6	118,6	-	-	19,1	<b>19,1</b>	4,5
26	KP-2019/57	-	-	120,2	120,2	-	-	24,8	<b>24,8</b>	10,2
27	KP-2019/75	-	-	120,4	120,4	-	-	23,5	<b>23,5</b>	8,9
	<b>HCP<sub>05</sub> = <math>\mu</math>/ra</b>				<b>r=0,16</b>	<b>0,53</b>	<b>0,84</b>	<b>0,89</b>		

According to the tabular data, it can be seen that the height of durum wheat plants also depended on the amount of precipitation. In dry 2018, the height of durum wheat plants ranged from 73.4 cm (PSI-2016/8) to 95.2 cm (KP-2016/45), for the standard 83.4 cm (Leukurum-3); in favorable 2019 - from 115.2 cm (PSI-2016/8) to 158.4 cm (KP-2016/45), for the standard 121.0 cm (Leukurum-3) and in 2020 - from 110 , 2 cm (KP-2016/49) to 130.0 cm (NP-2017/19), at the standard 112.8 cm (Leukurum-3).

The high yield of durum wheat varieties in 2019 was from 16.5 c / ha (KP-2017/19) to 19.5 c / ha (KP-2016/45), the standard of 17.3 c / ha (Leukurum- 3), in 2020 - from 18.5 c / ha (Marvarid) to 24.1 c / ha (PSI-2017/30), for the standard 20.4 c / ha (Leukurum-3). A low yield of durum wheat was observed in the dry 2018 and it ranged from 6.0 c / ha (Marvarid) to 8.4 c / ha (KSI-2014/22), for the standard 6.0 c / ha (Leukurum-3 ).

**CONCLUSIONS.** Based on the studies, the influence of meteorological conditions on the susceptibility to yellow rust, plant height, 1000 grain weight and durum wheat yield was noted.

When studying the correlations between the yield and the weight of 1000 durum wheat grains, a positive relationship was established ( $r = 0.44$ ) and between the yield and plant height ( $r = 0.16$ ).

Selected varieties of advanced yield trial of durum wheat with high yields and resistance to yellow rust Billurdon (16.3 c / ha, degree of susceptibility 5-10), KSI-2014/22 (16.7 c / ha, degree of susceptibility 0-5) , KP-2016/45 (16.9 c / ha, degree of infestation 5), KP-2016/49 (16.3 c / ha, degree of infestation 5), KP-2016/55 (16.3 c / ha, the degree of susceptibility is 5-20), PSI-2017/30 (16.3 c / ha, degree of susceptibility is 5).

## REFERENCES

1. Bekenov S.B, Abdullaev K.K, Bekenova L.V. Selection value of spring wheat samples. The KASIB program in the conditions of the Pavlodar Pri Irtysh region. // Bulletin No. 2 of the regional network for the introduction of wheat varieties and seed production. Almaty, 1982, p. 25 - 30.
2. Gorbatenko N.Yu. Manifestation of the "stem length" trait and changes in its anatomy in winter wheat hybrids under irrigation conditions. Cytology and Genetics, Vol. 14, No. 6 1980, Art. 48-52.
3. Prilyuk L.V. Short-stemmed wheat. // Agricultural biology. T.12, No. 4, 1977, p. 493-499.
4. Samofalova N.E., Ilychkina N.P., Dubinina O.A., Makarova T.S., Kostylenko O.A., Kameneva A.S., Derova T.T., Kravchenko N.S. The history of the development of breeding work on the creation of winter durum wheat: results, problem, prospects. // Grain economy of Russia. 2020; (6): 10-18.
5. Sandukhadze B.I. Winter wheat varieties with high yield and grain quality potential. // Bulletin of Agrarian Science. 2009.
6. Saulescu N.K., Mustatna P., Ittu G. Methods and results of selection for drought resistance of winter wheat at the Agricultural Institute of Romania. // Bulletin of the regional network for the introduction of wheat varieties and seed production. No. 1, 1-2 (7-8), Almaty, 2004, p. 101-108.



7. Sereda G.A., Sereda S.G. Methods of creation and results of selection of early-maturing varieties of spring bread wheat in Central Kazakhstan. // Bulletin of the regional network for the introduction of wheat varieties and seed production. Almaty No. 1 (4), 2003, p. 106-111.
8. Fadeeva O.I., Osipov Yu.F., Kovalenko V.V., Lapatina L.M., Kolesnikov F.A., Kazareva A.M. Physiological assessment of the productivity of winter wheat varieties using factor analysis. // Agricultural biology, no. 6, 1984, p. 47-51.
9. Khojakulov T.Kh. Breeding of bread wheat under irrigated conditions in Uzbekistan. // 1st Central Asian Wheat Conference. June 10-13, 2003. p. 97.
10. Belan J. Ecological flexibility and stability of spring bread wheat – varieties. 5 th international wheat conference, June 10-14, Ankara, Turkey, 1996, p.12.

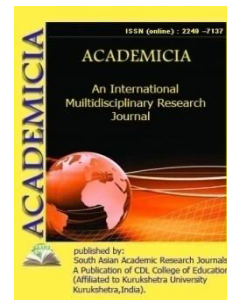
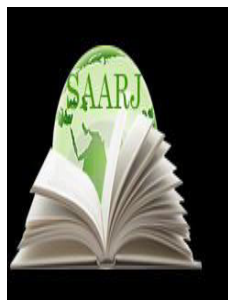

DOI: **10.5958/2249-7137.2021.01953.4**

**STUDYING THE LIFE AND WORK OF SHUKRULLO IN UZBEK-TURKISH LITERATURE (BASED ON RESEARCH BY NUMONJON RAKHIMJANOV AND SHUAYIB KARAKASH)**

**Marhabo Xudayberganovna Kuchkarova\***

\* Senior Researcher,  
Doctor of philological sciences, Literature and folklore,  
Academy of Sciences of the Republic of Uzbekistan Uzbek Language,  
UZBEKISTAN

**ABSTRACT**

*The article examines the life and work of the national poet of Uzbekistan Yusuf oglu in the study of the Uzbek-Turkish literary scholars Numonjon Rakhimjanov and Shuayib Karakash. The most important thing is that under the constant light of Gafur Gulam, the great philosopher and poet of our time, Shukrullo became a great lyric poet. The scientist pays special attention to the poems of Shukrullo, in particular, analyzes the poems of the poet "Russia", "Two Rocks", "Dawn 26", "Fire and Flower" in the system of Uzbek poetry of the 20th century.*

**KEYWORDS:** *Shukrullo, Epos, Memoir Prose, Rakhimjanov, Shuayib Karakash, Turkish And Uzbek Literature, Creativity.*

**INTRODUCTION**

People's poet of Uzbekistan, honored cultural worker of Uzbekistan Shukrullo is one of our artists who lived a long life, but during this long life he went through many hardships. Shukrullo was sentenced in 1951 to 25 years in prison on charges of nationalism and anti-Soviet propaganda and released in 1955 after Stalin's death. About this tragic fate, about the gloomy days of the repressed in exile, the author of his autobiographical memoirs «Buried without a shroud»

Shukrullo created dozens of collections of poems in a collection of Uzbek literature: "First Book" (1949), "Songs of the Heart" (1949), "Inspiration of Life" (1959), "While I Live". (1960), "Man and Good" (1961), "Man for Man" (1964), "Particles" (1973), "Your happiness"(1988). The writer also made a great contribution to the development of modern Uzbek epic poetry. In particular, the author's works include "Old Men" (1948), "Russia" (1956), "Two Rocks" (1964),

"26 Morning Sheep" (1966), "Flower and Fire" (1972), "Light souls "(1975) and " The Age of Debate "(1985). Shukrullo also has many poems and fairy tales dedicated to children. Essays on "Dangerous Road" (1962), "Smile at the Thieves" (1964), "After the Wedding Show" (1980), "The Thief Defeated the Thief" (1982), "Jewelry Box" (1983), which discuss the creative experience of the writers -masters, also significant are the autobiographical story "Buried without a shroud" (1989), a collection of journalistic articles "The Vengeful World" (1994), a novel-chronicle about Ubaydulla Khojaev "Living Souls" (1999) about the horrors of repression. in the history of Uzbek art and journalism. Shukrullo as a translator Carlo Gotsi's poem "Happy Beggars», He translated the poems of Petofi, T. Shevchenko, K. Kuliev and other poets into Uzbek. In a word, Shukrullo left a deep mark on the history of Uzbek literature with his poems, epics, documentary memoirs and translations.

Shukrullo's research in various literary genres and genres has been studied by our literary scholars, large and small. In particular, in the studies of our scientists, such as M. Kushzhanov, N. Karimov, S. Mirzaev, B. Nazarov, S. Mirvaliev, N. Rahimdzhanov, I. Gafurov, the multifaceted works of the poet and prose writer were analyzed. explored.

Of course, in one article it is impossible to dwell on the scientific work of dozens of scientists who have studied the life and work of Shukrullo. Therefore, among them is the book "The Poet and the Period. Reflections on the work of Shukrullo "and the article" About Shukrullo Yusuf oglu and his works ", included in the book" Studies of Uzbek Literature "by the Turkish scientist, Doctor of Philology, Professor Shuayib Karakash (Turkey: Ankara, 2012).

Although N. Rakhimdzhanov's monograph "The Poet and the Period" was created in the literature of the Soviet period, it is important to give an objective assessment of Shukrullo's poetry by analyzing the main poetic images in the poet's poetry and their important artistic features. In this monograph N. Ragimdzhanov examines the lyrics of Shukrullo in a total of seven chapters, including the "Introduction". Among them are "Blue River", "In the desire to taste the sun", "He separated colors from words, tone from color", "Good in the interpretation of a poet", "Heart and Philosophy", "Period and Hero". Individual stylistic aspects ". The scholar emphasizes that Shukrullo's devotion to poetry came from his mother and that Shukrullo became a great lyric poet under the tutelage of Gafur Gulam, one of the great masters of Uzbek poetry of the 20th century. For example: ". Firstly, a respected mother will be a person who, with a verse, will raise Shukrullo's forehead and put poetic tones in his ears.

The most important thing is that under the constant light of Gafur Gulam, the great philosopher and poet of our time, Shukrullo became a great lyric poet. " In addition, the scientist constantly studies the importance of the advice and instructions of Shukrullo from the great poets and writers of his time, such as Oybek, Hamid Olimjon, MaksudShaikhzoda, Abdulla Kakhhor, Uygun, in order to find his place and voice in this area. Uzbek poetry.

N. Ragimdzhanov also conducts an objective study of Shukrullo's poetry, which often mentions landscape poetry, images and themes such as the sun, homeland, time, man and good, love, love, and sometimes schematic patterns. The scientist also noted that in the work of Shukrullo, the theme of Lenin, the genius of the proletariat, was worked out very widely. For example, a scientist writes: "In the lyrics of Shukrullo, the theme of Lenin is distinguished by the fact that it further supplements and enriches the theme of man and good, which constitutes the main content of his work" [1. 48.]. N. Rakhimdzhanov also explores the features of such calendar poems in

Shukrullo's poetry related to the social period, as well as the fact that the poet's lyric poems and lyric miniatures are updated from year to year. Consequently, he writes: "... the bulk of the poet's lyrics in recent years (in particular, most of the poems that define the content of the collection ("I want to live") consists of poems with a plot; and lyrical miniatures constitute a minority in the poetry of the poet of this period. Apparently, therefore, Shukrullo in recent years has little regard for miniatures, lyric-miniature forms; we can see that his thoughts and feelings about time and people, time and reality take on more lyroepic forms" [1. 68].

The scientist also emphasizes that the lyrics of Shukrullo of the 1970s "have a strong tendency to philosophically understand and generalize events, human life and destiny." When N. Rakhimdzhonov talks about philosophy in Shukrullo's poetry, he means the artistic comprehension of eternal questions. Scientist: "The philosophical lyricism of Shukrullo is a spiritual and philosophical problematic character in the sense that it covers the eternal themes of man and nature, good and evil, beauty and ugliness, life and death, love and devotion" [1. 79] - concludes.

The scientist pays special attention to the poems of Shukrullo, in particular, analyzes the poems of the poet "Russia", "Two Rocks", "Dawn 26", "Fire and Flower" in the system of Uzbek poetry of the 20th century. In particular, let us dwell on the scientist's important scientific theses about the poem "Old Men": "The old people appeared as a sign of the creative development of Shukrullo"; "The poet knew how to individualize the character of old people with very specific characters. This, of course, is the result of the poet's careful study of the character and character of older people in life"; In the poem "Chollar" (Old men), the patriotic feelings of the old Uzbek cotton growers reflect the life of Uzbek villages after the war and, on this basis, a part of the life of the Uzbek people, a wave of emotions in the hearts of our people. As you can see, the success of the poem "Chollar" (Old men) in the work of Shukrullo N. Rahimdzhanov was able to explain with deep thoughts. In general, the scientist emphasizes the great importance of Shukrullo's poems in the development of Uzbek poetry as follows: it contributes to the emergence of a specific mixture of psychological analysis" [1.162].

It is important to note that in this monograph on the life and work of Shukrullo N. Rakhimdzhonov highlights important features that characterize the style of the writer. He was able to deeply and thoroughly study his personality as a unique creator.

Now let us turn to the study of the great Turkish Uzbek scientist Professor Shuayib Karakash "About Shukrullo Yusuf oglu and his works " In the study of the life and work of the Turkish scientist Shukrullo, the author's autobiography "About Me", the author's autobiographical, documentary-memoir works "The Vengeful World", "Jewelry Box", as well as his "Life Time" by his contemporaries. Memories included in the collection "Various aspects of Shukrullo's work" are based on information and facts about the biography and work of the poet. The scientist also reports the birth of Shukrullo in Tashkent and his parents. He stressed that his father was a doctor and that he became a religious doctor who treated infectious diseases such as measles, chickenpox and plague. The poet's mother, Zainab, was an educated woman who taught children from the area where she lived to read and write.

Shuayib Karakash learned that Shukrullo entered the realm of literature with poetry and then wrote in other genres: In short, if it is necessary to contact, the work called Çallara, which is

about the efforts of an Uzbek cotton farmer to open new agricultural areas, can be considered as a work that contributes to modern Uzbek epic culture” [2. 426.].

ShuayibKarakosh, like N. Rakhimdzhonov, emphasizes the special significance of the “Chollar”(Old men) epic in Shukrullo's work, but without going into a detailed analysis. In the article, the Turkish scientist devotes more space to the analysis of Shukrullo's documentary memoirs. In particular, he focuses on the author's works "Buried without a Head" and "Living Souls". This is because scholar Shukrullo chooses these two works as the key to understanding the years of Stalinist repression, the personality of the writer and his creative laboratory. This research of the scientist is not in the form of a large monographic book. The article is larger. Shuayib Karakash concludes the article with the following conclusions: The novel called *Kefensiz Kömilgenler*, which was met with great interest when it was published in Uzbekistan in 1990, was also published in Turkey by D. Ahsen Batur in 2005” [2. 432.]. In a word, the article by the Turkish scholar Shuayib Karakash about the life and work of Shukrullo is based on the spirit of the new era and the criteria of modern literature. Shukrullo's documentary memoirs “Buried without a shroud” became a great event not only in Uzbek literature, but also in the literature of the Turkic peoples. This is because the author reveals the repression of Stalinism in this work based on real historical documents that he personally experienced.

Although N. Rakhimdzhonov's monograph "The Poet and the Period", created in the 80s, is devoted to the study of Shukrullo's place in the poetry of the Soviet period, the factors of his formation as a poet, the first creative stage, poetic images in Shukrullo's poetry, themes and periods, artistic comprehension of modern problems. It became clear that he was right. The scientist prefers to study the creative person on the basis of the biographical method and adhere to this approach in his work. [3] Shuayib Karakash, who created his study in 2009, does not focus on the social aspects of Shukrullo's work during the Soviet era, but focuses on the scientific value of documentary memoirs that flare up in the writer's work.

Shukrullo holds a firm place in the history of Uzbek literature with his poems, documentary memoirs, artistic journalism and translations. Interest in the life and work of Shukrullo is growing not only to Uzbek literature, but also to Turkic-speaking peoples such as Turks, Azerbaijanis, Kazakhs and Kyrgyz, as well as to Russian-European literature.

#### REFERENCES:

1. Ragimdzhonov N. Poet and period. Thoughts on the work of Shukrullo. Tashkent: Publishing house of literature and art Gafur Gulam, 1983.
2. Karakaş Ş. Özbek edebiyatı Yazıları. – Ankara: Kurgan edebiyat, 2012.
3. Tulaganova S. Biographical approach as a scientific-theoretical problem (on example of Russian literature) *Academicia: An International Multidisciplinary Research Journal* Year: 2021, Volume: 11, Issue: 3.
4. Sattorova G. Typological similarities in Uzbek and Turkish stories. *ELMø øù (beynq̇lxalq elmijurnal)* 2020 4/53.
5. Khudoyorovich, K. K., Rasuljanovna, I. N., Khalmuratovna, R. Z., & Eshkobilovna, K. D. (2020). The Issues of Word Choice in Fiction Translation. *International Journal of Psychosocial Rehabilitation*, 24(04).

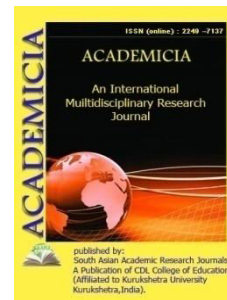
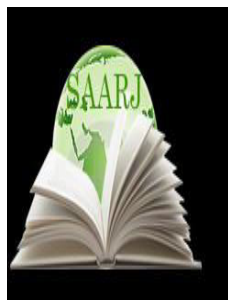

DOI: **10.5958/2249-7137.2021.01954.6**

## PROSPECTS FOR THE DEVELOPMENT OF DISTANCE EDUCATION (IN THE EXAMPLE OF KARSHI STATE UNIVERSITY)

**Norkhol Guzarovna Eshkoraeva\***; **Bahodir Haknazarovich Shovaliev\*\***;  
**Jahongir Qobil ugli Odilov\*\*\***

\*Associate Professor,  
Candidate of Technical Sciences, Karshi State University,  
UZBEKISTAN

\*\*Senior Teacher,  
Karshi State University, UZBEKISTAN

\*\*\* Teacher,  
Karshi State University, UZBEKISTAN

### ABSTRACT

*The article is based on the work done by Karshi State University in the framework of the project "New technologies in forming education process in high education institutions of Uzbekistan" with the investment of the World Bank for the development of distance education, the work done by the university in the introduction of distance learning.*

**KEYWORDS:** *Distance Learning, Technology, Software Products, Software, Moodle Platform, Server, Workstation, Project*

### INTRODUCTION

We know that the recent changes in the world have necessitated reforms in the field of education. Due to quarantine, the form of education in higher education institutions of Uzbekistan, as well as in many educational institutions around the world, has been determined remotely. In February 2019, the specialists of Karshi State University launched the project "New technologies in the organization of the educational process in higher education institutions of Uzbekistan" on the basis of the AIF Fund of the World Bank. As part of the project, the focus was on increasing the effectiveness of students' independent learning, and a mechanism for the full implementation of independent learning was formed. Initially, 1st year courses in applied mathematics and computer science, chemistry, philology, and language teaching were selected as experiments. All subjects in these areas were registered on the Moodle platform and students were provided with



electronic resources on the platform. In the 2019-2020 academic year, these areas of study began to fully master all the subjects intended from the curriculum through the distance learning platform, in addition to the platform. Bukhara State University professors for applied mathematics, computer science and chemistry, philology and language teaching; professors from Belgorod National Research University (Russian Federation) participated in the study of English as an expert and assessed students' knowledge.

### THE MAIN FINDINGS AND RESULTS

The main goal of the project is to apply transparency-based technologies for the assessment of students' knowledge, to create the preconditions for the introduction of distance learning, to develop an improved mechanism for evaluating the performance of teachers. The model of the project is shown in Figure 1 below.

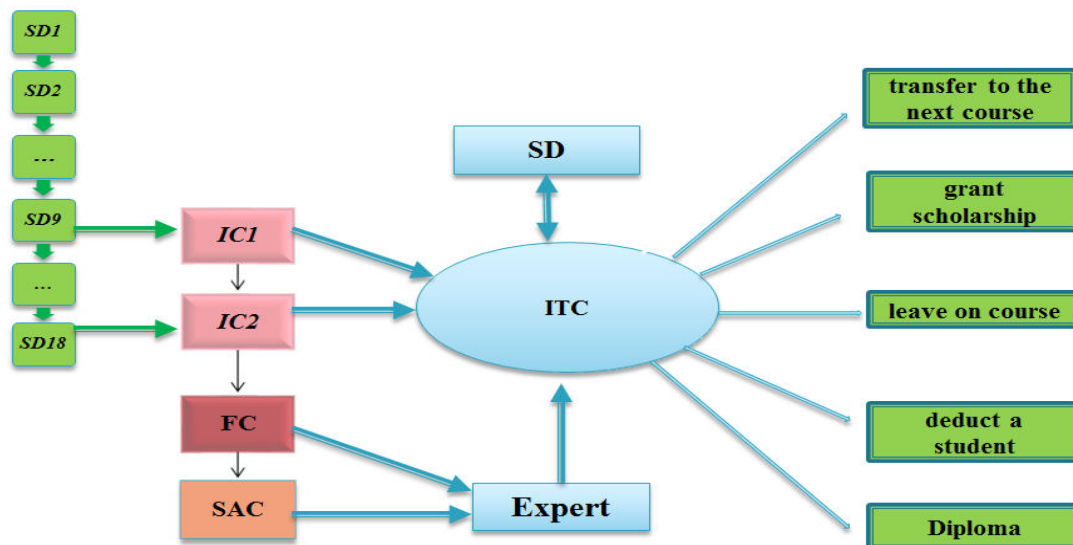

Figure 1. Model of the project

Here SD1, SD2,... SD18 - independent Study (independent assignments), IC1, IC2, FC - types of control, respectively, FSC - final state certification, EMM - educational and methodical management, ITC - information technology center.

Within the framework of the project, the material and technical base of the university has been sufficiently strengthened. Server device, Canon 5325i, Canon 2520 devices, AVER 520 camera, CANON 6D camera, more than 60 modern computers were purchased. We present the work done on the basis of:

The server device is installed in the central server room of the university,

allows the installation of a distance learning platform and extensive use of the system (Figure 2);

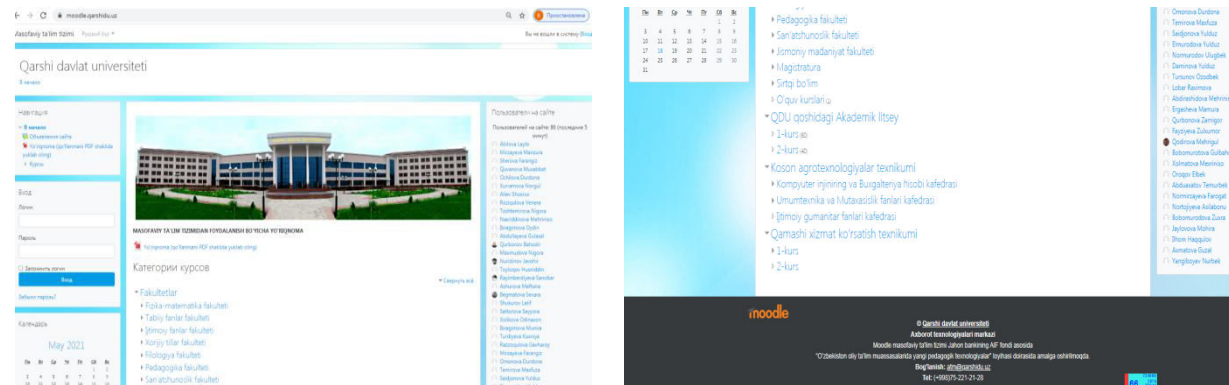

Figure 2. Overview of the Moodle platform

Evaluation of Canon 5325i, Canon 2520 devices as well as test runstests were conducted among the students using automation software and verification was set up using the above hardware. With the help of AVER 520 camera, high-quality video conferencing, on-line webinars, on-line lectures were organized, as well as a distance learning center was established at the Faculty of Physics and Mathematics of the university. Using the CANON 6D camera, professors and teachers record videos of lectures and laboratory classes. In general, the creation of e-textbooks, e-textbooks remains the main task; Computers - More than 60 computers were purchased under the project. All computers are state-of-the-art computers, 30 of which were transferred to the Information Resource Center, 15 to the Faculty of Pedagogy, and 15 to the Department of Applied Mathematics, which is involved in the project. Its main purpose is to strengthen the material and technical base of the university, to support distance learning and to create adequate conditions for students.

As part of the project, the university's distance learning platform was created. The platform operates at <https://moodle.qarshidu.uz>. Initially, the platform included only applied mathematics and computer science, chemistry, philology and language teaching: 1st year courses in English language teaching and their subjects taught. This process took 6-7 months. It is known that in our country, as in the rest of the world, due to the spread of coronavirus, the quarantine regime has been strengthened and the transition to a distance system in self-education. The work we have already started in the framework of our project has given an experimental role to the system, professors and students, which was in operation until the quarantine period. Admittedly, this was a great opportunity to transfer to distance learning at the university. From April 1, 2020, all subjects at the university have been placed on the platform and education has been transferred to a distance form. As of April 15, 2020, 1830 subjects were placed on the distance learning platform at the university.

TABLE 1

Faculties	Number of subjects	Daytime shift	Distance Learning
Physics and Mathematics	<b>209</b>	<b>129</b>	<b>80</b>
Natural Sciences	<b>202</b>	<b>158</b>	<b>44</b>
Social Studies	<b>292</b>	<b>226</b>	<b>66</b>

Foreign Languages	357	357	0
Philology	155	120	35
Science of Art	208	162	46
Pedagogy	243	138	105
Physical Education	71	45	26
Department of Master's Degree	93	93	0
Distance Learning	402	0	402
<b>TOTAL</b>	<b>1830</b>	<b>1428</b>	<b>402</b>

Electronic resources for all subjects have been posted and updated. It is enriched with elements such as lecture, assignment, test, seminar, glossary, forum, chat, database, book, hyperlink, folder, file, page. Interactions between professors and students are established on the platform.

To date, as a result of a sharp increase in the number of students, a distance learning platform has been developed for part-time students at <https://sirtqi.qarshidu.uz> and subjects are introduced and used by professors and teachers. The project also provides a platform for evaluating the performance of teachers on a 110-point scale. This, of course, plays an important role in improving the quality and effectiveness of education.

## CONCLUSION

We can note that Karshi State University has done a lot to create the preconditions for distance learning, the use of technologies based on transparency in the assessment of students' knowledge, the creation of an automated system for evaluating the performance of teachers. This means that the introduction of digital technologies in higher education will facilitate the work done in the system, as well as increase the efficiency of education.

## REFERENCES:

1. Yu.H.Eshqobilov, N.G.Eshqorayeva, B.H.Shovaliyev. Moodle platform and its use. Karshi State University, educational-methodical edition, Karshi -2020.
2. Gilmutdinov A.Kh. Electronic education on the MOODLE platform. Kazan, KSU. - 2008. – 169 p.
3. Engel V. Moodle for beginners. Overview of Moodle Q&A / V. Engel.– MoodleCenter, 2012 - 18 p.
4. Ismatullayeva, N. R. (2021). On the Introduction of E-Learning Portfolio in the Educational Process. *Current Research Journal of Pedagogics* (2767-3278), 2(09), 35-37.



**ACADEMICIA**  
**An International  
 Multidisciplinary  
 Research Journal**  
 (Double Blind Refereed & Peer Reviewed Journal)

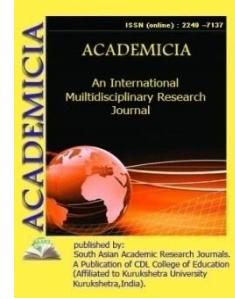

**DOI: 10.5958/2249-7137.2021.01955.8**

## THE ROLE OF FOREIGN MIGRATION IN THE DEVELOPMENT OF NATIONAL DIASPORAS

**Shahnoza Tillybaeva\***

\*Doctoral student,  
 Department of Sociology and Psychology of Management,  
 Academy of Public Administration under the President,  
 Republic of UZBEKISTAN

### ABSTRACT

*In this article, the author studies the views of various scholars on the phenomenon of “external migration”, defines the concept of “migration”, analyzes the factors affecting external migration to the diaspora. Models for the management of migration processes and the experience of foreign countries are studied. Problems in the management of migration processes and their impact on the national diaspora are analyzed on the example of Uzbekistan and recommendations are given.*

**KEYWORDS:** *Migration, Diaspora, Migrant, External Migration, Migration Balance, Emigration, “Jus Sanguinis”, “Jus Solis”.*

### INTRODUCTION

In studying the nature of national diasporas, it is necessary to emphasize the various social phenomena that explain diasporas. National diasporas do not be strongly influenced by external migration from a country that is a historical homeland to this country to maintain their sociological status, culture, national values (language, traditions, etc.). External migration affects the lifestyle of national diasporas in the following areas:

1. To be the primary source for the formation of national diasporas on the territory of foreign countries.
2. Preserving the cultural identity of the national diasporas and preventing their assimilation by the local population.
3. Ensuring close ties with the population of the country, which is the historical homeland of national diasporas, and transforming changes in mental values.

4. Ensuring the need of human diasporas in human resources and solving demographic problems.
5. Economic and social development of national diasporas on the basis of migration, raising the image of the state as a historical homeland.

In recent years, migration has been at the center of active political debate in the international arena. One of the main reasons why people are now involved in migration processes is the difference in income between the countries of origin and the countries of destination.

External migration of the population, from the economic point of view, is an objective process and plays a spontaneous role in the formation of national diasporas.

Today, population migration is the object of research in many disciplines, such as sociology, law, political science, economics, philosophy. As Z.H.Rayimjanov said, “the history of mankind is closely linked with the history of migration”. In the international arena, as a result of the establishment and development of relations between states, we can see that the factors that prevent people from crossing administrative and territorial borders and freely communicating in the pursuit of their goals have disappeared.

Most of the existing national diasporas in the world have emerged as a result of the establishment of international cooperation and relations between these countries.

The desire of people to live in countries with good living and working conditions and high wages in order to realize their dreams is contributing to the development of migration processes in the international arena. In the context of globalization, the increasing participation of the population in migration processes indicates the need to develop perfect social mechanisms in this area.

In the process of globalization, population migration has become a social phenomenon that is not mandatory, but only based on economic interests. The formation of modern diasporas is also largely based on economic interests.

Population migration is a concept in a broad sense, it is understood that citizens cross administrative-territorial boundaries based on their goals and objectives. At present, the issue of regulation of citizens involved in migration processes in the international arena, control over its management has become one of the global problems of countries around the world. A migrant participating in migration processes has limited opportunities in the community, regardless of any strong potential or level of professionalism. To date, various theories on employment, unemployment problems and their solutions have been developed.

In particular, A.Smith’s “unshakable hand of the market,” which is able to balance the demand for labor and its supply<sup>2</sup>, A.Marshall’s theories of the crisis-free development of a market economy<sup>3</sup> can be recalled by regulating the supply and demand of labor for employment.

One of our national researchers, O.B.Otamirzaev, A.A.Qayumov, A.M.Kopirov, H.M.Nazarova<sup>4</sup> and several other Uzbek scholars have also studied the field of migration on a scientific basis.

---

<sup>2</sup>Smith A. Exploration of the nature and origins of the richness of peoples. –Moscow: 1976.-332 p.

<sup>3</sup>Marshall A. Principles of economic science. V 3-x tomax. – Moscow: Izdatelskaya group “Progress”, 1993.

<sup>4</sup> Каюмов А.А. Ўзбекистан меҳнат ресурсларининг шаклланиши ва ривожланишининг социал географикасослари. Автореферат г.ф.д. - Т., 1994, 40б.; Ата-Мирзаев О. Потенциал сельско-городской миграции молодёжи в Узбекистане. М.:1999. 28с.; Назарова Х-М. Оила тараккиётида аҳоли миграциясининг роли. Рисола. Т.,

Given the active participation of people in migration today, let's define the concept of population migration. The term "migration" is derived from the Latin word "migratio", which means "moving". Despite the widespread use of this term, there is no single interpretation of it. The International Organization for Migration defines migration as "the movement of people from their place of residence across an international border or within a state border". The concept of migration has been variously defined by scientists and experts. In his works, Russian scholar O.D.Vorobyov focuses on the participation of the population in migration processes, describing any territorial migration in which the population crosses the internal and external borders of the country to change their place of residence or education and employment.

According to A.Achiezer, sustainable mass migration is an activity aimed at realizing the values of certain groups of the population through temporary or permanent change of residence, depending on its importance, and is one of the elements of changing people's lifestyles. Forced relocation by the authorities is also considered migration. The role and importance of migration in society can change to such an extent that even that society itself can be considered a product of migration (for example, the United States was formed and developed as a result of population migration in some countries around the world). Accordingly, migration is an important problem of a society, the conditions of its change, the result, the result of overt or covert processes.<sup>5</sup>

Summarizing the above points, Population migration serves to demonstrate human rights and freedoms, the formation and development of national diasporas, national values, democratic traditions.

Ernst Georg Ravenstein, a German scientist of German descent, is the founder of the "theory of migration". At the end of the 19th century, he created "The Law of Migration", in which he substantiated the following 11 principles of migration based on the analysis of migration processes in countries:

1. Most migration takes place over short distances.
2. Migration occurs gradually.
3. Long-distance migration will be mainly directed by large industrial and commercial centers.
4. Each migration flow will have its opposite flow.
5. Urban residents are less mobile than those in rural areas.
6. Women are more active in internal migration, and men are more active in external migration.
7. The majority of migrants are older people, families rarely migrate outside their country.
8. The larger the big cities, the more the natural growth of their population will increase as a result of migration.
9. The scale of migration will increase as a result of the development of industry and trade, especially transport.
10. Regions differ mainly depending on their economic characteristics.

---

1999й.; *Расулова Д.В.* Бозор муносабатлари тизимида ишчи кучи миграциясининг назарий- услубий асосларини такомиллаштириш. Автореф. и.ф.д. - Т., 2010 й., 40

<sup>5</sup>*Ахиезер А.* Миграция и урбанизация в СНГ и Балтии в 90 годы. Под ред. Ж. А. Зайончковской. М., 1999., С.17.



11. The main reason for migration is economic.<sup>6</sup>

We can see that in these laws of migration the main reasons for population migration are developed in relation to the good infrastructure of the regions, the development of economic and financial spheres.

The processes of population migration have been studied by representatives of various fields, and G.Iontsev has created an integrated classification of theoretical interpretations of migration by analyzing local and foreign sources. According to him, 17 different theoretical approaches to migration processes have been identified, which are economic, pure migration, demographic, political, historical approaches.<sup>7</sup>

To date, population migration has also been studied by local researchers, and according to the analytical results conducted by V.A.Ibragimov, there are 36 different approaches to the concept of migration in local publications.<sup>8</sup>

Of course, the above considerations do not fully cover the concept of migration. Because the concept of migration is a very broad concept, each research school sheds light on the theory of migration based on its field.

As for the term “migrant”, there is no universally accepted definition of the term “migrant”. The International Organization for Migration has developed the following definition for its purposes: “Migrant is a general term not defined in international law that reflects the general unprofessional interpretation of a person leaving his or her place of residence temporarily or permanently and for various reasons within a country or across an international border”.<sup>9</sup>

The United Nations considers "any person who changes their country of residence" to be an international migrant. The UN definition excludes migration caused by “holidays, visits to friends and relatives, business, medical treatment and religious visits”. In summary, there is no consensus on the term “migrant” and its definitions.

Today, labor migration is becoming increasingly global and topical. Particular attention is paid to strengthening interstate cooperation to improve this area and the effective use of labor resources, based on the identification of specific areas of international labor relations in the world. In particular, it is important to rationally organize labor migration, the introduction of "smart regulation" models in this area.<sup>10</sup>

According to the territorial structure, migration is divided into internal (within the territory of one country) and external (migration from one state to another). The increase in demand for new areas from densely populated areas within the country, as well as the infrastructure of cities relative to rural areas, leads to the emergence and development of internal migration due to the well-being of labor resources.

<sup>6</sup> Абдурахмонов Қ. Меҳнат иқтисодияёти назарияси ва амалиёти. Дарслик Т., 2019. – Б.297-298.

<sup>7</sup> Игорьян Д.И. Теория и практика исследования миграции населения. – Москва: Наука, 2011. – С. 181.

<sup>8</sup> Иброҳимов В.А. Международная миграция населения: теория и история изучения. – Ташкент, 2013. – С. 69.

<sup>9</sup> Migratsiya sohasidagi atamalar lug'ati. Xalqaro migratsiya huquqi. XMgT (Glossary on Migration. International Migration Law. IOM) 2019. 130-131 b.

<sup>10</sup> Мусоев.Б.Т. Ўзбекистонда меҳнат муносабатларини коллизия-хуқуқий тартибга солишнинг амаллаштириши: Yurid. fan, nomz. Dis. ... avtoref. – Toshkent, 2018. – 5 b.;

According to international research, people crossing the administrative territory of the state for various purposes (study, work, travel) are motivated to carry out external migration.

Uzbekistan has been actively involved in international migration since independence. As L.P.Maksakova said: “External migration relations serve as a bridge connecting Uzbekistan with the rest of the world. If in the days of the former Soviet Union migration was mainly connected with Russia and neighboring Central Asian countries, today its geography has expanded unprecedentedly. Every year, migration flows affect tens of thousands of people, the scale of which is sometimes increasing and sometimes decreasing. In general, the migration processes observed in Uzbekistan today have in common with the migration processes in all countries of the world”.<sup>11</sup>

Accordingly, taking into account the full participation of its citizens in the migration process in the international arena, the full use of their rights and freedoms and the growing role of public authorities in the systematic organization of safe migration, re-establish systematic regulation and implementation should be put. According to D.N.Dzhakhongirova: “Labor migration has begun to play an increasingly important role in solving the problem of employment in the country.”<sup>12</sup>

This will play an important role in the development of the Uzbek diaspora in some CIS countries, including Russia, Ukraine and the Baltic states, the United States, Turkey and some European countries, and the establishment of close ties with Uzbekistan after the collapse of the former Soviet Union.

Uzbekistan pays special attention to citizens involved in external migration and a number of measures are being taken. Decree No.5785 of August 20, 2019 “On measures to further strengthen the guarantees of protection of citizens of the Republic of Uzbekistan and their family members working temporarily abroad” was also adopted.

In our opinion, the role of relevant public administration bodies in the implementation of state control over internal and external migration processes is great. Accordingly, we believe that one of the key issues is to strengthen the control of public administration in the field of migration and to ensure the compatibility of these bodies.

The migration of a population to another country for temporary or permanent residence is called emigration. Immigration is the movement of people from one country to another to work. The difference between these two cases is called the migration balance.

Today, in the management of migration processes, it is necessary to develop an effective and modern public administration by combining the interests of the state with the interests of the individual. However, given that some aspects of the interests of the countries supplying labor and the countries receiving it do not coincide, it is advisable to approach it from the point of view of immigration and emigration in establishing state management of migration processes.

---

<sup>11</sup>Максакова Л.П. Миграция населения: проблемы регулирования. Т., ИД «Эльденур», 2001., С.5.П

<sup>12</sup>Джахонгирова Д.Н. О совместной деятельности профсоюзов Узбекистана с органами власти и работодателями в сфере занятости населения Республики. Сб. Материалик научно-практической конференции по теме: “Проблемы занятости и трудовой миграции в странах ЕвразЭС». Т., 2006., С.16-17.

While immigration has a positive character for the development of national diasporas, emigration is a social phenomenon that leads to the extinction of diasporas. In the process of emigration, the diaspora tends to return to their historical homeland.

From the point of view of immigration, models of state management of migration processes have been developed, and the management of migration processes in the host recipient countries is divided into American, French and German models. The American model (in the U.S. and Canada) emphasizes the promotion of human rights abused refugees, the legalization of illegal migrants, and their integration into American society. The French model (in France and the UK) differs by a networked system of admission, accommodation and integration of refugees from different countries into French society, with the “jus solis”, i.e. the principle of birth, taking precedence in granting citizenship. The German model (in Germany and Southern European countries) focuses on the admission of ethnic Germans to Germany and their subsequent integration into German society, and the principle of “jus sanguinis,” i.e., the origin of a particular ethnic group, is a priority in determining migrant citizenship.<sup>13</sup>

We believe that through the above models for managing immigration processes, states can select ways to work with their respective national diasporas based on their needs.

At the same time, in recent years, there is a “scoring system” or “selective approach” of public administration in the field of migration.<sup>14</sup> This system is currently the main solution in the selection of qualified migrants to address socio-economic issues such as geopolitical, i.e. the accumulation of human capital through the placement of migrants in sparsely populated areas, demographic (population growth). In our opinion, this approach can also be used to strengthen the activities of national diasporas.

L.H.Isakov noted that to date, the scientific community has not come to a clear conclusion on the models of management of emigration processes. When we refer to the official documents of international organizations, we can see that they are categorized on the basis of certain criteria, although not divided into specific models, or descriptions of what a “good governance model” would look like.<sup>15</sup>

However, there are international standards and approaches to the management of migration processes by international organizations, such as the UN Sustainable Development Goals, the ILO “Fundamentals of Migration Management”.

Based on the approaches to the above-mentioned models of public administration in the field of migration, we believe that it is necessary to create an environment for Uzbekistan in the management and regulation of general processes of immigration and emigration, on the basis of which the relevant government agencies interact. The migration sector in Uzbekistan is regulated and managed by several competent authorities. Therefore, it would be expedient to take the Agency for External Labor Migration under the Ministry of Employment and Labor Relations of

---

<sup>13</sup>Исоқов Л.Х. Миграция жараёнларини бошқаришнинг замонавий моделлари // Юрист ахборотномаси – Вестник юриста – Lawyer herald. № 4 (2020), Б. 153–160.

<sup>14</sup>Wahba, Jackline. Selection, Selection, Selection: the Impact of Return Migration. Journal of Population Economics, vol. 28, no. 3, 2015.

<sup>15</sup>Исоқов Л.Х. Миграция жараёнларини бошқаришнинг замонавий моделлари // Юрист ахборотномаси – Вестник юриста – Lawyer herald. № 4 (2020), Б. 155.

the Republic of Uzbekistan out of the ministry's control, to establish a special state agency for migration management and to work with the Uzbek diaspora abroad.

Today, there are 1 billion people in the world. people are participants in migration processes, of which 270 mln. one is working outside his own state.

The use of modern information technologies in the establishment of a system of orderly management of migration processes by government agencies creates favorable conditions for the competent authorities and migrants.

The Ministry of Employment and Labor Relations of the Republic of Uzbekistan launched the electronic program "Labor-migration" in 2019 to provide social support to citizens wishing to work abroad and create favorable conditions for them to legally work abroad. 310,503 citizens are registered.<sup>16</sup> Under this program:

Providing online information to citizens wishing to work abroad on the rules of stay in the country of employment, labor, social, housing and living conditions, legal aspects of concluding employment contracts with foreign employers, as well as financial assistance measures established by law;

the possibility of remote application by migrant workers in difficult situations abroad and in need of assistance;

provides information on the activities of external labor migration agencies and private employment agencies, including the types and prices of services they provide, vacancies available to foreign employers, as well as the procedure for employment in these jobs.

In our opinion, this e-program interacts with the government and citizens and serves to form a database of the competent authorities on the geography of employment of migrant workers, their areas of activity and types.

However, we can see that there are a number of systemic problems in this electronic program. For example, we can see that currently the system does not provide for the registration of migrants with a passport, and there is no system to take into account the needs of women working temporarily abroad.

In order to improve the functioning of the electronic program, we consider it expedient to expand the range of services used in the process of orderly employment of migrant workers and their legal and social assistance through "Labor-migration". The widespread use of information technology in the field of migration plays an important role in ensuring open and transparent relations between government agencies and citizens in accordance with the law, in satisfying the requests of people with disabilities.

In the international arena, we can see that migration processes are taking place in all countries of the world, and a large number of migrants are moving to economically developed countries. In these cases, the issues related to migration and work with the Uzbek diaspora abroad cause the following problems:

*First*, the number of citizens of the Republic of Uzbekistan living abroad and entering into labor relations is growing from year to year. Most citizens have entered the right of permanent

---

<sup>16</sup> Labor labormigration dasturi. <https://labormigration.uz/>

residence in foreign countries or have acquired foreign citizenship. The system for monitoring these processes and working with current and former citizens of Uzbekistan is not well established. Therefore, it is recommended to promote the establishment of non-governmental and non-profit organizations serving the interests of the Republic of Uzbekistan in foreign countries (especially Russia, Turkey, the United States) and to develop systematic mechanisms for working with the Uzbek diaspora.

*Second*, effective economic and legal measures to prevent and combat illegal labor migration must be developed and communicated to the population and employers. It is necessary to widely promote illegal labor migration, its practical and legal consequences, increase knowledge in the field of legal aspects of external labor migration of citizens, the formation of the necessary legal culture.

The analysis shows that the crime of trafficking in human beings is often caused by the desire of the poor to work illegally outside the country, and criminal elements deceive people due to inexperience, lack of legal knowledge and gaps in our existing laws. they manage to complicate it through fraud.<sup>17</sup>

*Third*, it is necessary to ensure the effective implementation of a unified technological approach to the introduction of information technology and communications in public administration, in particular, to increase the interaction of separate departmental information systems and resources related to migration. As a result, the process of integrating them into a single information space will be improved. As an example, the website migratsion.uz of the Agency for External Labor Migration and the website Labor migratsion.uz of the Ministry of Employment and Labor Relations have the same goals, so it would be appropriate to strengthen or merge the two official websites of the country.

*Fourth*, on the official websites of the state, which are often used by migrants in finding employment and other migration issues, in particular, migration.uz and labor migration.uz, it is necessary to regularly and simply post normative documents on labor legislation of the countries with the largest number of migrants. appropriate This, in turn, will greatly increase the legal awareness of citizens wishing to go abroad and provide them with great practical assistance in the full realization of their rights and freedoms, as well as their obligations abroad when necessary.

#### REFERENCES:

1. *Smith A.* Exploration of the nature and origins of the richness of peoples. –Moscow: 1976.- 332 p.
2. *Marshall A.* Principles of economic science. V 3-x tomax. – Moscow: Izdatelskaya group “Progress”, 1993.
3. *Kayumov AA* Socio-geographical bases of formation and development of labor resources of Uzbekistan. Author's abstract g.f.d. - T., 1994, 406 .; *Ata-Mirzaev O.* The potential of rural-urban youth migration in Uzbekistan. M .: 1999. 28h .; *Nazarova H-M.* The role of population migration in family development. Risola. T., 1999; *Rasulova DV* Improving the

---

<sup>17</sup>*Tursunov Y.* Tashqi mehnat migratsiyasi va uning huquqiy asoslarini rivojlantirish istiqbollari. Adliya vazirligi. Toshkent davlat yuridik institut. 2012.138-bet.

- theoretical and methodological basis of labor migration in the system of market relations. Author's abstract. i.f.d. - T., 2010, 40
4. Akhiezer A. Migration and urbanization in the CIS and Baltic states in the 90s. Ed. Z. A. Zayonchkovskoy, M. 1999, p. 17.
  5. Abdurahmonov K. Labor economics theory and operation. Darslik T., 2019. - B. 297-298.
  6. Igor'yan D.I. Theory and practice of population migration research. –Moscow: Nauka, 2011. - P. 181.
  7. Ibroximov V.A. International population migration: theory and history of study. - Tashkent, 2013. - P. 69.
  8. Migratsiya sohasidagi atamalar lug'ati. Xalqaro migratsiya huquqi. XMgT (Glossary on Migration. International Migration Law. IOM) 2019. 130-131 b.
  9. Musaev.BT Improving labor law in Uzbekistan): Yurid. fan, nomz. Dis. ... avtoref. - Tashkent, 2018. - 5 p .;
  10. Maksakova L.P. Population migration: problems of regulation. T., Publishing House "Eldenor", 2001., p.5.II
  11. Jakhongirova D.N. On the joint activities of the trade unions of Uzbekistan with the authorities and employers in the field of employment of the population of the Republic. Sat. Materials of the scientific-practical conference on the topic: “Problems of employment and labor migration in the EurAsEC countries”. T., 2006., pp. 16-17.
  12. Isokov L.Kh. Modern models of migration management // Lawyer's Bulletin - Lawyer's Herald. № 4 (2020), b. 153–160.
  13. *Wahba, Jackline*. Selection, Selection, Selection: the Impact of Return Migration. Journal of Population Economics, vol. 28, no. 3, 2015.
  14. Isokov L.Kh. Modern models of migration management // Lawyer's Bulletin - Lawyer's Herald. № 4 (2020), b. 155.Labor labormigration dasturi. <https://labormigration.uz/>
  15. Tursunov Y. External labor migration and prospects for the development of its legal framework. Ministry of justice. Tashkent State Law Institute. 2012.



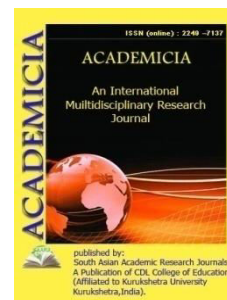

DOI: **10.5958/2249-7137.2021.01956.X**

## THE RESULTS OF EXPERIMENTS THE WIDTH OF THE SOIL DEEPER LIKE GOUGEAND ITS IMPACT ON STUDYING PERFORMANCE

**Tuxtakuziev A\* ; Khasanov U.I\*\* ; Ochilov M.Z\*\*\***

\* Professor,

Doctor of technical sciences,  
Scientific–research institute of agricultural mechanization,  
UZBEKISTAN

Email id: abduosalim\_1950@mail.ru

\*\*External doctorate student,

Bukhara branch of the Tashkent Institute of Irrigation and,  
Agricultural Mechanization Engineers,  
UZBEKISTAN

Email id: Ulugbek.hasanov.1989@mail.ru

\*\*\*Student,

Bukhara branch of the Tashkent Institute of Irrigation and,  
Agricultural Mechanization Engineers,  
UZBEKISTAN

Email: achilovnuriddinjon1994@gmail.com

### ABSTRACT

*This article describes the results of experiments on improving the design of energy-saving, deepening plow and studying the effect of the width of the trench depth on its performance, which allows to soften the subsoil without compaction, along with plowing.*

**KEYWORDS:** *Plow, Overtuner, Soil Deepener, Softener Like Gouge, Longitudinal Beam, Lock, Drive Underlayment, Berch Compensation, Energy Consumption, Crushing Quality, Compacted Walls Furrows.*

### INTRODUCTION

Modern science for mechanization of agriculture of the republic, increase of productivity of agricultural crops to ensure the implementation of the Resolution of the President of the Republic of Uzbekistan Sh. and the application of modern techniques and technologies, aimed at the

effective use of technical achievements, extensive scientific and innovative work aimed at improving the existing ones [1].

In order to produce a higher yield than any other crop, the soil must be treated and leveled before planting. When cultivating the land, the main focus should be on protecting the soil and restoring its fertility. For this purpose, traditional and resource-efficient methods of tillage are used. Which method to use is chosen according to local conditions.

Traditionally, the main tillage is carried out by plowing the soil deep (more than 30 cm) with a plow. When working with a plow, the top layer of soil is cut off and moved to the side and turned at a certain angle. As a result of the overturning, the cut stalk layer is deformed and crushed, the soil structure is restored, weed seeds and remnants and insects are buried, and the lower, humus-rich layer of soil is removed to the surface.

In irrigated lands, intensive tillage technology is used to harvest 2-3 times. This leads to repeated introduction of machine-tractor units, including drive units, into the field. As a result, the top layer of soil crumbles to dust, and the density of the bottom layer increases. In addition, when the soil is plowed to the same depth for several years with a plow, an over-compacted “berch compensation” appears at the bottom of the plow, preventing plant root development and water absorption. It is impossible to get high yields from such lands. This is why resource-saving methods of tillage and soil protection technologies are becoming more widespread around the world.

Based on the above, one of the most pressing issues in the agricultural sector is to reduce the energy consumption of this process by improving the basic process of tillage, ie the technological process of deepening the subsoil with plowing [2].

Advanced earthing plug frame 1, suspension device 2, overturner 3 and longitudinal beam 7 locks 8 are used to loosen the plow to a depth of 10-15 cm from the cutting line of the plow, depending on the location of the driving berch layer. (picture1).

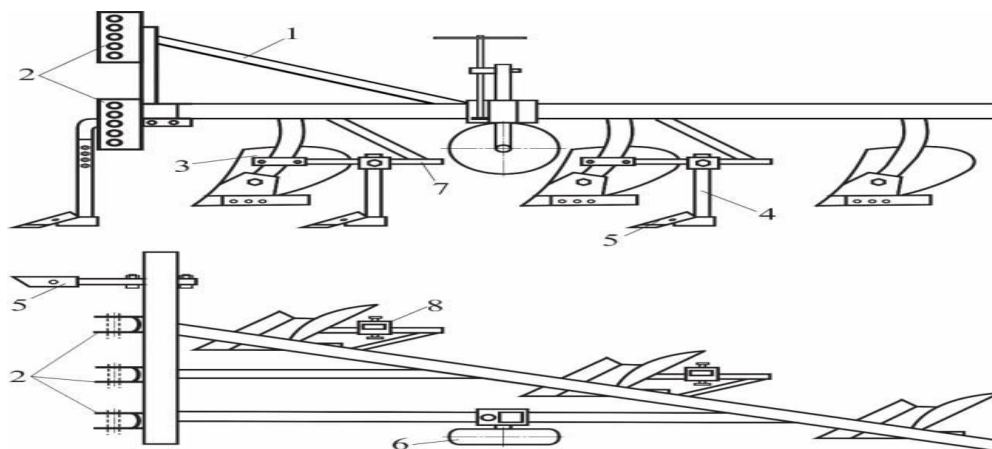

1 frame, 2 suspension, 3 overturners, 4 columns, 5 softeners like gouge, 6 support wheels, 7 longitudinal beams, 8 locks.

**Picture 1. Structural scheme of the improved soil-deepening plug**

Based on the results of theoretical research, the width of the excavation scanner in the conduct of

these experiments. 10 mm with interval 40 mm and 80 mm changed to.

Picture 2 shows the appearance of the scans, which vary in width.

The depth of tillage specified in the experiments is 15 cm, the angle of penetration of the screed into the soil is  $30^\circ$  and speeds of 6 and 8 km / h were set.

The main indicators in the study of the width of the working body were the height of the compacted wall formed at the bottom of the softened layer and its resistance to gravity. In addition, the degree of soil compaction, the depth of tillage, and its standard deviation were obtained.

The results of the experiments are shown in Figures 3,4,5.

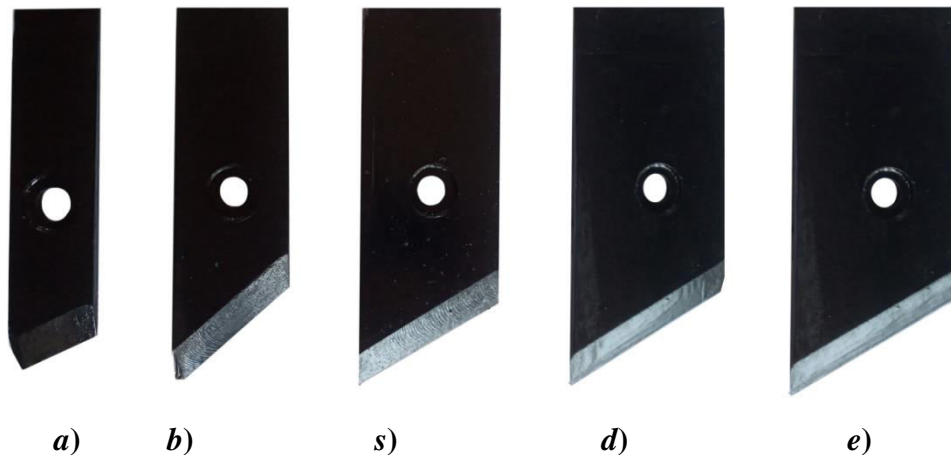

**Figure 2. The widths were 40 (a), 50 (b), 60 (c), 70 (d) and 80 (e) mm scans**

An increase in the width of the working body leads to a deterioration in the quality of soil compaction, ie the size of the treated layer 100 mm greater than and 10050 mm increase in the amount of lumps (fractions) in the interval, size 50 mm and the number of fractions smaller than This can be explained by the fact that as the width of the working body increases, the deformation zone of the soil increases and the probability of moving large lumps increases. An improvement in the quality of soil compaction was observed with increasing movement speed.

The width of the working body so that the height of the compacted arch formed at the bottom of the softened layer is not minimal or at all 60 mm as long as it should not be less than 60 mm less than the height of the edge is significant, complete softening of the treated layer is not provided, its physical and mechanical properties deteriorate. It should also be noted that the increase in speed from 6.0 km / h to 8 km / h did not have a significant effect on the height of the walls compacted.

As the width of the working body increased, at both speeds its resistance to gravity increased according to the law of straight lines.

The height of the compacted walls, the degree of compaction of the soil and the resistance of the working body to gravity

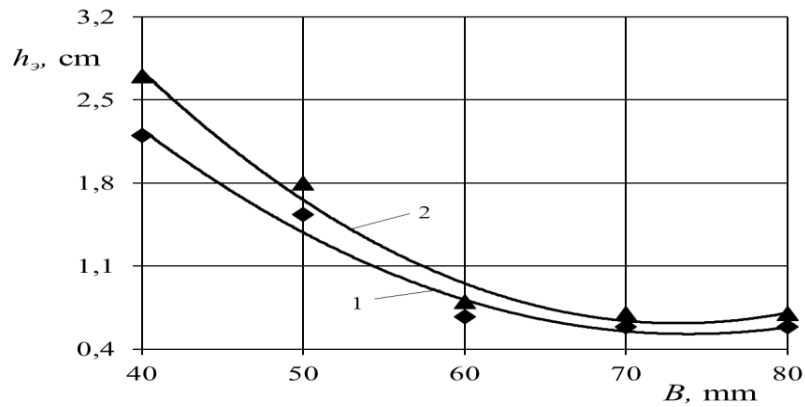

1-6 km / h; 2-8 km / h

Figure 3. Graph of the change in the height ( $h_e$ ) of the walls compacted depending on the width of the working body (V)

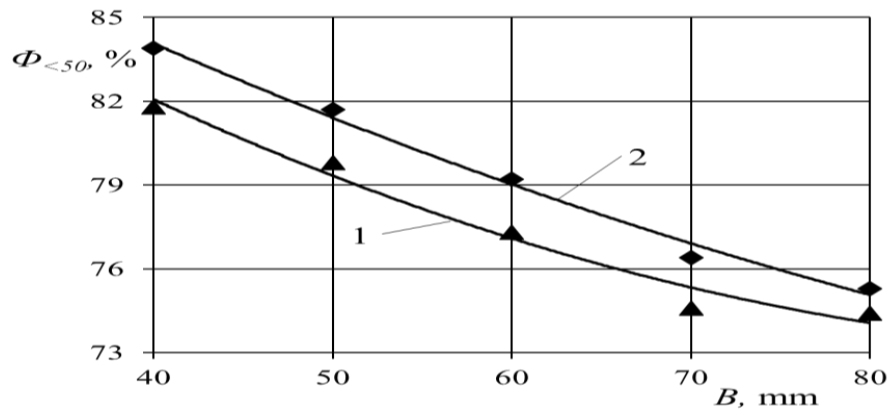

1-6 km / h; 2-8 km / h

Picture 4. Graph of change of soil compaction rate ( $\Phi < 50$ ) depending on the width of the working body (V)

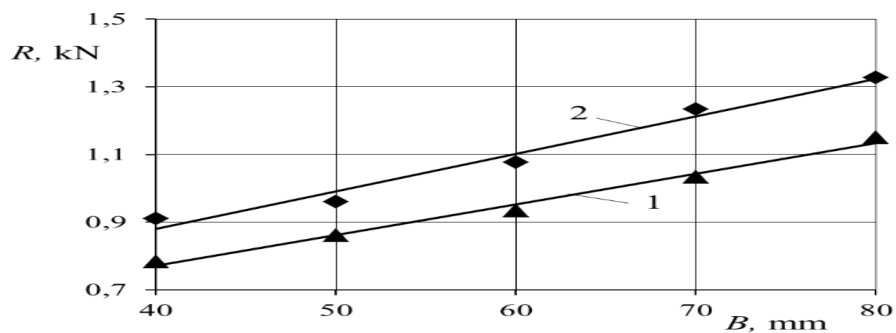

1-6 km / h; 2-8 km / h

Picture 5. Graph of change of gravity resistance (R) of a working body depending on its width (V)

The change in width can be expressed by the following empirical formulas:

a) when the unit speed is 6.0 km / h

$$he = 10.957 - 0.2824V + 0.0019 V^2, \text{ m} \quad (R^2 = 0.9841); \quad (1)$$

$$F < 50 = 97.837 - 0.4914V + 0.0024 V^2, \% \quad (R^2 = 0.9765); \quad (2)$$

$$R = 0.408 + 0.00907 V, \text{ kN} \quad (R^2 = 0.9895), \quad (3)$$

b) when the unit speed is 8.0 km / h

$$he = 8.7334 - 0.2222V + 0.0015 V^2, \text{ m} \quad (R^2 = 0.9776); \quad (4)$$

$$F < 50 = 97.414 - 0.3879V + 0.0014V^2, \% \quad (R^2 = 0.9911); \quad (5)$$

$$R = 0.4373 - 0.01107 V, \text{ kN} \quad (R^2 = 0.9767). \quad (6)$$

where V is the width of the excavator shaft (V = 40-80 mm).

Studies have shown that the values determined by empirical formulas differ by more than 3.4 percent from the values obtained in the experiments.

#### REFERENCES:

1. Resolution of the President of the Republic of Uzbekistan Sh. Mirziyoyev "On additional measures to further increase the level of technical equipment of agriculture" No PP-3459. January 4, 2018.
2. Murtazoev A.N. Interim report on the project of young scientists on "Substantiation of improved depth parameters for plows in basic tillage". 2018 y.
3. UzDSt 3193: 2017 "Testing of agricultural machinery. Method of energy evaluation of machines" // Official publication. - Tashkent, 2017. - 21 p.
4. Augambaev M., Ivanov A.Z., Terexov Yu.I. Base planning of scientific- research experiments. - Tashkent: Teacher, 1993. - 336 p.
5. Spirin N.A., Lavrov V.V. Methods of planning and processing the results of engineering experiments. - Ekaterinburg: GOU VPO Ural State Technical University. - UPI, 2004. - 258 p.



**ACADEMICIA**  
**An International**  
**Multidisciplinary**  
**Research Journal**  
 (Double Blind Refereed & Peer Reviewed Journal)

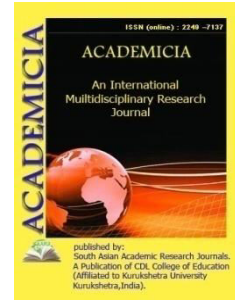

**DOI: 10.5958/2249-7137.2021.01957.1**

## MENTAL HEALTH PROBLEMS AMONG AIRCREW

**Yeliseyev N.A\***

\*Head of educational department,  
 The Higher military Aviation school the Republic of UZBEKISTAN

### ABSTRACT

*This article has discussed individual differences in personality and mental health, and common ways in how people react to different stressors in life. We have established that when the experienced level of stress exceeds the amount the person is able to cope with, various emotional, cognitive, and physiological reactions emerge. These reactions are of significance to one's general health condition, work achievements, performance, and job satisfaction. Stress has both short-term and long-term effects on the individual, and it is important to be familiar with these effects for one's own sake and because most aviation professions demand significant cooperation with colleagues and others. The article has mostly related to persons working in aviation; however, passenger issues have been described to a certain extent.*

**KEYWORDS:** *Stress, Aviation Personnel, Mental Health Problems, Disorders, Flight Safety, Aviation Psychologist, Human Factor, Risk And Protective Factors, Environmental Influences.*

### I. INTRODUCTION

An important part of psychology is the study of variations in how we think, feel, and react. Although it is important to be aware of such variations, there are a number of commonly shared patterns in terms of reactions to dramatic and stressful events. Hence, mental health problems and disorders among pilots, ATCOs, and other types of personnel in aviation may impair performance and therefore be a threat to flight safety. Following the German wings Flight 925 accident<sup>18</sup> where a pilot deliberately flew a commercial aircraft into the ground, the topic has been discussed by many including the European Cockpit Association (ECA), the European Association for Aviation Psychologists, and also the European Aero medical Association. These three organizations have collaborated and issued a joint statement in order to promote mental

<sup>18</sup>BEA (Bureau d'Enquetes et d'Analyses pour la securitel'aviationcivile). 2016. Final Report of the March 2015 Accident of Airbus A320, D-AIPX. Retrieved from: [https://www.bea.aero/uploads/tx\\_elydbrapports/BEA2015-0125.en-LR.pdf](https://www.bea.aero/uploads/tx_elydbrapports/BEA2015-0125.en-LR.pdf)



health and openness and to support pilots who need help to deal with mental health issues (see, e.g., eaap.net). The Aerospace Medical Association (AsMA) has twice issued recommendations related to mental health among pilots following accidents attributed to severe mental health problems and with updated recommendations after the German wings accident in 2015<sup>19</sup>. The expert group stated that serious mental health disorders (e.g., psychosis) are relatively rare and their onset is difficult to predict, and that preventive efforts should be aimed at more common mental health problems such as depression, anxiety, and substance misuse. They have also stated that barriers toward discussions about mental health problems between the aero medical examiner and the pilot should be recognized, and the awareness should be raised about the topic among aircrew, their families and flight organizations. They have also suggested that mental health should be assessed as part of the initial pilot selection and recurrent for pilots who have a history of mental health problems but that routinely screening for serious mental health disorders is probably not effective. There may be many reasons why a pilot may be reluctant to discuss mental health problems with the examining physician during the annual medical assessment, including fear of losing his or her license with both personal and financial costs as a result. This may prevent the pilot from receiving adequate and timely help, and this could potentially make the problems worse and prolong the time for recovery. More could probably be done to increase knowledge about mental health problems and reduce stigma so that more pilots and other professionals working in aviation report mental health problems, get treatment, and return to work. This would probably increase individual well-being, but also promote safety. Stigma has been seen as composed of three aspects:

-knowledge (ignorance),

-attitudes (prejudice),

- behavior (discrimination)<sup>20</sup>. Perceived stigma may prevent help-seeking and also put an additional burden on the person experiencing mental health problems. As a preventive measure, peer support programs (PSPs) have been suggested. These programs may include a safe zone where pilots can receive confidential counseling and support from peers, and if needed be referred to treatment.

## II. MAIN PART

The FFM traits measure normal variations in important personality traits where people differ in terms of how extroverted or conscientious they are. Personality traits are related to many important outcomes including training and work performance. Personality traits are also linked to mental health problems such as depression, anxiety, and substance use disorders<sup>21</sup>. This applies especially to neuroticism and conscientiousness where the largest differences between groups diagnosed with a mental health disorder and control groups were detected. Scoring high

<sup>19</sup>Aerospace Medical Association (AsMA). 2012. Pilot mental health: Expert working group recommendations. *Aviation, Space and Environmental Medicine* 83:1184–1185. Aerospace Medical Association (AsMA). 2016. Pilot mental health: Expert working group recommendations—Revised 2015. *Aerospace Medicine and Human Performance* 87: 505–507.

<sup>20</sup>Evans-Lacko, S., Little K., Meltzer H., Rose, D., Rhydderch, D., Henderson, C., and Thornicroft, G. 2010. Development and psychometric properties of the Mental Health Knowledge Schedule. *Canadian Journal of Psychiatry* 55: 440–448

<sup>21</sup>Kotov, R., Gamez, W., Schmidt, F., and Watson, D. 2010. Linking “big” personality traits to anxiety, depressive, and substance use disorders: A meta-analysis. *Psychological Bulletin* 136: 768–821.

on neuroticism and low on conscientiousness may be seen as risk factors associated with many mental health disorders. Meta-analyses of longitudinal studies<sup>22</sup> have indicated that neuroticism represents a risk that exists prior to the development of common mental health disorders. Certain constellations of personality traits may therefore be seen as constituting a vulnerability factor for developing mental health problems rather than stemming from the same underlying cause. Mental health has been defined by WHO<sup>23</sup> as "...a state of well-being in which every individual realizes his or her own potential, can cope with the normal stresses of life, can work productively and fruitfully, and is able to make a contribution to her or his community." This means that everyone has a mental health, and that it is more than the absence of mental disorders or problems. For an individual, it may vary over time, and it is a vital part of a person's health in general. There are many different types of mental health problems and disorders. They differ in terms of severity, how common they are, and also in terms of causes. Around 20% of the world's population has some form of mental health problem or disorder, and only a small percentage receive professional help from mental health services for their problems. Mental disorders are characterized by abnormal behavior, thoughts, and feelings, which may result in problems at work and in relation to other people. In most cases, mental health problems are caused by many contributing factors including genetic, biological, and environmental influences and stressors. Some of these influences or factors may have a negative impact on mental health and may be labeled risk factors whereas others have the opposite impact and are called protective factors. Risk and protective factors may be both individual and environmental, and may interact in different ways. Individual factors could include personality traits and intelligence, lifestyle, and the use of alcohol, and environmental factors could include family- and work-related factors. Having a family may be protective as social support is in most cases a protective factor, but family life can also be a cause for worry and conflicts and thus constitute a risk factor. Correspondingly, having a meaningful job may contribute to an individual's self-esteem and coping, but also sometimes be a source of stress and burden. Environmental influences may together with an individual vulnerability cause mental health problems, and there are also some environmental influences, for example, exposure to trauma, that may cause mental health problems without any individual vulnerability. In most cases, mental health disorders and problems result from a complex interplay between individual and environmental influences.

Different types of treatment for mental health problems exist depending on the nature of the problem. It may include medications as well as more psychosocial treatments such as cognitive therapy or behavioral therapy. The choice of therapy should rely on the best available research evidence of what actually works. Ideally, there should be studies documenting that a certain type of treatment is effective in reducing symptoms in groups of patients compared to control groups; for example, that cognitive therapy is effective in reducing depression among patients suffering from major depression compared to a control group or to other types of treatment. If there are

---

<sup>22</sup>Jeronimus, B.F., Kotov, R., Riese, H., and Ormel, J. 2016. Neuroticism's prospective association with mental disorders halves after adjustment for baseline symptoms and psychiatric history, but the adjusted association hardly decays with time: A meta-analysis on 59 longitudinal/prospective studies with 443 313 participants. *Psychological Medicine* 46: 2883–2906.

<sup>23</sup>World Health Organization (WHO). 2013. *Mental Health Action Plan 2013-2020*. Geneva, Switzerland: Author. Retrieved from: [http://apps.who.int/iris/bitstream/10665/89966/1/9789241506021\\_eng.pdf?ua=1](http://apps.who.int/iris/bitstream/10665/89966/1/9789241506021_eng.pdf?ua=1) World Health Organization (WHO). 2016. *ICD-10: International Statistical Classification of Diseases and Related Health Problems*. Geneva, Switzerland: Author.

many studies supporting the effectiveness of a certain type of therapy, then these can be summarized either through systematic reviews or meta-analyses. The Cochrane Collaboration ([www.cochranelibrary.com](http://www.cochranelibrary.com)) is an international organization that conducts systematic reviews that may be used as the basis for selecting the best available therapy. In many countries, these types of reviews are used as the basis for forming guidelines for what type of treatment should be offered for both medical and mental health problems. For some types of mental health problems, there is solid evidence, whereas for other types of illnesses there is less convincing evidence. The term evidence-based practice is frequently used by both psychiatrists and clinical psychologists and means that the treatment offered should be based on research evidence, clinical expertise, and the clients or patients' wishes, values, and needs<sup>24</sup>. In addition to different types of treatment for mental health problems, there is also an increased focus on prevention and health promotion. Mental health promotion refers to activities or interventions that aim at strengthening protective factors such as resilience and coping skills but also creating supportive environments<sup>25</sup>. Different types of prevention exist, and may be directed at everyone; for example, everyone working in the aviation industry where the purpose is to prevent a specific problem (e.g., alcohol abuse). This strategy is labeled universal prevention, and instead of targeting a specific group, the intervention is for everyone. One universal preventive measure related to alcohol would be to restrict access to alcohol. There are other types of prevention, labeled selective and indicated where the intervention is targeted either toward people at risk (selective prevention) or people who have symptoms or early signs of a problem (indicated prevention). Ideally, there should be a system that covers health promotion, prevention, and treatment, as indicated in Figure 1.

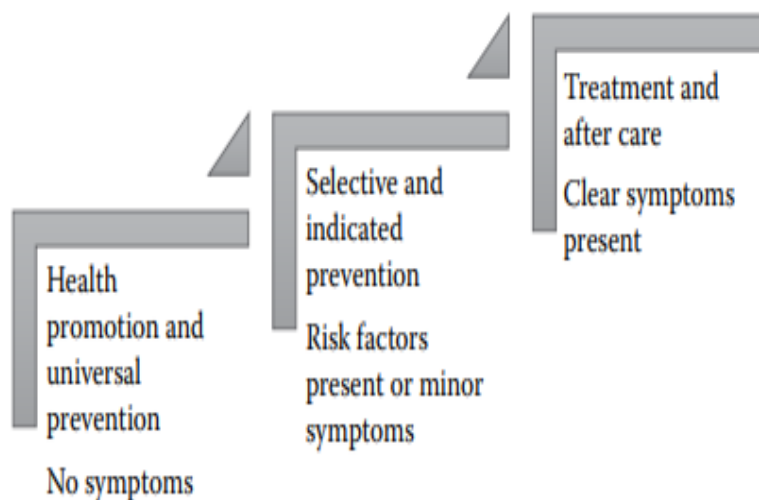

**Figure 1.** How to promote good mental health

### III. RESULTS AND DISCUSSIONS

<sup>24</sup>Sackett, D.L., Rosenberg, W.M., Gray, J.A., Haynes, R.B., and Richardson, W.S. 1996. Evidence based medicine: What it is and what it isn't. *British Medical Journal* 312(7023): 71–72.

<sup>25</sup>Barry, M. and Jenkins, R. 2007. *Implementing Mental Health Promotion*. New York, NY: Churchill Livingstone.

There are several systems for diagnosing and classifying mental disorders such as the DSM-5 (American Psychiatric Association 2013), which is probably the most widely used system in addition to the ICD-10 (International Statistical Classification of Diseases and Related Health Problems) developed by the World Health Organization<sup>26</sup>. The DSM-5 system includes a list of diagnostic categories: depressive disorders, schizophrenia and other psychotic disorders, trauma and stressor-related disorders, personality disorders, and substance-related and addictive disorders. Many of these diagnostic categories have several symptoms that need to present over a certain time period and result in a lowered level of functioning before the diagnosis can be determined. In addition, significant psychosocial and contextual features also need to be considered when diagnosing a person. This is usually done by conducting a clinical structured interview, and it may sometimes be supplemented with specific tests for assessing, for example, depressive symptoms or neuropsychological tests to examine cognitive impairment. A precise diagnosis requires cooperation from the person being interviewed, and unless the person is willing to discuss symptoms and report problems, assigning a correct diagnosis becomes very difficult for the clinician. When determining if a person suffers from a mental health disorder, it is important to rule out alternative explanations such as the symptoms being caused by a medical condition or the use of substances/medications. A person may, after losing a loved or going through a difficult breakup, display many different symptoms including depressive symptoms, anger, sleeping problems, and loss of appetite, without this constituting a disorder. Pilots, like most people, are not immune to life stressors and hardship and may experience reactions to life events and also experience mental health problems and disorders. Another way of classifying mental health disorders is between severe mental health disorders versus minor mental health problems. Psychotic disorders such as schizophrenia or bipolar disorders are more severe and are associated with a loss of contact with reality, lack of insight in the disorder, and many other symptoms including reduced functioning in major areas such as work and family life. These types of disorders are relatively rare, and the estimated lifetime prevalence for schizophrenia is between 0.30% and 0.70% and for any type of psychotic disorder is 3.5%<sup>27</sup>. For major depression, the prevalence is much more common, and in a year, almost 7% of the population may experience a major depressive disorder.

A person may suffer simultaneously from several different disorders, for example, both anxiety and depression or having an eating disorder in addition to a personality disorder. This phenomenon is referred to as comorbidity and may make the diagnosis and treatment more difficult. The advantage of such classification system like DSM-5 or other similar systems is that a correct diagnosis is a necessary requirement for choosing the best treatment. One disadvantage is that people may feel stigmatized by being assigned to a diagnostic category as mental health problems are still associated with a lack of knowledge and misconceptions about the cause and treatment options.

---

<sup>26</sup>World Health Organization (WHO). 2013. Mental Health Action Plan 2013-2020. Geneva, Switzerland: Author. Retrieved from: [http://apps.who.int/iris/bitstream/10665/89966/1/9789241506021\\_eng.pdf?ua=1](http://apps.who.int/iris/bitstream/10665/89966/1/9789241506021_eng.pdf?ua=1) World Health Organization (WHO). 2016. ICD-10: International Statistical Classification of Diseases and Related Health Problems. Geneva, Switzerland: Author.

<sup>27</sup>Perälä, J., Suvisaari, J., Saarni, S.I., Kuoppasalmi, K., Isometsä, E., Pirkola, S., Partonen T., et al. 2007. Lifetime prevalence of psychotic and bipolar I disorders in a general population. *Archives of General Psychiatry* 64: 19–28

We are continually bombarded with influences, expectations, and demands placed on us by our surroundings. Work commitments or the lack of time and resources to complete tasks are typical examples. Both paid work and unpaid work (e.g., caring for family members) are applicable factors in this regard. To meet social demands or solve work-related tasks, the individual relies on different sets of resources, including knowledge, experience, and personal attributes. Some theories describe stress as the result of factors or elements that have a negative impact on the individual; for example, distracting noise or pressure at work (stimulus-based theories), while other theories are concerned with the consequences of stress, such as various emotional and physical reactions (response-based theories). The latter tradition is exemplified by Selye<sup>28</sup>. He describes a general stress response that is valid for everyone and consists of three phases: the alarm phase, the resistance phase, and the exhaustion phase. A more modern understanding requires stress to be regarded as the interaction between demands and the resources available to the individual. When demands placed on an individual exceed his or her resources, stress develops. In these interaction models, an important point is that the person must evaluate the demands and consider whether or not these demands exceed his or her resources. Due to this cognitive evaluation, what one individual considers a stressor is not necessarily considered a stressor by someone else<sup>29</sup>. Balance between external demands and personal attributes is perceived as challenging and satisfying to the individual<sup>30</sup>, whereas imbalance is a precursor to emotional, physical, and behavioral consequences. Frankenhaeuser's biopsychosocial model (depicted in Figure 2) delineates the relationship between stress and health. In that model, the person is subjected to various demands, such as intense workloads, time constraints, shift work, problems, or conflicts. The person relates this to his or her resources, including experience, physical and mental health, personal abilities, and, potentially, external support. If demands surpasses the person's resources, stress ensues, accompanied by both psychological and physiological reactions. Immediately, various stress hormones are released into the body (adrenaline, noradrenaline, and cortisol). These hormones produce a number of advantageous effects in precarious situations; however, problems may arise if the individual is exposed to these effects for an extended period of time. If a person is continually stressed, or if there is not enough time to rest, the body is unable to normalize the physiological reactions in time for the next work session. Stress is also an unpleasant experience, with short-term and long-term consequences for the affected person's productivity.

---

<sup>28</sup>Selye, H. 1976. *The Stress of Life*. New York, NY: McGraw Hill  
Lazarus, R. 1976. *Pattern of Adjustment*. McGraw-Hill: New York.

<sup>29</sup>Lazarus, R. 1976. *Pattern of Adjustment*. McGraw-Hill: New York.

<sup>30</sup>Frankenhaeuser, M. 1991. The psychophysiology of sex differences as related to occupational status. In Frankenhaeuser, M., Lundberg, U., and Chesney, M. (Eds.), *Women, Work, and Health. Stress and Opportunities* (pp. 39–61). New York, NY: Plenum Press.



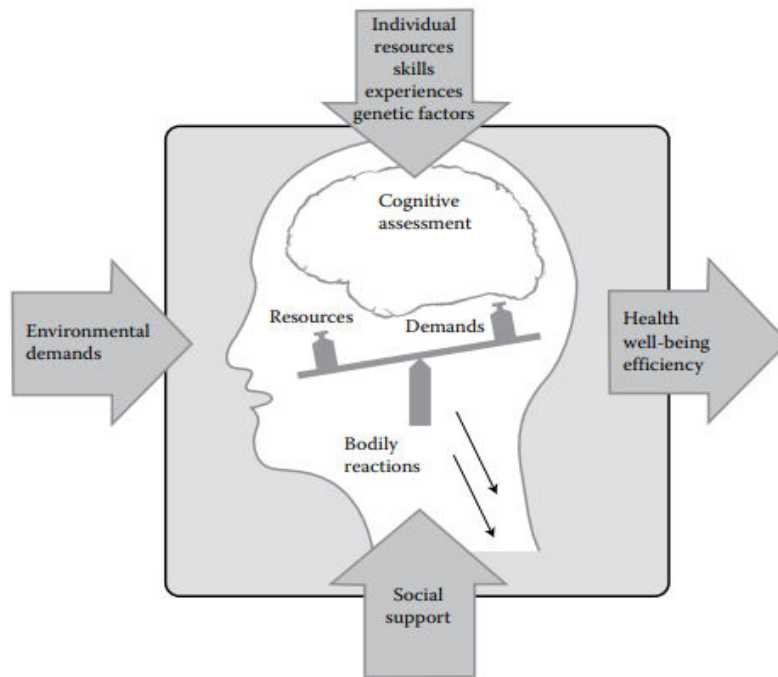

**Figure 2.** The biopsychosocial stress model. (With kind permission from Springer Science + Business Media: *Women. Work and Health. Stress Opportunities*, the psychophysiology of sex differences as related to occupational status, 1991, pp.39-61, Frankenhaeuser, M., New York: Plenum Press )

#### IV. CONCLUSION

There are other models that describe work-related stress, such as Karasek's demand-control model<sup>31</sup>, which describes how stress relates to various consequences such as health risks and behavior within the organization. In this model, work-related demands are described as "high" or "low," and, similarly, the individual's ability to affect or control the situation is deemed "high" or "low." Combining high demands with low levels of control increases the risk of psychological impacts and physical illness, such as cardiovascular diseases<sup>32</sup>. On the other hand, combining high demands and a high level of control encourages learning and has a motivational effect. Later expansions on this model have pointed out that social support, such as assistance and encouragement by colleagues, may reduce stress and minimize risks associated with negative consequences of stress. There are several forms of social support, such as care and empathy, as well as assistance of a more practical nature, and being applauded for doing a good job. Keeping in mind that stress results from an appraisal process, and that the same situation may result in stress for one person but not for another, there are some Environmental demands Health well-being efficiency Bodily reactions Resources Demands Cognitive assessment Individual resources skills experiences genetic factors Social support Figure 2. A comprehensive review by

<sup>31</sup>Karasek, R.A. and Theorell, T. 1990. *Healthy Work: Stress, Productivity, and the Reconstruction of Working Life*. New York, NY: Basic Books.

<sup>32</sup>Yoshimasu, K. 2001. Relation of type A behavior pattern and job-related psychosocial factors to non-fatal myocardial infarction: A case-control study of Japanese male workers and women. *Psychosomatic Medicine* 63: 797-804



Albuquerque and Fonseca<sup>33</sup> lists a number of stressors that may be a factor for pilots but also for other types of personnel in aviation. These include physical/physiological stressors, and job-related stressors such as difficult working conditions including pressure toward reducing costs in the aviation industry and a typical employment. The third group of stressors is individual stressors related to managing family life, shift work, and other responsibilities. Different types of stressors may add up, especially if they occur simultaneously, and the combined impact may be too much to handle for the individual. Different coping strategies for managing stress among pilots have been outlined by Eriksen and Bor<sup>34</sup> and include individual strategies for reducing stress such as living healthy, sleep hygiene, exercise, relaxation techniques, and having interests outside work. In addition, they describe work-related strategies that may be used to manage workload and establish boundaries between paid work and private life.

## REFERENCES:

1. Aerospace Medical Association (AsMA). 2012. Pilot mental health: Expert working group recommendations. *Aviation, Space and Environmental Medicine* 83:1184–1185. Aerospace Medical Association (AsMA). 2016. Pilot mental health: Expert working group recommendations—Revised 2015. *Aerospace Medicine and Human Performance* 87: 505–507.
2. Albuquerque, C. and Fonseca, M. 2017. Psychosocial stressors associated with being a pilot. In Bor R., Eriksen, C. Oakes M., and Scragg P. (Eds.), *Pilot Mental Health Assessment and Support* (pp. 287–308). New York, NY: Routledge.
3. American Psychiatric Association (APA). 2013. *Diagnosics and Statistical Manual of Mental Disorders*, 5th ed. Arlington, VA: American Psychiatric Publishing
4. Barry, M. and Jenkins, R. 2007. *Implementing Mental Health Promotion*. New York, NY: Churchill Livingstone.
5. BEA (Bureau d'Enquetes et d'Analyses pour la securitel'aviationcivile). 2016. Final Report of the March 2015 Accident of Airbus A320, D-AIPX. Retrieved from: [https://www.bea.aero/uploads/tx\\_elydrapports/BEA2015-0125.en-LR.pdf](https://www.bea.aero/uploads/tx_elydrapports/BEA2015-0125.en-LR.pdf)
6. Eriksen, C. and Bor, R. 2017. Promoting good psychological health amongst pilots: Coping strategies for identifying and managing stress to reduce risk of mental health problems and improve performance at work. In Bor, R., Eriksen, C., Oakes, M., and Scragg, P. (Eds.), *Pilot Mental Health Assessment and Support* (pp. 309–324). New York, NY: Routledge.
7. Evans-Lacko, S., Little K., Meltzer H., Rose, D., Rhydderch, D., Henderson, C., and Thornicroft, G. 2010. Development and psychometric properties of the Mental Health Knowledge Schedule. *CanadianJournalofPsychiatry* 55: 440–448

---

<sup>33</sup>Albuquerque, C. and Fonseca, M. 2017. Psychosocial stressors associated with being a pilot. In Bor R., Eriksen, C. Oakes M., and Scragg P. (Eds.), *Pilot Mental Health Assessment and Support* (pp. 287–308). New York, NY: Routledge.

<sup>34</sup>Eriksen, C. and Bor, R. 2017. Promoting good psychological health amongst pilots: Coping strategies for identifying and managing stress to reduce risk of mental health problems and improve performance at work. In Bor, R., Eriksen, C., Oakes, M., and Scragg, P. (Eds.), *Pilot Mental Health Assessment and Support* (pp. 309–324). New York, NY: Routledge.

8. Frankenhaeuser, M. 1991. The psychophysiology of sex differences as related to occupational status. In Frankenaueuser, M., Lundberg, U., and Chesney, M. (Eds.), *Women, Work, and Health. Stress and Opportunities* (pp. 39–61). New York, NY: Plenum Press.
9. Karasek, R.A. and Theorell, T. 1990. *Healthy Work: Stress, Productivity, and the Reconstruction of Working Life*. New York, NY: Basic Books.
10. Kotov, R., Gamez, W., Schmidt, F., and Watson, D. 2010. Linking “big” personality traits to anxiety, depressive, and substance use disorders: A meta-analysis. *Psychological Bulletin* 136: 768–821.
11. Jeronimus, B.F., Kotov, R., Riese, H., and Ormel, J. 2016. Neuroticism’s prospective association with mental disorders halves after adjustment for baseline symptoms and psychiatric history, but the adjusted association hardly decays with time: A meta-analysis on 59 longitudinal/prospective studies with 443 313 participants. *Psychological Medicine* 46: 2883–2906.
12. Lazarus, R. 1976. *Pattern of Adjustment*. McGraw-Hill: New York.
13. Perälä, J., Suvisaari, J., Saarni, S.I., Kuoppasalmi, K., Isometsä, E., Pirkola, S., Partonen T., et al. 2007. Lifetime prevalence of psychotic and bipolar I disorders in a general population. *Archives of General Psychiatry* 64: 19–28
14. Sackett, D.L., Rosenberg, W.M., Gray, J.A., Haynes, R.B., and Richardson, W.S. 1996. Evidence based medicine: What it is and what it isn’t. *British Medical Journal* 312(7023): 71–72.
15. Selye, H. 1976. *The Stress of Life*. New York, NY: McGraw Hill Lazarus, R. 1976. *Pattern of Adjustment*. McGraw-Hill: New York.
16. World Health Organization (WHO). 2013. *Mental Health Action Plan 2013-2020*. Geneva, Switzerland: Author. Retrieved from: [http://apps.who.int/iris/bitstream/10665/89966/1/9789241506021\\_eng.pdf?ua=1](http://apps.who.int/iris/bitstream/10665/89966/1/9789241506021_eng.pdf?ua=1) World Health Organization (WHO). 2016. *ICD-10: International Statistical Classification of Diseases and Related Health Problems*. Geneva, Switzerland: Author.
17. Yoshimasu, K. 2001. Relation of type A behavior pattern and job-related psychosocial factors to non-fatal myocardial infarction: A case-control study of Japanese male workers and women. *Psychosomatic Medicine* 63: 797–804

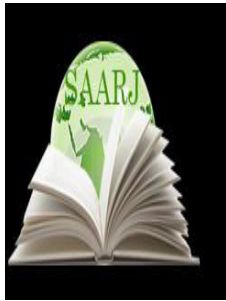

**ACADEMICIA**  
**An International**  
**Multidisciplinary**  
**Research Journal**  
 (Double Blind Refereed & Peer Reviewed Journal)

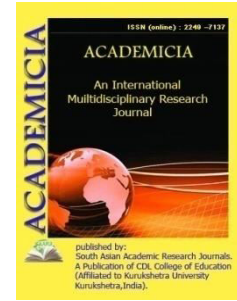

**DOI: 10.5958/2249-7137.2021.01958.3**

**ECONOMIC IMPACT OF KISAN CREDIT CARD SCHEME ON  
 PROFITABILITY OF CROPS IN DEORIA DISTRICT OF UTTAR  
 PRADESH**

**Hraday Kumar\*; Awadhesh Kumar\*\*; Vijay Kumar Pal\*\*\*;  
 Satish Chandra Verma\*\*\*\*; Vinay Kumar Rawat\*\*\*\*\***

<sup>1,3,4</sup>Assistant Professor,

Department of Agricultural Economics & Statistics, Baba Raghav Das Post Graduate College,  
 Deoria, Deen Dayal Upadhyay Gorakhpur University, Gorakhpur, Uttar Pradesh, INDIA

Email id: hradaykumarbhu@gmail.com

\*\*Assistant Professor,

Department of Soil Conservation, Baba Raghav Das Post Graduate College, Deoria, Deen Dayal  
 Upadhyay Gorakhpur University, Gorakhpur, Uttar Pradesh, INDIA

Email id: awadheshy427@gmail.com

\*\*\*\*\*Associate Professor & Head,

Department of Agricultural Economics & Statistics, Baba Raghav Das Post Graduate College,  
 Deoria, Deen Dayal Upadhyay Gorakhpur University, Gorakhpur, Uttar Pradesh, INDIA

**ABSTRACT**

*The study was confined to the Deoria district of eastern Uttar Pradesh. The district was selected purposively. 60 farmers were selected by simple random sampling method. The present investigation is a comparative study between KCC holders and non-KCC holders. Therefore, two types of respondents were required 30 KCC and 30 non-KCC holders. The KCC holders were those who were benefited under the scheme during the period of 2019-2020. The overall cost of sugarcane was worked out to be Rs 114762.58 in KCC holders which were high compared to non-KCC holders Rs.107979.88. Gross income per hectare was Rs.225812.10 in KCC holders more compared to Rs. 200904.60 in non-KCC holders per hectare. Net income was Rs.111049.52 in KCC holders more compared to Rs. 92924.72 in non KCC holders per hectare. The overall cost of paddy was worked out to be Rs 57287.10 in the KCC holders which was highest compared to non-KCC holders Rs.53729.90. Gross income per hectare was Rs.117784.16 in KCC holders and Rs. 104580.09 in non KCC holders per hectare. Net income*

was Rs.52028.23 in KCC holders and Rs.42741.66 in non- KCC holders per hectare. The overall cost of wheat was worked out to be Rs 53850.21 which was high compared to non- KCC holders Rs.51720.97. Gross income per hectare was Rs.82920.79 in KCC holders more compared to Rs.77409.10 in non- KCC holders per hectare. Net income was Rs.29070.58 in KCC holders more compared to Rs. 25688.13 in non KCC holders per hectare. Impact of the KCC scheme on production, productivity and income increased under all the categories after availing credit under KCC scheme. It can also be seen that productivity of the sugarcane, paddy and wheat crop was found increased with increase in farm size.

**KEYWORDS:** Kisan Credit Card, KCC Holders, Non-KCC Holders, Cost Of Production, Cost Concepts, Farm Income Measures

## INTRODUCTION

To sustain the growth in agriculture, credit plays a vital role and also key factor in agriculture development. Agriculture development and growth are possible only if adequate capital and proper technology are used. The change in the technology of agriculture enhanced the need for credit. Credit also acts as a catalyst, to move the farmers from traditional agriculture to modern agriculture. Kisan Credit Card (KCC) is one of the many innovative products designed by NABARD with an objective to enable farmers to meet their credit requirements, preferably production credit, from financial institutions in a timely and hassle-free manner. The KCC scheme which was introduced in 14<sup>th</sup> August 1998, has gone through several changes since then and now incorporates many new features over and above the financing of crop production requirements, viz. consumption, expenditure, maintenance of farm assets, term loan for agriculture and allied activities, coverage of KCC holders under Personal Accident Insurance Scheme (PAIS) and very recently the coverage of KCC holders under Atal Pension Yojana. Today KCC is considered to be one of the most convenient banking products for farmers. Government of India introduced the KCC scheme in 1998 as an innovative credit delivery mechanism to enable the farmers to meet their production credit requirements in a timely and hassle-free manner.

The state government has given special emphasis in Agriculture Policy on availability of crop loan through Kisan Credit Card to all eligible farmers of the state in view of ensuring easy availability of farm inputs and increasing utilization of crop loan in it. Government of India has accepted the recommendations of task force organized by Government of India, Ministry of Finance, Department of Finance Services to review the scheme of Kisan Credit Card and convert it into smart card cum debit card.

**Objectives of Kisan Credit Card (KCC) scheme;** to provide adequate and timely credit to farmers, to meet short term production needs for the cultivation of crops for the entire year, to augment flow of credit to farmers, especially small, medium, tenant farmers, oral lessees, share croppers/individuals taking up farm activities, to build mutual trust and confidence between bank and target group. to provide food security to vulnerable section by enhancing agricultural production, productivity and livelihood promotion through joint liability group mechanism, to meet contingency expenditure for ancillary expenses as medical, education and other needs.

**Salient features of the Kisan Credit Card (KCC) Scheme;** eligible farmers to be provided with a Kisan Credit Card and a pass book or card-cum pass book. Revolving cash credit facility involving any number of drawals and repayments within the limit. Limit to be fixed on the basis of operational land holding, cropping pattern and scale of finance. Entire production credit needs for full year plus ancillary activities related to crop production to be considered while fixing limit. Sub-limits to cover short term, medium term as well as term credit are fixed at the discretion of banks. Card valid for 3 to 5 years subject to annual review. As incentive for good performance, credit limits could be enhanced to take care of increase in costs, change in cropping pattern, etc. Each drawal to be repaid within a maximum period of 12 months Conversion/ reschedulement of loans also permissible in case of damage to crops due to natural calamities, Security, margin, rate of interest etc. as per RBI norms. Operations may be through issuing branch (and also PACS in the case of Cooperative Banks) through other designated branches at the discretion of bank, Withdrawals through slips/cheques accompanied by card and passbook.

**Revision in Kisan Credit Card Scheme,** Recommendations of Working Group constituted by Government of India, under the Chairmanship of Shri T M Bhasin, Chairman & Managing Director, Indian Bank on redesigning of KCC scheme to make it Smart Card-cum-Debit Card were accepted and a revised KCC scheme has been introduced in April 2012.

**The salient features of the revised KCC scheme are as under;** assessment of crop loan component based on the scale of finance for the crop plus insurance premium x Extent of area cultivated + 10% of the limit towards post-harvest / household/consumption requirements + 20% of limit towards maintenance expenses of farm assets. Validity period of KCC and its periodic review may be decided by the bank. Margin may be decided by the bank. The repayment period may be fixed by banks as per the anticipated harvesting and maturity period for the crops for which a loan has been granted. Interest subvention /incentive for prompt repayment to be available as per the Government of India and State Government norms. One time documentation at the time of first availment and thereafter simple declaration (about crops raised/ proposed) by farmer. KCC cum SB account instead of farmers having two separate accounts. The credit balance in KCC cum SB accounts to be allowed to fetch interest at saving bank rate. Disbursement through various delivery channels, including ICT driven channels like ATM/ PoS/ Mobile handsets.

NABARD, in January 2013 set up special project unit – Kisan Credit Card (SPUKCC) with a mandate for encouraging co-operative banks and Regional Rural Banks across the country to issue RuPay KCC debit cards. The core objective of the unit is to facilitate issuance of cards by these banks through guidance, coordination with national payment corporation with national payment corporation of India and interaction with sponsor banks of RRBS and Co-operative banks. The overall goal is to develop cashless ecosystem by enabling the community to avail all new banking facilities at par with urban area of the country. The SPU undertakes policy formulations, capacity building and networking with the various stake holders to achieve above objectives. The new KCC guidelines specify that all KCC customers should have the facility of withdrawal through ATM/Debit cards. NABARD, with a view to facilitate early action in this direction, as already floated schemes providing financial support to RRBS and cooperatives for issuing these cards.



The cost of cultivation was more for KCC holders when compare to control farmers i.e. Non-KCC farmers. The cost of cultivation per acre was higher by 8.2 per cent for paddy KCC farmers then Non-KCC farmers. The cost of cultivation was higher for KCC farmers on account of comparatively higher doses of application of inputs resulting in higher yield by KCC farmers as compared to the Non- KCC farmers under paddy crop (Parta and Sahu, 2011). The average cost of cultivation is more in case of KCC holders (Rs. 65886.27 /ha) compare to non KCC holders (Rs. 65184.43 /ha) and net returns obtained by KCC holders is more (Rs. 121483.36 /ha) as against non KCC holders (Rs. 119606.91 /ha) for sugarcane Sajane *et al.*, 2011). The cost of cultivation for paddy was Rs 11100 to 14500 for KCC farmers and Rs 10500 to 13000 was for non KCC holders. The cost of cultivation per acre was higher by 7.6 per cent for paddy. The cost of cultivation was higher for KCC holders compare to non-KCC holders under paddy cultivation (Olekar, 2012). The KCC beneficiaries incurred higher cost in cultivation of paddy by 14.21 per cent 19.89 per cent 11.10 per cent and 12.22 per cent in case of marginal, small medium and large farms, respectively when compare to Non-KCC beneficiaries (Patel, 2012). The cost of cultivation of KCC holders farmers was higher (Rs. 31225.9 /ha) as compared to Non-KCC holders (Rs. 27611.8 /ha) and net returns obtained by KCC farmers is more (Rs. 3649.2 /ha) as against the Non-KCC farmers (Rs. 2565.5 /ha) (Prakash, 2013). The cost of cultivation of banana for KCC holder farmers was higher (Rs. 132516) as compared to Non-KCC holder farmers (Rs.117774). It was due to application of higher amount of purchased inputs facilitated by the borrowed money and gross returns per hectare for banana crop were also higher for KCC holder when compared to Non-KCC holders (Bhangale and Sarodae, 2015).

## MATERIAL AND METHODS

The study was confined in eastern Uttar Pradesh which comprises five divisions Viz. Varanasi, Gorakhpur, Azamgarh, Mirzapur and Basti. Gorakhpur division consists of four districts namely –Gorakhpur, Deoria, Kushinagar and Maharajganj. Deoria district was selected purposively. A list of all 16 blocks was prepared on the basis of KCC holder's area. One block namely Baitalpur block was purposively selected for the study. There are 91 villages in Baitalpur block. 3 villages were selected on the basis of the important crops grown in the study area under Wheat, Rice and Sugarcane cultivation. The present investigation is a comparative study between KCC holders and non-KCC holders. Therefore, two types of respondents were required. 30 KCC and 30 non-KCC. In study area selection of respondents is done by random sampling method. Each village farmers are divided in four categories according to their land holding i.e. marginal, small, medium and large farmers. In each village 20 farmers (10 KCC and 10 non-KCC) will be identified for the field study therefore total sample size 60 (30 KCC and 30 non- KCC) from selected village. The KCC farmers were those who were benefited under the scheme during the period of 2019-20 considered for the investigation. Prior to actual selection of targeted respondents, a comprehensive list of KCC respondents and non-KCC respondents was prepared. The farm level data and required information of KCC holders and non-KCC holders pertaining to crop year 2019-2020, was during March-April. The collected data were compiled and analyzed with a tabular method of analysis, simple statistical tools such as arithmetical averages and percentages were worked out for the purpose of interpretation of results. To work out the cost of cultivation standard method of cost cultivation employed by Commission for Agricultural Costs and Prices (CACP), directorate of economics and statistics, government of India was adopted.

### Cost concepts as per the CACP classification



The cost concepts approach to farm casting is widely used in India. To work out the cost of cultivation standard method of cost cultivation employed by commission for agricultural costs and prices (CACP), directorate of economics and statistics, government of India was adopted. These include Cost A<sub>1</sub>, Cost A<sub>2</sub>, Cost B<sub>1</sub> Cost B<sub>2</sub> Cost C<sub>1</sub>, Cost C<sub>2</sub>, and CostC<sub>3</sub>. Various costs have been worked out by applying following method:

**Cost A<sub>1</sub>:** all actual expenses in cash and kind incurred in production. CostA<sub>1</sub>: consists of following 14 costs items:

1. Value of hired human labour (permanent & casual).
2. Value of owned bullock labour.
3. Value of hired bullock labour.
4. Value of owned machine labour.
5. Hired machinery charges
6. Value of fertilizers.
7. Value of manure (produced farm and purchased).
8. Value of seed (both farm- produced and purchased).
9. Value of insecticides, pesticides and fungicides.
10. , irrigation charges (both owned and hired tube wells pumping sets etc.).
11. Canal water charges.
12. Land revenue, cesses and other taxes.
13. Depreciation on farm implements and machinery (both bullock drawn & worked with human labour, farm building and farm machinery).
14. , interest on the working capital..

**Cost A<sub>2</sub>:** Cost A<sub>1</sub> + Actual rent paid for leased in land

**Cost B<sub>1</sub>:** Cost A<sub>1</sub>+ Interest on value of owned fixed capital assets (excluding land)

**Cost B<sub>2</sub>:** Cost B<sub>1</sub> + rental value of owned land

**Cost C<sub>1</sub>:** Cost B<sub>1</sub>+ imputed value of family labour

**Cost C<sub>2</sub>:** Cost B<sub>2</sub> + imputed value of family labour

**Cost C<sub>3</sub>:** Cost C<sub>2</sub>+ 10 percent of cost C<sub>2</sub> to account for managerial function perform by farmer.

### **Farm income measures**

Under farm income, gross income, net income, were worked out:

**Gross income:** gross income pertains to the total value of the potato production during the year valued at the average prices of the year.

**Net income:** Net income was worked out on by deducting cost C<sub>2</sub> gross income.

**Benefit-cost ratio (BCR):** Benefit – cost ratio is obtained by ratio of total gross return to the total cost

## RESULT AND DISCUSSION

### Per hectare cost and returns of sugarcane production

The Table 1 shows that the overall cost incurred by the KCC beneficiaries was worked out to be Rs 114762.58 which was high compared to non KCC beneficiaries Rs.107979.88. Out of total cost that overall operational cost of KCC beneficiaries was Rs.71148.81 and non KCC beneficiaries was Rs. 72549.01. The fixed cost of KCC and non KCC was Rs. 36248.40 and Rs.35430.87 respectively. Total cost per hectare was higher in KCC farmers compared to non KCC farmers. This difference was mainly due to higher cost of variable input used in KCC farmers compared to non KCC farmers. Gross income obtained per hectare was more in KCC beneficiaries. It was Rs.225812.10 in KCC beneficiaries and Rs. 200904.60 in non KCC beneficiaries per hectare. But net income was more in KCC beneficiaries compared to non KCC beneficiaries. It was Rs.111049.52 in KCC beneficiaries and Rs. 92924.72 in non KCC beneficiaries per hectare. This was due to the comparatively lower expenditure on sugarcane production of non KCC beneficiaries. From Table 2. It is clear that the Cost A<sub>1</sub> and cost A<sub>2</sub> were found to be same as there was no land was taken on lease. Cost B<sub>1</sub>, cost B<sub>2</sub>, Cost C<sub>1</sub> and C<sub>2</sub> was more of KCC farmers than the non KCC farmers. From Table 3. shows that the total output of sugarcane under the KCC was 707.34 q/ha was higher than non KCC farmers 628.84 q/ha. The returns of KCC farmers are somewhat more than the non KCC farmers.

### Per hectare cost and returns of paddy production

The Table 4. indicates that the overall cost incurred by the KCC beneficiaries was worked out to be Rs 57287.10 which was highest compared to non KCC beneficiaries Rs.53729.90. Out of total cost that overall operational cost of KCC beneficiaries was Rs.38522.90 and non KCC beneficiaries was Rs. 35099.01. The fixed cost of KCC and non KCC was Rs. 18764.15 and Rs.18630.82 respectively. Total cost per hectare was higher in KCC farmers compared to non KCC farmers. This difference was mainly due to higher cost of variable input used in KCC farmers compared to non KCC farmers. From Table 5. It is clear that the Cost A<sub>1</sub> and cost A<sub>2</sub> were found to be same as there was no land was taken on lease. Cost B<sub>1</sub>, cost B<sub>2</sub>, cost C<sub>1</sub> and C<sub>2</sub> was more of KCC farmers than the non KCC farmers. The perusal of Table 6. It is clear that the total output of paddy under the KCC was 61.34q/ha was higher than non KCC farmers 56.08 q/ha. The returns of KCC farmers are somewhat more than the non KCC farmers. Gross income obtained per hectare was more in KCC beneficiaries. It was Rs.117784.16 in KCC beneficiaries and Rs. 104580.09 in non KCC beneficiaries per hectare. But net income was more in KCC beneficiaries compared to non KCC beneficiaries. It was Rs.52028.23 in KCC beneficiaries and Rs.42741.66 in non KCC beneficiaries per hectare.

### Per hectare cost and returns of wheat production

The table 7 shows that the overall cost incurred by the KCC beneficiaries was worked out to be Rs 53850.21 which was high compared to non KCC beneficiaries Rs.51720.97. Out of total cost that overall operational cost of KCC beneficiaries was Rs.35939.28 and non KCC beneficiaries was Rs.33763.02. The fixed cost of KCC and non KCC was Rs. 17910.93 and Rs.17957.97 respectively. Total cost per hectare was higher in KCC farmers compared to non KCC farmers.

This difference was mainly due to higher cost of variable input used in KCC farmers compared to non KCC farmers. From the Table 8. Shows that the Cost  $A_1$  and cost  $A_2$  were found to be same as there was no land was taken on lease. Cost  $B_1$ , cost  $B_2$ , cost  $C_1$  and  $C_2$  was more of KCC farmers than the non KCC farmers. The Table 9. shows that the total output of wheat under the KCC was 41.37q/ha was higher than non KCC farmers 37.96 q/ha. The returns of KCC farmers are somewhat more than the non KCC farmer. Gross income obtained per hectare was more in KCC beneficiaries. It was Rs.82920.79 in KCC beneficiaries and Rs.77409.10 in non KCC beneficiaries per hectare. But net income was more in KCC beneficiaries compared to non KCC beneficiaries. It was Rs.29070.58 in KCC beneficiaries and Rs. 25688.13 in non KCC beneficiaries per hectare.

**TABLE 1: COST OF CULTIVATION PER HECTARE OF SUGARCANE FOR DIFFERENT CATEGORIES OF FARMERS (RS. /HA)**

Sl. No.	Cost Items	KCC holders					Non KCC holders				
		Marginal	Small	Medium	Large	Overall	Marginal	Small	Medium	Large	Overall
<b>Operational cost</b>											
1.	Human labour	24508.17 (22.99)	23024.51 (20.87)	23854.88 (20.09)	23790.61 (19.31)	23794.54 (20.73)	23808.17 (23.78)	23024.51 (21.99)	22456.36 (20.37)	22930.91 (19.68)	23054.99 (21.35)
	a) Hired labour	6884.03 (6.45)	7308.64 (6.62)	8925.77 (7.51)	17884.22 (14.51)	10250.67 (8.93)	6884.03 (6.87)	7308.64 (6.98)	8617.82 (7.81)	12675.25 (10.87)	8871.43 (8.21)
	b) Family labour	17624.14 (16.53)	15715.87 (14.24)	14929.11 (12.57)	5906.39 (4.79)	13543.88 (11.80)	16924.14 (16.90)	15715.87 (15.01)	13838.54 (12.55)	10255.66 (8.80)	14183.55 (13.13)
2.	Sett's/ seeds	11290.66 (10.59)	12584.65 (11.40)	14688.56 (12.37)	15338.05 (12.44)	13475.48 (11.74)	10066.67 (10.05)	11433.33 (10.92)	12666.67 (11.44)	14024.04 (12.03)	12047.68 (11.15)
3.	Manure	2575.12 (2.41)	2298.78 (2.08)	2050.33 (1.72)	2045.23 (1.66)	2242.36 (1.95)	2275.05 (2.27)	2488.78 (2.37)	2023.33 (1.82)	1815.12 (1.55)	2150.57 (1.99)
4.	Fertilizers	6250.45 (5.86)	7324.56 (6.63)	8575.33 (7.22)	9523.32 (7.73)	7918.14 (6.89)	5945.04 (5.93)	6455.05 (6.16)	7366.76 (6.65)	8323.33 (7.14)	7022.54 (6.50)
5.	Plant protection	1900.65 (1.78)	2335.45 (2.11)	2536.67 (2.13)	2723.04 (2.21)	2373.95 (2.06)	1500.05 (1.49)	1878.12 (1.79)	2166.67 (1.95)	2368.78 (2.03)	1978.40 (1.83)
6.	Irrigation charges	9485.56 (8.90)	10625.55 (9.63)	12985.50 (10.93)	13084.05 (10.62)	11545.16 (10.06)	7423.33 (7.41)	8833.33 (8.43)	10368.67 (9.36)	11612.11 (9.96)	9559.36 (8.85)

7.	Machin e labour	9656.3 6 (9.06)	10456. 24 (9.47)	11068 .24 (9.32)	13023 .28 (10.57)	11051 .03 (9.62)	8636. 67 (8.63)	9862. 33 (9.42)	11888. 78 (10.74)	12818. 12 (11.00)	10801 .48 (10.00)
8.	Miscell aneous expense s	827.25 (0.77)	926.67 (0.84)	1025. 21 (0.86)	1128. 04 (0.91)	976.7 9 (0.85)	997.0 4 (0.99)	845.2 5 (0.80)	1320.1 2 (1.19)	1588.7 8 (1.36)	1187. 80 (1.10)
9.	Interest on working capital	4654.5 9 (4.36)	4870.3 4 (4.41)	5374. 93 (4.52)	5645. 89 (4.58)	5136. 43 (4.47)	4245. 64 (4.24)	4537. 44 (4.33)	4918.0 1 (4.44)	6384.8 4 (4.53)	5021. 48 (4.65)
<b>z</b>	<b>Total operati onal cost</b>	<b>71148. 81 (66.76)</b>	<b>74446. 75 (67.48)</b>	<b>82159 .65 (69.20)</b>	<b>86301 .51 (70.05)</b>	<b>78514 .18 (68.41)</b>	<b>64897 .66 (64.83)</b>	<b>69358 .15 (66.26)</b>	<b>75175. 37 (67.93)</b>	<b>80764. 87 (69.32)</b>	<b>72549 .01 (67.18)</b>
<b>Fixed costs/overhead cost</b>											
10.	Land revenue	42.00 (0.04)	42.00 (0.03)	42.00 (0.04)	42.00 (0.03)	42.00 (0.03)	42.00 (0.04)	42.00 (0.04)	42.00 (0.04)	42.00 (0.03)	42.00 (0.04)
11.	Deprecia tion	1578.7 7 (1.48)	1983. 65 (1.79)	2602. 32 (2.19)	2902. 10 (2.35)	2322. 64 (1.61)	1378. 88 (1.37)	1480. 04 (1.41)	1645.2 5 (1.48)	1866.6 7 (1.60)	1592.7 1 (1.47)
12.	Rental value of owned land	30000. 00 (28.15)	30000 .00 (27.19)	30000 .00 (25.26)	30000 .00 (24.35)	30000 .00 (26.14)	30000 .00 (29.97)	30000 .00 (28.66)	30000. 00 (27.10)	30000. 00 (25.75)	30000. 00 (27.78)
13.	Interest on fixed capital	3794.4 9 (3.56)	3843. 07 (3.84)	<b>3917. 32 (3.29)</b>	3953. 29 (3.21)	3883. 75 (3.38)	3770. 50 (3.76)	3782. 64 (3.61)	3802.4 7 (3.43)	3829.0 4 (3.28)	3796.1 6 (3.51)
	<b>Total overhea d cost</b>	<b>35415. 26 (33.23)</b>	<b>35868 .72 (32.51)</b>	<b>36561 .64 (30.79)</b>	<b>36897 .39 (29.94)</b>	<b>36248 .40 (31.58)</b>	<b>35191 .38 (35.16)</b>	<b>35304 .68 (33.73)</b>	<b>35489. 72 (32.06)</b>	<b>35737. 71 (30.67)</b>	<b>35430. 87 (32.81)</b>
	<b>Total cost</b>	<b>10656 4.07 (100.0 0)</b>	<b>11031 5.48 (100.0 0)</b>	<b>11872 1.29 (100.0 0)</b>	<b>12319 8.90 (100.0 0)</b>	<b>11476 2.58 (100.0 0)</b>	<b>10008 9.04 (100.0 0)</b>	<b>10466 2.83 (100.0 0)</b>	<b>11066 5.09 (100.0 0)</b>	<b>11650 2.58 (100.0 0)</b>	<b>10797 9.88 (100.0 0)</b>

Note: figures in the parentheses indicate percentages to total

**TABLE 2: COST OF CULTIVATION AS PER THE CACP APPROACH (RS./HA.)**

Sl.	Costs/	KCC holders	Non KCC holders
-----	--------	-------------	-----------------

No .	Category	Marg inal	Small	Medi um	Large	Over all	Marg inal	Small	Medi um	Large	Over all
1..	Cost A <sub>1</sub> (all actual expenses)	55145 .44 (47.04 )	60756 .53 (50.06 )	69874 .86 (53.50 )	83339 .22 (61.49 )	67334 .94 (53.33 )	49394 .40 (44.86 )	55164 .32 (47.91 )	63024 .08 (51.77 )	72417 .88 (56.50 )	60000 .17 (50.51 )
2.	Cost A <sub>2</sub> = Cost A <sub>1</sub> + rent paid for leased in land	55145 .44 (47.04 )	60756 .53 (50.06 )	69874 .86 (53.50 )	83339 .22 (61.49 )	67334 .94 (53.33 )	49394 .40 (44.86 )	55164 .32 (47.91 )	63024 .08 (51.77 )	72417 .88 (56.50 )	60000 .17 (50.51 )
3.	Cost B <sub>1</sub> = Cost A <sub>1</sub> +interest on value of owned fixed capital	58939 .93 (50.28 )	64599 .60 (53.23 )	73792 .18 (56.50 )	87292 .51 (64.41 )	71218 .69 (56.41 )	53164 .90 (48.28 )	58946 .96 (51.20 )	66826 .55 (54.89 )	76246 .92 (59.49 )	63796 .33 (53.71 )
4.	Cost B <sub>2</sub> = Cost B <sub>1</sub> + rental value of owned land	88939 .93 (75.87 )	94599 .60 (77.95 )	10379 2.18 (79.47 )	11729 2.51 (86.55 )	10121 8.69 (80.18 )	83164 .90 (75.53 )	88946 .96 (77.25 )	96826 .55 (79.54 )	10624 6.92 (82.90 )	93796 .33 (78.96 )
5.	Cost C <sub>1</sub> =: Cost B <sub>1</sub> + imputed value of family labour	76564 .07 (65.31 )	80315 .47 (66.19 )	88721 .29 (67.93 )	93198 .90 (68.77 )	84762 .57 (67.14 )	70089 .04 (63.66 )	74662 .83 (64.85 )	80665 .09 (66.26 )	86502 .58 (67.49 )	77979 .88 (65.65 )
6.	Cost C <sub>2</sub> = Cost B <sub>2</sub> + imputed value of family labour	<b>10656</b> <b>4.07</b> <b>(90.90 )</b>	<b>11031</b> <b>5.48</b> <b>(90.90 )</b>	<b>11872</b> <b>1.29</b> <b>(90.90 )</b>	<b>12319</b> <b>8.90</b> <b>(90.90 )</b>	<b>11476</b> <b>2.58</b> <b>(90.90 )</b>	<b>10008</b> <b>9.04</b> <b>(90.90 )</b>	<b>10466</b> <b>2.83</b> <b>(90.90 )</b>	<b>11066</b> <b>5.09</b> <b>(90.90 )</b>	<b>11650</b> <b>2.58</b> <b>(90.90 )</b>	<b>10797</b> <b>9.88</b> <b>(90.90 )</b>
7.	Cost C <sub>3</sub> = Cost C <sub>2</sub> + 10 percent of cost C <sub>2</sub> to account for managerial function perform by farmer.	<b>11722</b> <b>0.48</b> <b>(100.00 )</b>	<b>12134</b> <b>7.02</b> <b>(100.00 )</b>	<b>13059</b> <b>3.41</b> <b>(100.00 )</b>	<b>13551</b> <b>8.79</b> <b>(100.00 )</b>	<b>12623</b> <b>8.84</b> <b>(100.00 )</b>	<b>11009</b> <b>7.94</b> <b>(100.00 )</b>	<b>11512</b> <b>9.11</b> <b>(100.00 )</b>	<b>12173</b> <b>1.59</b> <b>(100.00 )</b>	<b>12815</b> <b>2.84</b> <b>(100.00 )</b>	<b>11877</b> <b>7.87</b> <b>(100.00 )</b>

Note: figures in the parentheses indicate percentages to the total cost (C<sub>3</sub>)

**TABLE 3: RETURNS FROM SUGARCANE PRODUCTION FOR DIFFERENT CATEGORIES OF FARMERS**

Sl. No.	Particulars	KCC holders					Non KCC holders				
		Marginal	Small	Medium	Large	Overall	Marginal	Small	Medium	Large	Overall
1.	Cost of cultivation (Rs./ha)	10656 4.07	1103 15.48	1187 21.29	1231 98.90	1147 62.58	1000 89.04	1046 62.83	11066 5.09	1165 02.58	1079 79.88
2.	Yield of main product (Q./ha)	667.0 4	686.6 7	721.1 2	754.5 5	707.3 4	590.2 5	615.2 3	633.3 3	676.5 4	628.8 4
3.	Yield of By product (Q./ha)	45.00	47.00	50.00	58	50.00	42.00	45.00	48.00	53.00	47.00
4.	Prices of main product (Rs./Q.)	315.0 0	315.0 0	315.0 0	315.0 0	315.0 0	315.0 0	315.0 0	315.0 0	315.0 0	315.0 0
5.	Prices of By product (Rs./Q.)	60.00	60.00	60.00	60.00	60.00	60.00	60.00	60.00	60.00	60.00
6.	Returns of main product (Rs./ha)	21011 7.60	2163 01.05	2271 52.80	2376 83.25	2228 12.10	1859 28.75	1937 97.45	19949 8.95	2131 10.10	1980 84.60
7.	Returns of By product (Rs./ha)	2700. 00	2820. 00	3120. 00	3480. 00	3000. 00	2520. 00	2700. 00	2880. 00	3300. 00	2820. 00
8.	Gross return (Rs./ha)	21281 7.60	2191 21.05	2302 72.80	2411 63.25	2258 12.10	1884 48.75	1964 97.45	20237 8.95	2164 10.10	2009 04.60
9.	Net income Rs./ha	10656 4.53	1088 05.57	1115 51.51	1179 64.35	1110 49.52	8835 9.71	9183 4.62	91713 3.86	9990 7.52	9292 4.72
10.	Cost of production (Rs./Q)	159.7 5	160.6 5	164.6 3	163.2 7	162.2 4	169.5 7	170.1 1	174.7 3	172.2 0	171.7 1
11.	B:C ratio (BCR)	1.99	1.98	1.93	1.95	1.96	1.88	1.87	1.83	1.85	1.86

Note: figures in the parentheses indicate percentages to the total cost (C<sub>3</sub>)

**TABLE 4: PER HECTARE COST INPUT OF FACTORS IN PADDY CULTIVATION (RS./HA)**

Sl.	Cost Items	KCC holders	Non KCC holders
-----	------------	-------------	-----------------



No.		Margi nal	Small	Medi um	Larg e	Overall	Margi nal	Small	Mediu m	Large	Overa ll
	<b>Operational cost</b>										
	Human labour	14008.17 (26.13)	14624.50 (26.09)	14854.88 (25.15)	14390.61 (23.80)	14469.54 (25.25)	13508.2 (26.67)	13724.4 (26.27)	13656.36 (24.77)	13330.91 (23.33)	13554.99 (25.22)
	a) Hired labour	2884.03 (5.38)	3308.64 (5.90)	5925.77 (10.03)	11884.22 (19.66)	6000.66 (10.47)	2884.03 (5.73)	3008.64 (5.76)	5217.82 (9.44)	10675.25 (18.69)	5446.43 (10.13)
	b) Family labour	11124.14 (20.75)	11315.87 (20.19)	8929.11 (15.12)	2506.39 (4.14)	8468.87 (14.78)	10624.14 (21.06)	10715.9 (20.51)	8438.54 (15.30)	2655.66 (4.64)	8108.55 (15.09)
	Seeds	2290.66 (4.27)	2384.65 (4.25)	2688.56 (4.55)	3038.05 (5.02)	2650.48 (4.53)	2066.67 (4.09)	2233.33 (4.27)	2666.67 (4.83)	2824.04 (4.94)	2447.68 (4.5)
	Manure	1575.12 (2.98)	1298.78 (2.31)	950.33 (1.60)	1045.23 (1.72)	1217.36 (2.12)	1475.05 (2.92)	988.78 (1.89)	1123.33 (2.03)	1215.12 (2.12)	1200.57 (2.28)
	Fertilizers	4950.45 (9.23)	5324.56 (9.50)	5575.33 (9.44)	6023.32 (9.96)	5468.41 (9.54)	3945.04 (7.82)	4455.05 (8.52)	5366.76 (9.73)	5923.33 (10.37)	4922.54 (9.16)
s	Plant protection	1900.65 (3.54)	2335.45 (4.16)	2536.67 (4.29)	2723.04 (4.50)	2373.95 (4.14)	800.05 (1.51)	1178.12 (2.25)	1366.67 (2.47)	1568.78 (2.74)	1228.40 (2.28)
	Irrigation charges	2485.56 (4.63)	2625.55 (4.68)	3985.50 (6.74)	4084.05 (6.75)	3295.00 (5.75)	3123.33 (6.19)	3233.33 (6.19)	3368.67 (6.11)	3612.11 (6.32)	3334.36 (6.20)
	Machine labour	4656.36 (8.68)	5456.24 (9.73)	6068.24 (10.27)	6223.28 (10.29)	5601.03 (9.77)	4036.67 (8.00)	4862.33 (9.30)	5488.78 (9.95)	6218.12 (10.88)	5151.48 (9.54)
	Miscellaneous expenses	827.25 (1.54)	926.67 (1.65)	1025.21 (1.73)	1128.04 (1.86)	976.79 (1.70)	997.04 (1.97)	845.25 (1.69)	1020.12 (1.85)	988.78 (1.73)	962.80 (1.79)
	Interest on working capital	2288.54 (4.26)	2448.34 (4.36)	2637.93 (4.46)	2705.89 (4.47)	2520.19 (4.39)	2096.64 (4.15)	2206.44 (4.22)	2384.01 (4.32)	2497.68 (4.37)	2229.19 (4.27)
z	<b>Total operational cost</b>	<b>34982.81 (65.26)</b>	<b>37424.88 (66.75)</b>	<b>40322.77 (68.2)</b>	<b>41361.55 (68.42)</b>	<b>38522.99 (67.24)</b>	<b>32048.77 (63.53)</b>	<b>33727.22 (64.57)</b>	<b>36441.44 (66.09)</b>	<b>38178.9 (66.84)</b>	<b>35099.01 (65.25)</b>

Fixed costs/Overhead cost											
Land revenue	42.00 (0.08)	42.00 (0.07)	42.00 (0.07)	42.00 (0.06)	42.00 (0.07)	42.00 (0.08)	42.00 (0.08)	42.00 (0.08)	42.00 (0.08)	42.00 (0.07)	42.00 (0.08)
Depreciation	1578.77 (2.94)	1583.65 (2.82)	1682.32 (2.84)	2002.10 (3.30)	1711.71 (2.98)	1378.88 (2.73)	1480.04 (2.83)	1645.25 (2.98)	1866.67 (3.26)	1592.71 (2.96)	
Rental value of owned land	15000 (27.98)	15000.00 (26.76)	15000.00 (25.40)	15000.00 (24.81)	15000.00 (26.18)	1500.00 (29.73)	15000.00 (28.7)	15000.00 (27.20)	15000.00 (26.26)	15000.00 (27.91)	
Interest on fixed capital	1994.49 (3.72)	1995.07 (3.55)	2006.918 (3.39)	2045.29 (3.38)	2010.45 (3.50)	1970.56 (3.90)	1982.64 (3.79)	2002.47 (3.63)	2029.04 (3.55)	1996.16 (3.71)	
<b>Total overhead cost</b>	<b>18615.26 (34.73)</b>	<b>18620.73 (37.22)</b>	<b>18731.24 (31.71)</b>	<b>19089.39 (31.57)</b>	<b>18764.155 (32.75)</b>	<b>1839.139 (36.46)</b>	<b>18504.68 (35.42)</b>	<b>18689.72 (33.90)</b>	<b>18937.71 (33.15)</b>	<b>18630.82 (34.67)</b>	
<b>Total cost</b>	<b>53598.07 (100)</b>	<b>56045.50 (100)</b>	<b>59053.89 (100)</b>	<b>60450.90 (100)</b>	<b>57287.10 (100)</b>	<b>5044.010 (100)</b>	<b>52231.80 (100)</b>	<b>55131.10 (100)</b>	<b>57116.60 (100)</b>	<b>53729.90 (100)</b>	

Note: figures in the parentheses indicate percentages to total

**TABLE 5: COST OF CULTIVATION AS PER THE CACP APPROACH (RS./HA.)**

Sl. No.	Costs/Category	KCC holders					Non KCC holders				
		Marginal	Small	Medium	Large	Overall	Marginal	Small	Medium	Large	Overall
1..	Cost A <sub>1</sub> (all actual expenses)	25479.44 (43.21)	277(44.98)	33117.91 (50.98)	40899.21 (61.50)	31807.74 (50.47)	22845.44 (41.17)	24533.34 (42.70)	29690.11 (48.96)	37431.91 (59.58)	28625.17 (48.43)
2.	Cost A <sub>2</sub> = Cost A <sub>1</sub> + rent paid for leased in land	25479.44 (43.21)	277(44.98)	33117.91 (50.98)	40899.21 (61.50)	31807.74 (50.47)	22845.44 (41.17)	24533.34 (42.70)	29690.11 (48.96)	37431.91 (59.58)	28625.17 (48.43)
3.	Cost B <sub>1</sub> = Cost A <sub>1</sub> + interest on value of owned fixed capital	27473.93 (46.59)	29729.65 (48.22)	35124.83 (54.07)	42944.50 (64.58)	33818.19 (53.66)	24816.00 (44.73)	26515.98 (46.15)	31692.58 (52.26)	39460.95 (62.80)	30621.33 (59.10)
4.	Cost B <sub>2</sub> = Cost B <sub>1</sub> + rental value	42473.93 (72.04)	44729.65 (72.55)	50124.83 (77.1)	57944.50 (87.13)	48818.19 (77.46)	39816.00 (71.76)	41515.98 (72.25)	46692.58 (76.99)	54460.95 (86.68)	45621.33 (77.19)

	of owned land )			6)	)	)	)	)	)	)	)
5.	Cost $C_1 =$ Cost $B_1 +$ imputed value of family labour	38598. 07 (65.46 )	41045. 52 (66.57)	44053 .94 (67.8 1)	45450. 89 (68.35 )	42287. 06 (67.10 )	35440. 14 (63.87 )	37231. 88 (64.80 )	40131. 12 (66.17 )	42116. 61 (67.03 )	38729. 88 (65.53 )
6.	Cost $C_2 =$ Cost $B_2 +$ imputed value of family labour	53598. 07 (90.90 )	56045. 50 (90.90)	59053 .89 (90.9 0)	60450. 90 (90.90 )	57287. 10 (90.90 )	50440. 10 (90.90 )	52231. 80 (90.90 )	55131. 10 (90.90 )	57116. 60 (90.9 0)	53729. 90 (90.90 )
7.	Cost $C_3 =$ Cost $C_2 +$ 10 percent of cost $C_2$ to account for managerial function perform by farmer.	58957. 88 (100)	61650. 07 (100)	64959 .33 (100)	66495. 979 (100)	63015. 77 (100)	55484. 15 (100)	57455. 07 (100)	60644. 23 (100)	62828. 27 (100)	59102. 87 (100)

Note: figures in the parentheses indicate percentages to the total cost ( $C_3$ )

**TABLE 6: RETURNS FROM PADDY PRODUCTION FOR DIFFERENT CATEGORIES OF FARMERS**

Sl. No.	Particulars	KCC holders					Non KCC holders				
		Mar ginal	Smal l	Medi um	Larg e	Over all	Mar ginal	Smal l	Medi um	Larg e	Over all
1.	Cost of cultivation (Rs./ha)	5359 8.07	5604 5.50	5905 3.89	6045 0.90	5728 7.10	5044 0.10	5223 1.80	55131 .10	5711 6.60	5372 9.90
2.	Yield of main product (Q./ha)	58.0 4	60.67	62.12	64.55	61.34	54.25	55.23	56.33	58.53	56.08
3.	Yield of By product (Q./ha)	50.0 0	55.00	56.00	58.00	54.75	48.00	50.00	53.00	56.00	51.75
4.	Prices of main product (Rs./Q.)	1680 .12	1720. 25	1750. 75	1815. 00	1741. 53	1600. 10	1620. 25	1700. 00	1800. 20	1680. 13

5.	Prices of By product (Rs./Q.)	200.00	200.00	200.00	200.00	200.00	200.00	200.00	200.00	200.00	200.00
6.	Returns of main product(Rs./ha)	97514.16	104367.57	108756.59	117158.25	106834.16	86805.42	89486.41	95761.00	105365.70	94230.09
7.	Returns of By product (Rs./ha)	10000.00	11000.00	11200.00	11600.00	10950.00	9600.00	10000.00	10600.00	11200.00	10350.00
8.	Gross return (Rs./ha)	107514.20	115367.60	119956.60	128758.25	117784.16	96405.42	99486.41	106361.00	116565.70	104580.09
9.	Net income Rs./ha	42791.95	48006.17	51973.54	65800.97	52028.23	35341.14	36538.63	42791.34	56793.44	42741.66
10.	Cost of production (Rs./Q)	923.46	923.77	950.64	936.49	933.92	929.77	945.71	978.71	975.85	958.09
11.	B:C ratio(BCR)	2.00	2.05	2.03	2.12	2.05	1.91	1.90	1.92	2.04	1.94

**TABLE 7: COST OF CULTIVATION PER HECTARE OF WHEAT FOR DIFFERENT CATEGORIES OF FARMERS (RS./HA)**

Sl. No.	Cost Items	KCC holders					Non KCC holders				
		Marginal	Small	Medium	Large	Overall	Marginal	Small	Medium	Large	Overall
<b>Operational cost</b>											
1.	Human labour	11757.45 (23.27)	11959.97 (22.69)	11260.36 (20.54)	12191 (21.15)	11777.43 (21.87)	9656.24 (20.09)	10398.03 (20.52)	10754.88 (20.25)	9807.39 (17.80)	10154.14 (19.63)
	a) Hired labour	3534.12 (6.99)	5828.64 (11.05)	6421.82 (11.710)	8275.25 (14.43)	6014.96 (11.16)	3325.23 (6.91)	5412.80 (10.68)	5625.77 (10.60)	6593.15 (11.97)	52.39 (10.12)
	b) Family labour	8223.33 (16.27)	6131.33 (11.63)	4838.54 (8.82)	3856.67 (6.72)	5762.46 (10.70)	6331.01 (13.17)	4985.23 (9.84)	5129.11 (9.66)	3214.24 (5.83)	4914.89 (9.50)
2.	Seed	3314.74 (6.56)	3623.55 (6.87)	3885.25 (7.08)	4225.38 (7.36)	3762.24 (6.98)	3389.15 (7.05)	3525.23 (6.95)	3965.32 (7.46)	4425.85 (8.03)	3826.38 (7.39)
3.	Manure	2375.12	2398.78	2325.12	2365.25	2366.06	2378.45	2389.16	2314.25	2464.25	2386.77

		(4.70)	(4.55)	(4.24)	(4.12)	(4.39)	(4.94)	(4.71)	(4.35)	(4.47)	(4.61)
4.	Fertilizers	3250.45 (6.43)	3324.56 (6.30)	4425.96 (8.07)	4878.20 (8.50)	3969.79 (7.37)	3125.12 (6.50)	3655.89 (7.21)	4065.23 (7.65)	5480.60 (9.95)	4081.71 (7.89)
5.	Plant protection	979.65 (1.94)	1210.45 (2.29)	1589.78 (2.89)	1678.30 (2.92)	1364.54 (2.53)	1225.40 (2.55)	1478.69 (2.92)	1535.95 (2.89)	1774.56 (3.22)	1503.65 (2.90)
6.	Irrigation charges	4285.56 (8.48)	4625.55 (8.77)	5271.90 (9.61)	5510.28 (9.60)	4923.32 (9.14)	4395.23 (9.24)	4735.78 (9.34)	5385.50 (10.14)	5723.48 (10.39)	5059.99 (9.78)
7.	Machine labour	4012.25 (7.94)	4516.26 (8.56)	4618.33 (8.42)	4890.22 (8.52)	4509.26 (8.37)	3450.78 (7.18)	3596.23 (7.09)	3610.14 (6.79)	3683.16 (6.68)	3585.07 (6.93)
8.	Miscellaneous expenses	727.25 (1.43)	849.25 (1.61)	996.12 (1.81)	1089.21 (1.89)	915.45 (1.70)	789.33 (1.64)	821.65 (1.62)	1086.68 (2.04)	1128.31 (2.04)	956.49 (1.84)
9.	Interest on working capital	2149.18 (4.25)	2275.59 (4.31)	2406.10 (4.39)	2573.81 (4.48)	2351.16 (4.36)	1988.68 (4.13)	2142.05 (4.23)	2290.26 (4.31)	2414.20 (4.38)	2208.79 (4.27)
	<b>Total operational cost</b>	<b>32851.68 (65.03)</b>	<b>34783.96 (66.00)</b>	<b>36778.92 (67.08)</b>	<b>39342.57 (68.58)</b>	<b>35939.28 (66.73)</b>	<b>30398.38 (63.25)</b>	<b>32742.71 (64.63)</b>	<b>35008.21 (65.93)</b>	<b>36902.80 (67.00)</b>	<b>33763.02 (65.27)</b>
<b>Fixed costs/overhead cost</b>											
10.	Land revenue	42.00 (0.08)	42.00 (0.08)	42.00 (0.08)	42.00 (0.07)	42.00 (0.08)	42.00 (0.08)	42.00 (0.08)	42.00 (0.08)	42.00 (0.08)	42.00 (0.08)
11.	Depreciation	729.45 (1.44)	956.25 (1.81)	1068.78 (1.94)	1045.12 (1.82)	949.90 (1.76)	725.63 (1.50)	956.90 (1.89)	1105.14 (2.08)	1179.84 (2.14)	991.87 (1.91)
12.	Rental value of owned land	15000.00 (29.69)	15000.00 (28.46)	15000.00 (27.36)	15000.00 (26.15)	15000.00 (27.85)	15000.00 (31.21)	15000.00 (29.60)	15000.00 (28.25)	15000.00 (27.23)	15000.00 (29.00)
13.	Interest on fixed capital	1892.57 (3.74)	1919.79 (3.64)	1933.29 (3.52)	1930.45 (3.36)	1919.02 (3.56)	1892.12 (3.93)	1919.87 (3.79)	1937.65 (3.64)	1946.62 (3.53)	1924.06 (3.72)
	<b>Total</b>	<b>17664</b>	<b>17918</b>	<b>18044</b>	<b>1801</b>	<b>1791</b>	<b>1765</b>	<b>1791</b>	<b>18084</b>	<b>18168</b>	<b>17957</b>

	overhead cost	.02 (34.96)	.04 (33.99)	.07 (32.91)	7.57 (31.41)	0.93 (33.26)	9.75 (36.74)	8.77 (35.36)	.80 (34.06)	.46 (32.99)	.94 (34.72)
	Total cost	50515.70 (100)	52702.00 (100)	54822.99 (100)	57360.15 (100)	53850.21 (100)	48058.12 (100)	50661.47 (100)	53093.00 (100)	55071.26 (100)	51720.97 (100)

Note: figures in the parentheses indicate percentages to total

**TABLE 8: COST OF CULTIVATION AS PER THE CACP APPROACH (RS./HA.)**

Sl. No.	Costs/ Category	KCC holders					Non KCC holders				
		Marginal	Small	Medium	Large	Overall	Marginal	Small	Medium	Large	Overall
1..	Cost A <sub>1</sub> (all actual expenses)	2539 9.80 (45.71)	2965 0.88 (51.14)	3305 1.16 (50.98)	3657 3.02 (61.50)	3116 8.72 (50.47)	2483 5.00 (41.17)	2875 6.38 (42.70)	3102 6.24 (48.96)	3491 0.40 (59.58)	2988 2.00 (48.43)
2.	Cost A <sub>2</sub> = Cost A <sub>1</sub> + rent paid for leased in land	2539 9.80 (45.71)	2965 0.88 (51.14)	3305 1.16 (50.98)	3657 3.02 (61.50)	3116 8.72 (50.47)	2483 5.00 (41.17)	2875 6.38 (42.70)	3102 6.24 (48.96)	3491 0.40 (59.58)	2988 2.00 (48.43)
3.	Cost B <sub>1</sub> = Cost A <sub>1</sub> + interest on value of owned fixed capital	2729 2.37 (49.11)	3157 0.67 (54.45)	3498 4.45 (54.07)	3850 3.47 (64.58)	3308 7.74 (53.66)	2672 7.12 (44.73)	3067 6.25 (46.15)	3296 3.89 (52.26)	3685 7.02 (62.80)	3180 6.06 (59.10)
4.	Cost B <sub>2</sub> = Cost B <sub>1</sub> + rental value of owned land	4229 2.37 (76.11)	4657 0.67 (80.33)	4998 4.45 (77.16)	5350 3.47 (87.13)	4808 7.74 (77.46)	4172 7.12 (71.76)	4567 6.25 (72.25)	4796 3.89 (76.99)	5185 7.02 (86.68)	4680 6.06 (77.19)
5.	Cost C <sub>1</sub> = Cost B <sub>1</sub> + imputed value of family labour	3551 5.70 (63.91)	3770 2.00 (66.503)	3982 2.99 (67.81)	4236 0.14 (68.35)	3885 0.20 (67.10)	3305 8.13 (63.87)	3566 1.48 (64.80)	3809 3.00 (66.17)	4007 1.26 (67.03)	3672 0.95 (65.53)
6.	Cost C <sub>2</sub> = Cost B <sub>2</sub> + imputed value of family	5051 5.70 (90.90)	5270 2.00 (90.90)	5482 2.99 (90.90)	5736 0.15 (90.90)	5385 0.21 (90.90)	4805 8.12 (90.90)	5066 1.47 (90.90)	5309 3.00 (90.90)	5507 1.26 (90.90)	5172 0.97 (90.90)



	labour										
7.	Cost $C_3$ =	5556	5797	6030	6309	5923	5286	5572	5840	6057	5689
	Cost $C_2$ + 10 percent of cost $C_2$ to account for manageria l function perform by farmer.	7.27 (100)	2.20 (100)	5.28 (100)	6.17 (100)	5.23 (100)	3.93 (100)	7.62 (100)	2.3 (100)	8.39 (100)	3.07 (100)

Note: figures in the parentheses indicate percentages to the total cost ( $C_3$ )

**TABLE 9: RETURNS FROM WHEAT PRODUCTION FOR DIFFERENT CATEGORIES OF FARMERS**

Sl. No.	Particulars	KCC holders					Non KCC holders				
		Marginal	Small	Medium	Large	Overall	Marginal	Small	Medium	Large	Overall
1.	Cost of cultivation (Rs./ha)	5051 5.70	5270 2.00	5482 2.99	5736 0.15	5385 0.21	4805 8.12	5066 1.47	53093 .00	5507 1.26	5172 0.97
2.	Yield of main product (Q./ha)	38.04	40.67	42.12	44.67	41.37	34.04	36.23	39.25	42.33	37.96
3.	Yield of By product (Q./ha)	34.00	35.00	36.00	36.00	35.25	33.00	33.00	34.00	35.00	33.75
4.	Prices of main product (Rs. /Q.)	1720. 00	1750. 00	1800. 00	1925. 00	1748. 75	1720. 00	1740. 00	1780. 00	1850. 00	1772. 50
5.	Prices of By product (Rs. /Q.)	300.0 0	300.0 0	300.0 0	300.0 0	300.0 0	300.0 0	300.0 0	300.0 0	300.0 0	300.0 0
6.	Returns of main product (Rs./ha)	6542 8.80	7117 2.50	7581 6.00	8598 9.75	7234 5.79	5854 8.80	6304 0.20	69886 5.00	7831 0.50	6728 4.10
7.	Returns of By product (Rs./ha)	1020 0.00	1050 0.00	1080 0.00	1080 0.00	1057 5.00	9900. 00	9900. 00	10200 .00	1050 0.00	1012 5.00

8.	Gross return (Rs./ha)	7562 8.80	8167 2.5	8661 6.00	9678 9.75	8292 0.79	6844 8.80	7294 0.20	80065 .00	8881 0.50	7740 9.10
9.	Net income Rs. /ha	2511 3.10	2897 0.50	3179 3.01	3942 9.60	2907 0.58	2039 0.68	2277 8.73	26972 .00	3373 9.24	2568 8.13
10.	Cost of production (Rs./Q)	1327. 96	1295. 84	1301. 59	1284. 08	1301. 67	1411. 81	1398. 32	1352. 68	1300. 99	1362. 51
11.	B:C ratio(BCR)	1:1.4 9	1:1.5 4	1:1.5 7	1:1.6 8	1:1.5 3	1:1.4 2	1:1.4 3	1:1.50	1:1.6 2	1:1.4 9

**TABLE 10: IMPACT OF KISAN CREDIT CARD SCHEME ON AGRICULTURAL PRODUCTION, PRODUCTIVITY AND INCOME OF MAJOR CROPS**

Sl. No.	Particulars /crops	Non KCC holders	KCC holders	Non KCC holders	KCC holders	Non KCC holders	KCC holders	Non KCC holders	KCC holders	Non KCC holders	KCC holders
		Marginal farmers		Small farmers		Medium farmers		Large farmers		Overall	
<b>Sugarcane</b>											
1.	Productivity (q./ha.)	590.25	667.04	615.23	686.67	633.33	721.12	676.54	754.55	628.84	707.34
2.	Gross income (Rs./ha.)	188448.75	212817.60	196497.45	219121.05	202378.95	230272	216410.10	241163.25	200904.60	225812.10
3.	Net income (Rs./ha.)	88359.71	106564.53	91834.62	111551.51	917133.86	111551.51	99907.52	117964.35	92924.72	111049.52
<b>Paddy</b>											
1.	Productivity (q./ha.)	54.25	58.04	55.23	60.67	56.33	62.12	58.33	64.55	61.34	56.08
2.	Gross income	96405.42	107514.20	99486.41	115367.60	106361.00	119956.60	116565.70	128758.25	117784.16	104580.09

	e (Rs./ha.)										
3.	Net income (Rs./ha.)	35341 .14	42791. 95	36538 .63	4800 6.17	42791 .34	5197 3.54	56793. 44	65800 .97	52028 .23	42741. 66
<b>Wheat</b>											
1.	Produ ctivity (q./ha. )	34.04	38.04	36.23	40.67	39.25	42.12	42.33	44.67	37.96	41.37
2.	Gross incom e (Rs./h a.)	68448. 80	75628. 80	72940 .20	8167 2.50	80065 .00	8661 6.00	88810. 50	96789 .75	77409 .10	82920. 79
3.	Net incom e (Rs./h a.)	20390. 68	25113. 10	22778 .73	2897 0.50	26972 .00	3179 3.01	33739. 24	39429 .60	25688 .13	29070. 58

### Impact of Kisan Credit Card Scheme on crop Production, Productivity and Income

Table 10. reveals that the impact of the KCC scheme on production, productivity and income increased under all the categories after availing credit under KCC scheme. It can also be seen that productivity of the sugarcane, paddy and wheat crop was found increased with increase in farm size. Overall Gross income of sugarcane crop per hectare was more in KCC holders. It was Rs.225812.10 in KCC holders and Rs. 200904.60 in non- KCC holders per hectare. But net income was more in KCC holders compared to non- KCC holders. It was Rs.111049.52 in KCC holders and Rs. 92924.72 in non- KCC holders per hectare. Overall Gross income paddy crop per hectare was more in KCC holders. It was Rs.117784.16 in KCC holders and Rs. 104580.09 in non KCC holders per hectare. Net income was more in KCC holders compared to non KCC holders It was Rs.52028.23 in KCC holders and Rs.42741.66 in non KCC holders per hectare. Overall Gross income of wheat crop per hectare was more in KCC holders. It was Rs.82920.79 in KCC holders and Rs.77409.10 in non KCC holders per hectare. Net income was more in KCC holders compared to non KCC holders. It was Rs.29070.58 in KCC holders and Rs.25688.13 in non KCC holders per hectare.

### CONCLUSION

Total cost per hectare was higher in KCC farmers compared to non- KCC farmers. This difference was mainly due to higher cost of variable input used in KCC farmers compared to non- KCC farmers. The cost of cultivation shown increasing trend from marginal to large farmer

in KCC holders and non KCC holders. It due to fact that large size of holding farmer could incur more expenditure on modern farm input like quality of seed, hired labour, manure, fertilizers, plant protection and machine labour charges etc. Cost  $A_1$  and cost  $A_2$  were found to be same as there was no land was taken on lease. Cost  $B_1$ , cost  $B_2$ , cost  $C_1$  and  $C_2$  was more of KCC farmers than the non KCC farmers. It was found the impact of the KCC scheme on production, productivity and income increased under all the categories after availing credit under KCC scheme. Among the different categories of farmers, productivity of marginal, medium, and large KCC holders has been recorded higher compared to non-KCC holders. Production of sugarcane, paddy and wheat crop on KCC holders' farms was also found to be higher compared to non-KCC holders. The productivity per hectare was increased on their farms due to use of credit amount availed under the KCC scheme for purchasing the best quality inputs. At the overall, gross returns, net returns of sugarcane, paddy and wheat crops was higher in KCC holders compared to non-KCC holders.

### REFERENCES

1. Bhangale, A. I. and Sarode, A. P. (2015). Impact of the Kisan Credit Card scheme on the farmers in Jalgaon district with particular reference to banana cultivation. *Indian Streams Research Journal*, **5**(7): 1-10.
2. Olekar, (2012). Effectiveness of Kisan Credit Card scheme in Karnataka state. *International Journal of Research in Commerce, IT and Management*, **2** (7):104-109.
3. Patra, S. and Sahu, K. K. (2011). An econometric study of determinants of credit under Kisan Credit Card. *International Journal of Arts and Commerce*, **1**(2):100-113.
4. Patel, S. S. (2012). Performance of Kisan Credit Card scheme in Mahasamund district of Chhattisgarh: An economic evaluation, M.Sc. (Agri.) Thesis, Indira Gandhi Krishi Vidyalaya, Raipur, India.
5. Prakash, P. (2013). Impact of Kisan Credit Card on farm economy: A case study of Krishnagiri district of Tamil Nadu. M.Sc. (Agri.) Thesis, Indian Agricultural Research Institute, New Delhi.
6. Sajane, A. M., Basavaraja, H., Guledgudda, S. S., Patil, B. L., Mahajanshetty, S. B. and Bhat, A. R. (2011). Economic evaluation of Kisan Credit Card. *Karnataka Journal of Agricultural Sciences*, **24**(2): 173-176.
7. Sajane, A.M., Shinde, V.A., Sale, Y.C. and Satpute, S.V. (2011). Economic Impact on Kisan Credit Card Scheme on Profitability of Crops. *International Research Journal of Agricultural Economics and Statistics*, **2**(2): 324-327.

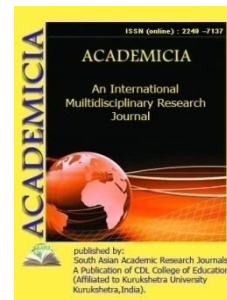
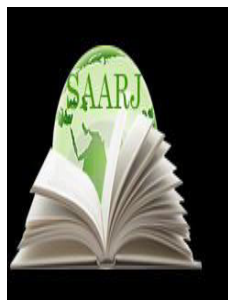

DOI: **10.5958/2249-7137.2021.01959.5**

## OPTIMIZATION OF THE ACID ACTIVATION PROCESS OF BENTONITE

Jobir X. Xamroyev\*; Normurot I. Fayzullayev\*\*; Jasur H. Shukurov\*\*\*;  
Rustam D. Berdiyev\*\*\*

\*Samarkand Medical Institute,  
UZBEKISTAN

\*\*Samarkand State University,  
UZBEKISTAN

\*\*\*Academic Lyceum of Samarkand State University,  
UZBEKISTAN

Email id: fayzullayev72@inbox.ru

### ABSTRACT

*The fields of application of Bentonite clays are expanding due to imparting new properties to them as a result of various types of activation. One of the most effective treatments is acid treatment. Acid-activated montmorillonites are used as acid catalysts for various reactions. Acid activation with HCl solution of calcium and sodium montmorillonites of the Navbakhor deposit was carried out. It was shown that, as a result of acid treatment, the development of a porous structure occurs due to the removal of both interlayer cations ( $\text{Na}^+$ ,  $\text{Ca}^{2+}$ ) and cations of the octahedral layer ( $\text{Al}^{3+}$ ,  $\text{Fe}^{2+}$ ,  $\text{Mg}^{3+}$ ). The textural characteristics and strength properties of moulded composites based on acid-activated montmorillonites have been investigated. The purpose of this study is to identify the optimal conditions for acid activation and to study the textural characteristics of bentonite from the Navbakhor deposit.*

**KEYWORDS:** Bentonite, Activation, Processing, Modification, Optimization, Texture Characteristics.

### INTRODUCTION

Bentonite clays are good inexpensive sorbents for various substances, such as heavy metal ions [1], organic dyes [2]. Sorption occurs due to the presence of layered silicates (phyllosilicates, smectites) in the composition of clays, such as 2 montmorillonite, palygorskite, illite. Acid

activation of bentonite clay is a widespread method of obtaining porous sorbents for organic and inorganic substances [5, 6], acid catalysts [4, 7].

In addition, acid activation with preservation of the layered structure is necessary as an initial stage in the chemical modification of phyllosilicates [8]. It should be noted that activation must be cost-effective. Preference is given to, if possible, dilute solutions of acids, relatively low temperatures and activation times. It should also be taken into account that washing clay from excess acid is a rather laborious process, therefore, in most cases, it is advisable to calculate in advance the optimal acid concentration, taking into account the peculiarities of the chemical composition of natural clay, the presence of impurities. The study of the physicochemical parameters of clays of various deposits, activated by various acids, is devoted to a sufficient number of works [9–14].

Much attention in the literature is paid to natural framework aluminosilicates, especially zeolites. These materials have a negatively charged three-dimensional aluminosilicate framework. In the gaps of the framework, there are hydrated positive ions of alkali metals, which compensate for the charge of the framework, and water molecules. When zeolites are heated, water is released from them, and adsorption cavities are formed. The areas of application of bentonite clays will expand by imparting new properties to them as a result of various types of activation [7–11]. One of the most effective types of exposure is acid treatment [5, 10–12].

According to the nature and strength of the effect on the crystal structure of montmorillonites, acids can be divided into three groups [13–18].

The first group consists of organic and dilute mineral acids, which extract only exchangeable cations from the lattice of montmorillonite into solution and do not affect aluminosilicate layers and the order of their packing. At the same time, the porous structure remains practically unchanged: the specific surface is 60–70 m<sup>2</sup>/g, the limiting specific volume of the sorption space is about 0.13 cm<sup>3</sup>/g. The second group - solutions of mineral acids of medium concentrations (2–4 N). Under the influence of these acids, exchangeable (Na<sup>+</sup>, Ca<sup>2+</sup>) and octahedral cations (Al<sup>3+</sup>, Fe<sup>3+</sup>, Mg<sup>2+</sup>) are extracted into the solution, once the aluminosilicate packets are ordered in the basal direction, but the structure of the aluminosilicate layers is not disturbed.

As a result, the pore space of montmorillonites develops significantly, S<sub>sp</sub> increases to 330 m<sup>2</sup>/g, V<sub>pore</sub> to 0.5 cm<sup>3</sup>/g. Concentrated mineral acids (more than 4 N) belong to the third group, which destroy the crystal structure of montmorillonite, wash out all cations, except for silicon, resulting in the formation of highly porous silicon oxide [14].

Acid-activated montmorillonites are widely used as acid catalysts for such reactions as cracking, isomerization, alkylation, acetylation, dimerization and polymerization of unsaturated hydrocarbons, hydrogenation and dehydrogenation of hydrocarbons, dehydration of alcohols, hydration of olefins, hydrotreating, formation of esters, etc. [7, 15–19].

In addition, recently all over the world, there has been an increase in interest in the use of natural minerals and composites based on them as carriers for catalysts and desiccants, which can compete with traditional SiO<sub>2</sub>, Al<sub>2</sub>O<sub>3</sub>, zeolites both at the expense of a lower price and due to higher operational characteristics of the material.



The proposed classifications of porous bodies are based mainly on experimental data on the size of pores or their fractional composition. They do not reflect the origin and structure of porous bodies [20-21]. M.M. Dubinin is known to divide the pores as follows (by the effective radius):

- - macropores with  $r_{eff} > 100$  nm;
- - mesopores with  $1.5 < r_{eff} < 100$  nm;
- micropores with  $r_{eff} < 1.5$  nm.

Of particular interest is the characteristic of the microporous structure of adsorbents in the case of an activated nature of adsorption [22-25]. It should be recalled that according to the classification of M.M. Dubinin, the effective radius of micropores is in the range of  $r \leq 1.6 \dots 1.8$  nm. In a number of works, formations with  $r < 0.6 \dots 0.7$  nm are attributed to micropores [25-26]. Larger micropores, the so-called. super micropores are represented by the transition region between the micro-and mesopores proper [24].

## EXPERIMENTAL PART

The enriched fraction of Navbakhor bentonite was used for the work, which was obtained as follows: a suspension of 30 g of native clay in 300 ml of distilled water was prepared with thorough stirring; the particles of all the minerals that make up the clay were divided into fractions. The resulting suspension was left for a day. Then, the enriched clay fraction was separated by centrifugation at 8000 rpm for 5 min. The resulting fraction was dried in air for 12 hours, then at a temperature of 65 °C for 12 hours. Activation was carried out with hydrochloric acid of concentration 0.5 M and 2.0 M at a temperature of 88 °C for two hours. After activation, the clay suspension was not slowly cooled by pouring it into 200 ml of distilled water. Then the clay was washed several times with distilled water, centrifuged and dried for 12 hours at room temperature, then for 12 hours at 65 °C, ground in a mortar and stored in polyethylene containers. Mechanical activation of bentonites in the process of grinding makes it possible to achieve an increase in the total activity of particles by reducing their size, increasing the total surface, achieving a more compact form of particles, and profound transformations in the crystal structure of the material. To study the activation parameters of clays, an AGO-2 planetary-centrifugal mill-activator with varying activation time from 10 to 180 seconds was used in order to achieve the maximum degree of grinding of bentonite clays with their maximum activity while maintaining the characteristics of the crystal-chemical structure and the absence of aggregation.

Mechanical activation (MA) in the AGO-2 planetary-centrifugal mill was carried out at a ratio of the mass of clay and grinding bodies 1: 2 (for bentonite clays –30–180 seconds), at a constant speed  $v_{ob} = 1500$  rpm. During the activation of clays, their quality was assessed by geometric parameters and technological properties. The technological properties of the clays were evaluated according to various indicators according to GOST. The physicochemical properties of clays as binders are largely determined by the peculiarities of their interaction with water; therefore, the influence of the activation time on the swelling, colloidal and water absorption of clays was investigated. The textural characteristics of the synthesized samples were calculated on the basis of nitrogen adsorption and desorption isotherms at 77 K, obtained on a Nova 1200 e Quantachrome volumetric apparatus. The specific surface area ( $S_{sp}$ ) of the samples was calculated by the BET method, the volume and surface of micropores ( $V_{mi}$ ,  $S_{mi}$ ) - by the t-method according to the adsorption curve, the average mesopore diameter ( $D_{me}$ ) - by the

Barrett-Joyner- Halenda method according to the desorption curve, the average micropore diameter was determined by the equation:  $D_{mi} = 2V_{mi} / S_{ud}$ . Before measuring the adsorption isotherms, the samples were degassed at 300 °C and a residual pressure of 10<sup>-3</sup> mm Hg. Art. within 4 hours. The content of zirconium and zinc in the modified bentonite was determined by laser mass spectrometry using an EMAL-2 device. The chemical composition of the samples was determined by the X-ray fluorescence method using VRA-30 (Carl Zeiss, Germany) and Optima X (MRU, Germany) instruments. To determine the average particle size, sieve analysis was performed using a set of sieves (µm): 0.071, 0.100, 0.160, 0.200, 0.250, 0.315. Fractionation was carried out on an Analysette 3 Spartan Fritsch vibrating scatter (Germany) for 15 min. The masses of the fractions retained on the sieves were determined on a technical balance Gosmetr VLTE- 1100 (Russia). The average grain size on the sieve and the average particle size= in the crushed material were calculated according to the method described in [22]. X-ray diffraction patterns of substances were taken on an X-ray diffractometer Bruker D8 ADVANCE (Germany) in CuK α -radiation; The 6 obtained X-ray diffraction patterns were identified using the VA program with a PDF-2 powder data bank. To quantitatively determine the elemental composition of the samples, we used the energy dispersive X-ray fluorescence method using a Shimadzu EDX 800 HS spectrometer (Japan). The analysis was carried out without taking into account light elements. The concentration of the determined elements was calculated by the method of fundamental parameters using the software of the spectrometer. The relative determination error did not exceed ± 2%. IR absorption spectra of phosphorus-containing samples were recorded in the range 400–4000 cm<sup>-1</sup> in vaseline oil using a Shimadzu FTIR Prestige-21 Fourier spectrometer (Japan) at room temperature. The specific surface area of the samples was determined by the method of low-temperature nitrogen adsorption using a Sorbtometer-M device (Russia).

## RESULTS AND DISCUSSION

To determine the optimal conditions for acid treatment, the method of planning extreme experiments was used [11]. As a design, a full factorial experiment was chosen, in which all possible combinations of factors are implemented at all levels selected for the study. The following factors were chosen: C – acid concentration, T - activation temperature and t - time of the clay activation process. As a response function, we used the specific surface area and the average pore radius of the clay. If the specific surface area is used as a response function, then the following regression equation can be obtained:

Equation (1) satisfies the Fisher criterion and therefore is adequate, at least in the range of variation of the parameters. Table 2 shows the values of the factors in a full factorial experiment for clays I-IV of domestic deposits. The results on the reproducibility of some characteristics of the porosity of clay I of the Navbakhor deposit treated at CHCl = 10 N, T = 80 °C, t = 2 h (plan centre conditions) are given in Table 3. In the figure, and for clay I, the response surface is shown for two values of the time t (1 h - the lower surface, 3 hours – 7 the upper surface). The figure shows that the response surface is complex. Thus, at low acid concentrations, the specific surface area increases with decreasing process temperature, while at high acid concentrations, on the contrary, surface growth is observed with increasing temperature. As for the time of acid treatment, an increase in its duration significantly affects the size of the surface.

**TABLE1. VALUES OF FACTORS IN A FULL FACTORIAL EXPERIMENT FOR CLAYS I-IV OF VARIOUS DEPOSITS**

Experiment number	Values of factors for different clay samples								
	Concentration HCl,N			T, °C			t, ч		
	IиII	III	IV	IиII	III	IV	IиII	III	IV
1	6	3	4	70	40	90	1	2	6
2	10	7	7	70	40	90	1	2	6
3	6	3	3*	90	80	90	1	2	6
4	10	7	4**	90	80	90	1	2	6
5	6	3	4***	70	40	90	3	4	6
6	10	7		70	40	-	3	4	-
7	6	3		90	80	-	3	4	-
8	10	7		90	80	-	3	4	-

\*Used nitric acid HNO<sub>3</sub>;

\*\*clay treated in hydrochloric acid was subjected to ion exchange with Al<sup>3+</sup>;

\*\*\*hydrochloric acid after experiment No.1.Reused.

**TABLE2.SOME CHARACTERISTICS OF THE POROSITY OF CLAYI**

Sample no.	S <sub>уд.</sub> , m <sup>2</sup> /g	V <sub>ер.пор.</sub> , cm <sup>3</sup> /g	D <sub>ер.пор.</sub> , Å	S <sub>пор.</sub> , m <sup>2</sup> /g	V <sub>micropores</sub> , cm <sup>3</sup> /g
0	75	0,205	146	56	0,00596
1	93	0,231	140	66	0,0058
2	92	0,216	142	60	0,0082
3	103	0,221	129,7	68,3	0,0084
4	103	0,226	125	72,3	0,0067
5	124	0,23	111	83	0,0076
6	96	0,23	133	68,9	0,0059
7	115	0,237	113	83,8	0,006
8	105	0,228	114,7	79	0,006
9	99	0,21	126,8	66	0,0084
10	103	0,217	126,4	68,6	0,0084
11	104	0,227	125	72	0,0067

\*0-original clay sample before acid treatment;1-8- samples processed under the conditions given in the table.2;

9, 10 and 11 are samples (reproducibility study), treated under the conditions of the centre of the plan (10 NHCl, 80° C, 2h).

Only at a low acid concentration, and with an increase in concentration, the influence of the time factor decreases. The extrapolation of the response surface beyond the variation intervals, most likely, does not make much physical sense, . since the resulting surface is not essentially linear and a different compositional design should be used to find the extremum, namely, the second order. However, the second-order design for three factors assumes 27 experiments and does not guarantee that the extremum will be found, since with an increase in the number of experiments, the likelihood that the resulting regression equation will be adequate decreases. This is one of the reasons why it is legitimate to stop at linear designs of a full factorial experiment.

Additional experiments in the range of values of factors corresponding to the maximum value of the surface ( $\text{CHCl} = 2 \text{ N}$ ,  $T = 40 \text{ }^\circ\text{C}$ ,  $t = 4 \text{ h}$ ) actually made it possible to obtain a surface of less than  $100 \text{ m}^2 / \text{g}$ . Thus, it can be assumed that the extremum is in the range of concentration values from 4 to 6 N, temperature from 70 to 90  $^\circ\text{C}$ , and time from 4 to 10 hours. For clay II in the table. 4 shows the values of specific surfaces and average pore diameter, as well as several other porosity characteristics. From table. 4 it follows that the toughening of acid treatment, i.e. an increase in acid concentration, an increase in the temperature and duration of the processing, and, entails an increase in the volume of pores, their average diameter and leads to a decrease in the contribution to the total surface of micropores and pores of large diameter. In this case, the average pore diameter naturally decreases. Results of a planned experiment on acidizing clays of the Navbakhor deposit. X-ray phase analysis of bentonite clays of the Navbakhor deposit (clay III) showed that the mineralogical composition of clays is distinguished by the content of a large amount of montmorillonite.

Therefore, the limiting values of the factors in the full factorial experiment were slightly changed. The changes consisted in softening the acidizing conditions, i. E. in decreasing acid concentration and processing temperature (Table 2). For clay III, the main characteristics of porosity are given in the table. 4. For verification, an extreme experiment was set up at a point with the following values of the factors:  $\text{CHCl} = 10 \text{ N}$ ,  $T = 90 \text{ }^\circ\text{C}$ ,  $t = 10 \text{ h}$ , As a result, the 9 characteristics of the porous structure of clay were obtained, shown in Table 4. Comparison of the data of sample 9 with the data of samples 4,7,8 for clay III shows that the toughening of the acid treatment conditions does not at all lead to an increase in the specific surface area, but, on the contrary, leads to its decrease (up to  $105 \text{ m}^2 / \text{g}$ ) in comparison with milder conditions. processing. Based on the totality of the data obtained, the optimal conditions for acid treatment for bentonite clay IV (Navbakhor deposit) were selected, shown in Table 2. For clay IV, in addition to variations in acid concentration, the effect of acid type was also investigated. Nitric acid was used instead of hydrochloric acid, and it was also investigated how the use of spent acid affects porosity. Chemical analysis of the spent acid showed that as a result of acid treatment with nitric acid, iron and aluminium ions are washed out of the clay. The results of studying the porous structure of clay IV are presented in Table 5.

**TABLE-3. SOME CHARACTERISTICS OF THE POROSITY OF CLAYS II AND III**

Sample no.	$S_{\text{ud}}, \text{m}^2/\text{g}$ (byBET)		$V_{\text{er.pore}}, \text{cm}^3/\text{g}$		$D_{\text{ep.пор}}, \text{Å}$		$S_{\text{por}}, \text{m}^2/\text{g}$		$V_{\text{micropores}}, \text{cm}^3/\text{g}$	
	II	III	II	III	II	III	II	III	II	III
0	70	61	0,177	0,096	151	125	46,7	31	0,006	0,087
1	96	78	0,172	0,101	115,7	102	59,6	39	0,008 9	0,011
2	98	76	0,166	0,095	113	103	58,7	37	0,009	0,012
3	112	109	0,179	0,119	102	78	70,5	61	0,008 8	0,01
4	119	124	0,192	0,153	94	67	81,7	91	0,007	0,003
5	112	66	0,19	0,093	106	111	72	34	0,008 7	0,0096
6	111	68	0,199	0,096	107,6	120	74	32	0,007	0,0094

									7	
7	136	136	0,224	0,182	92,5	68,7	97	106	0,006	0,004
8	138	146	0,246	0,208	86,3	68	114	122	0,005 7	0,003
9	-	105	-	0,226	-	99	-	92	-	0,0048

\*0- original clay sample before acid treatment; 1-8-samples processed under the conditions given in the table.2; 9-sample (reproducibility test) treated under conditions: 10NHCl, 90°C, 10h.

**TABLE-4. POROUS CHARACTERISTICS OF CLAY IV**

Sample no.	$S_{ud}, m^2/g$ (byBET)	$V_{er.pore}, cm^3/g$	$D_{ep.por}, \text{Å}$	$S_{por}, m^2/g$	$V_{micropores}, cm^3/g$
0	124	0,164	99	66	0,0146
1	300	0,511	75	272	0,0068
2	266	0,574	90	254	0,004
3	285	0,480	77	268	0,0052
4	290	0,510	76	270	0,0060
5	290	0,512	76	271	0,0061

\*0- original clay sample IV, 1-5-samples processed under the conditions given in Table 2.

In this case, the use of nitric acid (sample 3) and there use of hydrochloric acid (sample 5), as well as treatment with hydrochloric acid followed by ion exchange with  $Al^{+3}$  (sample 4), to deeply purify the solution from impurities by removing the ion-exchange products reactions from the reaction sphere resulted in practically the same properties of the porous structure as for sample 1. A significant decrease in the specific surface area (sample 2) should be noted with an increase in the acid concentration from 4 to 7 N.

**TABLE-5. OPTIMUM CONDITIONS FOR ACIDIZING CLAYS I AND IV**

Clay number	$S_{ud}, m^2/g$ (byBET)	$C_{HCl}, N$	$T, ^\circ C$	$t, h$
I	105	4-6	70-90	4-10
II	137	10	90	3
III	266	10	90	10
IV	308	4	90	6

## CONCLUSION

Thus, the dependence of the specific surface area of clay on the parameters of acidizing is non-linear. The optimal results of acid treatment are shown in the table. 5. Analysis of the tabular data shows that for all clay samples, the optimal porosity values are achieved at  $CHCl = 6-10 N$ ,  $T = 90 ^\circ C$ ,  $t = 6-10 h$ . The use of waste hydrochloric and nitric acids instead of hydrochloric acid for the treatment of clays practically does not affect their porous characteristics.

## REFERENCES

1. Ibodullayevich, F. N., Yunusovna, B. S., & Anvarovna, X. D. (2020). Physico-chemical and texture characteristics of Zn-Zr/VKTS catalyst. Journal of Critical Reviews, 7(7), 917-920.

2. Omanov, B. S., Xatamova, M. S., Fayzullaev, N. I., Musulmonov, N. K., & Asrorov, D. A. (2020). Optimization of vinyl acetate synthesis process. *International Journal of Control and Automation*, 13(1), 231-238.
3. Omanov, B. S., Fayzullaev, N.I., & Xatamova, M.S. (2020). Vinyl Acetate Production Technology. *International Journal of Advanced Science and Technology*, 29 (3), 4923-4930.
4. Mamadoliev, I.I., & Fayzullaev, N.I. (2020). Optimization of the activation conditions of high silicon zeolite. *International Journal of Advanced Science and Technology*, 29 (03), 6807-6813.
5. Rakhmatov, S. B., & Fayzullayev, N. I. (2020). Coke Formation of Catalyst on the Ethylene Preparation from the Ox condensation of Methane and its Regeneration. *International Journal of Advanced Science and Technology*, 29 (03), 7875-7884.
6. N. S. Sarimsakova., N. I. Fayzullaev., N. X. Musulmonov., S. T. Atamirzayeva., M. N. Ibodullayeva. Kinetics and Mechanism of Reaction for Producing Ethyl Acetate from Acetic Acid// *International Journal of Control and Automation* Vol.13, No.2, (2020), pp.373–382
7. Tursunova, N. S., & Fayzullaev, N. I. (2020). Kinetics of the Reaction of Oxidative Dimerization of Methane. *International Journal of Control and Automation*, 13 (2) ,440-446.
8. Mamadoliev, I.I., Khalikov, K.M., & Fayzullaev, N.I. (2020). Synthesis of high silicon of zeolites and their sorption properties. *International Journal of Control and Automation*, 13 (2), 703-709.
9. Fayzullaev, N. I., Bobomurodova, S. Y., Avalboev, G. A., Matchanova, M. B., & Norqulova, Z. T. (2020). Catalytic Change of C1-C4-Alkanes. *International Journal of Control and Automation*, 13 (2), 827-835.
10. Bobomurodova, S.Y., Fayzullaev, N.I., & Usmanova, K.A. (2020). Catalytic aromatization of oil satellite gases. *International Journal of Advanced Science and Technology*, 29 (5), 3031-3039.
11. Fayzullaev, N.I., Karjavov, A.R., & Yusupova, S.S. (2020). Catalytic Synthesis of Acetone Direct Acetylene Hydration. *International Journal of Advanced Science and Technology*, 29 (05), 4507-4514.
12. N. I. Fayzullaev., T. B. Shoymardanov., D. R. Hamidov., 3B. Sh. Omanov. Synthesis Gas by Conversion of Methane with Carbonate 12 Anhydride// *International Journal of Advanced Science and Technology* Vol. 29, No. 5, (2020), pp. 5991 – 6000
13. N. I. Fayzullaev., D. R. Hamidov., 2N. R. Ortiqov., Yu. Kh. Khidirova, T. B. Shoymardanov., Kh. B. Rakhmatov. Kinetic Laws of Methane Catalytic Oxychlorination Reaction// *International Journal of Advanced Science and Technology* Vol. 29, No. 5, (2020), pp. 6001 – 6009
14. Akbarov Kh.I., Eshmamatova N.B., Fayzullaev N.I., Kalyadin V.G., Azimov L.A. Synthesis and Physico-Chemical Properties of Oligomeric Inhibitors of Corrosion on the Base of Nitrogen, Phosphorous-Containing Compounds// *International Journal of Advanced Science and Technology* Vol. 29, No. 5, (2020), pp. 6489 – 6506



15. N.I.Fayzullaev., N.S.Tursunova. Thermodynamic Basis of Methane Oxidation Dimerization Reaction and Process Approval// International Journal of Advanced Science and Technology Vol. 29, No. 5, (2020), pp. 6522 – 6531
16. N.I.Fayzullaev., S.Yu. Bobomurodova., F.S. Karimova., A.Yu.Buronov. Catalytic Aromatization of Propane-Butane Fraction// International Journal of Advanced Science and Technology Vol. 29, No. 5, (2020), pp. 6532 –6540
17. A.R. Karjavov., N.I. Fayzullayev., N.X. Musulmonov. Jointly Catalytic Synthesis of Vinyl Chloride and Chloroprene from Acetylene// International Journal of Control and Automation Vol. 13, No. 4, (2020), pp. 55 – 62
18. N.I.Fayzullaev., D.R.Hamidov., Z.T. Ruziyevna., Yu.Kh. Khidirova., T.B.Shoymardanov., B.Sh. Omanov. Kinetic Laws of Catalytic Pyrolyze of Methylchloride// International Journal of Control and Automation Vol. 13, No. 4, (2020), pp.211 – 219
19. Umirov F.E., Fayzullaev N.I., Usanbayev N.Kh., Umirov U.F., Muzaffarov A.M., Pirnazarov F.G. Mineralogical and Technological Evaluation of Saponites of the Uchtut Residential Place in the Republic of Uzbekistan// International Journal of Control and Automation Vol. 13, No. 4, (2020), pp.230 – 236
20. N.I.Fayzullayev., T.B.Shoymardanov., D.M. Begimqulova., D.R.Hamidov., Kh.B. Rakhmatov. Kinetic Laws of Methane Carbonate Conversion 13 Reaction// International Journal of Control and Automation Vol. 13, No. 4, (2020), pp. 268 – 276
21. N.I. Fayzullaev., S.Yu. Bobomurodova., L.M. Kurbanova., A.Yu. Buronov.The Physicochemical and Textural Characteristics of Catalysts in the Catalytic Aromatization Reaction of Propane- Butane Fractions// International Journal of Control and Automation Vol. 13, No. 4, (2020), pp. 888 – 896
22. J.K. Mamatov., A.Yu. Yarkulov., F.G. Rakhmatkariyeva., N.I.Fayzullayev., Kh.I. Akbarov. Physical and Chemical Properties of Hybrid Polyacrylonitril- Silica Nanocomposites// International Journal of Control and Automation Vol. 13, No. 4, (2020), pp.220 – 229
23. Omanov, B. S., Fayzullayev, N. I., & Xatamova, M. S. (2020). Catalytic synthesis of acetylene ut of vynil acetate and texture characteristics of catalysts. Asian Journal of Multidimensional Research (AJMR). Special Issue, March, 157-164.
24. Оманов,Б.Ш.,Хатамова,М.С.,&Файзуллаев,Н.И.(2020).Технологиипроизводственныев инилацетат.*Инновационнаянаука*,(3),10-12.
25. Оманов,Б.Ш.У.,&Файзуллаев,Н.И.(2020).Параметрытехнологическогогорезимасинтезав инилацетата.*Universum:химияибиология*,(4(70)).

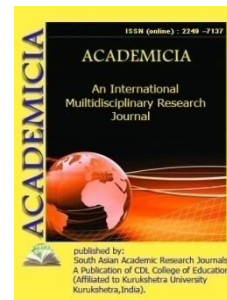
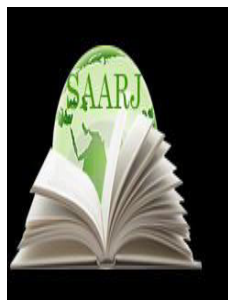

DOI: **10.5958/2249-7137.2021.01960.1**

## CHARACTERISTICS OF THE $\text{Fe}_2(\text{MoO}_4)_3 \cdot \text{MoO}_3$ CATALYST USED IN THE SYNTHESIS OF NANOCARBONS FROM METHANE

**Hilola N. Xolmirzayeva\***

Laboratory Assistant,  
Department of Analytical Chemistry,  
Samarkand State University, Samarkand,  
UZBEKISTAN  
Email id: hilola.xolmirzaeva@mail.ru

### ABSTRACT

*The analysis of the physicochemical and operational characteristics of two industrial catalysts for the synthesis of nanocarbon is carried out. Various methods: X-ray phase, chemical, IR spectroscopy investigated the composition of the catalysts. It was shown that the main component of industrial catalysts is iron molybdate (67.27%). The catalyst contains about 31%  $\text{MoO}_3$ , and 1-2% of molybdenum oxide is included in the lattice of iron molybdate, forming a solid solution. The presence of acid sites of the type on the surface of the catalysts was detected by IR spectroscopy. Lewis and Bronsted and the main centres of varying strength. The catalysts are highly active: their formaldehyde productivity reaches a value (12.5-13 mmol/g.s). The surface area of industrial contacts is (7-9  $\text{m}^2/\text{g}$ ); the size of the mesopores is 2-40 nm. Thus, industrial catalysts for the synthesis of nanocarbon are of high quality, which ensures their high performance throughout the entire period of operation.*

**KEYWORDS:** Iron Molybdate, Molybdenum, Catalyst, IR Spectroscopy, Radiograph

### INTRODUCTION

Iron molybdate  $\text{Fe}_2(\text{MoO}_4)_3$  has a monoclinic structure, in which  $\text{Fe}^{3+}$  cations occupy slightly distorted octahedral positions, while  $\text{Mo}^{6+}$  ions have tetrahedral coordination. Both types of ions are linked by an oxygen bridge. The fraction of molybdenum in the form of free  $\text{MoO}_3$  in both industrial Fe - Mo catalysts is about 21% atm in terms of Mo. This is established using X-ray fluorescence analysis. And only a small number of molybdenum atoms (1-2%) are incorporated into the crystal lattice of the  $\text{Fe}_2(\text{MoO}_4)_3$  phase, where there is a significant amount of free tetrahedral vacancies because only 3 out of 24 available ones are filled. The presence of a

significant amount of the free  $\text{MoO}_3$  phase is confirmed by the X-ray phase analysis data, where the diffractograms contain intense reflections of the  $\text{MoO}_3$  phase (Figure 1).

The IR spectra of the studied catalytic systems do not differ significantly, as do the X-ray diffraction patterns for both catalysts. They contain characteristic absorption bands of Mo-O bonds in various compounds. A weak band at  $991\text{ cm}^{-1}$  and broadband at  $624\text{ cm}^{-1}$  characterize the free  $\text{MoO}_3$  phase. The weak and narrowband at  $960\text{ cm}^{-1}$  can be associated with vibrations of the Fe-O-Mo bond. Several broad bands in the range  $700\text{--}900\text{ cm}^{-1}$  can be attributed to tetrahedral Mo species in  $\text{Fe}_2(\text{MoO}_4)_3$  (Fig. 1). The nature of the surface sites of iron-molybdenum oxide catalysts has been studied in several studies [70].

## MATERIALS AND METHODS

These works showed the existence of acid sites and their significant role in the oxidation of methane. However, the results obtained do not allow distinguishing these centres according to type and strength. The performed pK-spectroscopic studies have shown the presence on the surface of the studied samples not only of acidic centres of the Lewis and Bronsted type but also of basic centres.

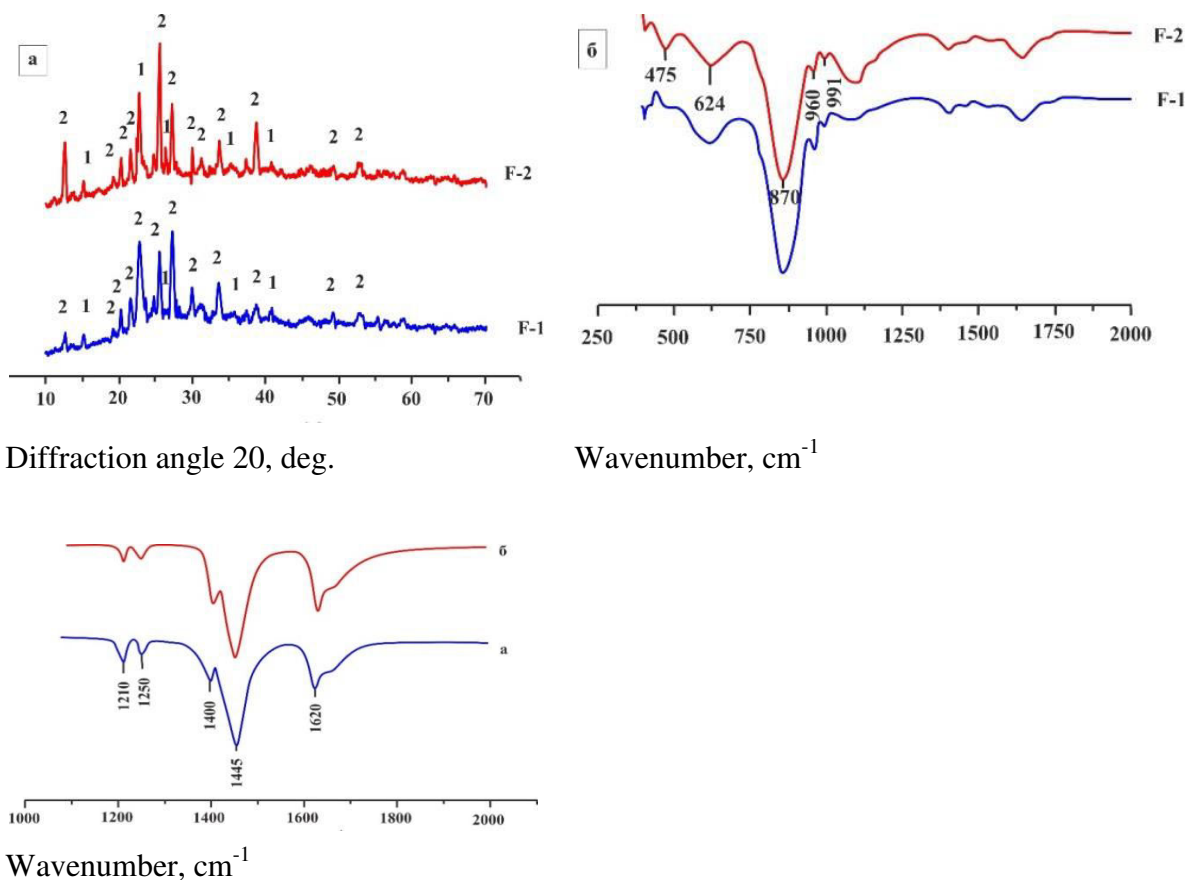

Figure 1.  $\text{Fe}_2(\text{MoO}_4)_3$  (a) and  $\text{Fe}_2(\text{MoO}_4)_3 \cdot \text{MoO}_3$  (b) brand catalyst for nitrogen adsorption and IR spectra

The Lewis acid centre is surface metal cations with free bonds, and the Bronsted acid centre is the Lewis centre that has absorbed water. The main centres are oxygen anions, which are located

on the surface. The presence of Lewis centres was confirmed by absorption bands in IR spectra ( $1210$ ,  $1250$ ,  $1620$   $\text{cm}^{-1}$ ), Bronsted centres ( $1445$ ,  $1400$   $\text{cm}^{-1}$ ) characterizing coordinated ammonia (Figure 1).

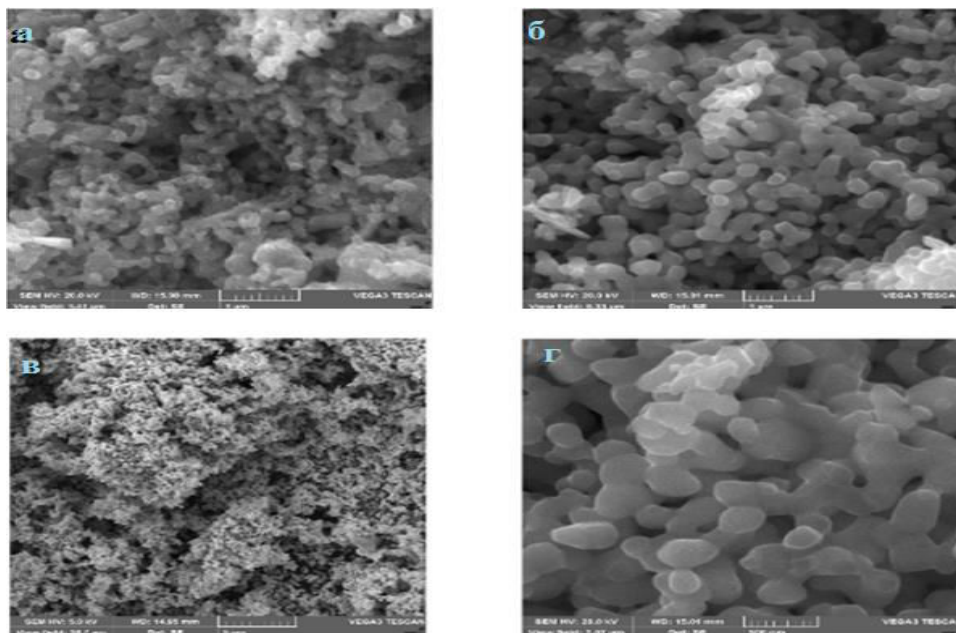

Figure 2. SEM results of catalysts

**Hydrothermal synthesis of iron molybdate.** Hydrothermal synthesis has long established itself as one of the most widespread methods for obtaining various functional nanomaterials with specified micro and nanostructures. He has demonstrated advantages in the processing of nanostructured materials for a variety of industries such as electronics, optoelectronics, catalysis, ceramics, magnetic storage, biomedicine, and biophotonics. The process of hydrothermal synthesis initiates the nucleation and growth of nanocrystals. In particular, the formation of crystalline products through a hydrothermal process can be performed at substantially lower temperatures than those required in solid-phase synthesis. Hydrothermal synthesis is regarded as one of the most promising due to such advantages as a relatively low reaction temperature and chemical homogeneity.

The method of hydrothermal synthesis makes it possible, under relatively mild conditions, to obtain nanocrystalline powders in one step with the ability to control the morphology, particle size, and phase composition of the products. Investigations of the process of hydrothermal synthesis of iron molybdate and, on its basis, a catalyst for the partial oxidation of methane to formaldehyde, we used ammonium heptamolybdate  $(\text{NH}_4)_6\text{Mo}_7\text{O}_{24}\cdot 4\text{H}_2\text{O}$  and iron nitrate  $\text{Fe}(\text{NO}_3)_3\cdot 9\text{H}_2\text{O}$ .

As the data of X-ray phase analysis show, the process of formation of a crystalline precipitate is significantly influenced not only by temperature but also by the duration of synthesis.

As a result of hydrothermal treatment (HTT) at a temperature of  $100$   $^\circ\text{C}$  for 4 hours, well-crystallized phases are formed (Figure 3). An increase in the HTT time to 8 hours leads to a strong amorphization of the product. Formation of this phase, which cannot be indexed as one of the known crystalline phases of iron molybdate (Figure 3).

It crystallizes directly from the mother liquor as an intermediate product. Hydrothermal treatment for 10 hours at a temperature of 100 °C leads to an almost complete conversion of  $\text{Fe}_2(\text{MoO}_4)_3$  into iron molybdate (Figure 3).

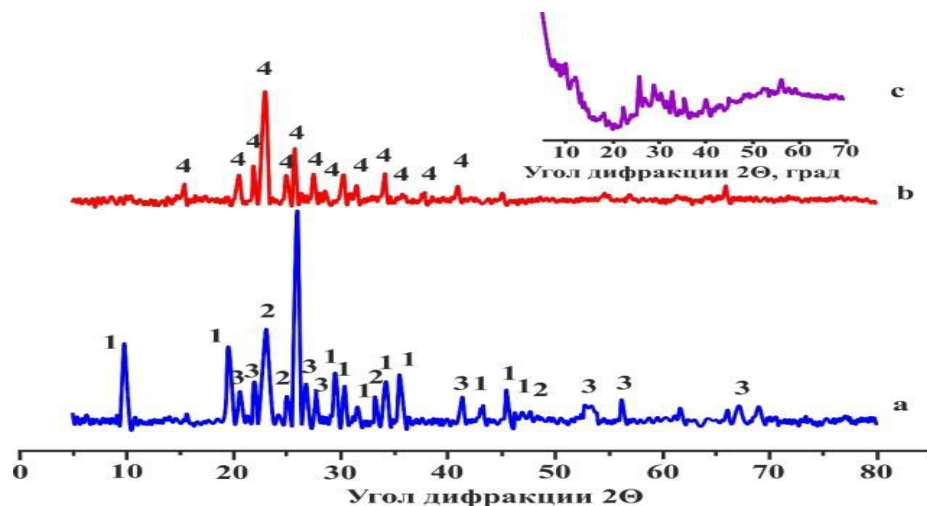

Synthesis temperature 100 °C; indexing phase: 1- $\alpha$ - $\text{MoO}_3$ ; 2-NiO; 3- $\text{Co}_2\text{O}_3$ ; 4- $\text{NiO} \cdot \text{Co}_2\text{O}_3 \cdot \text{ZrO}_2 \cdot \text{Fe}_2(\text{MoO}_4)_3$ . a-3 hours; b-10 hours; s-15 hours

Figure 3. Changes in the radiograph during the hydrothermal synthesis of iron molybdate

At ASTM International (American Society for Testing and Materials) there are numerous variations in the structures of iron molybdate. So, for example, there are two types of monoclinic crystal lattice  $\text{Fe}_2(\text{MoO}_4)_3$ , in which the position of the 100% peak differs significantly from  $2\theta = 22,99^\circ$  и  $2\theta = 27,51^\circ$ . The difference in the parameters of the crystal lattice a, b, and c is minimal and only the angle  $\beta$  differs insignificantly. Refinement of the parameters of the crystal lattice of iron molybdates obtained at different times of hydrothermal treatment indicates a rearrangement of the crystal lattice of iron molybdate. Only the lattice parameter b and the angle  $\beta$  undergo significant changes. An increase in temperature and, accordingly, pressure in the autoclave made it possible to establish that carrying out the process at a temperature of 160 °C and absolute pressure of 617 kPa for 3 hours, the interaction between the components of the mixture ends, as evidenced by the absence of free molybdenum oxide on the X-ray diffraction patterns (Figure 4).



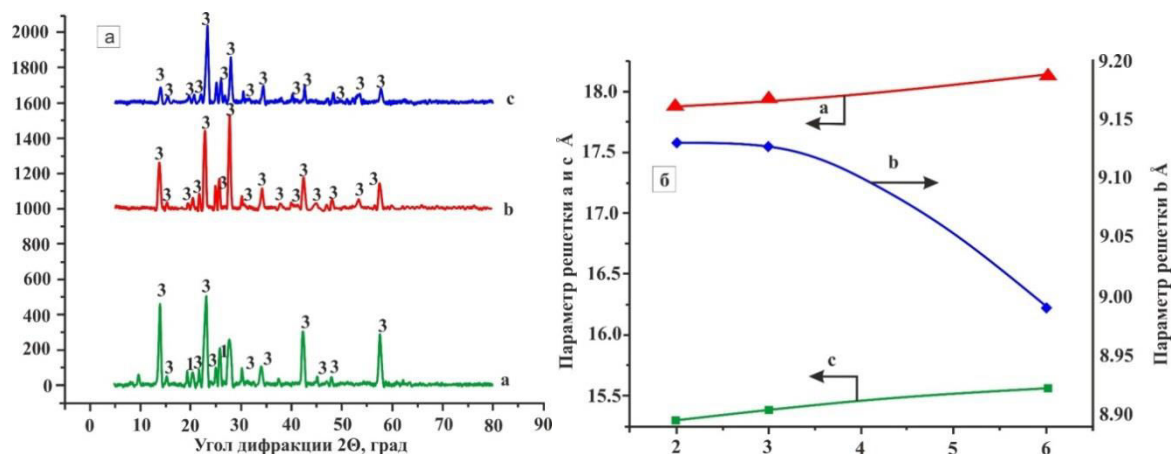

Duration of hydrothermal treatment: a-2 hours; b-4 hours; at -8 o'clock indexing phase: 1-  $\text{MoO}_3$ ; 2- $\text{Fe}_2(\text{MoO}_4)_3$ .

Figure 4. Influence of hydrothermal treatment time on the phase composition (a) and structural parameters (b) of iron molybdate at 160 °C

Analysis of X-ray diffraction patterns shows that the formation of iron molybdate at a temperature of 160 °C is completely completed within 3 hours (Figure 4). However, the position of the 100% peak is significantly shifted compared to other samples. In this case, the starting materials, oxides or hydroxides of molybdenum and iron are not detected. Modelling the structure of iron molybdate indicates the possible existence of another iron molybdate, which has a monoclinic crystal lattice, differing from analogues only by the angle  $\beta=125,46^\circ$ . Thus, the hydrothermal process makes it possible to obtain monoclinic  $\text{Fe}_2(\text{MoO}_4)_3$  micron-sized particles with a complex three-dimensional structure.

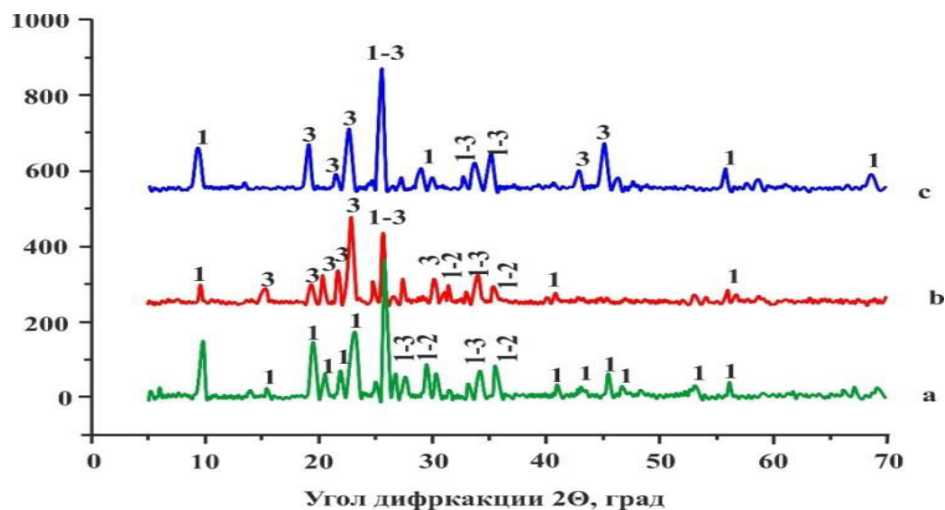

Hydrothermal treatment temperature: a-100 °C; b-150 °C; v-200 °C

Indexed phases: 1- $\text{MoO}_3$ ; 2- $\text{Fe}_2\text{O}_3$ ; 3- $\text{Fe}_2(\text{MoO}_4)_3$

Figure 5. The effect of temperature and pressure on the phase composition of iron molybdate at a duration of 3 h



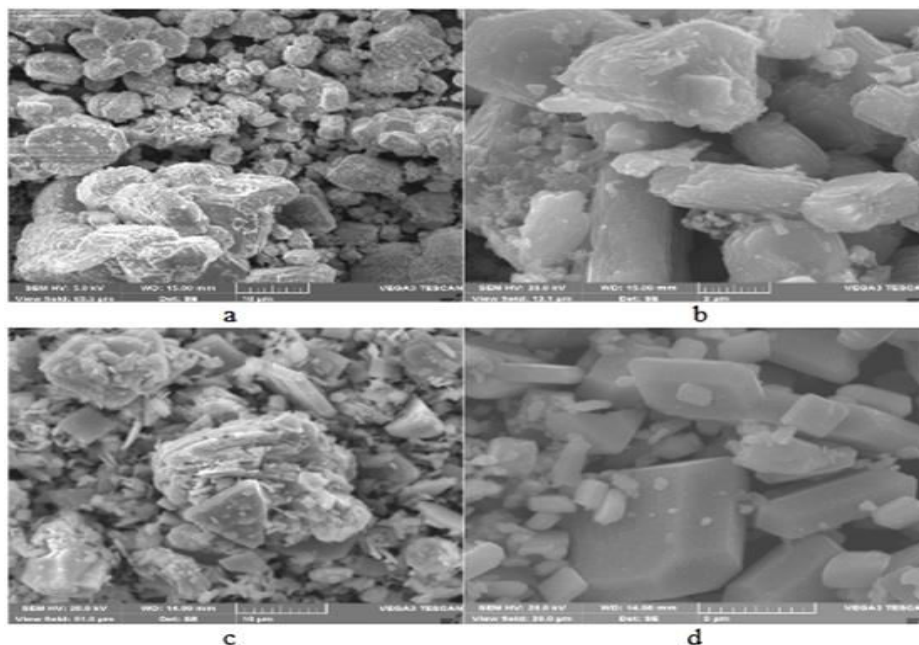

Hydrothermal treatment temperature: 120 °C

Duration of hydrothermal treatment: 4 hours; Mo: Fe atomic ratios: a-1; b-1.5; s-2.0; d-2.3;

Figure 6. Hydrothermal synthesis of iron molybdate SEM results

Analyzing the results of scanning electron microscopy, it can be seen that Mo:Fe ratio significantly changes the shape and size of the particles (Figure 6). However, samples with a Mo:Fe ratio  $<2.1$  have a densely packed layered structure with a wafer thickness of about 500 nm. Note that a sample with a Mo: Fe = 2.1 ratios is distinguished by the predominance of particles of a regular, although not symmetric, shape. The particles can be characterized as a combination of simple forms of the monoclinic system: two pinacoids and four dihedrons. An increase in Mo:Fe atomic ratio to 2.5 leads to a chaotic arrangement of crystals of irregular shape combined into an aggregate with a hollow interior. These morphological changes observed above can be attributed to the difference in the process of crystallization and crystal growth under different reaction conditions.

## CONCLUSIONS

The analysis of the physicochemical and operational characteristics of two industrial catalysts for the synthesis of nanocarbon is carried out. Various methods: X-ray phase, chemical, IR spectroscopy investigated the composition of the catalysts. It was shown that the main component of industrial catalysts is iron molybdate (67.27%). The catalyst contains about 31%  $\text{MoO}_3$ , and 1-2% of molybdenum oxide is included in the lattice of iron molybdate, forming a solid solution. The presence of acid sites of the type on the surface of the catalysts was detected by IR spectroscopy. Lewis and Bronsted and the main centres of varying strength. The catalysts are highly active: their formaldehyde productivity reaches a value (12.5-13 mmol/g.s). The surface area of industrial contacts is (7-9  $\text{m}^2/\text{g}$ ); the size of the mesopores is 2-40 nm. Thus, industrial catalysts for the synthesis of nanocarbon are of high quality, which ensures their high performance throughout the entire period of operation.

**REFERENCES**

1. Bobomurodova, S. Y., Fayzullaev, N. I., & Usmanova, K. A. (2020). Catalytic aromatization of oil satellite gases. *International Journal of Advanced Science and Technology*, 29(5), 3031-3039.
2. Tursunova, N. S., & Fayzullaev, N. I. (2020). Kinetics of the Reaction of Oxidative Dimerization of Methane. *International Journal of Control and Automation*, 13(2), 440-446.
3. Fayzullaev, N. I., Bobomurodova, S. Y., Avalboev, G. A., Matchanova, M. B., & Norqulova, Z. T. (2020). Catalytic Change of C1-C4-Alkanes. *International Journal of Control and Automation*, 13(2), 827-835.
4. Mamadoliev, I. I., Khalikov, K. M., & Fayzullaev, N. I. (2020). Synthesis of high silicon zeolites and their sorption properties. *International Journal of Control and Automation*, 13(2), 703-709.
5. Sarimsakova, N. S., Atamirzayeva, S. T., Fayzullaev, N. I., Musulmonov, N. X., & Ibodullayeva, M. N. (2020). Kinetics and mechanism of reaction for producing ethyl acetate from acetic acid. *International Journal of Control and Automation*, 13(2), 373-382.
6. Mamadoliev, I. I., & Fayzullaev, N. I. (2020). Optimization of the activation conditions of high silicon zeolite. *International Journal of Advanced Science and Technology*, 29(03), 6807-6813.
7. Omanov, B. S., Xatamova, M. S., Fayzullaev, N. I., Musulmonov, N. K., & Asrorov, D. A. (2020). Optimization of vinyl acetate synthesis process. *International Journal of Control and Automation*, 13(1), 231-238.
8. Ibodullayevich, F. N., Yunusovna, B. S., & Anvarovna, X. D. (2020). Physico-chemical and texture characteristics of Zn-Zr/VKTS catalyst. *Journal of Critical Reviews*, 7(7), 917-920.
9. Omanov, B. S., Fayzullaev, N. I., & Xatamova, M. S. (2020). Vinyl Acetate Production Technology. *International Journal of Advanced Science and Technology*, 29(3), 4923-4930.
10. Fayzullayev, N. I., & Umirzakov, R. R. (2005). To obtain acetone by spontaneous hydration of acetylene. In *ACS National Meeting Book of Abstracts* (pp. PETR-71).
11. Fayzullayev, N. I., Umirzakov, R. R., & Pardaeva, S. B. (2005). Study of acetylating reaction of acetylene by gas chromatographic method. In *ACS National Meeting Book of Abstracts* (pp. PETR-66).
12. Fayzullaev, N. I., Jumanazarov, R. B., & Turabjanov, S. M. (2015). Heterogeneous Catalytic Synthesis of Vinylchloride by Hydrochlorination of Acetylene. *IJISSET-International Journal of Innovative Science, Engineering & Technology*, 2(9).
13. Fayzullaev, N.I., Fayzullaev, O.O. Kinetic regularities in reaction of the oxidizing condensation of methane on applied oxide catalysts//*Khimicheskaya Promyshlennost'*, 2004, (4), стр. 204–207
14. Fayzullaev, N.I., Muradov, K.M. Investigation of reaction of catalytic vapor-phase synthesis of vinyl acetate on applied catalyst//*Khimicheskaya Promyshlennost'*, 2004, (3), стр. 136–139

15. Mukhamadiev, N.Q., Sayitkulov, Sh.M., Ergashev, I.M., Khafizov, Kh.F., Fayzullaev, N.I. Optimization of separation on the basis of Unifac parameters and evaluation of the composition of the stationary phase in gas-liquid chromatography//*Chromatographia*, 2003, 57(11-12), стр. 831–833
16. Muradov, K.M., Fajzullaev, N.I. Technology for producing the ethylene using the reaction of the oxidizing condensation of methane//*Khimicheskaya Promyshlennost'*, 2003, (6), стр. 3–7
17. Muradov, K.M., Fajzullaev, N.I. Optimization of process of synthesis of aromatic nitriles//*Khimicheskaya Promyshlennost'*, 2003, (4), стр. 8–11
18. Muradov, K.M., Fajzullaev, N.I. Optimization of process of synthesis of aliphatic nitriles//*Khimicheskaya Promyshlennost'*, 2003, (3), стр. 3–10
19. Fayzullaev, N. I., Yusupov, D., Shirinov, X. S., Korotoev, A. V., & Umirzakov, R. R. (2002). Catalytic vaporphase hydration of acetylene and its derivatives. *Chemical Industry. N, 7*, 1-33.
20. Chorievich Aslanov, S., Qobilovich Buxorov, A., & Ibodullaevich Fayzullayev, N. (2021). Catalytic synthesis of C<sub>2</sub>-C<sub>4</sub>-alkenes from dimethyl ether. *arXiv e-prints*, arXiv-2104.
21. Khamroev, J. X., Fayzullaev, N. I., & Haydarov, G. (2021). Texture Characteristics of Modified and Activated Bentonite. *Annals of the Romanian Society for Cell Biology*, 12160-12174.
22. Kh, K. J., Fayzullaev, N. I., Sh, K. G., Temirov, F. N., & Kh, J. M. (2021). Texture and Sorption Characteristics of Bentonite-Based Sorbents. *Annals of the Romanian Society for Cell Biology*, 828-849.
23. Temirov, F. N., Fayzullaev, N. I., Khaidarov, G. S., Khamroev, J. K., & Jalilov, M. K. (2021). Optimization of the Process Acid Activation of Bentonite. *Annals of the Romanian Society for Cell Biology*, 809-827.
24. Temirov, F. N., Fayzullaev, N. I., & Haydarov, G. (2021). Texture and Sorption Characteristics of Modified Bentonite Made by Ash-Gel and Together Equipment. *Annals of the Romanian Society for Cell Biology*, 12175-12185.

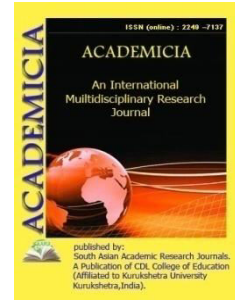

DOI: **10.5958/2249-7137.2021.01961.3**

## PRODUCTIVITY OF GRAIN OF WHEAT OF SAND OF CENTRAL FERGANA

Zokirova S\*; Kholmatova Sh\*\*; Ergasheva N\*\*\*

\*Doctor of Agricultural Sciences,  
UZBEKISTAN

\*\*Candidate of Agricultural Sciences,  
UZBEKISTAN

\*\*\*Researcher,  
FerSU, UZBEKISTAN

### ABSTRACT

*In connection with the proclamation of the independence of the Republic of Uzbekistan, the tasks of rational use of irrigated lands and self-sufficiency in agricultural products have acquired particular importance. As noted above, graded sands are highly susceptible to wind erosion. These lands should be approached from the point of view of soil conservation agriculture, sowing with ground cover crops. Ground cover crops, protecting the land from erosion, lead to a gradual increase in the fertility of the sands.*

**KEYWORDS:** *Proclamation, Acquired, Fertility, Independence*

### INTRODUCTION

In addition, the population of our country must be provided with bread, and animal husbandry with fodder.

Therefore, where earlier experiments were carried out with cotton after sowing sorghum, from 2002 to 2004. experiments were carried out with wheat of the Polovchanka variety.

In the third decade of June, wheat was harvested, the yield is shown in the table. 1.

**TABLE 1 MONITORING THE NUMBER OF WHEAT SEEDLINGS**

Variants	Seedlings per 1m <sup>2</sup> /pc	Number of stems after winter, m <sup>2</sup> /pc	Number of stalks before harvesting wheat, 1m <sup>2</sup> /pc.
N-0, P-0, K-0	450	370	320
N-120, P-120, K-60	475	425	390
N-160, P-160, K-80	580	520	480
N-200, P-200, K-100	550	480	450

The growth and development of wheat (Table 2) shows that on March 1, the difference in growth between the options is not large, however, on April 1, in the option where wheat was not fed (control), the height reached 55.1 cm, with the introduction of N- 120, P-120, K-60 kg / ha it was 6.5 cm higher, N-160, P-160, K-80-11.3, N-200, P-200, K-100 kg / hectare 13.1 cm higher than control, the same pattern was observed for growth and development on May 1 and June 1.

**TABLE 2 WHEAT GROWTH AND DEVELOPMENT**

Variants	Height, cm				Number, productivity of plants per 1m <sup>2</sup> / piece.
	1.03	1.04	1.05	1.06	
1	27	55,1	80,0	86,0	2
2	32	61,2	84,1	96,6	4,5
3	33	66,4	96,0	100,0	3
4	35	68,2	89,0	95,0	3,2

Table .3 shows the indicators for wheat. The length of an ear of wheat in the first and second variants is the same (8 cm), in the third variant by 0.4, in the fourth variant by 1 cm more than in variants 1 and 2 (Table 3).

**TABLE 3 SOME INDICATORS OF WHEAT**

Variants	Ear length, cm	Number of grains of one spike, pcs.	Grain weight of one spike, gr	Weight 1000 pcs. grains
1	10	33,4	26,7	33,6
2	11,5	38,8	28,9	36,1
3	12	40,2	29,7	39,6
4	12,3	39,1	29,3	40,0

Where wheat has not been fed, the amount of grain reaches 33.4, in the 2nd variant - 5.4; The third variant is 6.4 and on variant 4 it is 5.4 grams more than in the control. With an increase in the norms of mineral fertilizers, the yield of wheat increases (tab. 4).

**TABLE 4 PRODUCTIVITY OF WHEAT AND STRAW GRAIN, DEPENDING ON THE DEPTH OF THE SAND ON SOLID GROUND AND THE AMOUNT OF FERTILIZERS, C / HA**

Years	Variants	Sand thickness, cm
		Average by options
		50/75
1998	1	8,4/13,4
	2	19,8/31,6
	3	20,9/33,4
1999	1	9,1/14,6
	2	18,6/29,7
	3	17,2/27,5
	4	19,1/30,5
2000	1	10,1/16,2
	2	21,3/34,0
	3	22,5/36,0
	4	23,3/37,2

Note: the numerator is the straw yield, the denominator is the grain

In addition to the yield, the quality of the grain, wheat, plays an important role. In the control, where wheat was not fed with mineral fertilizers, the amount of protein reached 10.8%, in the variant N-120, P-120, K-60 kg / ha-at 0.2, in the variant N-160, P-160, K -80 kg / ha - 1.9 and variant N-200, P-200, K-100 kg / ha - 1.8% more than in the control variant.

The quality of the bread depends on the gluten content of the wheat grain. In the experience of growing wheat on various backgrounds in terms of gluten content, the difference is as follows: in the control variant, gluten reaches 21.1%, in other variants, respectively, 2.6%; 3.2 and 5.2 more control (Table 5).

**TABLE 5 WHEAT GRAIN QUALITY DEPENDING ON THE DEPTH OF THE SCREEN AND THE AMOUNT OF FERTILIZER (AVERAGE OVER 3 YEARS)**

Variants	Protein, %	Gluten, %	Fertilizing wheat with nitrogen
1	10,8	21,1	-
2	11,0	24,8	11.02, 9.04.03, 5.05.03, PK-12.03.03
3	13,7	25,6	11.02, 9.04.03, 5.05.03, PK-12.03.03
4	12,6	27,6	11.02, 9.04.03, 5.05.03, PK-12.03.03

## LIST OF REFERENCES

1. S. Zakirova, G. Yuldashev (Monograph 2004)
2. Xusanjonov, A. S., & Otaboev, N. I. (2018). IMPROVING OF STEERABILITY OF AUTOMOBILES WITH ROTATION OF X-TYPE OF HIS REAR WHEELS RELATIVELY OF FRONT WHEELS. *Scientific-technical journal*, 22(2), 131-133.
3. Khusanjonov, A., Makhammadjon, Q., & Gholibjon, J. OPPORTUNITIES TO IMPROVE EFFICIENCY AND OTHER ENGINE PERFORMANCE AT LOW LOADS.



4. Xusanjonov, A., Qobulov, M., & Ismadiyorov, A. (2021). AVTOMOBIL SHOVQINIGA SABAB BO'LUVCHI MANBALARNI TADQIQ ETISH. *Academic research in educational sciences*, 2(3).
5. Xodjayev, S., Xusanjonov, A., & Botirov, B. (2021). TRANSPORT VOSITALARI DVIGATELLARIDA DIMETILEFIR YOQILG'ISIDAN FOYDALANISH. *Scientific progress*, 2(1), 1531-1535.
6. Akhmedovich, M. A., & Fazliddin, A. (2020). Current State Of Wind Power Industry. *The American Journal of Engineering and Technology*, 2(09), 32-36.
7. Fazliddin, A., Tuymurod, S., & Nosirovich, O. O. (2020). Use Of Recovery Boilers At Gas-Turbine Installations Of Compressor Stations And Thyristor Controls. *The American Journal of Applied sciences*, 2(09), 46.
8. Dilmurod, R., & Fazliddin, A. (2021). Prospects for the introduction of artificial intelligence technologies in higher education. *ACADEMICIA: an international multidisciplinary research journal*, 11(2), 929-934.
9. Khusanjonov, A., Makhammadjon, Q., & Gholibjon, J. OPPORTUNITIES TO IMPROVE EFFICIENCY AND OTHER ENGINE PERFORMANCE AT LOW LOADS.
10. Мустафакулов, А. А., Арзикулов, Ф. Ф., & Джуманов, А. (2020). Использование Альтернативных Источников Энергии В Горных Районах Джизакской Области Узбекистана. *Интернаука: электрон. научн. журн*, 41, 170.

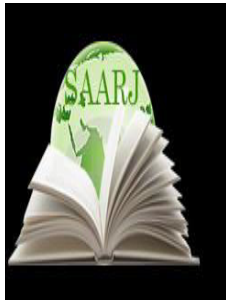

**ACADEMICIA**  
**An International  
 Multidisciplinary  
 Research Journal**  
 (Double Blind Refereed & Peer Reviewed Journal)

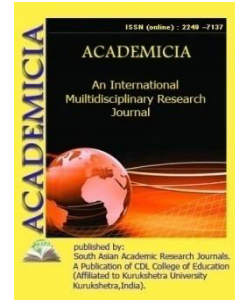

**DOI: 10.5958/2249-7137.2021.01962.5**

## WALNUT SPECIES IN THE FERGANA VALLEY, THEIR BOTANICAL CHARACTERISTICS

**Rajavaliyeva Z\*; Jamoliddinov R\*\*; Mamurova N\*\*\***

<sup>1,3</sup>FerSU,  
 UZBEKISTAN

### ABSTRACT

*The mountains, hills, and deserts that surround the valley vary in environmental conditions, soils, precipitation, and other characteristics. . Accordingly, the organs of plants are collected knowing when they accumulate the most substances. Therefore, it is not recommended to collect it at any time. In order to have a complete knowledge, we need to have sufficient knowledge of their comprehensive biology (growth, development, productivity, agrotechnics, methods of reproduction, promising varieties), ecology (their living conditions). Both species have produced a large number of species and varieties as a result of natural selection. These varieties are slightly higher than the varieties grown in countries such as France, Bulgaria, Germany, America.*

**KEYWORDS:** *Accumulate, Growth, Development, Productivity*

### INTRODUCTION

According to sources, the climate of the Fergana Valley is favorable for the cultivation of all flora. The valley has the ability to grow all agricultural crops due to its temperate climate, favorable climatic conditions and favorable soil conditions. Today in the Fergana Valley, in addition to providing the population with fresh fruit throughout the year as food products, depending on the growing demand of the population for the cultivation of fruit and vegetable crops and their yield, they are rich in quality oil and vitamins. It is also used as a valuable dye in food, bark and leaves. With this in mind, due to the growing demand for nuts and nut products, the expansion of arable land, the cultivation of wild species and their cultivation are widely practiced. The production of high-quality products from walnut trees, in particular, is becoming more and more popular.

The Fergana Valley is rich in useful plant species used for food and medicine. Many of these fruits are harvested from plants and processed to be used as food, to enhance the taste, flavor, aroma, and other purposes of food.

Some of them turn into delicious dishes after processing. As naturally occurring fruit-bearing plants contain nutrients for a variety of organisms, we try to use them all year round. Plants in the form of trees, shrubs and lianas mainly store nutrients in their flowers, fruits and seeds. But their composition and quantity change as they grow and develop. Accordingly, the organs of plants are collected knowing when they accumulate the most substances. Therefore, it is not recommended to collect it at any time.

The mountains, hills, and deserts that surround the valley vary in environmental conditions, soils, precipitation, and other characteristics. In particular, it differs from the Qurama, Turkestan, Alay mountain ranges, and other - Fergana, Chatkal mountain ranges by the lack of fruit trees. Fruit plants are mainly found in mountain ranges with high annual rainfall (400-1000 mm), and they form thick-growing walnut, almond, and pistachio trees.

It is known that walnut has a special place among the useful plants. Walnut plants have long been known in the Fergana Valley. Walnuts, almonds and pistachios are the most common fruit crops in the valley. They are one of the most popular fruit plants and one of the leading in all respects.

The fruits of the walnut plant are rich in fats, proteins and carbohydrates. They are much higher in calories than most foods. A variety of food industry from walnut kernels networks and in cooking.

One of the important features of nuts is that they can be stored for many years. It is not difficult to transport them over long distances.

Its wood is characterized by long-term durability and hardness.

Its leaves and young bark, as well as the fruit post, contain large amounts of preservatives, which are used in skin care and dyeing. The use of walnuts for orchards, landscaping of streets and roads, creation of reserves is very effective.

Walnut is one of the oldest fruit plants. The use and study of it also dates back to ancient times, and it is still used today.

The study is ongoing. That is why walnuts play an important role in the development of the national economy.

In ancient times it was mainly used for its fruit. But due to the lack of information about walnuts, unplanned use of walnuts, their natural regeneration, the creation of new varieties, the creation of cultivated walnuts, increasing productivity, zoning of created varieties, their enrichment, renewal. At present, we have some knowledge about the bioecology of walnuts, agro-techniques, the creation of new varieties, reproduction, increasing productivity at the expense of high-yielding varieties, but this knowledge is not enough for the effective use of nuts. In order to have a complete knowledge, we need to have sufficient knowledge of their comprehensive biology (growth, development, productivity, agrotechnics, methods of reproduction, promising varieties), ecology (their living conditions). This allows for effective use of learning resources.

Walnuts - Juglans plants belong to the walnut family. It has about 40 species and is a large tree plant, mainly distributed in the temperate, subtropical and tropical regions of the northern hemisphere.

Nut taxonomy. Walnut taxonomy was first studied by Dodle in 1909. He based his study of the taxonomy of nuts on their leaf morphology and divided the walnut family into 3 types. (Juglans regia, J. fallax Dode, J. kamao'nia Dode). In 1920, MG Popov recognized only one type of fire (Juglan) and distinguished two types.

(J. fallax Ca J. Turcomanica). To systematize them, MG Popov did not take into account the history and geographical distribution of species and subspecies. Subsequent studies have identified two types of walnuts (J. Regia and J. fallax Dode). The kernels of the fruit are slightly difficult to separate (the curtain between the kernels - the barriers are wooden). J. Gedta, on the other hand, appeared after the first round, formed from relatively arid-continental conditions, with a low pairing of leaves growing at altitudes of 600-2000 meters above sea level, thick and hard, and now a thin layer of barriers between carp and core. characterized by the presence of

Both species have produced a large number of species and varieties as a result of natural selection. These varieties are slightly higher than the varieties grown in countries such as France, Bulgaria, Germany, America. Today, there are more than a hundred forms and varieties of these two species, which differ in the shape of the fruit, the size of the core of the size, the stone-like, paper-like appearance of the endocarp.

Depending on the thickness or sparseness of natural walnut groves (where sunlight may or may not fall), there are shrubs that form a lower tier (layer) of trees, followed by tall grasses on the floor, then low tall grasses and finally algae, allowing the vegetation to be multi-layered.

Thus, the number of layers in the structure of the surface of natural coconuts may vary depending on the level of development of the coconut.

#### LIST OF REFERENCES

1. Zarubii A.F.-Vostanavlennie i razvitie orexovo - plodovix lesov yuj.Kirgizii M, 1954.
2. Prutenskiy D.I. Orex Grechskiy, Kazakhstan 1961.
3. Arifxonova MM -Rastitelnost Ferganskoy valley, 1967
4. Tuychiev M.T -O vozobnovlenie Grechskogo orexa v Srdney Azii T, 1960.
5. Kuznetsov V.V. - Walnut plants of Uzbekistan, 1956
6. Xusanjonov, A. S., & Otaboev, N. I. (2018). Improving Of Steerability Of Automobiles With Rotation Of X-Type Of His Rear Wheels Relatively Of Front Wheels. *Scientific-technical journal*, 22(2), 131-133.
7. Khusanjonov, A., Makhhammadjon, Q., & Gholibjon, J. Opportunities To Improve Efficiency And Other Engine Performance At Low Loads.
8. Xusanjonov, A., Qobulov, M., & Ismadiyorov, A. (2021). Avtomobil Shovqiniga Sabab Bo'luvchi Manbalarni Tadqiq Etish. *Academic research in educational sciences*, 2(3).
9. Xodjayev, S., Xusanjonov, A., & Botirov, B. (2021). Transport Vositalari Dvigatellarida Dimetilefir Yoqilg'isidan Foydalanish. *Scientific progress*, 2(1), 1531-1535.

10. Akhmedovich, M. A., & Fazliddin, A. (2020). Current State Of Wind Power Industry. *The American Journal of Engineering and Technology*, 2(09), 32-36.
11. Fazliddin, A., Tuymurod, S., & Nosirovich, O. O. (2020). Use Of Recovery Boilers At Gas-Turbine Installations Of Compressor Stations And Thyristor Controls. *The American Journal of Applied sciences*, 2(09), 46.
12. Dilmurod, R., & Fazliddin, A. (2021). Prospects for the introduction of artificial intelligence technologies in higher education. *ACADEMICIA: an international multidisciplinary research journal*, 11(2), 929-934.
13. Khusanjonov, A., Makhammadjon, Q., & Gholibjon, J. Opportunities To Improve Efficiency And Other Engine Performance At Low Loads.
14. Мустафакулов, А. А., Арзикулов, Ф. Ф., & Джуманов, А. (2020). Использование Альтернативных Источников Энергии В Горных Районах Джизакской Области Узбекистана. *Интернаука: электрон. научн. журн*, 41, 170.



**ACADEMICIA**  
**An International**  
**Multidisciplinary**  
**Research Journal**  
 (Double Blind Refereed & Peer Reviewed Journal)

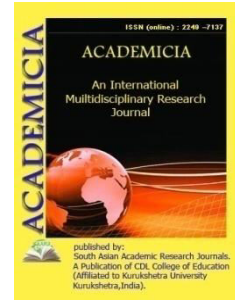

**DOI: 10.5958/2249-7137.2021.01963.7**

**AGROTECHNICS OF GRAPE GROWING ON STONE GRAVELY  
 BLACK GRAY SOILS**

**Abdurahimova M\*; Imyaminova\*\*; Rajavaliyeva Z\*\*\*; Alijonova M\*\*\*\***

<sup>1,4</sup>FerSU,  
 UZBEKISTAN

**ABSTRACT**

*The vine grows in one place for 40-50 years or more. Its longevity, productivity, cost-effectiveness, environmentally friendly production depend on the correct placement of vineyards, the right choice of location and varieties, attention to care. The construction of new vineyards is associated with high capital expenditures, especially in the current period of market reforms. It is very difficult to correct mistakes in this regard. Therefore, it is important to choose a place for the vineyard, cultivate the land, organize the vineyard area, select and place varieties, plant and care for seedlings in a timely manner, based on scientific and best practices.*

**KEYWORDS:** *Longevity, Productivity, Vineyard, Environmentally*

**INTRODUCTION**

The soil and climatic conditions of Uzbekistan allow growing varieties of grapes ripening at different times in all regions. The vineyard should be open, well-lit, fertile, and well watered. Sandy and rocky soils, mountains and foothills, which are considered unfavorable for crops such as wheat, cotton, sugar cane, flax, hemp, are also suitable for growing vines. Up to 100 slopes in mountainous and hilly areas can be used for vines.

Strongly saline for current, groundwater 1 m. above, lowlands are considered unusable. However, their reclamation status can be improved (Djavakyants Yu.M., Gorbach V 2001).

Selection of land for vineyards is carried out on the basis of technical and legal documents of the directive bodies. It defines the area of land allocated for the vineyard, the varieties and directions for their use (for the cultivation of edible, raisin and vinobop grapes). It will be considered and decided by a special commission. The selection of land for the vineyard takes into account such factors as its relief, the location of slopes, the depth and chemical composition of groundwater, soil and climatic conditions, water bodies.



In recent years, mountain slopes, rocky and sandy lands have been developed and used effectively in the construction of vineyards, as the quality of grapes on the slopes is better (juicy, colorful) than on flat lands.

The slope of the slope should be taken into account when choosing slopes. As the slope increases, so do the costs and labor involved in planting and maintaining the vineyard. Slopes of up to 100 are few, those of 10-200 are moderate and strong, those of more than 200 are very steep, and the establishment of vineyards in such places is associated with great difficulties and does not justify itself (picture) ). On low and medium slopes, power lines are laid across them. The purpose is to prevent soil erosion, waste of irrigation and rainwater, and loss of soil moisture, as well as to facilitate maintenance. The higher the slope (more than 100), the more terraces are formed. Stepped platforms are especially common. This method also protects the soil from erosion, promotes moisture accumulation, and facilitates maintenance.

Current growth, productivity, and crop quality largely depend on the nature and characteristics of the soil. In Uzbekistan, gray and meadow-grass soils are suitable for growing vines. The soil layer is 50-60 cm. It is also possible to grow high-quality crops on rocky soils of not less than 10 cm. When choosing a place for the vineyard should also pay attention to the wind regime. Areas with strong winds and not surrounded by protective trees are dangerous for vines.

A number of organizational and agro-technical works are carried out to prepare the land for planting (clearing the land of weeds and other plant residues, leveling the land, applying organic and mineral fertilizers, identifying irrigation facilities, etc.). Weeds should be 20-25 cm deep. plowed deep and cleaned of root debris. To do this, use plow harrows and cultivators. A mixture of legumes and legumes (peas, beans, soybeans, alfalfa, rye, etc.) is planted for 2-3 years on the old orchards, vineyards and shrubs. Many of them can be driven in the fall as green manure.

Vine can be planted after the reclamation of saline soils with close groundwater (1-1.5 m). Otherwise, the vines may not develop and may even die. This is due to the fact that the root system is damaged by lack of oxygen, and the salts in the groundwater are partially oxidized, which has a devastating effect on the roots. Drains are used to prevent such cases. There will be dehumidifiers, desalination and erosion ditches. Recently, plastic drainage pipes with a diameter of 40-50 mm are widely used. They are 1.5-1.8 m to the ground using DPBN-1.8 pipework. depth.

The vineyard is severely damaged by hot and cold winds, heavy rains (floods). To protect them, it is necessary to plant protective trees around the future vineyard. Several rows of forest trees and shrubs also protect the vineyard from snow, soil erosion and landslides.

In viticulture, mainly protective trees that regulate flow and wind are used. The first is mainly used in mountainous and foothill areas, where 3-5 rows of shrubs (cherry, currant, raspberry, willow, etc.) are planted at intervals of 1x0.5 m. Wind protection trees (a row of walnuts at a distance of 6 m, 2-3 rows of poplars, apricots, cherries at a distance of 1-2.0 m) will be planted along the territory of the quarters. The distance between protective trees should be 500-1000 m in flat areas and 200-300 m in mountainous areas. They are placed at a distance of 10 m from the vineyards (Buzin N.L., Pelyax M.A. 1956).

Before planting, the soil is plowed with organic and mineral fertilizers. In particular, deep tillage (60-70 cm) with a plantation plow improves the physical and chemical properties of the soil, air,

water, heat regimes, nutrient uptake by plants, enhances the activity of microorganisms in the soil, improves soil fertility. regulates water permeability and moisture retention, eliminates weed forgetfulness and bq

The best time for planting is autumn (November). Post-plowing soil loosens to allow more water to be absorbed into the soil and stored. During the winter, the soil level is maintained until the seedlings are planted in the spring. Deep plowing of the land with a plantation is preferable to 2-3 months between planting. It is not recommended to plant seedlings on a white background. This is because when the soil settles, the growing roots are cut off and the plant does not grow well. Frozen or snow-covered lands are usually not planted. Before planting, 30-40 tons of rotten manure, 500-600 kg of superphosphate or ammophos and 90-100 kg of potassium salt are applied per hectare.

Planting was carried out using plantation plows PP-50PG, PPN-50. They are used in attachment to T-100M or T-100 type tractors. RN-80B softener or UOM-50 machine is also used for deep loosening of the soil layer without overturning (up to 80 cm). Before planting, the area is divided into piles (400-500 m long and 30-40 m wide). It is not allowed to drive the earth on the plant plow. Because of poor quality plowing, the unit can break down quickly (Tursunov G. Temurov Sh 1972).

This responsible work is carried out in accordance with the development plan of the farm and must meet the requirements of modern technology of vineyard care. It is better to have a large, integrated area for the vineyard. This greatly simplifies the work, such as better organization of work, efficient use of labor and mechanization, crop preservation. As vines require a lot of labor, it is advisable to place the vineyard closer to the settlement.

Once the land is allocated for the vineyard, a plan for the organization of the vineyard area is developed. Vineyard plots, quarters and maps, road networks, water sources, protective tree plantations, field sheds, warehouses, etc. determined. In designing them it is necessary to take into account the low-altitude of the allocated area, soil layer, varietal characteristics of the current.

In order to facilitate the organizational and maintenance work, the area allocated for the vineyard is divided into blocks of 20-25 hectares, which in turn are divided into 3-5 hectare plots. Quarters 12-15 in the mountains and foothills. is defined as On flat lands, the block should be rectangular in shape and should not exceed 400 m in width and 700 m in height. The maps are 300-500 m long and 100 m wide. Roads will be 8 m wide between blocks, 5 m wide between cards, and 10 m wide at the edge of the field.

It is important to mark the current line correctly. In flat areas where the retention of soil moisture does not depend on the terrain, the power lines are placed from north to south. In this case, the vine makes good use of light throughout the day. In irrigated areas, rows of vines are placed along the irrigation ditches facing the wind. Permanent irrigation points are located at the edge of the block, and temporary irrigation points are located along the road between the maps. Roads should cover 7-8% of the total vineyard area.

On the slopes, vines are laid across them to protect the soil from erosion and to trap atmospheric precipitation.

It is also important to ensure airflow, ie, air drainage, to combat spring frosts and fungal diseases. To do this, every 200 m at the intersection of protective trees. and 20 m. space should be left. Special geodetic instruments are used to accurately perform all the work described above. (Yusupov X.S., Kats Ya.F., Preobrazhensky A.A. Juravel M.S. 1960)

#### LIST OF REFERENCES

1. Smirnov KV, L.M. Maltabar and others. Vinogradarstvo M 1998.
2. Smirnov KV, TI Kalmikova and others. "Vinogradarstvo" M 1987.
3. Rybakov A.A. "Viticulture of Uzbekistan". "Labor" 1969.
4. Xusanjonov, A. S., & Otaboev, N. I. (2018). Improving Of Steerability Of Automobiles With Rotation Of X-Type Of His Rear Wheels Relatively Of Front Wheels. *Scientific-technical journal*, 22(2), 131-133.
5. Khusanjonov, A., Makhammadjon, Q., & Gholibjon, J. Opportunities To Improve Efficiency And Other Engine Performance At Low Loads.
6. Xusanjonov, A., Qobulov, M., & Ismadiyorov, A. (2021). Avtomobil Shovqiniga Sabab Bo'luvchi Manbalarni Tadqiq Etish. *Academic research in educational sciences*, 2(3).
7. Xodjayev, S., Xusanjonov, A., & Botirov, B. (2021). Transport Vositalari Dvigatellarida Dimetilefir Yoqilg'isidan Foydalanish. *Scientific progress*, 2(1), 1531-1535.
8. Akhmedovich, M. A., & Fazliddin, A. (2020). Current State Of Wind Power Industry. *The American Journal of Engineering and Technology*, 2(09), 32-36.
9. Fazliddin, A., Tuymurod, S., & Nosirovich, O. O. (2020). Use Of Recovery Boilers At Gas-Turbine Installations Of Compressor Stations And Thyristor Controls. *The American Journal of Applied sciences*, 2(09), 46.
10. Dilmurod, R., & Fazliddin, A. (2021). Prospects for the introduction of artificial intelligence technologies in higher education. *ACADEMICIA: an international multidisciplinary research journal*, 11(2), 929-934.



**ACADEMICIA**  
**An International**  
**Multidisciplinary**  
**Research Journal**  
 (Double Blind Refereed & Peer Reviewed Journal)

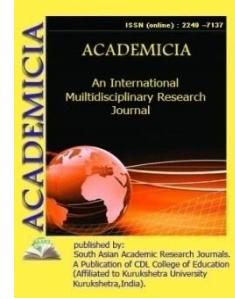

**DOI: 10.5958/2249-7137.2021.01964.9**

## THEORETICAL FOUNDATIONS OF THE ACCELERATION SLIP REGULATION SYSTEM

**Abdulaziz Solijon ogli Khusanjonov\***; **Shohruhbek Ilhomjon ogli Nosirjonov\*\***

\*Assistant,

Department of Ground transport systems and,  
 Their exploitation at the Fergana polytechnic institute,  
 UZBEKISTAN

\*\*Assistant,

Department of Ground transport systems and,  
 Their exploitation at the Fergana polytechnic institute,  
 UZBEKISTAN

### ABSTRACT

*In this work discusses the structure of the acceleration slip regulation system used in modern cars and the principle of its operation. The purpose is to prevent the vehicle, especially the high-powered vehicle from starting, to accelerate the wheel slip to maintain the stability of the vehicle's driving direction, to maintain good handling and the most suitable driving force to ensure safe driving. Most acceleration slip regulation methods are based on slip ratio control. This method requires the vehicle speed, which can be obtained using the speed of the driven wheels or vehicle speed sensors. Since all the forces are used by the driving force, the steering force of the turning is lost, so the steering force that causes the vehicle to turn or maintain the direction of the vehicle will be lost, which may cause the direction of the vehicle to be unstable.*

**KEYWORDS:** *Transport Vehicles, Technical Exploitation, Technical Condition, Control.*

### INTRODUCTION

Because of the growing public concern about the global environmental and energy problems, electric vehicles have become a hot research topic. Significant improvements in power electronics and power and control strategies have been achieved, which have promoted the development of electric vehicles. Accelerated slip adjustment, or accelerated stability retainer, as the name implies, is a control system that prevents the drive wheel from accelerating and sliding. The purpose is to prevent the vehicle, especially the high-powered vehicle from starting, to

accelerate the wheel slip to maintain the stability of the vehicle's driving direction, to maintain good handling and the most suitable driving force to ensure safe driving. As a new research area for electric vehicles, the distributed drive electric vehicle, which employs motors to drive the wheels independently, is drawing increasing attention because of its advantages, which include a flexible chassis layout, quick torque response, easy measurements, and vehicle dynamic control with multiple degrees of control freedom due to the independent wheel torque control [1,2].

It was originally invented by Bosch in Germany. It was originally a German term and its full English name is usually considered the Acceleration Slip Regulation. Sometimes you will see a few abbreviations with similar meanings, such as Mercedes-Benz's ASC acceleration taxi control system, The name of ASR follows this. The product of a lot of advances in technology.

### **Methods**

This system is called by different names by many manufacturers. But the principle of their operation is the same, for example:

- Audi: (ASR)
- BMW: Automatische Stabilitäts Control (ASC)
- Fiat: (ASR)
- Hyundai: (TSC)
- Mazda: Traction Control System (TCS)
- Mercedes-Benz: (ASR)
- Nissan: Traction Control System (TCS)
- Opel/GM: Traction Control Support System (TCSS)
- Peugeot: (ASR)
- Porsche: ASR als Teil des Porsche Stability Management (PSM)
- Saab: Traction Control System (TCS)
- Renault: (ASR)
- Suzuki: (ASR)
- Toyota: Traction Control (TRC)
- Volkswagen: (ASR)
- Volvo: Traction Control System (TRACS)

### **DISCUSSION**

Electronic engine controls are often used in articulated buses but increasingly also for other motor vehicles. The mechanical linkage between the accelerator pedal and the fuel-injection pump is then dispensable apart from a short link between the electrical control motor and the pump adjusting lever.

The mechanical linkage is replaced by an electrical set point generator on the accelerator pedal (potentiometer) and a control motor fitted close to the fuel-injection pump.

The control signal set by the ABS/ASR ECU is then relayed via digital interface to the ECU of the drive-by-wire system which in turn now transmits the corresponding control commands to the control motor.

Simply distribute, ASR looks like one or a few differential locks. It distributes the driving force of the engine to one or more wheels in an optimal manner, and the ASR is particularly advantageous on a flat road. The reason is the same as the reason In addition to the driving force for advancing the vehicle; the general tire should also produce a vehicle. Turning force of the turning or the braking force for stopping the vehicle, whether it is simply generating the driving force, the steering force, the braking force, or the driving force and the steering force, the braking force and the steering simultaneous exerting force, Under certain load conditions, that is, when the current emergency start causes the tire to slip, the force is determined, and this sliding phenomenon means that all the grip of the tire is used in the driving force, and therefore, the car can be controlled at this time. Since all the forces are used by the driving force, the steering force of the turning is lost, so the steering force that causes the vehicle to turn or maintain the direction of the vehicle will be lost, which may cause the direction of the vehicle to be unstable.

In deep snow or in similar conditions the traction force can be increased by actuating the "ASR off-road" button which is available as an option. If this button is activated, the ECU changes the conditions (slip thresholds) for ASR control to permit higher slip ratios. The ASR lamp flashes in regular cycles while the button is actuated to indicate to the driver that stability may be reduced.

Moving the car ( $\lambda_{an}$ ): in this case it depends on the coefficient of adhesion or friction of the car wheels to the road surface.

The percentage of wheel speed to the speed of the car shifting the weight of the car is calculated by the following formula:

$$\lambda_{an} = \frac{V_w - V_F}{V_w} \cdot 100 \%$$

(1)

$V_w$  – wheel speed,

$V_F$  – vehicle speed

Weight coefficient of account ( $\mu_{an}$ ).The traction-adhesion coefficient and thus the propulsion power depends on the same factors as the braking force coefficient described above.

Analysis. When the wheels spin heavily ( $\lambda_{an} = 100\%$ ), the adhesion will be reduced significantly below the maximum value. The cornering force coefficient also falls as drive slip increases, and by the time the wheels spinit is negligible.

ASR control Drive slip regulators influence the acceleration events only if certain threshold values of the wheel slip or the wheel acceleration are exceeded.

Electronically operated solenoid valves brake the respective wheel proportionately or reduce the engine performance until the stable adhesion range is reached again [2].



If the event of further regulating action, the wheel is held in the proximity of the maximum possible adhesion within a slip range that is as narrow as possible.

When the vehicle is running on a low friction road, if the driving torque exceeds the maximum torque provided by the road, the driving wheels will experience excessive spin.

This excessive spin of the driving wheels will lead to a decrease in the longitudinal driving force and lateral stability of the vehicle, so it is necessary to prevent the excessive spin of the driving wheels. Because the longitudinal force is mainly affected by the slip ratio, directly controlling the slip ratio is an effective and widely used way to achieve better acceleration performance. To obtain the slip ratio of the driving wheels, it's necessary to measure the rotational speed of the driving wheels and the speed of the vehicle.

The speed of each wheel can be measured by wheel speed sensor and the speed of the vehicle can be calculated out by the speed of driven wheels.

The dynamics of a wheel during traction is modeled as Figure 1.

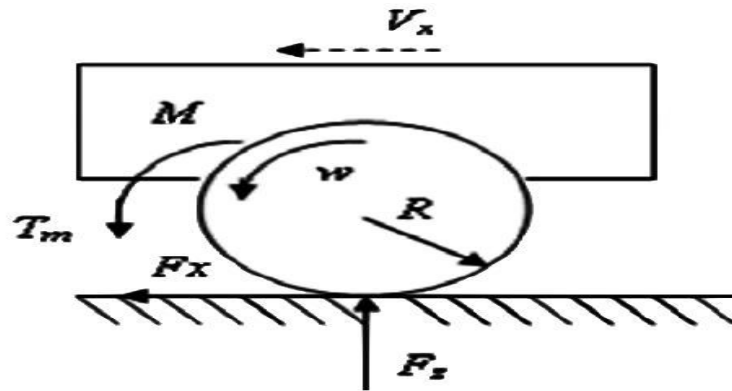

Figure 1. Single wheel model

$$MV = F_x \quad (2)$$

$$I_w \omega = T_m - F_x R \quad (3)$$

$$\lambda = (\omega R - V) / \omega R \quad (4)$$

Where  $M$  denotes 1/4 vehicle mass, kg,  $V_x$  represents the longitudinal velocity, m/s;  $F_x$  is the longitudinal road friction force, N;  $I_w$  is the wheel rotational inertia,  $\text{kg}\cdot\text{m}^2$ ;  $\omega$  is the angular rotational speed of wheel, rad/s;  $T_m$  represents the traction torque generated by the motor,  $\text{N}\cdot\text{m}$ ;  $R$  is the wheel radius, m;  $\lambda$  is the generally denoted slip ratio when traction.

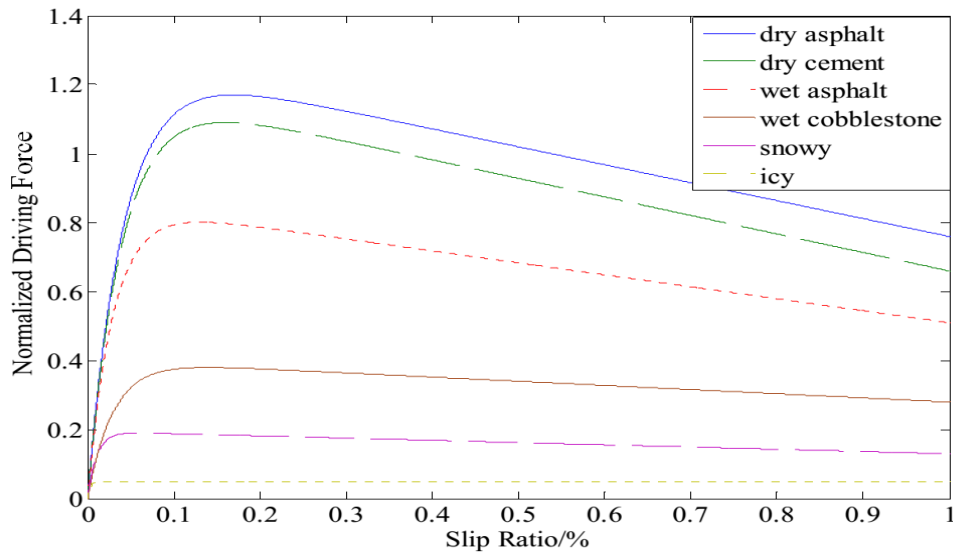

Figure 2. Longitudinal static curve of tire

Figure 2 shows the typical tire-road friction coefficient as a function of the slip ratio. Although slip slope and the value of optimal slip ratio vary with the road conditions (dry, wet or icy), road type (asphalt, concrete, gravel, or earth), tire types, and many other factors, the shape of the curve is similar, in all conditions the slope of the longitudinal static curve is first increasing in stable region and then decreasing in the unstable region.

**TABLE 1**  
**FITTING COEFFICIENTS AND PARAMETERS**

№	Road condition	C1	C2	C3	$\lambda_{opt}$	$\mu(\lambda_{opt})$	$\mu(\lambda_0)/\mu(\lambda_{opt})$
1	Dry asphalt	1.2801	23.990	0.5200	0.17	1.1700	99.74%
2	Wet asphalt	0.857	33.822	0.347	0.13	0.8013	99.79%
3	Dry cement	1.1973	25.168	0.5373	0.16	1.09	99.91%
4	Wet cobblestone	0.4004	33.708	0.1204	0.14	0.38	99.95%
5	Snowy	0.1946	94.129	0.0646	0.06	0.1906	97.01%
6	Icy	0.05	306.39	0.001	0.03	0.05	99.7%

## CONCLUSION

Acceleration slip regulation is an important aspect of vehicle dynamic control. It can help to prevent excessive wheel spin and to make full use of the road grip when the driver torque command exceeds the maximum torque provided by the road. Compared to conventional vehicles, the sensitive torque response and accurate torque control make the acceleration slip regulation of the electric vehicle faster and more accurate. Most acceleration slip regulation methods are based on slip ratio control. This method requires the vehicle speed, which can be obtained using the speed of the driven wheels or vehicle speed sensors.

**REFERENCES**

1. Hurmamatov, A. M., & Hametov, Z. M. (2020). Definitions the division factor at purification of oil slime of mechanical impurity. *ACADEMICIA: An International Multidisciplinary Research Journal*, 10(5), 1818-1822.
2. Xametov, Z., Abdubannopov, A., & Botirov, B. (2021). YUK AVTOMOBILLARINI ISHLATISHDA ULARDAN FOYDALANISH SAMARADORLIGINI BAHOLASH. *Scientific progress*, 2(2), 262-270.
3. Hurmamatov, A. M., & Hametov, Z. M. (2020). Results of preparation of oil slime for primary processing. *ACADEMICIA: An International Multidisciplinary Research Journal*, 10(5), 1826-1832.
4. Файзиев, П. Р., Исмадиёров, А., Жалолдинов, Г., & Ганиев, Л. (2021). Солнечный инновационный бытовой водонагреватель. *Science and Education*, 2(6), 320-324.
5. Xodjayev, S., Xusanjonov, A., & Botirov, B. (2021). TRANSPORT VOSITALARI DVIGATELLARIDA DIMETILEFIR YOQILG'ISIDAN FOYDALANISH. *Scientific progress*, 2(1), 1531-1535.
6. Xusanjonov, A., Qobulov, M., & Ismadiyurov, A. (2021). AVTOMOBIL SHOVQINIGA SABAB BO'LUVCHI MANBALARNI TADQIQ ETISH. *Academic research in educational sciences*, 2(3).
7. Chau, K.T.; Chan, C.C.; Liu, C. Overview of permanent-magnet brushless drives for electric and hybrid electric vehicles. *IEEE Trans. Ind. Electron.* 2008, 55, 2246–2257.
8. Lingfei W., Jinfang G., Lifang W., Junzhi Z. Acceleration Slip Regulation Strategy for Distributed Drive Electric Vehicles with Independent Front Axle Drive Motors. *Energies* 2015, 8, 4043-4072.

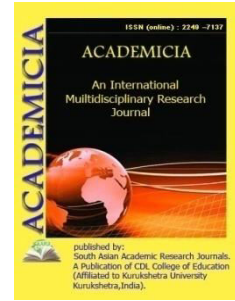

DOI: **10.5958/2249-7137.2021.01965.0**

## ETHNOGRAPHIC FOLKLORISTS IN THE NOVELS OF THE INDEPENDENCE PERIOD

**Turayeva Iroda Shermatovna\***

\*Independent Researcher of Karshi State University,  
UZBEKISTAN

### ABSTRACT

*This article deals with exploring the peculiarities of Uzbek folklorist. Independence years have been taken as an example. A great many novels have been investigated. Some actual actions, as well as the significant heroes' characteristic are described. The writer of fiction, on the other hand, is allowed greater freedom of expression and imagination. She is expected to personalize general experiences, permitted to develop his own style and eccentricities, and encouraged to avoid technical formulations and conventions in making his own commitments. That's the tone the scale of the grandmother's loneliness and unhappiness, the depth, the depth of the tragedy allowed to feel and dream. It is known that there is no consistency in the human imagination.*

**KEYWORDS:** *Folklorist, Novels, Genres, Novelty, Ancestors, Folklore.*

### INTRODUCTION

Folklore is a diverse literary genre and multifunctional in the history of human society as a phenomenon manifested in genres is the art of speech with a socio-aesthetic significance. It is all the time has also expressed the aspirations of the people who are its creators, as well as not only for the people themselves, but also for the children serves as an important educational tool in the formation of Children are a nation studying the life experiences of their ancestors, the science of labor and struggle from their work are coming.

They are from folk songs, epics and fairy tales from the narrations of love, sincerity, humanity, patience, contentment, hard work devotion, and most importantly, the realization of the feelings of the Fatherland in which their fathers lived and prospered his great ancestors Tomaris, Shirak, who fought for the freedom and liberty of the country. Spitamen, Muqanna, Temur Malik, Jaloliddin Manguberdi, Mahmud Torobi and They are learning from the courage of Amir Temur, living and creating romance [1.25p]. Consequently, folk art dates back to ancient times still for

children, too, an appreciation of goodness and a hatred of evil is a lesson that is constantly being refined and perfected from generation to generation.

As the word of mouth spreads, the national spirit of the people deepens. Reflecting on the spiritual and moral heritage of generations for centuries came as an example of community creativity, folk wisdom, talent and language richness has become a means for the people to understand themselves, love their history remained, most importantly, the genetic basis in the creation of written literature served [4.143p].

However, collecting and publishing samples of Uzbek children's folklore and the study of scientific and aesthetic value has long been neglected. Although it began in the late first quarter of the twentieth century, it has continued unabated did not become a process. It should also be noted that the season among folklorists and when it comes to ceremonial songs, their creators are always adults or restricting children's singing in the field by acknowledging that or there are cases of complete denial. Yes, adults do organized by.

Their routines, customs and it is true that the songs were written by adults. But keep in mind that this none of the ceremonies took place without the participation of children; at least, the children who attended it as spectators and the work that adults did. When they saw it, they later performed it as a model in the game, the same is true of those who compose songs according to their precepts [7.47p]. Therefore, the children also began to have their own ceremonial and seasonal songs. This the transition of the process, the change of living conditions, the new social due to the birth of the relationship, this or that ceremony is completely over that is, as a result of loss, or simply loss of prestige among adults even more so when the ceremony takes the form of a children's play or performance deepened.

Adults have always thought of their children - work and creativity engaged in it is about the child and their destiny as the obligation to grieve deepens caused the songs to weave. Especially baby care the responsibility was enormous.

The prose of the independence period is also a weighty and weighty type of today's literary process. Current in the literary process Sh. Kholmiraev, Utkir Hoshimov, Omon Mukhtor, Muhammad AH, Tohir Malik, Uncle Murod, Murod Muhammad Dost, Asad Dilmurod, Normurod Norkobilov, Khurshid Dostmuhammad, Ahmad Azam, Nazar Eshanqul, Ulugbek Hamdam, Luqman Works created by such artists as Borikhan, Zulfiya Kurolboy qizi promotes the development of national prose [5. 72p].

N. Eshanqul - the period of national independence brought a new tone to Uzbek prose. His story of "You Can't Hold the Wind" is a bubble of expression, a person taken to the center of the image in addition to the absolutely unexpected depiction of nature, one is also one with the uniqueness of the tone astonishing. So far, this analysis has been multi-layered, subtle, with the rhythm of the story itself there was no example of prose in our national literature that could create an artistic mood. N. Eshanqul enriched our prose with a tone that reflects the peculiarities of the Uzbek nation is unequal in terms of the possibility of delivery.

No matter how deeply his experiences and reflections in the 'field' change her perceptions and enrich her personal life, she must strive to be 'objective' by the standards of his colleagues in the craft. The writer of fiction, on the other hand, is allowed greater freedom of expression and imagination. She is expected to personalize general experiences, permitted to develop his own

style and eccentricities, and encouraged to avoid technical formulations and conventions in making his own commitments. His ideas may change without the criticism of inconsistency and her characters may express contradictions without evoking acrimonious reviews by scholars of other schools. He need not explicitly distinguish between ideas and emotions and may deliberately use the ambiguity of words to extend the reader's perception. In the same way as the image of the majestic, multi-layered aesthetic pressure in the expression, the moods the fact that it was given in a continuous chain gave a special tone to the story. That's the tone the scale of the grandmother's loneliness and unhappiness, the depth, the depth of the tragedy allowed to feel and dream. It is known that there is no consistency in the human imagination. In many cases, the human imagination cannot be controlled, but the imagination leads the person. Thus, in our national literature, from the outside at first glance, an impressionable disobedience to an artistic goal, but in fact, a thoughtful man a unique work depicting scenes of thought and emotion was born.

Like any man in life, the protagonist of the story has no control over his thoughts, the author it does not sit around sorting out fantasies. A picture of the process of moving from thought to thought, from imagination to imagination the characteristics of the protagonist's own nature are brighter than the sorted artistic regularity shows. There are so many situations in life when a person has the same inside and out, the same language and the same heart rare. Any person can only be himself in his thoughts. It is an uncontrollable stream of thought returns to itself only when left alone with. In this case, only the person reflected will be able to fully understand. The works of Ulugbek Hamdam are the characters of the national prose are good examples of an in-depth examination of psychology.

#### REFERENCES:

1. Askarov A. History of Uzbekistan. (From the earliest times to the 5th century AD). - T. Teacher. 1994.
2. Doniyorov A.X. Historiography of the history of the peoples of Central Asia. Textbook. T., 2020
3. Doniyorov A.X., Boriyev O., Ashirov A.A. Ethnology, ethnogenesis and ethnic history of the peoples of Central Asia. Textbook. Tashkent, 2020.
4. History of the Middle Ages (History of Uzbekistan). Guide. - Tashkent, 2007. 10. Guboglo, M.N. Ethnology and the present. On the outcomes of the II Russian congress of ethnographers and anthropologists (Ufa, 1-5 June 1997)] (1998) Etnograficheskoe Obozrenie, (3), pp. 129-147.
5. Saidov Sh. History of the peoples of Central Asia. T., TDSHI, 2010.
6. Sultanov F., Bozorboyev F. 0 'Rulers of Uzbekistan. - Tashkent, 2007.
7. Khodjayev A. Preliminary data on the history of the peoples of Central Asia, T., part 1-2, 2014.-332 p.
8. <https://fayllar.org/otmu-prttfpxxiirl-jilnhfiiya-fanlari-doktori.html?page=14>



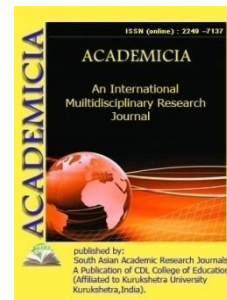

DOI: [10.5958/2249-7137.2021.01966.2](https://doi.org/10.5958/2249-7137.2021.01966.2)

## CONSIDERATION OF SPEECH ANALYSIS IN LINGUISTICS

Narzullayeva Diyora Zayniddin kizi\*

\*Teacher,  
Samarkand State Institute of Foreign Languages,  
UZBEKISTAN

### ABSTRACT

*The present article is devoted to an actual theme of modern linguistics - the main problems in speech analysis. More attention is paid to the syntactic analysis of a sentence the basic principles of comparative study of languages at the syntactic level and linguistic methods used in the analysis of tenses. Theoretical parts of the article are proved by examples. The classification of these secondary parts is related to the content and structure of the sentence and is based on a number of semantic and lexical-grammatical features. So, there are many unresolved cases in the analysis of speech analysis into primary and secondary parts.*

**KEYWORDS:** *Speech, Grammar, Syntactic Units, Subject, Predicate, Syntactical Unit, Component, Linguistic, Speech Components, Analyze.*

### INTRODUCTION

More and more attention of the world linguists is paid to the main problems in speech analysis. In world linguistics, in all practical and theoretical grammars, syntactic analysis of speech refers to the analysis of all syntactic units involved in the sentence into primary and secondary parts at all stages of the entire educational system. In the syntactic analysis of a sentence, it has become a tradition in all languages to divide the analysis into primary and secondary parts. However, in analyzing these passages, linguists have not come to a single conclusion, that is, although English scholars recognize the possessive and participle of a sentence. So, there are many unresolved cases in the analysis of speech analysis into primary and secondary parts. In particular, many linguists have expressed differing views on the issue of distinguishing a case from a complement.

The problems in speech analysis have been investigated for many years. Some of Russian and Uzbek linguists chose them as object of investigation: A. Kholodovich (1979), A. Peshkovskiy (1956), A. Shaxmatov (1941), G. Zolotova (1982), A. Nurmanov (1988), J. Buronov (1974) and

others. The results of their researches shows the differential analysis of the lexical, morphological, and syntactic layers of a particular language is overlooked, leading to such controversial issues. Focusing on the history of the analysis of the speech device by dividing it into primary and secondary parts, according to A.A. Kholodovich, "Objective criteria of the main secondary members of the prediction of Russian linguistics in the second half of the XIX century" [2, p.287].

Though, we see that the syntactic analysis of a sentence is divided into primary and secondary parts, starting with Russian linguistics and then spreading to other languages. Some English scholars, only distinguish subject and add other parts of speech to the predicate. According to H. Whitehall:

For example: The reporter gave the lady a present the reporter-subject, gave the lady a present-predicate, the lady –inner compliment,

A present-external compliment [5, p.345], while P. Roberts forms the units which participated in the sentence according to the morphological expression [7, p.17]. Such an approach by these scholars to the syntactic analysis of a sentence is not a syntactic but a morphological analysis. Some linguists also have only a Subject in the main parts and recognize the Predicate section, calling the secondary parts Modifiers and dividing them into three groups according to their morphological features:

- “1) Attributive Adjective modifiers, which modify a noun or a pronoun;
- 2) Objective modifiers, which modify a verb, an adjective or an adverb;
- 3) Adverbial modify - a verb, an adjective or another adverb” [7, p.72].

R.V. Zandworth also acknowledges the possessive and participle of the sentence and calls the secondary parts “Adverbial adjuncts” [6, p. 421].

Today, it is well known that the primary parts have, and if the predicate is understood, the secondary parts include the filler, the determiner, and the case. The classification of these secondary parts is related to the content and structure of the sentence and is based on a number of semantic and lexical-grammatical features. In Russian linguistics, the concept of secondary parts is emphasized differently by representatives of the two linguistic schools. While F.I Buslaev and M.B. Badhen differentiate secondary parts from the logical-grammatical principle, from questioning according to meaning and from identifying ways of syntactic units interrelationships, other school representatives prefer to rely on morphological means and the proportionality of word groups to parts of speech [1, p. 202].

According to A. Nurmanov, in structural linguistics the structural elements of speech are studied in terms of parts of speech or syntactic position, elements of propositive structure isomorphic to the structure of objective reality, communicative (actual) structure in terms of theme (known) and rheme (new), modal structure and objective and subjective relations [3, p. 211]. In addition, in linguistics, the term “predicate” has more than a dozen different interpretations.

G.A. Lobonova noted that the predicate is manifested in the ontological aspect as a sign, and in the logical aspect as a specific task [7, p. 114].

According to A. Shakhmatov, "... is defined as a psychological subject-imagination, which, by its nature, is the ruler of the performance expressed by the predicate" [6, p.525]. By this the scholar means that the name of a subject in a sentence is always grammatically relative to the verb or adjective with which it is associated. So, the psychological subject perceived by the subject, and the idea expressed about the sign, remains a psychological predicate. However, if we consider that the syntactic relations recognized by them are the study of the syntactic relations of syntactic units and their functions, such as adaptation, adhesion and control, the larger syntax includes pragmatic, cognitive, linguacultural, discourse, deictic and stylistic phenomena of the text and its constituent units. In this work, we are mainly working within a small syntax.

Most English scholars have argued that the presence of a complement depends on the lexical meaning of the verb in place of the participle, that is, that only transitive verbs require a complement in the sentence, and that the complement, as noted above, leads to many difficulties in syntactic analysis.

In this regard, U. Usmanov notes: "In the process of syntactic analysis of a sentence, it is obvious that it is not expedient to determine the complement based on the method of questioning, word order, lexical meaning of the verb [4, p.66].

**For example:** I want you to come (complex object);  
She sleeps a sound sleep (cognate object).

If we look at the syntactic analysis of sentences, "you to come" is a separable syntactic unit, there is a predicative between you to come or sleeps in the second sentence is an intransitive verb.

**Alternatively:** I write him a letter I write a letter to him

The fact that in the first sentence he is called an indirect object and in the second sentence he is called a prepositional object does not give complete satisfaction to the reader. In our view, the above-mentioned controversial problems arise as a result of the fact that speech analysis is carried out from the syntactic level to the morphological level. Instead, it is expedient to study the semantics of the syntactic unit at the syntactic level and its variants, and only if we continue to look at the syntactic semantics we will enrich the syntax of any language". If we consider the determiner as one of the secondary parts, it is emphasized that it refers to properties such as the sign, quality, quantity, relevance of the object. At this point, the part being identified is called defined. The relationship between the determiner and the determinant is called the attributive relationship. In this regard, the adjective or attributive relation of the determiner to the definite is also considered at the level of the phrases. The determiner is mainly represented by adjectives, adjectives (I-II), possessive, show, interrogative, conjunctive, relative pronouns, counting and ordinal numbers, nouns, prepositions, infinitive, infinitive devices, and adjective adverbs. In addition, the interpreter is also a type of determinant, which is studied by linguists as dense (inseparable) and separable interpreters. It is clear that this issue is also a controversial issue.

In fact, when comparing the meanings of grief, place, and time with style, the occurrence of the process expressed in the sentence reflects the situation that occurs directly in the action itself, without expressing the place, time, or condition. Because it is a description of a specific process, it stands close to the determinant.

In addition, in Russian linguistics, the category of case is interpreted differently. The adverbial connection in them does not correspond to the meanings represented by the case, and it is necessary to deduce the concept of attributive connection from its structure. This is because the elements associated with the attributive connection represent the identifier. From the above facts and considerations, it is clear that in linguistics there is no uniformity in the classification and classification of case categories. This is the case in linguistics and its classification is still there is a contentious issue, and the case is a category that has not been fully resolved.

So, in the present article we have a brief discussion of the main problems in the analysis of speech in world linguistics, the classification of the tense and its translation, the basic principles of comparative study of languages at the syntactic level and linguistic methods used in the analysis of tenses. In the syntactic analysis of a sentence, it has become a tradition in all languages to divide the analysis into primary and secondary parts. Identification is the main task of the researcher. In our work, we analyzed the main problems in speech analysis.

#### **REFERENCES:**

1. Buslayev D., Badhen. R. The grammar of Russian// 1959.286 p.
2. Kholodovich A.A. Problems of grammatical theory. Leningrad. 1979.-303 p.
3. Nurmonov A., Maxmudov N. And heads. Semantic syntax of the Uzbek language. T.: Fan, 1992.-292 p.
4. Usmonov U. Problems of relativity and incomplete propositions // Materials of scientific-theoretical conferences. Samarkand: SamGIYa, 1999.-p.p. 63-70.
5. Whitehall H. Structural Essentials of English. New York. 1956.-394 p.
6. Zandvoort R.W. A Handbook of English Grammar. Croningen, 1998.-436 p.
7. Zhilin I.M. Variability in the syntax of the modern German language. - Inostr. Yaz. At school. 1990.-85 p.



**ACADEMICIA**  
**An International  
 Multidisciplinary  
 Research Journal**  
 (Double Blind Refereed & Peer Reviewed Journal)

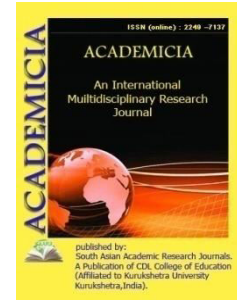

**DOI: 10.5958/2249-7137.2021.01967.4**

**EDUCATION OF YOUTH IN ISLAM**

**Bahauddinov Shamsuddin Salievich\***

\*Doctoral Student of Nukus State Pedagogical,  
 Institute named after Ajiniyaz,  
 UZBEKISTAN

**ABSTRACT**

*This article provides recommendations for educating young people. In particular, the responsibilities of parents in the upbringing of young people were revealed. Aspects of parenting in parenting were outlined. Existing problems in the upbringing of young people were pointed out. The solutions to these problems are based on Islamic sources. Data were obtained from reliable sources.*

**KEYWORDS:** *Child, Young, Upbringing, Reward, Punishment, Family, Father, Mother, Responsibility, Islam, Etiquette, Son, Daughter, Age, Puberty, Adolescent.*

**INTRODUCTION**

Islam pays special attention to the education of young people. Therefore, the question of when to start educating young people is answered in Islam by choosing their mother (or father). That is before the baby is born, attention is paid to who it can be born from. The expectant mother or father is the apparent founder of child-rearing. Because a baby is born pure and is influenced by the environment in which it is raised and dies. The Messenger of Allah (peace and blessings of Allah be upon him) said:

“Every child is born like Islam (that is, in pure nature). His parents will make him either a Jew or a Christian or a pagan.”

So, in Islam, the focus on educating young people begins with choosing a bride or groom. So what to look for in this process? Let us look at the hadiths of the Messenger of Allah (peace and blessings of Allah be upon him) in this regard.

It is narrated on the authority of Abu Hurayra that the Prophet, may Allah bless him and grant him peace, said:

“A woman gets married for four things. For wealth, account, beauty, and religion. You choose your religion! Fill your hands with dust!”

Ibn Majah narrated from 'Abdullah ibn Umar that he narrated the following hadith:

“Do not marry women just for the sake of beauty, it can ruin their beauty, and do not marry for the sake of wealth, but this wealth can make them horny, but marry the believers, of course, even if they are black maids, the believers are better.”

If a parent is religious, he will raise his child to be religious. In many ways the influence of mothers on the upbringing of their children is great.

The expectant mother should also choose the future father of her child. Here, too, the religion, morals, and ethics of the future father are considered.

It is narrated on the authority of Abu Hurayra that the Prophet (peace and blessings of Allah be upon him) said:

If a man comes to you who is pleased with his conduct and religion, marry him, and if you do not give him, you will cause great corruption in the land.

Once the two religious men and women get married, the next stages of child-rearing now take place. A woman should be more careful when she is pregnant with a child.

Islam also places the responsibility of education on the upbringing of the child. Indeed, Islam itself is a religion of science and education. The first revelation addressed to the Prophet (peace and blessings of Allah be upon him) reminded him of knowledge and teaching. When teaching a child, it is necessary to teach him to read and write. Because reading and writing are the main tools of learning. At the same time, the child should be taught the sciences of his time, depending on his abilities. Because without knowledge, the power of the nation decreases. The people of the Age of Happiness, who are an example for us, we're the leaders in all areas of their time. We also need to educate our youth as Islamic pioneers. They also need to be taught other languages. Whoever knows the language of a people will be saved from their scheming. It is narrated on the authority of Zayd ibn Thabit. He said:

The Messenger of Allah (peace and blessings of Allah be upon him) said to me, 'Do you know the Syriac language? I will receive letters from them. ' I said, "No," and they said, "Learn." I learned that language in seventeen days. If a letter came from the Jews, he would read it, and if the Messenger of Allah (peace and blessings of Allah be upon him) wanted to send a letter to them, I would write it down. ' ”

It is also necessary to promote the acquisition of science from a young age. It is narrated on the authority of Abu Dawud. He said: The Messenger of Allah (peace and blessings of Allah be upon him) said: The example of one who acquires knowledge in infancy is like a pattern carved in stone. The example of one who acquires knowledge in old age is like being written in water. ' ”

Abu Umamah said, "The Messenger of Allah (peace and blessings of Allah be upon him) said, 'When a young person grows old in knowledge and worship, Allah will give him the reward of 92 sincerity on the Day of Resurrection.'

Luqman Hakim advises his sons:



“My son! Seek knowledge in your youth! Of course, it will be difficult to demand knowledge in old age. Oh, my son! Just as Pandu's advice is insane, so it is difficult for an old man to cross the pass.”

This means that the responsibility for attracting young people to science lies primarily with parents. At the same time, the child should be taught a profession. Because, as he spends his knowledge for the development of the nation, he will benefit people from the profession he has learned, and he will find honest and pure sustenance for himself. You don't need anyone.

The Prophet (peace and blessings of Allah be upon him) said: “The best food a person can eat is what he earns through his profession. Of course, the Prophet David (peace and blessings of Allah be upon him) used to eat from his own hands.”

The Messenger of Allah (peace and blessings of Allah be upon him) also said: “Among the sins are those for which only the concern for the sake of halal sustenance is expiation.”

It is obvious that in the education of young people, it is important to pay attention to their professionalism.

It is the responsibility of every parent to introduce our youth and children from infancy, first of all, to the One who created them, and to make them perfect believers, believers, serving their religion and homeland.

Good behavior is the highest and most superior of all human qualities. Because goodness is always expected from the owner of good behavior: he only benefits himself, his family, society, and the whole environment. What great words the Prophet s.a.v uttered for the youth who are the future owners of our society. The Prophet (peace and blessings of Allaah be upon him) said:

“That is, one of the most difficult things to do on the scales on the Day of Resurrection is to fear Allah and to be virtuous.”

In another hadith, they say: “O my Ummah? You can never fully thank each other with wealth and donations. Therefore, try to find your consent with openness and kindness.” (Narrated by Imam Bazzar and Bayhaqi.) [2] Teaching children good manners and Islam is better and more rewarding than supererogatory worship. For with the righteousness of children, one finds pleasure in the grave.

The charity of a good child and his good deeds make the grave of his parents full of light and the pure in spirit happy. There are ten types of good manners:

- Avoiding conflicts with people in good deeds.
- Not giving in to emotions and passions.
- Not looking for the shortcomings of others.
- Compassion for someone's unhappiness and understanding it correctly.
- If the offender confesses his guilt, forgive him.
- Assistance to the needy.
- Taking care of people.
- Be able to see their shortcomings.

- Etiquette is being moral.

- Be polite.

We need to cleanse our children of bad behavior and corrupt ideas. The Prophet (peace and blessings of Allah be upon him) said: "Just as vinegar spoils honey, so evil and immorality spoil one's deeds."

From the above, we can conclude that good manners are the first step towards the perfection of our young people. Only young people with good manners and good manners can reach the highest peaks in science and profession. May Allah bless our youth with good manners.

#### REFERENCES:

1. Bossword K.E. History of Muslim dynasties. – T.: Fan, 2007.
2. Jumaboev Y. From the history of the development of philosophy and moral thought in Uzbekistan. – T.: Oqituvchi, 1997.
3. Mirza Kenjabek. Great Termezians. – T.: Uzbekistan, 2017.
4. Hoja Ahror Valiy. Sufism and politics. – T.: Ma'rifat, 2004.
5. Ghazzoliy Abu Hamid. Kimyoi saodat. Mahkam Mahmud's translation. – T.: Adolat, 2005.
6. Ghazzoliy Abu Hamid. Mukashafatul qulub. Translated by Miraziz Azam. – T.: Adolat, 2002.
7. Ghazzoliy Abu Hamid. Ihyau Ulumud-din. Translation by Rashid Zahid. – T.: Mowarounnahr, 2006.
8. Ghazzoliy Abu Hamid. Hey, kid. Translation by Yuldash Eshbek. – T.: Mowarounnahr, 2005.

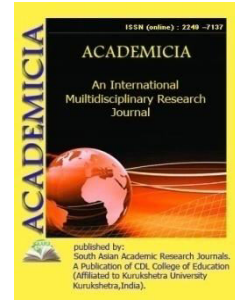
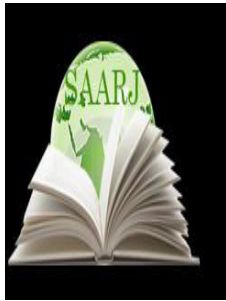

DOI: **10.5958/2249-7137.2021.01968.6**

## A TRADITION AND ARTISTIC-AESTHETIC RENEWAL - AS A FACTOR FOR THE DEVELOPMENT OF LITERATURE

**Boltayeva Iqbol Tadjibayevna\***

\*Associate Professor of Uzbek Language and Literature,  
Candidate of Philological Sciences,  
Uzbek State University of Physical Culture and Sports,  
UZBEKISTAN

### ABSTRACT

*In the article, the term "tradition" refers not to all aspects of the literary process of a particular period, but to certain events in it, more often in the past, features that were accepted by many in the examples of the literary process in later periods. due to the fact that it is adapted to the requirements of the time with some changes and additions, and sometimes it is applied exactly without any changes and additions, the tradition also follows the law of uniqueness in repetition, resulting in literary succession. The article can be used by philologists dealing with various issues of fiction and a wide range of readers interested in art.*

**KEYWORDS:** *Uzbek Literature, Uzbek Classical Literature, Alisher Navoi, Zahiriddin Muhammad Babur, The Future, Repetition, Literary Tradition, Ghazal, Rubai, Tradition, Cognitive Process.*

### INTRODUCTION

Due to the constant change of seasons in nature, day and night, the constant movement of life, the progressive flow of time can be seen. Although the years, seasons, months, days, and nights in which change is regular and inevitable seem to be repeated in an invariant uniformity on the surface, in reality each of them, on its own scale, the whole being, is definite. has a unique significance in the lives of society and individuals.

In the midst of a time that seems to repeat itself in a regular and unchanging way, someone is born, grows up, studies, achieves a goal, starts a family, has children, works. , holds events, dies, and so on. Such events, which are crucial for a particular person, constitute unique stages in the life of every person who lives in the midst of constant repetition. This uniqueness leads to changes in the uniform flow of existence in the repetitive shell of existence, and corrections

sometimes lead to complete reconstruction and renewal. So, the philosophical essence of life, the flow and development of being, is due to the harmony of repetition and the uniqueness that is born in it.

This theoretical issue has not yet been specifically studied in Uzbek literary criticism. This monograph provides an example of the dialectic of repetition and uniqueness.

Rubai in classical Uzbek poetry is a lyrical genre with an independent form of four lines. It is a poetic genre in which the Hajj Sea of Aruz weight must be written in only two genealogies, each consisting of twelve branches, such as ahrab and ahram. It is well known that every poet who claims to write in the rubai genre has to obey the students. If he does not comply with these requirements, his work will not be considered a rubai. Therefore, all Rubaiyat poets can be considered Rubaiyat only if they repeat the requirements of this law in their works. At the same time, every original rubai created by different artists must be unique in its content, images and artistic expression.

In general, literary succession occurs because tradition also follows the law of uniqueness in repetition. This law is the result of certain traditions in the literary process and their innovative (innovative) application. The most difficult part of this problem is to understand that the literary process, along with the phenomenon of tradition and all other factors outside it, is repetitive, and that the uniqueness of repetition ensures the gradual continuity of literary succession.<sup>1</sup>

"Education of our national mentality, respect for the traditions and customs of the people through the delivery of the unique artistic freshness of Uzbek literature on the basis of Uzbek classical literature to students is the basis of our national education," Alisher Navoi said. He was not only a great poet, a great statesman, a thinker, a philosopher, a literary critic, a linguist, a historian, and even a scholar of music. "

Hazrat Navoi made a unique poetic discovery in the experience of artistic creation while depicting the external beauty of his mistress based on the use of words in the famous rubai, which begins with "Silence of my soul ...", using the appearance of letters in the Arabic alphabet.:

Jonimdog'i "jim" ikki "dol"ingg'a fido,  
Andin so'ng "alif" toza niholingg'a fido.  
"Nun" dog'i anbarin hilolingg'a fido,  
Qolg'on ikki nuqta ikki xolingg'a fido.

In a poem written in one branch of the same genre, Babur expresses the irreversible image of a lover who has not reached the heights of his beloved, based on a thousand-year-old tradition, as follows:

Jismimda isitma kunda mahkam bo'latur,  
Ko'zidin uchatur uyqu chu axsham bo'latur.  
Har ikkalasi g'amim bilan sabrimdek,  
Borg'on sari bul ortatur, ul kam bo'latur.

In this branch of the same genre, the modern Uzbek poet Jamol Kamol, in accordance with all the requirements of the rubai, expresses the confused mood and mood of our contemporary - a man of the twenty-first century, who is struggling to recognize himself. tries to:

Ko'nglim sari ko'p sirqima, yosh, tomchilama,

Yosh bo'ldi bu ko'ksimdagi tosh, tomchilama.

Sabrim tugadi, bo'ldi odosh, tomchilama,

Zulmat chekinib, chiqdi quyosh, tomchilama.

According to Professor A. Hayitmetov, Alisher Navoi wrote 133 rubai in Uzbek and 73 rubai in Persian. This means that the great thinker repeated himself two hundred and six times in his 206 rubai. But none of these 206 rubai actually returned the other in terms of content or expression. Also, if Bobur's collection, prepared by the scientist E. Ochilov and published in 2007 as "Sochi's trade fell", contains 209 rubai, the poet in their creation is two hundred and nine times repetitive in terms of genre canons, creative intent and its expression. 'I had to put. However, if we look at the ideological and artistic features and content of the rubai, it seems that each rubai was created as a unique literary phenomenon that does not repeat each other. This means that Babur, as the inheritor of the rubai tradition, created two hundred and nine unique literary works based on two hundred and nine repetitions. Jamal Kamal's book "The Burning Field" contains 113 rubles. Apparently, the poet relied on one hundred and thirteen repetitions to create a unique work.

So, what determines the uniqueness of lyrical images in ghazal poets? Or does the poem have to be unique? By what criteria is the artistic level of a ghazal measured? It is natural that a number of such questions arise.

In fact, the uniqueness of the lyrical image is just as important in the ghazal genre as the uniqueness of the image in general. It is noteworthy that the Eastern ghazalism, from the distant past to the present, has also ensured the high development of classical lyricism, in accordance with the law of repetition. The question arises: how could poets achieve uniqueness in the context of defined patterns, lyrical images that must be present each time? Real talents can be found in new situations and spaces, in a new mood, in a new mood, without completely replacing the existing lyrical images, such as a stable form, a lover, a mistress, a rival, a flower and a nightingale, with completely different forms and images. through the show they went on the path of poetic discovery of completely new aspects of traditional emblems. The ability to achieve uniqueness in repetition is one of the most unique, greatest and most powerful manifestations of Eastern lyricism, especially in ghazal poetry. As Garcia Lorca once rightly pointed out, not only the creation of a new image, but also the discovery of other features of the existing image, new aspects of its nature, is an important means of creating an artistic image.<sup>2</sup>

As the saying goes, a true work of art exists in a unique whole. And again, these would mean that you have to spend for these processes. After all, a situation that requires constant repetition encourages the talented person to get out of the clutches of these repetitions. What makes such a repetition of a true work of art?

Upon closer inspection, it can be seen that this kind of recurrence occurs in several cases. First, the fact that any artist depicts a genre, or a theme, or a person, or exactly the same events in the

presence of the same images is an important factor that creates repetition. For example, in modern Uzbek literature there are several works dedicated to the life of Alisher Navoi. Oybek's novel "Navoi", epics "Navoi" and "Guli and Navoi", the story "Bola Alisher"; Alisher Navoi drama by Uygun and Izzat Sultans; Lydia Bat's short story "Boston of Life", B. Boykobilov's four-volume poetry novel "Troubled Khorasan", "Glorious Caravan", "Silent Khorasan" and "Bloody Khorasan", Omon Mukhtor's "Navoi and the Artist" The novel-dilogy "Abulkhair", the drama "Amir Alisher's pain" and many other works are dedicated to the life and work of the great thinker Alisher Navoi. These works are unique in that they are written about the life of a single historical figure, the time and place in which he lived and worked. However, these repetitive aspects, such as the level of artistic and historical coverage of each artist, the way of artistic research, analysis and interpretation, the genres to which they refer, the methods of using existing information, are not repeated in every work on this subject. allowed to create uniqueness.

Second, even if each artist's well-written work is created as a unique product, any writer or poet in his or her creation is doomed to shake the pen, nourished by the creative experiences of many unique artists. For example, when creating a novel or epic about Oybek Navoi, it is impossible not to use the experience and traditions of the novel or epic, the requirements and opportunities of this genre. It is also clear that Alisher Navoi studied scientific, historical and artistic writings. It seems that uniqueness in the repetition that ensures the succession in the literature is a stable law that applies in each national literature, in each of its stages, in the work of each representative, with its own scope, its own scale.

Indeed, the creator must be able to look at reality in terms of genre possibilities when creating any work. It is in the process of this view that he reconstructs the content of reality, its essence, in an order that meets the requirements of the genre, using intuition. This reconstruction of the creative process allows the artist to create a new idea, a unique artistic image. This possibility is due to the fact that the genre is defined by repeated requirements that have been repeatedly tested in the creative process. This means that the development of literature is ensured by the fact that the uniqueness that arises from repetition occurs in the same repetition.

It is clear that the uniqueness of repetition, that is, the essence of innovation, is crucial for the development of any national literature. In scientific sources on Uzbek literature, the term "innovation" is still used to refer to the uniqueness that appears on the basis of repetition. In the current context of growing national identity and fiction being the most influential tool in the process of identity recognition, we felt it appropriate to call this phenomenon "innovation".

When it comes to the existence of uniqueness in repetition, the question arises as to which of them is more important for literature and the study of literature. This question can only be answered in the light of the nature of fiction. In essence, both science and art, including fiction, study the objective being and man. For example, the science of history studies the history of the path that humanity has traversed and traversed during its development, while art and literature study the life of an individual who is a traveler on that historical path. li, an artistic study of the spiritual world, emotions, joys and sorrows.<sup>3</sup>

While art and fiction are encouraged to portray the life, destiny, feelings, and thoughts of an individual, it naturally sees it as a primary task to portray the unique aspects of a person. It is natural, therefore, that in art and literature it is more important and costly for an artist to achieve



a unique individuality by deviating from them than by following the general laws. According to LN Tolstoy, "In describing the historical period, the historian and the artist have two distinct and at the same time interrelated aspects. If the historian is wrong in describing the historical personality in its entirety and in its complex relationship to all aspects of life, then the artist who tries to reveal its historical essence cannot do his job."<sup>4</sup> - It should be noted that the idea that.

We will try to express our opinion more clearly with the help of examples from the history of Uzbek literature. It is known that between Alisher Navoi and Babur rubai there are many works that are very similar or very close in terms of themes and ideas. But no matter how similar and close the theme and artistic intention are, the rubai of these two great artists are completely unique. For example, in the following famous rubai of Alisher Navoi, the grief of a stranger in exile, the strangeness of joy to him, the absence of a compassionate and kind person for such a person, even though he is richer and poorer than living freely. It is sung in a way that any poet will never forget:

G'urbatda g'arib shodmon bo'lmas emish,  
El anga shafiqu mehribon bo'lmas emish.  
Oltun qafas ichra gar qizil gul bitsa,  
Bulbulg'a tikondek oshyon bo'lmas emish<sup>5</sup>.

In the lower rubai of the king and the poet Babur, as in the poem of Hazrat Navoi, it is expressed that no one remembers a stranger, does not try to make him happy, and a stranger does not know what joy is:

Yod etmas emish kishini g'urbatta kishi,  
Shod etmas emish ko'ngulni mehnatta kishi.  
Ko'nglum bu g'ariblikda shod o'lmadi, oh,  
G'urbatta sevunmas ermish, albatta, kishi<sup>6</sup>.

The rubai quoted from the works of both poets are written on the same theme, in the same genre, and even in the same weight as the ahrab tree of the Hajj sea. The aspects enumerated now constitute the repetition in these writings. But it is clear that it is impossible to say that these two works are the same, after reading one and not reading the other. Each artist's unique artistic interpretation of the subject makes them unique writings.

A similar situation can be seen in the works of artists of completely different periods, both in terms of time of creation and in terms of the principles of artistic approach to life. Hazrat Alisher Navoi in his work "Mezon ul-avzon" writes about the genre of tuyuk, which is used only in Turkish poetry: The goal is to:(tuyug')

Yo rab, ul shahdu shakar yo labdurur?  
Yo magar shahdu shakar yo labdurur?  
***Foilotun foilotun foilon***  
Jonima payvasta novak otqali  
G'amza o'qin qoshig'a yolabdurur?

*Foilotun foilotun foilon<sup>7</sup>*

Some time after the great thinker, in the epic "Ravshan" sung by Ergash Jumanbulbul, a poem with a completely different meaning from the language of Hasankhan, written in a completely different context, was written in the same genre of ostrich. Because the poem in the epic meets the requirements of the genre of ostrich, described by Hazrat Navoi, in many respects. It is true that the hen used in the epic is not in the form of a dream, but in the finger system, which is traditional for Uzbek folklore. Consequently, the frame frame does not fall at the target weight at all. But the hen in the folk epic, like Navoi's work, has eleven syllables, in which the word tajnis, which has different meanings, has served as a rhyme:

Qo'lingdan kelgancha chiqar yaxshi ot,  
 Yaxshilik qil, bolam, yomonlikni ot!  
 Nasihatim yod qilib ol, yolg'izim,  
 Yolg'iz yursa, chang chiqarmas, yaxshi ot.

It seems that neither time nor space can prevent the fulfillment of the basic requirements that determine the nature of a literary genre. At the same time, the two hens have nothing in common but similarities in shape. This means that in art, the unique personality of the artist, his unique talent, the individuality of his worldview, and the uniqueness that arises due to the life and mood of the artist are depicted.

**REFERENCES:**

1. Alisher Navoi. A perfect collection of works. Twenty volumes. Volume 16 –T.: "Fan", 2000. Pages 71-72.
2. Alisher Navoi. MAT. Volume 3 –T.: 1994. P. 573.
3. Zahiriddin Muhammad Bobur. Devon. –T.: 1994. B. 96.
4. Kazakhboy Yuldosh. The word flame. –T.: Ghafur Ghulam NMIU, 2018.
5. Boltayeva I. The problem of succession in literature. Monograph. "Editor's Publishing House". 2020 p.21.
6. Boltayeva I. T., Musayev I.S., Rakhimova M. A. Literary success -a product of combination with confirmation and denia // Journal of American Studies, 84 (2021), 4, 1816-1825
7. Boltayeva I.T., Ayxodjayeva M.S. Uzbek language. Study guide. Lesson Press LLC Publishing House. Tashkent, 2020, p.72.
8. 8.Bushmin A. S.Preemstvennost' v razvitii literatury.- Leningrad: 1978, c.131-160;
9. 9.Barabash Yu. Ya. O povtoryayushemsya i nepovtorimom. Sovremennye problemy literaturovedeniya i yazykoznaniya. -Moscow: 1974. p.65-93.
10. 10.N.G. Chernishevskiy. Sobr.soch.v pyati tomax. t. 4. -Moscow: 1974. p.112.

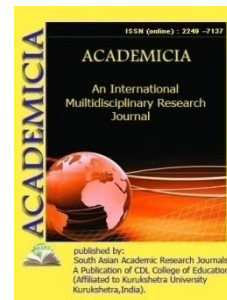

DOI: **10.5958/2249-7137.2021.01969.8**

## NEW PRODUCING WAY FOR KNITTED FABRIC WITH HIGH HEAT SHIELDING PROPERT

G.Kh. Gulyaeva\*, M.M. Mukimov\*

\*Tashkent Institute of Textile and Light Industry,  
Tashkent, UZBEKISTAN

### ABSTRACT

*The article is devoted to the development of a method for increasing the heat shielding property of knitwear. The goal achieved due to presence of laid and fleece threads in the developed structure of knitwear. Besides this way allows obtaining double-sided colored knitted fabric. This effect is present on both sides of the knitted fabric, as the indexes of the laid thread outline on both sides of the jersey are the same.*

**KEYWORDS:** *Knitted Fabric, Laid Thread, Fleecy Thread, Heat Shielding Property, Double Knitted Machine.*

### INTRODUCTION

Knitted fabrics are formed by knitting threads. The loop is the main link in the structure of the fabric, its ability to change shape and size in all directions provides extensibility - this is how knitted materials differ from all others. Knitwear is a material with amazing properties: it warms in the cold and cools in the heat.

Due to the loop structure, air circulates, which is why it is so pleasant to the body - in the summer it is heat, the skin breathes, in winter, knitwear protects the body from heat exchange with cold air.

Currently, there is a boom in the use of knitted fabrics in almost all areas of human life: in technology, medicine (development of new synthetic knitted materials to restore the anatomical forms and functions of human internal organs), construction, auto and aircraft construction, shipbuilding, rocket and space technology, geotextile and many others.

New methods of processing in the technological process expand the field of application of knitwear. It has become widely used for the manufacture of protective materials in industry, work wear items, for example, knitted gloves with a special coating. Nylon threads increase

strength, wear resistance, due to the looped structure, the back of the hand is ventilated, which ensures comfort when working for a long time, and the latex coating on the palm side and fingers increases adhesion, tear and abrasion resistance when interacting with an aggressive environment, construction materials. These gloves are great for auto repair, construction, handling. It is equally convenient to lay metal roofing tiles in them and to work in the garden.

## **MATERIALS AND METHODS**

The development of knitwear production is due to the increasing demand for knitwear every day, since they are hygienic, have a beautiful appearance, as well as high performance characteristics. To expand the range of knitted outerwear, as well as improve the quality of manufactured knitwear, it is necessary to use new types of raw materials, apply new structures and methods of producing knitwear with improved hygienic properties, high dimensional stability [1-4]. In the conditions of the actively developing integration of science and industry, when scientific developments are aimed at improving product quality and increasing production efficiency, it is especially important to develop new types of knitwear with high consumer properties and methods of their production that can be introduced into knitted production enterprises without additional costs and reconstruction of the equipment. One of the most widely used weaves in the production of knitwear is lined.

Known double inlay jersey [4], obtained on the basis of rib stitch. This jersey contains a ground thread, the tucks of which in all the loop wales have been knitted together with the old ones on the new ones. In this case, the laid thread is fixed in the ground by platinum broaches of one row of ground knitwear.

The disadvantages of this knitted fabric are the low degree of fixing of the laid thread in the structure of the knitted fabric, as well as the complexity of the process of its production. In work [5], a method is proposed, where double knitted fabric of inlay stitches contains plain loops formed by incomplete rib stitch and broaches of a laid thread, while the laid thread is fixed in the ground by platinum broaches of loops of several rows of ground knitwear. In the proposed method for the production of lined knitwear, a lining thread, laid on half of the needles of both needle beds, makes it possible to obtain double-sided colored cells on the fabric. This effect is located on both sides of the jersey, as the indexes of the lining thread outline on both sides of the jersey are the same. This makes it possible to reduce material consumption, increase air permeability and improve the hygienic properties of the double lined fabric. Since the laid thread wraps around a large number of ground loop broaches, the degree of its fixation in the structure increases. Broaches, located along the looped wales in several looped rows, reduces the stretch of the knitted fabric along the length. The disadvantage of this method for the production of inlay knitwear is that the large extensibility of the knitwear in width reduces its dimensional stability. In this research work a method for the production of knitted fabrics with a reduced elasticity in width and an increase in its dimensional stability, and also heat shielding properties was developed.

The problem is solved by the fact that the double knitted fabric of inlay stitch contains plain loops formed by an incomplete rib stitch and tucks of a laid thread, while the laid thread is fixed in the ground by broaches of loops of several rows of ground knitwear, the knitted fabric in each rib row contains a laid thread, which located between the loops of the needles of the cylinder and disk [6].

In fig. 1 shows the developed structure of form-stable knitwear, and fig. 2 - the process of obtaining it on a circle double knitting machine. As can be seen from Fig. 1, jersey is knitted on the basis of rib stitch. The ground for knitwear is produced from thread G. The front loops of knitwear with purl loops are connected by broaches Pr. The front N1 and the purl N2 tucks from the laid thread F, laid in the first row, are fastened in the knitted fabric with the tuck broaches. In this case, the lining thread is fixed in the ground by broaches of loops of several rows of ground knitwear. The inserted U laid is between the knit and purl stitches of each row of the rib and the broaches. Form-resistant knitwear on a double knitting machine is produced as follows (Fig. 2). The machine uses an interlock arrangement of needles. In the first system, the lining thread is inserted on half of the needles of the first and second beds, that is, on needles 2, 3. In the second, third and fourth systems, the second half of the needles of both beds, that is, needles 1, 4, etc., knit an elastic row (II, III and IV rows). In the fifth system, the tucks N1, located on the needle of the cylinder 3, is transferred to the purl loop located on the needle of the disc 4. Accordingly, the purl N2, located on the needle of the disc 2, is transferred to the front loop located on the needle of the cylinder 1.

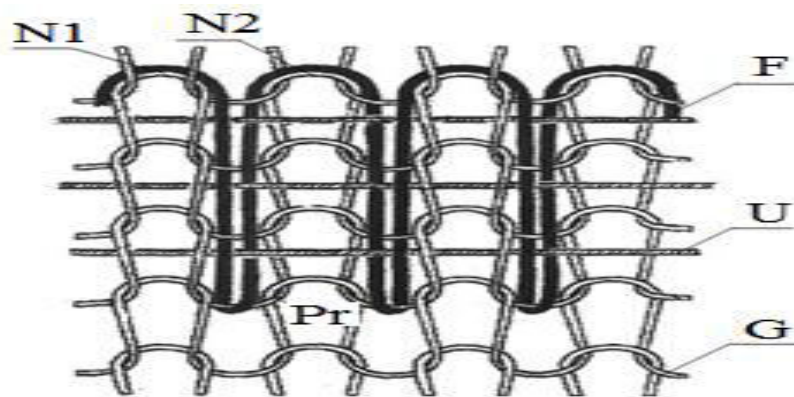

Fig 1. Structure of fleecy-inlay knitwear

In these systems, a laid thread U is inserted between the needles of the cylinder and the disc using an additional thread guide. Broaches Pr, which connect the front loops with the purl loops of the rib, are located between the tucks N1 and N2 of the laid thread F. In the fifth system, the tucks N1, located on the needle of the cylinder 3, is transferred to the purl loop located on the needle of the disc 4. Accordingly, the purl N2, located on the needle of the disc 2, is transferred to the front loop located on the needle of the cylinder 1.

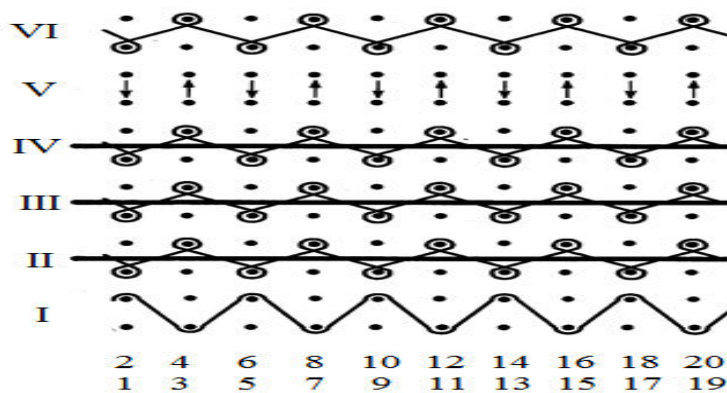

Fig. 2. Graphical record of the process of obtaining fleecy inlay knitwear

In the sixth system (VI-loop row), the needles of the cylinder 1, 3, 5, etc. and disc needles 2, 4, 6, etc. knit an elastic row consisting of front and back loops. In this system, drafts H1 and H2 are dropped onto the Stretch weave broaches.

The presence in the knitted fabric structure of a lining thread, laid on half of the needles of both beds and connected to the ground weave of the jersey, worked out on the other half of the needles of both beds, and a weft thread inserted between the needles of the cylinder and the disk and located along the loop row reduce the extensibility of the jersey in length and width, therefore, the dimensional stability of the knitted fabric is increased. Six loop-forming systems are required to form one repeat. To produce this knitted fabric, it is enough to install additional yarn guides for laying the laid and fleecy yarns. Due to the development of fleecy-inlay knitwear of the proposed structure, the technological capabilities of the circular double knitting machine are expanded.

The presence of laid and fleecy threads in the structure of knitted fabric allows to obtain double-sided colored cells on the fabric. This effect is located on both sides of the jersey, as the indexes of the lining thread outline on both sides of the jersey are the same. The resulting jersey can be successfully used for knitwear of the upper and children's assortment.

## REFERENCES

1. M.M. Mukimov. Knitwear of special properties, formation, structure. People's word. Release March 26, 2016 Tashkent.
2. Gulyaeva G.Kh. Improving the hygienic properties and increasing the dimensional stability of knitwear by changing the structure of the knitwear and using lycra thread. Dis .... for a job. learned. step. PhD. TITLP. Tashkent. 2018
3. Gulyaeva G., Mukimov M. Method of improving hygienic properties of formstable knitted fabrics. International III Forum of innovative ideas, technologies and projects -2017. May 10-12, 2017 Tashkent. -S. 110-116.
4. S.A. Frydrych I., Dziworska G., Bilaska J., Comparative Analysis of the Thermal Insulation Properties of Fabrics Made of Natural and Man-Made CelluloseFibres. Fibers & Textiles in Eastern Europe, October-December, 40 (2002).
5. Kudryavin L.A., Shalov I.I. Fundamentals of knitwear production technology. M .: Legprombytizdat. 1991 -with. 374-375.
6. Patent No. 2244052 (RU) Cl. D04 B21 / 14. Double jersey. E.N. Kolesnikova, A. Yu. Galaktionova, O.P. Fomin. Publ. 10.01.2005
7. Patent UZ IAP No. 06330. A method for producing form-stable knitwear. Gulyaeva G.Kh., Kholikov K.M., Khamidova D.U., Mirsadikov M.M., Musaeva M.M., Mukimov M.M. Publ. 11/30/2020 Bul. No. 11.



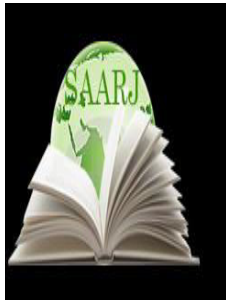

**ACADEMICIA**  
**An International**  
**Multidisciplinary**  
**Research Journal**  
 (Double Blind Refereed & Peer Reviewed Journal)

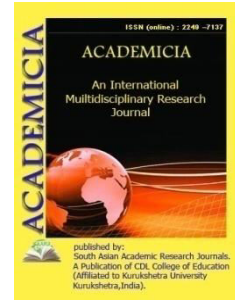

**DOI: 10.5958/2249-7137.2021.01970.4**

**ABOUT BURYNING SOIL IN FERGANA (EXAMPLE: THE HILL OF SARIQORGON IN UCHKO'PRIK DISTRICT)**

**Artiqova Gozalxon girls Nosirjon\*; Zakirova Sanoat Khomdomovna\*\*;  
 Axmedova Dilfuzaxon\*\*\***

\*The museum of Fergana Region History and,  
 Culture state manager of Sector,  
 UZBEKISTAN

\*\*Researcher and Professor,  
 Ferghana State University, UZBEKISTAN

\*\*\*Researcher and Dotsent at Ferghana State University,  
 UZBEKISTAN

**ABSTRACT**

*The main meaning is to learn the hill of Sariqo'rgon buryning soil how to appear this soil and learning their properties and their structure. Likewise; historical fort how to appear during many century and learned it's task.*

**KEYWORDS:** *Sariqo'rgon, So'x, Buryning Soil, Geomorphology, Valley, Relief, Braveries, Hills, Biologik, Etmografic, Mountain, Nature , Practice.*

**INTRODUCTION**

Fergana region is situated in the high mountains and geographic canyon. The heighest mountains and central plain, height relief we can meet in this area and they are divided two : the first is mountain draft and the second is knoll relations . The south of Fergana region is separated parallel plain and is met three draft and among these plains have kneels , these are hardly ever met constant water flow . The river which flows the south and streams carry out about knoll and appeared valleys . This information was given by N.P .Vasilkovskiy (in 1937) the older mountains draftes are not height .

V.N.Veber described : "the south of valley and mountain of rivers come from plain spaces is the last assembly solid area ". And he gived name them " Jabber Delt " the fourth epoch konglomerag outwards are separated from Konibodom to Fergana of knolls the top and low areas

.He registered the fourth epoch is begun these area . The south of rivers (Isfara ,So'g'd ) carry out from mountains area put konglomerag outwards the dry Delta in 1929- 1930.

The Fergana region is relief very difficult and this geological structure situated is among , mountains is appeared carrying out very difficult. The geomorphology is main intention of Sario'rgon burying soil geomorphology valley relief braveries hills biological ethnographic mountain nature and science fair project. This area is learned many scientific researchers these are O Shevchenko, N,N Putinsev ,A,D Radokovskiy and others .Our main meaning to learn how life is to appear this complex. The hill has seven grave . And this grave belong to stone ages,antic century and people lived in this area. The geomorphology is main meaning to ask some questions about knoll relations between . Sario'rgon burying soil was learned, chaked , in 2014 .20.05 . State of culture organization.

### **USED LITERATURE**

1. Latinin dnevnik "Ferganiskiy oblasti ekspeditsiya" 1973.
2. Middendorf " Ocherki Ferganiskiy dolina" in 1880.
3. Petrof A.D " Razvaline Mugtepa u seliniye Sario'rgon".
4. Q24.G Yo'ldoshev .X Zakirova ,M.Isagaliyeva "Orashemex zemelny fond Ferganiskiy fond".

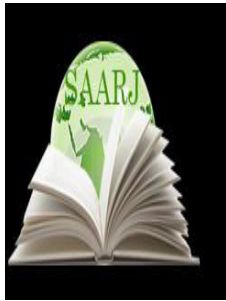

**ACADEMICIA**  
**An International  
Multidisciplinary  
Research Journal**  
(Double Blind Refereed & Peer Reviewed Journal)

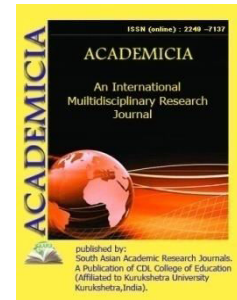

**DOI: 10.5958/2249-7137.2021.01975.3**

## **TOKYO OLYMPICS AND PERFORMANCE OF INDIAN ATHLETES IN MULTIPLE SPORTS TOURNAMENTS**

**Dr. Anjana Lohan\***

\*Associate Professor,  
Head, Deptt. of Physical Education,  
S.D. Mahila Mahavidyalay, Narwana ( Jind), INDIA

### **ABSTRACT**

*The Tokyo 2020 Olympics, the world's largest athletic event, came to a close on Sunday, August 8th. In light of the recent COVID-19 outbreak, the Tokyo Olympics have been postponed until 2021 from its planned date of completion last year. It was the largest-ever delegation from the Indian Olympic Association (IOA) that travelled to Tokyo for the games. It was envisioned that India will become a major sports power. The sportsmen proved that they aren't afraid to go all the way to the top in order to achieve their goals. "A journey of a thousand miles" is said to begin with "a single step," and that was the first step taken by our 126-person team as well. India's best-ever Olympics in Tokyo 2020 have injected a new spirit and optimism in the country's sports community with 7 medals (one gold, two silver, and four bronze) and a number of close finishes.*

**KEYWORDS:** *India In Olympics, Tokyo Olympics, India's Performance In Sports*

### **INTRODUCTION**

The medal count for Team India began on Day 1 with a silver medal for weightlifting's women's 49kg division winner Mirabai Chanu. After PV Sindhu, the Manipur-born athlete earned India's second Olympic silver medalist (2016 Rio). She is also the second weightlifter from India to win an Olympic gold, after Karnam Malleswari (2000 Sydney).

India's top medal contender, Pusarla Venkata Sindhu, delivered on her expectations. PV Sindhu, the current BWF World Champion, finished third in Tokyo 2020. The 7th-seeded badminton player is just the second Indian to win two Olympic medals, after Sushil Kumar (2008 and 2012).

At the Tokyo Olympics, India picked up a third medal thanks to Lovlina Borgohain. In her debut Olympiad, the Assamese-born athlete came away with a medal. As a result, she joined Vijender Singh and MC Mary Kom as the only Indian boxers to earn an Olympic gold.

**TABLE 1 : INDIA'S PERFORMANCE IN ASSORTED TOURNAMENTS**

Name	Medal	Event	Sport	Date
Neeraj Chopra	1 Gold	Men's javelin throw	Athletics	7 August
Saikhom Mirabai Chanu	2 Silver	Women's 49 kg	Weightlifting	24 July
Ravi Kumar Dahiya	2 Silver	Men's freestyle 57 kg	Wrestling	5 August
P. V. Sindhu	3 Bronze	Women's singles	Badminton	1 August
Lovlina Borgohain	3 Bronze	Women's welterweight	Boxing	4 August
India men's national field hockey team <ul style="list-style-type: none"> <li>• Dilpreet Singh</li> <li>• Rupinder Pal Singh</li> <li>• Surender Kumar</li> <li>• Manpreet Singh (C)</li> <li>• Hardik Singh</li> <li>• Gurjant Singh</li> <li>• Simranjeet Singh</li> <li>• Mandeep Singh</li> <li>• Harmanpreet Singh</li> <li>• Lalit Upadhyay</li> <li>• P. R. Sreejesh</li> <li>• Sumit</li> <li>• Nilakanta Sharma</li> <li>• Shamsher Singh</li> <li>• Varun Kumar</li> <li>• Birendra Lakra</li> <li>• Amit Rohidas</li> <li>• Vivek Prasad</li> </ul>	3 Bronze	Men's tournament	Field hockey	5 August
Bajrang Punia	3 Bronze	Men's freestyle 65 kg	Wrestling	7 August

After 41 years, India's men's hockey team defeated Germany and took home the bronze medal. Even now, India still leads the world in Olympic field hockey medals won. This victory has given new life to an age-old Indian pastime.

India's fifth medal was earned by wrestler Ravi Kumar Dahiya. The Harayan-born 23-year-old made one of the most impressive comebacks in men's 57kg freestyle wrestling history. He was the second Indian wrestler to earn an Olympic silver medal, after Sushil Kumar (2012 London).

Bajrang Punia's bronze medal in men's 65kg freestyle wrestling matched India's greatest Olympic result, increasing the country's medal total to six. The wrestler who will carry India's flag in the closing ceremony of the 2020 Summer Olympics is the sixth wrestler from India to win an Olympic medal.

Not to be outdone, Neeraj Chopra won the Olympic Gold Medal on the last day of competition for India. In the Javelin Throw, the 23-year-old became the first Indian woman to win an Olympic gold medal in track and field, the original form of Athletics. His gold in Shooting makes him Team India's second ever individual Olympian following Abhinav Bindra's in 2008 Beijing. India won seven medals in total with a personal best javelin throw of 87.58 metres (300 feet). This man has inspired hope in 1.3 billion people across the world.



Figure 1 : Neeraj Chopra, The Gold Medalist

For India, the Olympics in Tokyo were filled with highs and lows, as well as conflicting emotions. Optimists predicted that India would bring home a record-breaking number of double-digit medals at the Olympics in Tokyo, but it only managed to bring home seven. Despite having a population of over 1.2 billion people, India has a poor track record of winning Olympic medals. No city, including Tokyo, was exempt from this rule. Investigate some of the causes behind this.

Aquatics, Athletics, and Cycling took home 49, 48, and 22 gold medals each in the Tokyo Olympics, yet the infrastructure for these three sports is in terrible shape. In addition, participation in these sports is very low. The Tokyo Olympics included a total of 33 sports, with India taking part in only 20 of them. In 33% of sports, we're not even trying to win.





Figure 2 : Indian Sportspersons at Olympics

India's delegation to the Tokyo 2020 Olympic Games set a new record, exceeding that of the previous Olympics in Rio de Janeiro in 2016. There were originally 119 competitors in the delegation, but late additions Sumit Nagal (tennis) and Diksha Dagar (golf) boosted that number to 121 according to the International Olympic Committee.

Notably, a maximum of 16 players were permitted for a hockey match, but Indian teams additionally employed two players from their reserves, and the competition included 18 players in all.. Some of the initial 119 members of the athletics team did not compete in any of the relay events. As a result, there are about 120 people who have represented India in different events.

The Games got off to a strong start for India, with weightlifter Mirabai Chanu taking home silver on the opening day of competition, and wrestler Bajrang Punia and javelin thrower Neeraj Chopra (both with a gold) closing out the competition and helping the nation surpass its previous medal total.

Medal winners will be remembered for a long time, but all athletes who competed in the Olympics should be recognised and their accomplishments documented. People often say that going to the Olympics is a huge accomplishment, and that is particularly true if the Games are in a year like 2021. Pandemic delays posed unique challenges for all athletes who participated in the Games.

The historic gold medal won by India's Neeraj Chopra in the men's javelin event on Saturday in Tokyo brought an end to the country's remarkable Olympic run.

It was India's first gold medal in a track and field event since independence from the United Kingdom, and it helped cement the country's best-ever showing at the Games, with a total of seven medals earned.





Figure 3 : India in Olympics

An airport crowd greeted Chopra as he touched down in New Delhi, India's capital, on Monday afternoon, eager to see their new national hero. Large crowd videos around the athlete have come to represent what China's second-largest population's triumph means for the globe.

The Chief Minister of Haryana, where Chopra comes from, told reporters at a press conference on Saturday that "the Haryana lad has made his imprint."

The record medal haul for India comes at a time when the country is still recovering from the second wave of the coronavirus epidemic that devastated the country. According to Johns Hopkins University statistics, the nation has seen more than 428,000 Covid-19 fatalities and over 32 million infections, putting institutions at risk of closure and taxing the healthcare system to breaking point.

Neeraj Chopra's gold medal in the men's javelin throw on the final day of the Tokyo Olympics brought an end to India's Olympic campaign. It was the first athletics medal for independent India, and it was a gold one at that. When Neeraj threw the spear in Tokyo's Olympic Stadium, India had saved its best for last, solidifying his position in the country's sports history. Indian athletes finished the Tokyo Olympics with a total of seven medals: one gold, two silver, and four bronze. To top it all off, India won more medals in Tokyo than it did in London in 2012.

In the archery competition, India had a slew of medal hopefuls, but the archery team fell short and had to return home India empty-handed. The Indian archery team faced off against Korea in the quarterfinals of the mixed archery competition. India was humiliated by a 2-6 result. They

would have at least earned a Bronze medal with a victory here. When it came to the women's archery event, Deepika was swept by world record holder An San, who was the #1 seed. Against Takaharu Furukawa, Atanu Das lost 6-4 in the men's individual round of 16. India's men's archery team was eliminated after a 2-6 defeat against Korea in the quarterfinals. In a contest, archer Atanu Das beat a Korean with ease. In addition to his two Olympic gold medals, Oh Jin-Hyek has four World Championship golds, three World Cup titles, and two Asian Games golds under his belt!

A new Asian record was established by India's men's 4x400-meter relay team. Amoj Jacob, Noah Nirmal Tom, Muhammad Anas, and Arokia Rajiv finished fourth in Group B with a time of 3:00.25. Instead of being in the finals, India was eliminated from the competition after finishing ninth in their heat. Only the next two teams in each Heat advance to the next round. While playing badminton, Satwik Sairaj Rankireddy and Chirag Shetty battled valiantly to defeat Taiwan's Lee Yang and Wang Chin-lin, the eventual gold medalists, but ultimately failed to go further in the competition.

India brought the biggest table tennis delegation in history to Tokyo, with two players participating in men's and women's singles and a mixed doubles team. Manika was the first Indian woman to win two singles matches and go to the Round of 32 in the Olympics. To advance to the R64, Sutirtha Mukherjee defeated her higher-ranked Swedish opponent from a 3-1 deficit. This is the first time in Olympic history that both female Indian paddlers have won a match. Against eventual gold medalist MA Long of China in the round of 32 of the men's singles competition, Sharath Kamal of India beat Tiago Apolonia. Tennis player Sumit Nagal surprised top-ranked Denis Istomin by entering late, while sailing and equestrian saw India compete for the first time.

## CONCLUSION

As the Tokyo Olympics come to a close, it's a good time to take stock. In the lead-up to the Games, many Indians anticipated that this would be India's greatest ever Olympics in terms of medal haul. In terms of medals, the 2012 London Olympics were our most successful to date. We came home with six gold, two silver, and four bronze. We had previously won six medals, but this time we were able to beat that total. In contrast, India saved its finest performance until last. Neeraj Chopra and Bajrang Punia added two more medals to India's five-medal haul on the final day of the world tournament.

India's 21-year medal drought in weightlifting came to an end when Mirabai Chanu won silver in the 49kg division at the Olympics. With 202 kilos of total weight lifted (87 kilogrammes + 115 kilogrammes), the 26-year-old broke Olympic bronze medalist Karnam Malleswari's record. With a mix of hope, sorrow, nostalgia, glory, and near-misses between Chanu's silver and Chopra's gold, this film is sure to inspire at least some Indians, if not the whole population. This 124-member team included world champions, world cup winners, world no. 1s, rising stars, and debutants in sports that most of India had never heard of.

**REFERENCES**

1. "Tokyo Olympics 2020: Neeraj Chopra wins historic Gold in javelin throw, India's first athletics medal in 100 yrs". EconomicTimes. 7 August 2021. 8 August 2021.
2. "India beat Germany 5-4 in mens hockey win historic bronze medal". 9 August 2021.
3. "India vs Germany Bronze medal match;Olympics.com". 9 August 2021.
4. "Ravi Kumar Dahiya takes silver;Olympics.com". 10 August 2021.
5. "Bajrang Punia wins bronze in 65 kg ;Olympics.com". 10 August 2021.
6. "Ilovlina borgohain puts boromukhia on olympic map". 10 August 2021.
7. "India at the 2020 Summer Olympics;Olympics.com". 10 August 2021.
8. "Indian medal winners;indianexpress.com". 10 August 2021.
9. "India in tokyo olympics;Olympics.com". 10 August 2021.
10. "On this day Abhinav bindra became first Indian to win individual Olympic gold". 14 August 2021.
11. "Indian field hockey records". 14 August 2021.
12. "Olympic medallists to be considered for Khel Ratna: Sports Ministry". Scroll.in. 24 May 2016. 4 August 2021.
13. "Tokyo Olympics: Coaches of gold winners to get ₹12.5 lakh from IOA, Chanu coach to get ₹10 lakh". Hindustan Times. 24 July 2021. 4 August 2021.
14. Basu, Hindol (23 July 2021). "Tokyo Olympics: Indians to get highest cash award for winning medals". Times of India. 4 August 2021.
15. "Andhra Pradesh Government Announces Rs 30 Lakh Cash Reward for PV Sindhu". News18. 3 August 2021. 4 August 2021.
16. Pandey, Ashish (30 June 2021). "Andhra Pradesh Chief Minister YS Jagan Mohan Reddy gives Rs 5 lakh each to Olympic-bound athletes from state". India Today. 4 August 2021.



**ACADEMICIA**  
**An International  
 Multidisciplinary  
 Research Journal**  
 (Double Blind Refereed & Peer Reviewed Journal)

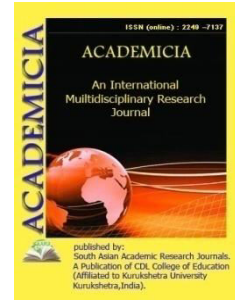

**DOI: 10.5958/2249-7137.2021.01971.6**

**PRODUCTIVITY AND MORPHOGENETIC DESCRIPTION OF  
 IRRIGATED SEMI-AUTOMORPH SOILS OF LIGHT SEROZEM SOIL  
 ZONE**

**Bobomurodov Sh.M\*; Bobonorov B.B\*\*; Ismonov A.J\*\*\*; Tursunov Sh.T\*\*\*\*;  
 Baxodirov Z.A\*\*\*\*\***

<sup>1,5</sup>Research Institute of Soil Science and Agrochemistry,  
 Ministry of Agriculture of Uzbekistan,  
 Tashkent, UZBEKISTAN

Email id: shuhrat\_bm@irbox. rubekzodbobonorov427@gmail.com, abduvahob60@mail.ru,  
 tursunov.sodmon.1976@gmail.com, zafarbahodirov@gmail.com

**ABSTRACT**

*The article provides information on non eroded and eroded irrigated serozem-meadow and meadow-serozem soils, which are illustrated by some examples of the Ak Altyn district, which is part of the flooded area of the Sardoba Reservoir in the Syrdarya region. Soil samples taken from these floodplains and floodplains were widely covered based on the results of analysis and field research, the amount of humus and nutrients, mechanical composition, carbonate and gypsum are analyzed, which determine soil fertility. It should also be noted that a detailed description of the morphological structure of genetic horizons is given. Irrigated serozem-meadow soils are moderately eroded by flooding and have a medium, light, heavy loamy and sandy mechanical composition, with physical clay particles of 31.8-42.1% and fine sand (7.9-51%), coarse dust (18.3-51.7%), il particles occur in the amount of 10.3 to 15.1%, of which fine sand and coarse dust particles predominate. In irrigated meadow-serozem soils, humus decreases along the cross-sectional profile, ie towards the parent rock, according to a certain pattern (0.118-0.278%). The mobile phosphorus is 297 mg/kg in the arable layer and the exchangeable potassium is 7.4 mg/kg. It was noted that these soils are very poorly supplied with humus and nutrients and in some cases moderately. Irrigated serozem-meadow soils are moderately eroded, with humus content in the arable layer ranging from 0.246%, mobile phosphorus from 79 to 136 mg/kg, exchangeable potassium from 0.6 to 2.2 mg/kg. In the semi-automorphic soils studied, the dry residue content ranged from 0.132% to 0.655% in both soils,*

mainly belonging to the chloride-sulphate and sulphate salinity types, and they were dominated by sulfate ( $SO_4^-$ ) ions (0.063 to 0.402%).

**KEYWORDS:** *Irrigated Serozem-Meadow Soil, Non Eroded, Eroded, Mechanical Content, Humus, Mobile Phosphorus, Exchangeable Potassium, Salinity, Dry Residue, Gypsum, Carbonate*

## INTRODUCTION

Effective use of irrigated lands involved in agriculture in the country requires protection of irrigated lands by maintaining and restoring the current state of fertility and productivity. To this end, continuous monitoring of irrigated soils, including the development of proposals and recommendations based on a scientific study of the soils of the disaster area is relevant today. It has also been reported that degradation processes in soils are accelerating, salinization is occurring, and humus and nutrients are greatly depleted.

**The purpose of the study** - The purpose of our work is to characterize the data of field and laboratory studies on the condition of irrigated serozem-meadow and meadow-serozem soils of the Akaltin district of the Syrdarya region.

**Object of the research and methods of implementation.** As objects of the study irrigated serozem-meadow and meadow-serozem soils of the flooded area Sardoba Reservoir were selected. These soils are intermediate phase soils that move from serozem soil to meadow soil or from meadow soil to serozem soil according to movement of groundwater level in time.

The basis of the research methodology includes field soil, laboratory-analytical, camera-analytical work. It was carried out at the Research Institute of Soil Science and Agrochemistry and on the basis of generally accepted national guidelines [1; 2; 3].

**Research results and their discussion.** The mechanical composition of soils, the scope of its influence on properties of soils is important, water retention, water permeability is also directly related to the mechanical composition. In addition, it is important for vital moisture content for plants, in determining quantitative criteria and balances of heat regimes [4; 5; 6;].

According to the results of soil analysis of irrigated soils of the studied area, non eroded area with medium and light loamy mechanical composition includes irrigated serozem-meadow soils (sample 21) with 30.2-37.4% in medium loamy, 24.6% in light loamy, coarse and fine dust particles and coarse sand particles predominate, 6.4-18.3% of clay particles (respectively 4.8-38, 2%, 10.3-19.9%, 18.5-69.8%).

Irrigated serozem-meadow soils (sample 20) are moderately eroded by flooding, with medium, light, heavy loamy and sandy loam mechanical composition along the profile, with physical clay particles 31.8-42.1%, respectively, 22, 3-23.9%, 19.1%, fine sand (7.9-51%), coarse dust (18.3-51.7%), clay particles from 10.3 to 15.1%, fine sand and large dust particles predominate.

The selected irrigated meadow-serozem soil (sample 21) is provided with a moderate content of (1.081%) arable layer of soil with humus, and it decreases along the profile, ie towards the parent rock, according to a certain pattern (0.118-0.278%). The mobile phosphorus is 297 mg/kg in the arable layer, the exchangeable potassium is 7.4 mg/kg, and they decrease to the bottom of the soil profile (64-110 and 1.2-3.8 mg/kg respectively). It was noted that these soils are very poorly



supplied with humus and nutrients and in some cases moderately. Carbonates (CO<sub>2</sub>) occur in the form of 5.30-6.44%, gypsum crystals in the amount of 0.697-4.198%.

Irrigated serozem-meadow soils (sample 20) were moderately eroded, with humus content in the arable layer 0.246%, gradually decreasing towards the bottom of the profile (0.064-0.182%), mobile phosphorus occurs 79 to 136 mg/kg, exchangeable potassium ranging from 0.6 to 2.2 mg/kg, these soils very poor, sometimes poorly supplied with humus and nutrients. Carbonates (CO<sub>2</sub>) are 4.08-6.09%, in the form of gypsum crystals in the range of 0.401 to 1.567%, in some layers of the soil are washed (5.87-9.553%) and observed as non-gypsum soils.

Taking into account the susceptibility of irrigated serozem-meadow and meadow-serozem soils to salinity, the movement, redistribution and accumulation of water-soluble salts along the soil profile, as well as the analysis of salt accumulation and secondary salinization processes plays an important role [7; 8; 9; 10].

Irrigated meadow-serozem soils are low saline at the arable and subsoil layer, moderately saline towards the bottom of the section, the dry residue content of water-soluble salts is 0.132-0.655%, mainly belongs to the chloride-sulfate salinity type, chlorine (Cl<sup>-</sup>) ion 0.028-0.063%, sulfate (SO<sub>4</sub><sup>-</sup>) ion is 0.063-0.402%.

Irrigated serozem-meadow soils are low-saline, 140-171 cm layer is not saline, mainly belongs to the type of sulfate salinity. The dry matter content of water-soluble salts is 0.132% in the unsalted layer, 0.345 to 0.445% in the low-saline layer, chlorine (Cl<sup>-</sup>) ion 0.007-0.014%, sulfate (SO<sub>4</sub><sup>-</sup>) ion 0.063 to 0.200% (Figure 1).

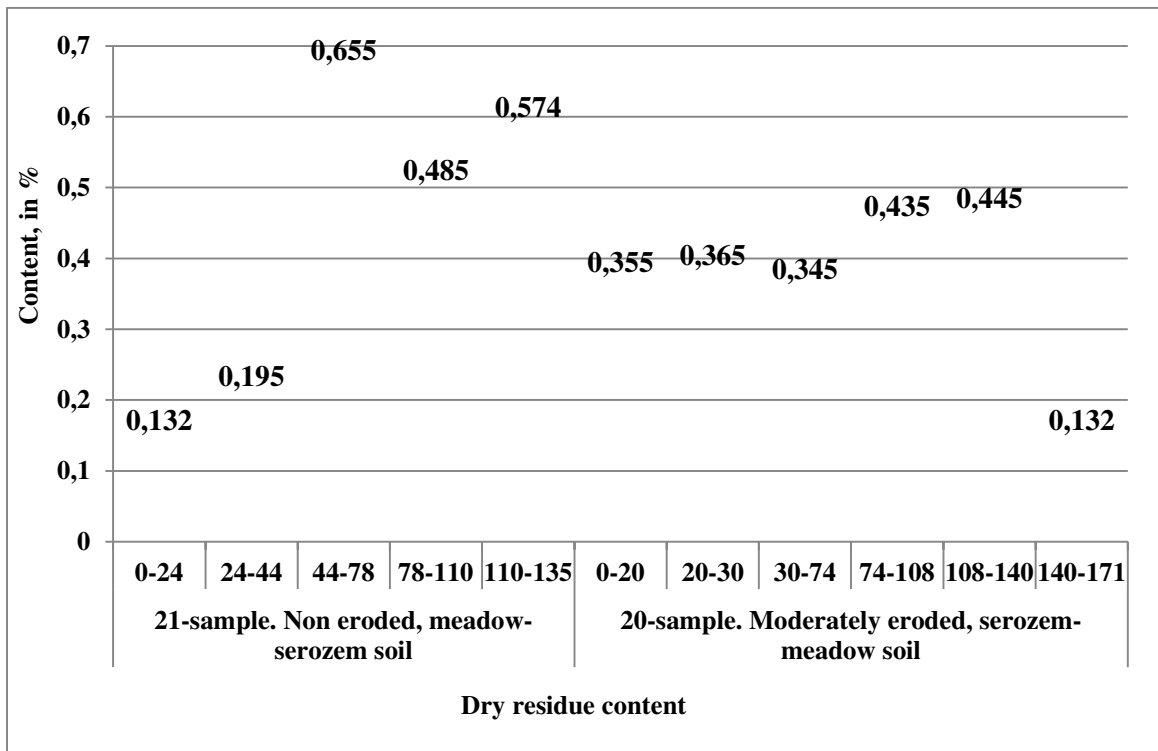

Figure 1. Content of dry residue in irrigated meadow-serozem and serozem-meadow soils



Field soil studies identified areas that were not flooded (sample 21) and moderately eroded (sample 20), from which separate soil samples were excavated and divided into genetic horizons. In the soils of this area, groundwater is located at a depth of 2.5 meters. The morphological structure of the studied sections is given.

21-sample. Bobonorov B.B. 09.04.2021. Sardoba massif of Akaltin district (non-flooded area), Central Mirzachul plain consisting of proluvial and lake deposits, irrigated meadow-serozem soils.

A<sub>a</sub> 0-24cm. Light gray, dry bottom moisture increases, medium loamy, large and fine-grained structure, soft, less dense, salts vascular, abundant insect traces and plant roots, semi-rotten plant remains are common, the transition to the next layer depends on the abundance of roots;

A<sub>sa</sub> 24-44cm. Light gray, moderately moist, moderately loamy, fine and in some cases large-celled structure, semi-rotten plant remains are abundant, plant roots are abundant, insect remains and traces are moderate, vascular salts are occasionally visible, the transition to the next layer is gradual depending on color;

B<sub>1</sub> 44-78cm. Compared to the top layer, light gray, moisture increases moderately downward, medium loamy, fine-grained structure, soft, salts occur in the form of fine crystals, gypsum crystals, decaying plant remains and roots are low, underground insect traces are low, the transition to the next layer is obvious according to mechanical composition and humidity;

B<sub>2</sub> 79-110cm. Light gray, very moist, slightly sandy, in a granular structure, soft, very few plant roots and insect traces, salts occur in the form of small crystals and gypsum crystalline state, according to the mechanical composition of the transition to the next layer;

C 110-135cm. Light gray, with a high moisture content, moderately sandy, fine-grained structure, soft, plant roots are sparse, insect traces are very rare, gypsum crystals are poorly expressed.

This soil sample is irrigated meadow-serozem soils with non eroded area, mainly due to the uniformity of mechanical composition, their exchange in some lower layers, moderate increase in humidity from the upper part to the dry lower part, the increase in humidity from 79-110 cm. The roots of the plant towards the bottom are sparse and the traces of insects are rare.

20-sample. Bobonorov B.B. 09.04.2021. Musamuhamedov massif, moderately eroded floodplain, Central Mirzachul plain consisting of lake-proluvial deposits, irrigated serozem-meadow soils.

A<sub>a</sub> 0-20cm. Light gray, the surface rises to the bottom of dry moisture, sandy, dusty structure, soft and less dense, salts in the form of small crystals, gypsum in small quantities, abundant semi-rotten plant remains, insect traces and remains moderate, according to the mechanical composition of the next layer ;

A<sub>s</sub> 20-30cm. Light gray, moderately moist, slightly sandy, with a fine-grained and dusty structure, less dense, occurs in the form of fine crystals of salts from new formations, plant roots are abundant, insect traces are moderate, according to the mechanical composition of the transition to the next layer;

B<sub>1</sub>30-74sm. Compared with the previous layer, it has a light gray color, less moist, medium sandy, fine-grained granular structure, low density, plant roots are sparse, insect traces are low, small crystals of salts and gypsum crystals are abundant, according to the mechanical composition of the transition to the next layer;

B<sub>2</sub>74-108sm. Very light gray, low moisture, heavy sandy, coarse structure, low density, very few insect traces, few fine crystals of salts and gypsum crystals, the transition to the next layer according to the mechanical composition;

C<sub>1</sub>-108-140cm. Very light gray, low moisture, medium sandy, granular structure, low density, gypsum crystals low, salts in the form of fine crystals, according to the mechanical composition of the transition to the next layer;

C<sub>2</sub>-140-171cm. Very light gray, low moisture, slightly sandy, dusty structure, low density, low gypsum crystals.

The erosion of the soil sections studied at the study site was relatively shortened, the mechanical composition varied, i.e., light - medium - heavy - light sand exchange, mainly low density, very light color from the subsoil (30-74 cm), salts occurring in the form of small crystals, its relative increase to the bottom of the section and a sharp decrease in plant roots and insect traces, the change of layers is sharply dependent on the mechanical composition.

In conclusion, it should be noted that both soils studied differ in mechanical composition (i.e., medium-heavy, light loamy), the intensity of exchange in some cases, irrigated meadow-serozem soils with humus and nutrients are very low (0-0.5%), (0-15, 0-100mg/kg) and low (0.5-1%), (100-200mg/kg) moderate in some cases (1.1-2%), (200-300 mg/kg), carbonates (CO<sub>2</sub>) 5.30-6.44%, gypsum content 0.697-4.198%, irrigated serozem-meadow soils are very poor in humus and nutrients, sometimes poorly supplied, carbonates (CO<sub>2</sub>) 4.08-6, 09% [11], in the form of gypsum crystals in some layers of soil washed (5.87-9.553%) and observed non-gypsum soils.

The amount of dry residue in both soils ranges from 0.132% to 0.655%, mainly belonging to the type of chloride-sulphate and sulphate salinity, the wide range of anions, ie chlorine (Cl<sup>-</sup>) ion from 0.007% to 0.063%, sulfate (SO<sub>4</sub><sup>-</sup>) ion from 0.063 up to 0.402% were recorded.

## REFERENCES

1. Arinushkina E. V. Manual for chemical analysis of soil. Moscow, 1975. - 491 p.
2. Kuziev R., Abdurakhmanov N., Ismonov A. Omonov A. // Instructions for maintaining a land cadastre, conducting soil prospecting works and drawing up soil maps. Tashkent, 2013. - 52 p.
3. Methods of studying the agrophysical, agrochemical and microbiological properties of soils in cotton fields. O'zPITI. 1963
4. Soils of Syrdarya and Djizak regions. Tashkent, 2005. –pp. 6-42
5. Kuziev R., Sektimenko V. E., Ismonov A. J. // Atlas of soil cover of the Republic of Uzbekistan. Tashkent, 2010. - 48 p.
6. Land fund of the Republic of Uzbekistan. Tashkent, 2019. 202 p.
7. Kachinskiy N.A. Soil physics. P. Vysshaya Shkola, Moscow. 1965. – pp. 20-300

8. Abdurahmonov N.Yu., Sobitov O'T, Kuziev J.M., Khalilova N.J., Mansurov Sh.S., Sanakulov S., Jumaev Sh.Kh. Current state and properties of newly irrigated soils of the Hungry Steppe. / Land administration and valuation: new approaches and innovative solutions. Materials of the Russian-Uzbek scientific-practical conference dedicated to the 100th anniversary of the National University of Uzbekistan named after Mirzo Ulugbek, Moscow-Tashkent 2019. pp. 317-320.
9. Kuziev R.K., Sektimenko V.E. Soils of Uzbekistan. Tashkent: p. Extremum Press, 2009. 351 p.
10. Urazbaev I.U. Salt tolerance of vegetables and melons and bonitet coefficients. Uzbek biological journal № 4, 2016. - pp.63-67.
11. Toshko'ziev M.M. Guidelines for the use of total humus and mobile humus in the soil as an indicator of its fertility. Tashkent, 2006



# ACADEMICIA

## An International Multidisciplinary Research Journal

(Double Blind Refereed & Peer Reviewed Journal)

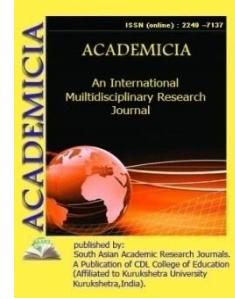

DOI: **10.5958/2249-7137.2021.01972.8**

## COMPARISON OF THE TURBULENCE MODEL FOR SWIRLED FLOWS

**Dilshod Qaxramonugli Khushvaktov\***

\*Tashkent State Transport University,  
Tashkent, UZBEKISTAN  
Email id: [sharingam@mail.ru](mailto:sharingam@mail.ru).

### ABSTRACT

*The article examines the turbulent flow of a fluid flow in a rotating pipe, which is called the Poiseuille-Couette-Taylor flow. The main approaches to the numerical simulation of turbulent flows in the annular region between rotating cylinders are considered. The calculated results are obtained, which correlate with the known experimental results. On the basis of a comparative analysis, the most suitable differential turbulence model is proposed for calculating the conjugate problems of hydrodynamics and heat transfer in a Poiseuille-Couette-Taylor flow.*

**KEYWORDS:** *Mathematical Model Of Turbulence Based On The Dynamics Of Two Fluids, SSG / LRR-RSM-W2012 Model, Swirling Flow.*

### INTRODUCTION

At present, the most effective approach to the study of turbulence is an analytical one, based on the initial premise that the Navier - Stokes system of equations describing the characteristics of an instantaneous fluid flow is acceptable for the mathematical description of turbulent flows. The main tools for calculating turbulent flows are numerical methods, the widespread use of which has become possible due to the rapid improvement of computer technology. However, despite the keen interest, until now there is no universal approach to the calculation of turbulent flows that would adequately reflect some aspects of these flows, which are manifested in various special cases.

The most accessible is the use of various turbulence models in combination with the Reynolds Averaged Navier-Stokes Equations (RANS). This approach to numerical modeling is less demanding on computational resources and therefore more accessible, and also does not have a pronounced limitation on the degree of turbulence of the flows under consideration. However, its application requires special attention to the verification of the obtained solution. All turbulence models used in the framework of the use of RANS equations contain empirical dependences and

coefficients calibrated for a certain kind of flows. Therefore, none of these models provides the most adequate results in all cases. Moreover, it is known [1,2] that simple algebraic models, within the framework of their applicability, can provide results no worse than more complex differential models. In addition, it should be borne in mind that this or that turbulence model can adequately reflect some features or patterns of the considered turbulent flow, and not reflect or distort others. In this case, the success of the calculation depends on which physical features are predominant in this particular case and to what extent.

Turbulence modeling currently used in aerodynamics is usually based on two-equation models using a linear relationship between Reynolds stress and mean strain rate tensors. This relationship is known as the generalized Boussinesq model. This can be overly restrictive in complex tasks typical of high lift aerodynamics, because many different flow phenomena can be present in one task. Therefore, it is necessary to look for turbulence modeling with a wider range of applicability than the Boussinesq model. Reynolds Differential Voltage Modeling (RSM), in which the simulated transfer equation is solved for each stress component, is in principle a more general class of models with a wider range of applicability. However, RSM is considered an overly complex approach to industrial design of high lift aerodynamics. On the other hand, two-equation models can be extended to a wider range of applicability by developing more complex nonlinear relationships between stress tensor and mean velocity gradient and turbulent scales. These relationships are commonly referred to as constitutive models. One might think that two-equation turbulence models consist of two more or less separate parts: a scale-determining model, which provides scalar information about turbulence, and a constitutive model, which defines the Reynolds stress tensor. Explicit Algebraic Reynolds Stress Models (EARSMS) represent an interesting and promising subset of nonlinear constitutive models. In this approach, part of the description of higher-order physical processes at the RSM level is transferred to the modeling level with two equations. The EARSMS approach is considered a suitable type of constitutive modeling for the present purposes.

### Statement of the problem

The physical formulation of the problem is shown in Figure 1. As can be seen from the figure, a laminar non-swirling flow enters the rotating pipe, and the flow at the outlet is completely turbulent and swirling. Therefore, a sufficiently long pipe is considered for, i.e. the length is substantially greater than its diameter. The considered flow is characterized by the Reynolds number, which is determined by the average flow rate and the radius of the pipe.

In the case of rotation, the rotation parameter  $N = \frac{\pi D^2 \Omega R}{4Q}$  is also entered, where where  $\rho$  is the density of the liquid,  $Q$  is the volumetric flow rate,  $\mu$  is the dynamic viscosity, and  $R$  is the radius of the pipe.

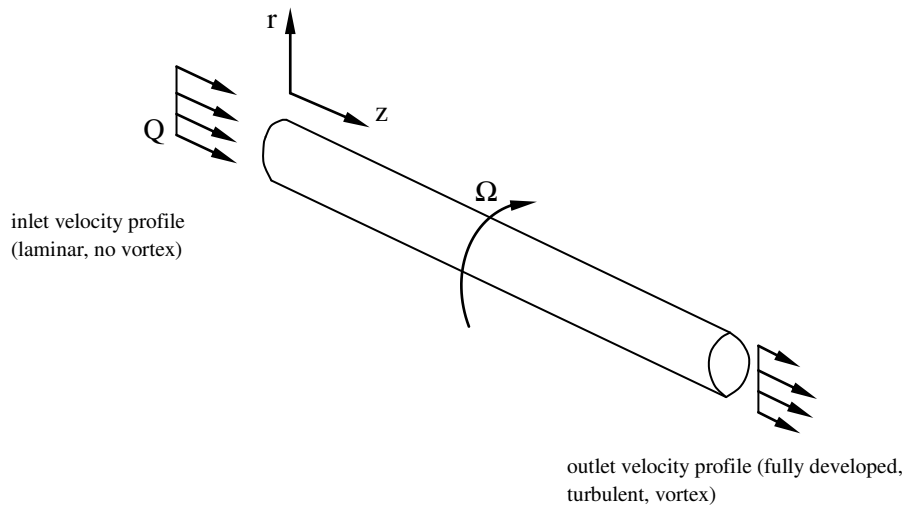

Fig. 1: Swirling flow through a rotating pipe.

### Mathematical modeling of the problem

For the numerical simulation of the turbulent flow of an incompressible fluid, the Reynolds equations were used [3]:

$$\begin{cases} \frac{\partial \bar{U}_i}{\partial x_i} = 0, \\ \frac{\partial \bar{U}_i}{\partial t} + \bar{U}_j \frac{\partial \bar{U}_i}{\partial x_j} + \frac{1}{\rho} \frac{\partial \bar{p}}{\partial x_i} = \frac{\partial}{\partial x_i} \left[ \nu \left( \frac{\partial \bar{U}_i}{\partial x_j} + \frac{\partial \bar{U}_j}{\partial x_i} \right) \right] + \frac{\partial (-\overline{u'_j u'_i})}{\partial x_i}. \end{cases} \quad (1)$$

The system of Navier-Stokes equations averaged over Reynolds (1) is not closed. For closure in methods, nonlinear turbulence approaches are used.

The mixed SSG/LRR second moment Reynolds stress model is a nonlinear RANS turbulence model that uses the omega equation for the length scale equation. Reynolds stress models with full second moment are very different from simpler linear or nonlinear single equation models, as the latter use a constitutive relation giving the Reynolds stresses  $\tau_{ij}$  in terms of other tensors through some assumed relation (such as Boussinesq's hypothesis). On the other hand, full second moment Reynolds stress models calculate each of the 6 Reynolds stresses directly (the Reynolds stress tensor is symmetric, so there are 6 independent terms). Each Reynolds stress has its own transfer equation. There is also a seventh transport equation for the scale variable. The complete Reynolds stress model SSG / LRR-omega (SSG / LRR-RSM-w2012) and one length scale equation are:



$$\begin{cases} \frac{\partial R_{ij}}{\partial t} + \frac{\partial \bar{U}_k R_{ij}}{\partial x_k} = P_{ij} + \Pi_{ij} - \varepsilon_{ij} + D_{ij}, \\ \frac{\partial \omega}{\partial t} + \frac{\partial \bar{U}_k \omega}{\partial x_k} = \frac{a_\omega \omega}{k} \frac{P_{kk}}{2} - B_\omega \omega^2 + \frac{\partial}{\partial x_k} \left( \left( \mu + \sigma_\omega \frac{k}{\omega} \right) \frac{\partial \omega}{\partial x_k} \right) + \sigma_d \frac{1}{\omega} \frac{\partial k}{\partial x_j} \frac{\partial \omega}{\partial x_j}. \end{cases} \quad (4)$$

Here,  $\rho R_{ij} = -\tau_{ij} = \rho \overline{u_i' u_j'}$ ,  $P_{ij}$  - generation of Reynolds stresses,  $D_{ij}$  - diffusion,  $\varepsilon_{ij}$  - dissipation,  $\Pi_{ij}$  - term of pressure redistribution. The remaining values of the initial and boundary conditions are presented in [1,2].

Malikov's new two-fluid turbulence model is presented in [4], which has the form

$$\begin{cases} \frac{\partial \bar{U}_i}{\partial t} + \bar{U}_j \frac{\partial \bar{U}_i}{\partial x_j} = -\frac{1}{\rho} \frac{\partial \bar{p}_i}{\partial x_i} + \frac{\partial}{\partial x_j} \left[ \nu \left( \frac{\partial \bar{U}_i}{\partial x_j} + \frac{\partial \bar{U}_j}{\partial x_i} \right) - u_j u_i \right], \\ \frac{\partial u_i}{\partial t} + \bar{U}_j \frac{\partial u_i}{\partial x_j} = -u_j \frac{\partial \bar{U}_i}{\partial x_j} + \frac{\partial}{\partial x_j} \left[ \nu_{ij} \left( \frac{\partial u_i}{\partial x_j} + \frac{\partial u_j}{\partial x_i} \right) \right] + \frac{F_{fi}}{\rho} + \frac{F_{li}}{\rho}, \\ \nu_{ij} = 3\nu + 2 \left| \frac{u_i u_j}{\text{def}(\bar{U})} \right|, \quad i \neq j, \quad \nu_{ii} = 3\nu + \frac{2}{\text{div}(\nu \mathbf{v})} \left| \frac{u_k u_k}{\text{def}(\bar{U})} \right| \frac{\partial \rho u_k}{\partial x_k}, \quad F_f = -\rho K_f u, \\ \frac{\partial \bar{U}_p i}{\partial t} + \bar{U}_j \frac{\partial \bar{U}_p i}{\partial x_j} = k_m (\bar{U}_i - \bar{U}_p i), \quad F_\perp = \rho C_s \text{rot} \bar{U} \times u, \quad \frac{\partial \bar{U}_j}{\partial x_j} = 0. \end{cases} \quad (5)$$

Here,  $u_i$  - respectively axial, radial and tangential relative velocities,  $C_s = 1$  Seffman's power factor,  $\nu_{ij}$  - kinematic molar viscosity,  $\text{def} \bar{U}$  - deformation of the average flow rate. The last equation is the kinematic equations for the solid phase.

### Results

In fig. 2. Numerical results of the nonlinear SSG / LRR-RSM model and two fluid models for longitudinal velocity are presented. The results of nonlinear turbulence approaches can be said to qualitatively describe the longitudinal velocity, while the two-fluid model describes quantitatively.

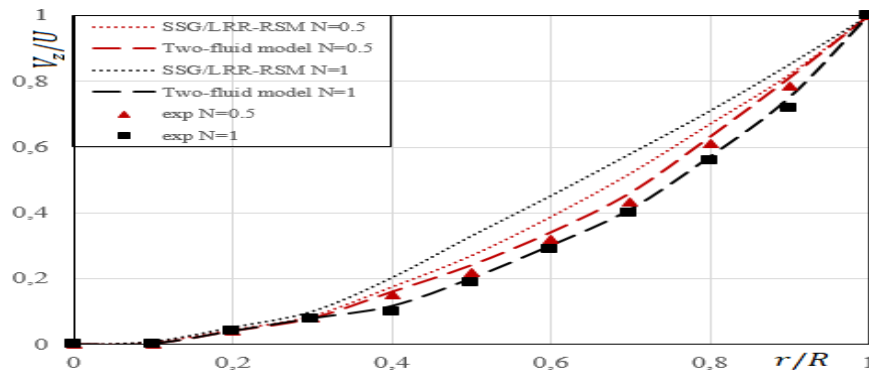

Fig. 2. Axial velocity profile in a rotating tube

In fig. 3. numerical results of both models for the tangential flow velocity are presented.

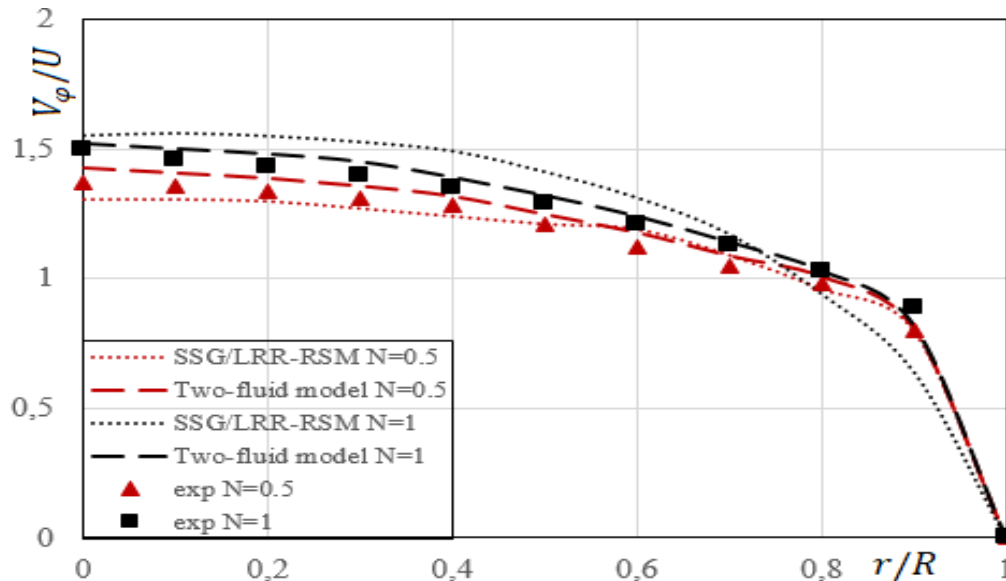

Fig.3. Tangential Velocity Profile in a Rotating Tube

It can be seen from this figure that the nonlinear model SSG / LRR-RSM is not even qualitatively able to describe the tangential velocity, which confirms the above statements. As for the new model, we can observe good agreement with experimental data..

## CONCLUSION

The model demonstrated simplicity for numerical implementation and good robustness. The new model is economical in terms of counting time. For example, in comparison with the SSG / LRR-RSM-w2012 model, the model allows integration with a time step of 20 times more.

## REFERENCES

- [1] Garbaruk A.V., Streles M.X., Shur M.L. «Modelirovaniye turbulentnostiv raschetax slojnyx techeniy [Modeling turbulence in complex flow calculations]» // SPb, Izd-vo Politexnika. un-ta, 2012. S.88.
- [2] Shur, M., Strelets, M., Zaikov, L., Gulyaev, A., Kozlov, V., Secundov, A., "Comparative Numerical Testing of One- and Two-Equation Turbulence Models for Flows with Separation and
- [3] Loysyanskiy L.G. Mexanika jidkosti i gaza [Mechanics of liquid and gas] // Mackva. Nauka, 1987.-678 s.
- [4] Malikov Z. Mathematical model of turbulence based on the dynamics of two fluids // Applied Mathematical Modelling: <https://doi.org/10.1016/j.apm.2020.01.047>

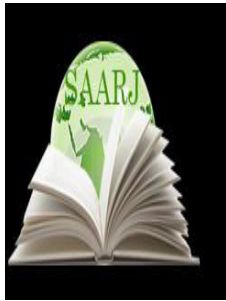

**ACADEMICIA**  
**An International  
 Multidisciplinary  
 Research Journal**  
 (Double Blind Refereed & Peer Reviewed Journal)

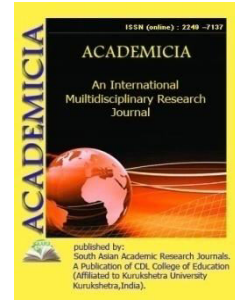

**DOI: 10.5958/2249-7137.2021.01973.X**

## PEDAGOGICAL ENVIRONMENT FACTOR IN THE DEVELOPMENT OF THE EDUCATION SYSTEM: PROBLEMS AND APPROACHES

**Ravshan Yarashevich Ergashov\***

\*Deputy Chief of Educational Staff,  
 Higher Military Aviation School of the Republic of UZBEKISTAN

### ABSTRACT

*During the years of independence, the development of the education system, which is an important sector of socio-economic, political, ideological and cultural life of the country, is one of the vital factors that directly affect the formation of spirituality. The radical reforms being carried out today, their content and essence are steadily developing in line with the requirements of world standards, are intertwined with the traditions of our people, our rich history and spirituality. First of all, the legal framework for these radical reforms has been created, which in turn has laid the foundation for the creation in our country of competent personnel with modern knowledge and thinking, well-rounded, able to meet the requirements of advanced world standards. The education system has been one of the most pressing issues in the history of our country.*

**KEYWORDS:** *Education System, Spiritual Values, Development, Innovative Ideas, Informational Technologies, Professional Skills, The Law "On Education", "National Training Program", Development Concept, Innovative Cluster System, Continuing Education, Intellectual Resource, Scientific And Methodological Structures, Pedagogical Education Cluster*

### INTRODUCTION

#### The main part

If the root of a tree is the deeper and more branched, the stronger it is, the longer its life, and the more abundant its fruit. For thousands of years of human development, mankind has not been able to discover a more effective means of developing society than education, science, and the profession. That's why education, science is an important factor that determines the future of any society, nation and state, and serves its development.

Education can achieve its results only if it has its roots in science and industry, social life, in a word, connection with life, and is fully integrated with internal and related networks. and a state that is able to provide a deep, all-round continuing connection between science, education and the economy, and which can be applied to all spheres of public life, will prosper. It is no secret that our country is doing a lot in the field of education.

From the first days of the independence of Uzbekistan, our state has paid special attention to this area, and the implementation of radical reforms has become one of the main tasks. The further development of the nation with the youth can be seen in the meaning of spirituality, which has become the greatest wealth, its place and importance in the life of man and society. One of the bases of spirituality is history. Indeed, in the XXI century of information technology, the people's memory, the need to understand the reality of the past, which can resist foreign ideas, is growing from year to year, innovative ideas and approaches raise the attitude to history to a higher level. However, the efforts to ensure that our spiritual values are enriched with the achievements of science and development have paved the way for the development of our country in accordance with world experience.

Drastic improvement of the education system, identification of target areas for the training of highly educated specialists, in particular, continuous improvement of professional skills and knowledge of teachers are among the most pressing issues. It is no coincidence that the Address of the President of the Republic of Uzbekistan to the Oliy Majlis on the most important priorities for 2019 emphasizes the relationship between science and education, education and socio-economic life. Because human capital is in the center of the education system, its proper distribution, its effective use and targeted orientation, including the organization of the system of pre-school, general secondary and higher education in accordance with the requirements of today in a holistic way with all stakeholders of society, all subjects of the educational process, achieving complete continuity is one of the important tasks before us.

### **Review of literature on the subject**

The problem of forming preparation of future professionals for innovative activities is multifaceted, but its solution is mainly related to the solution of the contradiction between the social order for the training of competitive professionals and the possibility of its implementation. Many educators and scientists have conducted research on the specific and general aspects of innovation.<sup>35</sup> For example: N.N.Azizkhodjaeva, B.L.Farberman, N.Saidakhmedov, M.Ochilov, B.R.Adizov, M.H.Makhmudov, S.Ziyamuhamedova, B.Ziyamuhamedov, U.Nishonaliev, R.Juraev, U.Tolipov, Russian scientists V.P.Bespalko, M.T.Gromkova, V.A.Slastenin, L.S.Podymova, M.V.Klarin, Y.P.Morozov, P.I.Pidkasisty, N.V.Konoplina, A.Y.Nayn, M.M.Potashnik, Khutorskiy A.V., N.R.Yusufbekova, V.I.Andreev, P.G.Shedrovskiy and others. The concept of innovation is interpreted differently in the scientific and pedagogical literature. Under the word innovation, V.I.Andreev understands the novelty, originality, which is introduced into the educational process at school.<sup>36</sup> A.Y. Nainsays: "Innovation means a completely new education (a special approach), a new idea that changes the essence of existing educational technology, a new type of educational institution or education

<sup>35</sup> K. Olimov and others. Methods of professional education. Textbook.2015y.

<sup>36</sup> Ishmuhamedov R., Abduqodirov A., Pardaev A. Innovative technologies in education (practical recommendations for teachers of educational institutions). -T.: Talent Fund, 2008 -180 p.

management,". M.M. Potashnik understands innovation as the process of acquiring innovation. P.G. Shedrovsky says that this is an attempt to transfer an organized activity from one field to another. A.F. Balakirev in his work, based on the fact that this concept is derived from Latin (in-, nova-new), argues that the term innovation should be interpreted as innovation, the introduction of innovation.

We believe that innovation is a subjective innovation that is new to a particular person or institution, while others are already sufficiently aware of it.

N.I. Lapin interprets the word "innovation" in terms of etymology and believes that its implementation means the creation and use of something new.<sup>37</sup> It is a novelty that has emerged in response to a particular social need and represents a practical means of satisfying that need. The process of creating, acquiring, using and disseminating innovation in pedagogical practice in education is also called an innovative process. Innovations in education do not always have a theoretical basis, because innovative teachers usually develop their own authorized works, concepts, new programs, methods in practice.

## **MATERIALS AND METHODS**

The fundamental changes that have taken place in recent years have necessitated a rethinking of new innovative approaches, existing views, concepts and attitudes to all spheres of public life with a mirror of development and efficient criteria. Noting that a lot of positive work has been done in the field of education and training during the years of independence, it should be noted that the inability to clearly define the goals and methods and means to achieve them, in-depth study of labor market requirements, inconsistencies in supply and demand serious mistakes and shortcomings were also observed as a result of disregard for social status and aspirations. As a result, the requirements of the Law on Education and the National Training Program have not been fully implemented. Over the years, we have focused more on finding our own unique and appropriate path in education and training, as in all areas.

Indeed, in recent years, President Shavkat Mirziyoyev has drastically reformed the education system and radically improved the quality of training and began to pay seriously attention to improving, in particular, the application of the experience of developed foreign countries in the system. Reforms in this area were introduced on March 14, 2017 "On measures to further improve the activities of secondary special, vocational education institutions", on April 20, 2017 "On measures to further develop the higher education system" On measures to further improve the system of postgraduate education, dated May 22, 2017, on August 8, 2017, on the activities of the Ministry of Public Education of the Republic of Uzbekistan. This is reflected in the Presidential Decrees of September 30, 2017 "On the establishment of the Ministry of Preschool Education of the Republic of Uzbekistan." If we pay attention, we can see that these decisions cover almost all types of continuing education. In addition, the "Strategy for further development of the Republic of Uzbekistan in 2017-2021" focuses on basically improvement of education. All of these documents, aimed at developing and improving the education system, have common aspects related to the introduction of innovations in the field, the adoption of foreign experience,

---

<sup>37</sup> Zeer EF, Shakhmatova N. Personality-oriented technologies of professional development of a specialist. - Yekaterinburg, 1999.-244 p.

support for creative approaches, strengthening the integration process between types of education.

The study of existing omissions in the education system of Uzbekistan and their analysis showed that the coordination of pedagogical education, future planning, the lack of communication and integration between the stages of education, the subjects of education. The fragmentation of their activities has led to the necessity for pedagogical staff in the region and a decline in the quality of education. As a result, the new system of creating an innovative cluster of pedagogical education in some higher education institutions has been identified as a strategic priority, and certain work has been done on the basis of this system. The system envisages the introduction of a cluster approach to education, which is considered effective in light industry, a number of sectors of agriculture and manufacturing sectors of the economy.

Indeed, there is a chain of production, processing and conversion of raw materials into finished products and their sale in the manufacturing sector, and this sequence is also present in the form of human capital in the pedagogical education system. This shows that it is theoretically possible to introduce an effective cluster model into the education system.<sup>38</sup>

Given the high social significance of pedagogical education in the sustainable development of society, modern requirements, problems in the system and ensuring the connection between science and education in solving them Transfer of continuous pedagogical education to the cluster development system requires.<sup>39</sup>

The innovative cluster of pedagogical education is a whole of all types of education in the system of continuing education, research institutes and centers, bases of practice, scientific and scientific-methodical structures, and their shared functions contribute to the quality of the pedagogical education system. allows you to take it to a new level.<sup>40</sup> Therefore, the main goal of the cluster is to increase the educational-scientific-innovative potential of the cluster, not only with a high level of civic and professional competence, but also competitiveness, ability to accept innovations, design and implementation of new educational programs and technologies is to unite to train modern education professionals.

Before we begin to explore the content and direction of the introduction of innovative methods in the education system, let's define the concept of "Pedagogical system" and "Innovation in the pedagogical system." We know that the pedagogical process is based on the pedagogical system. The pedagogical system is a cohesive set of founders who remain resilient to change.

What if there is a change?

if it exceeds the possible limit, the system breaks down and is replaced by a new system with other features. The pedagogical system is a very strong combination of elements. The structure of any pedagogical system today consists of a set of the following elements, which are interrelated: student; the purpose of education; educational content; educational process; teachers

---

<sup>38</sup> Yunusova S.F. The problem of training highly qualified personnel in Indian universities (1960-1970): Dis. ... Cand. ist. Sci., T., 1981, 168 p.

<sup>39</sup> Kuvvatov N.B. Training and education of teaching staff in Uzbekistan: experience and problems (1980-1990) Author's abstract. dis. ... Cand. Historical Sciences - T., 1994 .-- 21 p.

<sup>40</sup> R.E. Kholikova Development of higher history education and science in Uzbekistan: Author's abstract. dis. ... Cand. ist. nauk.- T., 1995.-26 p.



(or TTV - technical means of education); organizational forms of educational work. Each of the components of this system can be broken down into elements of any size. The pedagogical system is a relatively independent part of management, uniting all its components, because they have their own goals and structures. Emphasizing the unity of individual factors as an integral part of the pedagogical system, they are often referred to as the technology of the educational process.

## **RESULTS AND DISCUSSIONS**

The cluster system of pedagogical education development works in general areas related to teaching, creation of textbooks, increasing the scientific potential of teachers, integration of education and upbringing. At the same time, these general areas are being privatized in the areas of education management and organization, ensuring continuity and integration between types and areas of education, and the use of teaching methods and tools. The following are the subjects of the cluster system:

- pre-school, general secondary, secondary special, higher and post-secondary education, where students, masters and doctoral students undergo pedagogical practice, educational and research activities, innovative and design activities and serve as an experimental base. additional educational institutions;
- Institutions of additional education for adults in accordance with the updates at different levels of education, institutions for retraining and advanced training of teachers of preschool, general secondary, secondary special vocational education of children and adolescents;
- Scientific and methodological structures, centers, research institutes engaged in and defining joint research activities;
- pedagogical communities, initiative groups, public associations, governmental and non-governmental organizations;
- Foreign higher education institutions and research centers.

The cluster system unites the entities, each of which operates separately, around a common goal, and at the same time, each entity operates on the basis of a common interest based on a common goal. The subjects of the cluster system support and control each other, each of which creates a spiritual and intellectual space of a separate cluster, expanding its social influence and importance. The innovative cluster of pedagogical education is based on the principles of relevance, membership, consistency, succession, modernity, focus, interest.

The main objectives of the pedagogical education cluster are:

- Ensuring effective succession in the field of pedagogy and promoting the best students in the teaching profession;
- Carrying out professional training of teachers based on practice and intensively ensuring effective communication with stakeholders;
- creating an environment for training future education professionals on the basis of internships with innovative experience;
- shortening the period of professional development of young professionals;

- Ensuring the direct participation of students in today's rapid development;
- Creation of a new generation of pedagogical, educational-methodical, scientific literature, tools and didactic materials in pedagogical education;
- increase the scientific, scientific and pedagogical potential of pedagogical education;
- Integration of intellectual resources around topical issues of pedagogical education development;
- search for and apply to education various forms and types of education, science and pedagogical practice;
- Improving the mechanisms of integration of education and upbringing;
- creation of opportunities for rapid interaction with preschool, secondary and higher education institutions and other applicants in the training of teachers;
- Scientific substantiation of the need for connection, interdependence and cooperation between the links of pedagogical education.

Based on these goals, the innovative cluster of pedagogical education performs the following functions:

- Training of teachers with modern knowledge and skills for educational institutions in the region;
- effective use of innovative pedagogical technologies to improve the quality of education;
- Consistent scientific activity in the field of pedagogy;
- Ensuring the continuity and continuity of the content of the main (textbook) and auxiliary means of education (dictionaries, encyclopedias, electronic sources, etc.) in the stages of education;
- organization of periodic training courses in cooperation with the regional Department of Public Education in order to fill the gaps in the level of knowledge of teachers of educational institutions in the regions;
- Organization of scientific-practical seminars in cooperation with the regional Department of Public Education in order to address the problems associated with the teaching of science in secondary schools;
- strengthening scientific cooperation with research institutes, research centers and basic higher education institutions in order to increase the scientific potential of professors and teachers in the institutes;
- Involvement of teachers with the ability to conduct research in secondary schools in research work;
- Internships at leading foreign universities in order to learn best international practices in the field of pedagogy.

Currently, the innovative cluster of pedagogical education has been identified as the main research area of the institute, and now more than thirty professors and teachers are conducting

research in this area of research. All our efforts are aimed at ensuring the full implementation of the tasks set by the decree of the President, meeting the needs of the region in teaching, training of modern competitive teaching staff with the involvement of advanced foreign experience in the field. In this way, the team of the institute will make a modest contribution to the implementation and implementation of the priorities and tasks set out in the "Strategy of Action".

## CONCLUSION

In conclusion, it should be noted that the education system will have a strong organizational and technological complex that will ensure the achievement of the goals set by the development of innovative methods. It should be noted that the pedagogical system is always a technology. It is on this basis that it is easy to distinguish from the arbitrary "set" of components of the pedagogical system. Technology is the intrinsic quality of a system that determines its capabilities, subject to strict organizational logic. However, even at the level of task evaluation, the technologist relies on certain processes and events. Certain processes are used as evidence of success, and the results of remarkable events are realized as sources of new causes and formulas.

Indeed, at the current stage of development of our society, the innovative cluster of pedagogical education provides internal and intersectoral linkages in education, the experience gained in scientific research, scientific and methodological institutions and the achievement of scientific achievements in all spheres of education and socio-economic life, is presented as the most important system in the near future that will perform effectively. At the same time, it is necessary to ensure the interconnected and uninterrupted interaction of educational institutions and other stakeholders of society, the end product of the educational process - the training of highly qualified teachers and it is desirable to create scientific, creative, spiritual, economic opportunities for the benefit of society. Because the level of knowledge and competitiveness of the staff is the basis for the development and competitiveness of economic production, industry, agriculture and other sectors of society. The experience of developed countries, as well as life itself, clearly shows that the quality and effectiveness of everything we do is closely linked to this issue.

## REFERENCES:

1. Ishmuhamedov R., Abdukodirov A., Pardaev A. Innovative technologies in education (practical recommendations for teachers of educational institutions). -T.: Talent Fund, 2008 -180 p.
2. K. Olimov and others. Methods of vocational education. Textbook.2015y.
3. Zeer E.F., Shaxmatova N. Personally-oriented technologies of professional development specialist. -Yekaterinburg, 1999. -244 s.
4. G.O.Ernazarova. Formation of professional creativity of future specialists / International scientific journal "Education and upbringing" (ISSN 2410-4515), 2020, №5.74-77 p.
5. Xalbaev S. Stanovlenie i razvitie universitetskogo obrazovaniya v Uzbekistane (1918-1928 gg.): Avtoref.dis ... kand.ist.nauk.- T., 1974. -26 s.
6. Yunusova S.F. Problem podgotovki vysokokvalifitsirovannyx kadrov v Universitetax Indii (1960-1970 gg): Dis. ... Kand. ist. nauk.- T., 1981. - 168 p.

7. Sharipova R.M. The role of the university "al-Azhar" in the socio-political and ideological life of the OAR (ARE) at the present stage: Avtoref.dis. ... Kand.ist.nauk.- M., 1972. Avtoref.dis. ... Kand.ist.nauk.- T., 1974. -26 p.
8. Quvvatov N.B. Preparation and upbringing of pedagogical staff in Uzbekistan: experience and problems (1980-1990) Author. dis. ... Kand. ist.nauk.- T., 1994. -21 p.
9. Kholikova R.E. Development of high historical education and science in Uzbekistan: Author. dis. ... Kand. ist. nauk.- T., 1995. -26 p.
10. Hamdamov Yu. The fruit of national university independence // People's speech. - 2000. - 3 fev.
11. Kasimov B. University and modern intellectuals // Ma'rifat. - 2003. - 28 May.
12. Valiev A.K. Problems of development of spiritual culture // General science in Uzbekistan. - 1992. - № 3. - S.17.



**ACADEMICIA**  
**An International  
 Multidisciplinary  
 Research Journal**  
 (Double Blind Refereed & Peer Reviewed Journal)

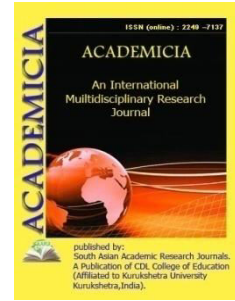

**DOI: 10.5958/2249-7137.2021.01974.1**

## THE STUDY OF KOMIL KHOREZMI'S LIFE AND LITERARY HERITAGE IN UZBEK LITERATURE

**Shahobiddin Babayarovich Nuriddinov\***

\*Doctoral student,  
 Karshi State University, UZBEKISTAN  
 Email id: shahnur.82@mail.ru

### ABSTRACT

*In this article, the study of the life and creative heritage of Kamil Khorezmi in Uzbek literature is examined. The works of historiography and literature, as well as information in scientific articles were analyzed in detail. It is clear from the sources that Kamil Khorezmi was a talented composer and musician. Tazkiranavis praised Laffasi Kamil's musical skills and recalled that he was unique in his time playing the tanbur [8:20]. The information in the "Musical History of Khorezm" that "he died in the morning on the 27th of Sha'ban 1317" is reliable. First, the date is clearly indicated in the next play. We think that it is worthwhile to dwell on various aspects of Kamil Khorezmi's activity. Scientific sources contain a number of information about Kamil Khorezmi's publishing and calligraphy activities.*

**KEYWORDS:** *Calligrapher, Musician, Translator, Devon, Press, Creative Activity, Scientific Research.*

### INTRODUCTION

Kamil Khorezmi is a mature poet, calligrapher, composer, musician, translator and statesman who has a special place in the cultural and social life of the Uzbek people. His exemplary work was in the spotlight of his contemporaries and later scholars. The study of the life and creative activity of Kamil Khorezmi, mentioned with great respect in the works of his contemporaries such as Ogahi, Tabibi, Bayani, has risen to a new level since the 40s of the last century.

Famous literary scholars provide valuable information in many articles covering various aspects of the life and creative activity of Kamil Khorezmi. The results of the research show that one of the urgent tasks of literary criticism is to create a monograph-based research with an in-depth analysis of Kamil's life and work on the basis of reliable sources.

The interest in Kamil's life and work, the encouragement to study it, began during the poet's lifetime. In particular, the poet's contemporary Ogahi in his work "Gulshani Davlat" wrote: "Navrasfirkvatozatab'shuarodin, fazlvahunarahliorasindamumtozPahlavonNiyozkim, fozillarguruhiichrataxallusiKomildir"[Pahlavon Niyaz is one of the most innovative and pure poets, the most famous among the masters of science and profession]. Clearly, the recognition of a classical word artist like Ogahi shows that Kamil has a high creative potential. Sheikh Suleiman Bukhari in his work "Lugatichigatoyivaturkiusmani" published in Istanbul in 1880, a brilliant scholar of Turkic languages, used the poems of Kamil Khorezmi, along with poets such as Navoi, Lutfi, Babur, Munis, Ogahi, Feruz. In the preface of the book, the author notes that he took examples from his own dictionary from the poetry of famous poets ("mashohirshuaro") [2: 2]. This single example proves that Kamil's work was recognized by his contemporaries during his lifetime. There are a number of manuscripts and lithographs composed by the poet in the late 19th and early 20th centuries. Some of his poems were published in the first sample of the Uzbek press, the Turkestan regional newspaper.

We think that it is worthwhile to dwell on various aspects of Kamil Khorezmi's activity. Scientific sources contain a number of information about Kamil Khorezmi's publishing and calligraphy activities. Mulla Bekjon Rahmon ogli and Muhammad Yusuf devonzoda wrote in his work "Musical history of Khorezm" that "Kamil Khorezmi ... was one of the first poets and editors of Khorezm" [17:62]. A. Murodov, a researcher of Central Asian calligraphy, wrote in his book "From the history of Central Asian calligraphy" that "Kamil Khorezmi ... was a talented composer, master calligrapher; famous painter ... Kamil was quickly recognized in calligraphy and music"[11: 113]. Kamil Khorezmi as a calligrapher in collaboration with Alisher Navoi's "Badoeul vasat", "Navodirush-shabab", as well as Agahi's "Tawiz ul-oshiqin", "DevoniRojiy", "DevoniFeruz", "Devonimajmuaighazaliyot" and collaboration with Mulla Qurbonniyaz, He copied the "DevoniKomyob" and the manuscript of "Latoyifut-tavoyif" (translation). As a publisher (he began his career in 1880) in the Khiva printing house, he prepared Alisher Navoi's works "Khamsa" (1881) and "Khazoin ul-maoniy" ("Chordevon" - 1882) for publication. In this work, he carefully studies the works of Kamil Navoi, draws on the publication the texts in the most perfect manuscripts, and takes great responsibility for the work of publishing. In the first edition of both works, great forewords are also written. Along with many figures of Uzbek literature, Kamil Khorezmi considers Navoi as his mentor in art. That is why, the great poet shows devotion as a promoter of his works. In calligraphy, he taught such master calligraphers of Khorezm as Master Muhammad Panoh, Khudoibergan Muhrkan Devon, Muhammad Sharif Devon, Matyokub Harrot Devon, Muhammad Rasul.

According to historical data, on the recommendation of Feruz, Kamil Khorezmi was responsible for the quality and perfection of all publications. This, in turn, testifies to the fact that Kamil Khorezmi was a mature enlightened person.

It clear from the sources that Kamil Khorezmi was a talented composer and musician. Tazkiranavis praised Laffasi Kamil's musical skills and recalled that he was unique in his time playing the tanbur [8:20]. This information is confirmed by the poet's ghazal "Tanbur". In the ghazal, the poet describes the tanbur with special affection. Literary critic R. Majidi writes about it: "Kamil used to practice tanbur, gijjak and santur very well". For this reason, he attended music nights in the presence of the khan; Kamil himself gives information about this in his somewhat humorous ghazal [9:23]. His compositions "Murabba'iKomil" and "PeshraviFeruz" are still



performed today. Kamil's greatest contribution to the field of music was the recording of Uzbek melodies. For this reason he attended music nights in the presence of the khan; Kamil himself gives information about this in his somewhat humorous ghazal [9:23]. His compositions "Murabba'i Komil" and "Peshravi Feruz" are still performed today. S.L. Ginzburg, a Russian composer and music theorist, writes about Kamil's work in the field of music: "Finally, it is interesting to note that under the influence of direct acquaintance with Russian culture in Khorezm in the 80s of the last century by Pahlavon Niyaz Mirzaboshi invented a special tabular note for tanbur" [3:22]. Indeed, Kamil Khorezmi's travels to St. Petersburg with Feruz had a great influence on the creation of the note line.

Another aspect of Kamil Khorezmi's activity is his translation. As a skilled translator, he translated a number of popular works in the East into Uzbek. In particular, by the decree of Feruz Barkhudor bin Mahmud Turkman Farahi (nickname is Mumtoz), he translated "Mahbub ul-qulub" (second name is "Mahfiloro") in 1864, Fakhriddin Ali Safi's "Latoyifut-tawayif" ("Anecdotes of various groups") and "Latayifut-zaroyif" ("Various clever and elegant (beautiful) anecdotes") in 1869. Among them are the translations entitled. In the Anthology of Uzbek Poetry, the writer Oybek writes that Kamil translated "Rano and Zebo" from Persian [16: 190]. However, it is clear from the sources that this work was not translated by Kamil, but by his son Muhammad Rasul Mirza. It is worth mentioning one controversial issue in Kamil's translation career. Said Muhammad Khan ordered Kamil to translate one of the books classified by Amir Temur. In the process of perfect translation, the poet consults with Roji on some issues. When the translation is ready and presented to the khan, Roji claims, "I translated the work, not Kamil". There is a fifty-byte masnavi in Kamil's devon, and the situation is described in detail by the poet. Suffering from injustice, Kamil addresses the khan:

Yomangayonabirkitobbering,  
*[Or give me a book]*  
 Turkqilgildebonjavobbering.  
*[And order me to translate it to turkish]*  
 Menibiruydaaylabonmahbus,  
*[Leave me as a prisoner in a house]*  
 Eshikindogiqildurungmadrus.  
*[Say them to lock the doorlock]*  
 Harnakimbulgusidururdarkor,  
*[Everyone is welcome]*  
 Istaganchoгдаqildurungtayyor.  
*[Ready to go whenever you want]*  
 Tunukunsay' birlaso'z bitoyin,  
*[I write a word day and night]*  
 Toulishintihosigaetoyin

*[And I complete the job]. [4:13-14]*

Apparently, Kamil believed in his creative potential. In general, this situation is a controversial issue, and we think that further research will clarify this.

Valuable information about the life and creative activity of Kamil Khorezmi can be found not only in literary works, but also in historical works. Muhammad Yusuf Bayani, a contemporary of the poet, writes: "Two years later, in the year one thousand three hundred and seventy-seven of the Hijrah, the year of the cow, Ibrahimkhoja passed away, and the palace of the world passed away forever. Then he had four sons. The first was Ismailhoja, the second was Islamkhoja, the third was Ishaqhoja, the fourth was Muhammad Yaqubkhoja, The history of Pahlavon Mirzoboshi was at least five to twenty bytes for the death of his mother. Byte:

KomilulSayyidyuzinkurmaydedi,

*[Kamil said that he doesn't want to see that Sayyid]*

XujaIbrohimijannatjoygoh.

*[Xuja Ibrahim is in a paradise]*

Let me not hide the fact that this history was more than sixty hundred. With practical taste, he said, "Sayyidyuzinkurmaydebsen [You say you don't want to see Sayyid's face]" referring to the isqat of the number. Chun said, "You" are sixty, and if you are sixty, history will be right". [1:79]. It is noteworthy that this history quoted by the historian and other poems created in this genre serve as an important source in the study of the creative biography of Kamil Khorezmi, his place in the literary environment of his time, his place in the social life of the khanate. This, in turn, highlights the need for more extensive research on the sources of the poet's literary heritage.

Kamil's younger contemporary Hasanmurad Laffasi's work "Tazkirai shuaro" provides valuable information about the life and work of the poet and examples of his poems [8: 19-24].

From the second quarter of the last century, special attention was paid to the study of the life and work of Kamil Khorezmi. Compiled by the literary critic Olim Sharafiddinov before the Second World War, "The Chrestomathy of the History of Uzbek Literature", published in 1945, gives a brief account of the poet's life and work and includes examples of his poems. In 1948, literary critic Mahmudali Yunusov defended his dissertation on the life and work of Kamil. The book "Komil Khorezmiy", which emerged as a result of the author's research, was one of the important achievements in the field. In the volume III of the "Uzbek literature" which had 4 volumes and about Kamil Khorezmi contains 15 ghazals of the poet, one muhammas, one masnavi, the continent. It was published in 1959. In 1961, Rahmat Majidi published the poet's "Tanlanganshe'rlar". The collection includes 28 ghazals, 4 muhammas, one masnavi (abbreviated), rubai and fardpoems [7].

It should be noted that in the monograph of Professor G. Karimov "History of Uzbek literature" (book 3) a fair attention is given to the study of Kamil's work. The play explores the period and literary environment in which the poet lived, his biography, the artistic features of his poetry, the scope of the subject and the characteristics of the genre, as well as his translation [5: 227-256]. In the press of the 70s, a number of articles were published devoted to the study of perfection. Such as, in M. Yunusov's "Komil" ("Sharqyulduzi", 1956, №11), G. Karimov's "Singer of noble

intentions” (“Sharqyulduzi”, 1976. №1), V.Zohidov's“Barkamoladib” (“Uzbekistonmadaniyati” newspaper, September 3, 1976), A. Hayitmetov's“Ilgorgoyalarkuychisi[Song of Advanced Ideas]” (Soviet Uzbekistan newspaper, July 8, 1976), A. Kayumov's“Adibva Arbob” (“Uzbekistan Culture” newspaper, August 31, 1976), N.Kobilov's“Taraqqiyparvarshoir” (“Uzbekistan Madaniyati” newspaper, August 27, 1976), F.Musamuhamedova's“Buyuksalafarizdoshi[Follower of the Great Salaf]” (“SovetUzbekistoni” newspaper September 5, 1976), V.Muminova's “Tarjimon [Translator]” (“Uzbekistan Madaniyati” newspaper, September 3, 1976), A.Akhmedov's “Komil-zullisonaynshoir” (“Adabiymeros”, 1983, №2), U.Khojaeva's “MuhammadniyozKomildevoniningToshkentnuxalari[Tashkent copies of Muhammadniyaz Kamil's divan]” (“Adabiymeros”, 1998, №3-4), R. Majidi's “KomilKhorezmi” (“Uzbektilivaadabiyotimasalalari”, 1961, №2), R. Khojiev's“KomilXorazmiy – xattotvashoir[KomilKhorezmi - calligrapher and poet]” (“Adabiymeros”, 1978, №11), Sh. Yusupov’s“Komilhaqidayangima’lumot[New information about Kamil]” (“Sharqyulduzi”, 1988, №7), F. Kabulov’s “Komilhaqidayanabiryangima’lumot[Another new information about Kamil]” (“Adabiymeros”, 1991, №2), various aspects of Kamil’s life and creative activity were explored. Moreover, In the fifth volume of the five-volume “History of Uzbek literature” by the literary critic A. Hayitmetov under the title of“MuhammadniyozKomil” was studied in detail the life and literary heritage of the poet [15: 65-96]. It seems that from the middle of the last century to the present day the life and work of Kamil Khorezmi have been studied in various aspects.

A relatively complete version of Komil's literary heritage is *Devon*, published in 1975 by literary scholars A. Hayitmetov and V. Muminova on the occasion of the 150th anniversary of the poet's birth. The publication includes about 3,800 poems of the poet, including lyrical genres such as ghazal, mustahzod, murabba, muhammas, musaddas, musabba, qasida, rubai, problema, bahritavil [6]. First of all, it should be noted that this edition contains a relatively large part of the lyrical heritage of Kamil Khorezmi in the current spelling. Although A. Hayitmetov noted that the poet's works were “published in a slightly abbreviated form”, it seems that most of the *devon* was not included in this edition. In particular, religious-mystical, enlightening poems, hymns, prayers and ghazals, poems on socio-political themes, continents based on history are not included in the publication at all. Only three ghazals are included from the poet's Persian heritage. However, manuscripts and lithographs of Kamil *Devon*, various bayoz and collections contain about twenty ghazals of the poet, three muhammas, eight histories, one of which is Persian poetry in the genres of musaddas and musamman.

The poet's office was published twice in his lifetime - in Khiva (1880, 1895), where the first lithographic printing house in Central Asia was established, and later in 1910 in Tashkent in lithography. Although all three editions do not fully cover Kamil’s lyrical legacy, they serve as an important source in the study of his work.

Until this, about a dozen manuscripts of Kamil's office have arrived, and they mostly complement each other. Among the manuscript sources, the 1949 and 1025 inventory digital copies kept in the manuscript fund of the Institute of Oriental Studies named after Abu RayhanBeruni are relatively excellent sources. Therefore, these two copies were selected as the base source for the 1975 edition of the *devon*.

During the period of independence, samples of Kamil's work were included in the textbooks of schools and secondary special educational institutions, information about the life and work of the poet was published in higher education textbooks.

It should be noted that the sources devoted to the study of the life and work of the poet are not without certain shortcomings and errors. For example, there is a difference in the sources about the name of the poet. A. Otamurodova and O. Abdurahimov in their article “Kamil Xorazmiy Matniyozdevonbegi emas” put forward the following ideas: “...In the literary criticism of that time, under the ideological persecution of the komfirka, some historical figures, writers and poets became “mature propagandists of advanced Russian culture.” was interpreted as a “hero” who applauded the Russian colonialists. In particular, during the tragedies of the conquest of the Khiva khanate by General Kaufman, the image of Matniyaz-Muhammad Niyaz devonbegi, who was benevolent to the colonialists, was distorted and confused by Pahlavon Niyaz Muhammad Kamil Khorezmi... His contemporaries called him “Matniyaz” in the form of “Muhammad Niyaz”. After all, Kamil Khorezmi's name was “Niyaz Muhammad”! His contemporaries never called him “Matniyaz”. Because in the Khorezm dialect Niyaz Muhammad is called “Niyozmat”. Muhammad Niyaz is called “Matniyaz”. The poet's name was Niyaz Muhammad, and in some sources, especially in music literature, he is referred to as Pahlavon Niyaz Muhammad. The word “Pahlavon” was a name given to him in his youth, and this name was preserved later. In historical books, the poet's name appears in the form of Matniyaz” [14].

In scientific sources on the life and creative activity of Kamil Khorezmi, the date of birth of the poet is indicated differently in the sources. Literary critic R. Majidi in the preface “Tanlanganshe’rlar [Selected Poems]” [7: 7] and in the article “Kamil Khorezmi” [9:25], in “Milliy uygonish davri uzbek adabiyoti [Uzbek literature of the National Awakening]” [10:33] also indicate the year of birth of the poet as 1897. In our opinion, the authors of the above sources relied on the data of Laffasi's work “Tazkiraishuaro”. Laffasi, a younger contemporary of Kamil, states that he died in 1315 AH (1897 AD) at the age of 72 [8:24]. The information in the “Musical History of Khorezm” that “he died in the morning on the 27th of Sha’ban 1317” is reliable. First, the date is clearly indicated in the next play. Secondly, one of the authors of the work, Muhammad Yusuf, the father of the devonzoda, Muhammad Yaqub, was a pupil brought up in the house of the devon Kamil Khorezmi. Accordingly, it would be correct to indicate the date of Kamil's death as the 27th of Sha’ban 1317 AH (December 31, 1899 AD).

## CONCLUSION

The life and creative activity of Kamil Khorezmi were studied not only in literature, but also in fiction. Drama “Night and Nails” by playwright Yu. Yusupov, Educational-artistic novel “Kamil Khorezmi” by Kamil Avaz were one of the commendable works in this field.

In general, although the life and work of Kamil Khorezmi are still being studied, there are some errors in the information provided. Correcting them on the basis of reliable sources, studying all aspects of the poet's life and work on a monographic scale is one of the urgent tasks of today's literature.

## REFERENCES:

1. Bayoniy. Shajarayi Xorazmshohiy. – Toshkent: Gafur Gulom nomidagi ASN, 1994.
2. Buxoriy, Shayx Sulaymon. Lugatchigatoyivaturkiusmoniy. Toshbosma. – Istanbul: 1298.

3. Ginzburg S.L. Komil Muzikalno-istoricheskoenasledstvasovetskogo Uzbekistana. Sbornik. "Putirazvitiya Uzbekskoy muziki", – Leningrad–Moskva, 1946.
4. Devoni Mavlono Komil maatavori xohon Xorazm. Toshbosma. UzRFASHarqshunoslik institutifondi, Inv. №237.
5. Karimov G. Uzbek adabiyotitarixi [History of Uzbek literature]. 3<sup>rd</sup> book. – Toshkent: Uqituvchi, 1975.
6. Komil. Devon. Prepared for publication: A. Hayitmetov, V. Muminova. – Toshkent: Gafur Gulom nomidagi ASN, 1975.
7. Komil Xorazmiy. Tanlangan she'rlar [Selected poems]. Nashrgatayyorlovchi: R. Majidiy. – Toshkent: Badiiy adabiyot nashriyoti, 1971.
8. Laffasiy. Tazkira shuaro. – Urganch: "Xorazm", 1992.
9. Majidiy R. Komil Xorazmiy. // journal of "Uzbek til va adabiyot masalalari [Issues of Uzbek language and literature]". 1961, №2.
10. Qosimov B. Et al. Milliy uyg'onish davri uzbek adabiyoti [Uzbek literature of the national revival period]. – Toshkent: Ma'naviyat, 2004.
11. Murodov A. Urta Osiyoxattotlik san'atitarixidan [From the history of Central Asian calligraphy]. – Toshkent: Fan, 1971.
12. Ogahiy Gulshanidavlat. Qulyozma. UzRFASHarqshunoslik institutifondi, Inv. 79.
13. Ra'nova Zebo. UzRFASHarqshunoslik institutifondi. Qulyozma. Inv. №883.
14. Otamurodova A., Abdurahimov O. Komil Xorazmiy Matniyozdevon begi emas // "Uzbekiston adabiyotivasan'ati" newspaper, 2011 yil 23 sentabr.
15. Uzbek adabiyotitarixi. 5 tomlik. 5-tom. – Toshkent: Fan, 1980.
16. Uzbek poeziyasining antologiyasi. – Toshkent: Uzdavnashr, 1971.
17. Hojiev R. Komil Xorazmiy – xattotvanoshir. // "Adabiymeros" jurnali. 1978, №11.



**ACADEMICIA**  
**An International  
 Multidisciplinary  
 Research Journal**  
 (Double Blind Refereed & Peer Reviewed Journal)

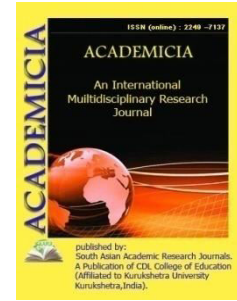

**DOI: 10.5958/2249-7137.2021.01976.5**

## METHODS OF THERAPY AND PROPHYLAXIS OF PYROPLASMOSIS AND TAYLERIOSIS OF LARGE CATTLE

**Duskulov Vohidjon Muhitdinovich\***; **Nasimova Dildora Rayimjonova\*\***;  
**Norkuziev Berdiyoy Bozorboy ogli\*\*\***; **Narzullaev Abbas Akram ogli\*\*\*\***

\* Assistant,

Department of Veterinary sanitary examination and hygiene Candidate of veterinary sciences,  
 Samarkand institute of veterinary medicine,  
 UZBEKISTAN

\*\*Assistant,

Samarkand institute of veterinary medicine,  
 UZBEKISTAN

\*\*\*Master,

Samarkand institute of veterinary medicine,  
 UZBEKISTAN

\*\*\*\*Master,

Samarkand institute of veterinary medicine,  
 UZBEKISTAN

### ABSTRACT

*In treating Piropilazmidoz disease of cattle it was defined the efficiency of uzbicarb applied per 3 mg / kg of cow's body weight. Effectiveness of the policarb preparation produced in order to prevent from theileriosis made 15 days, it was received 7.6 sums of economic benefits for the spent 1 sum. A large amount of work has been done to develop methods of struggle against ixodic ticks that are introduced into production. Simultaneously, there were conducted studies pyroplasmidosis causative agents of cattle and the search for means of struggle and prevention in these diseases.*

**KEYWORDS:** *Theileriosis, Pyroplasmosis, Prophylaxis, Diamidin, Uzbicarb, Polycarb, Berenil, Infection, Azidin.*

### INTRODUCTION



### Actuality

Among the invasive diseases pyroplasmosis, cattle theileriosis are the most insidious diseases, the causative agents of which are transmitted by the animals to certain species of pasture blood-sucking ticks. The study of these diseases was started from the first days of the organization of the institute. At the same time, the great attention of Native scientists was focused on the study of the fauna of ixodic ticks in the republic, the identification of ticks of carriers of pathogens of pyroplasmidosis of animals and the study of fauna and biology. A large amount of work has been done to develop methods of struggle against ixodic ticks that are introduced into production. Simultaneously, there were conducted studies pyroplasmidosis causative agents of cattle and the search for means of struggle and prevention in these diseases. Along with this, measures of struggle, diagnostics, therapy, special and chemical prophylaxis, control of the epizootic state of pyroplasmidosis were also developed and improved. Taking into consideration that such work is needed and necessary for the development of livestock, many domestic scientists have developed various ways and means against pyroplasmidosis of cattle. So, in 1936-1941 and 1946-1955 years, Head of the laboratory of protozoology, Professor A.V.Bogoroditsky established the therapeutic and prophylactic properties of the preparations of ihtargan, albargen, tripanblau, hemosporidin in pyroplasmidosis of cattle and introduced them into veterinary practice.

P.A.Lavrentev in 1956-1958 years studied the morphology, biology, immunobiological properties of the causative agents of pyroplasmidosis, developed a number of means and ways to struggle against these diseases.

In the period 1959-1965 years P.N.Lee and I.Kh.Rasulov approved the therapeutic and prophylactic properties of the drugs berenil, azidine, which they introduced into the production practice. This is a huge contribution of scientists, concerning the protection of animals from pyroplasmidosis.

The scientific activity of the staff of the laboratory of protozoology under the guidance of Professor T.Kh.Rakhimov (1969-1993) was directed to the study of epizootology of protozoan diseases of cattle, biology, morphology of pathogens and the development of means and methods of treatment. Based on the results of the research, methods of treatment with diamidin, ABP (acrichin + bigumal + plasmacid), delagilum, which have been introduced into veterinary practice, have been developed. After the independence of the Republic, all these developments and means lost their importance. Therefore, the need arose to create domestic antiprotozoal drugs in the Republic of Uzbekistan.

Scientists of the Faculty of Chemistry of the National University synthesized the antiprotozoal drug Uzbicarb (patent for invention of the Republic of Uzbekistan No. 1AP03933). Uzbicarb is an analogue of diamidin, which was previously produced in the Russian Federation, and then synthesized in our Republic.

Along with this, preparations of polyamidine, and then polycarb have been developed which have prophylactic properties in pyroplasmosis and teileriosis. The polymeric complex of polycarb (this is a conditional name) is a 4% solution of uzbicarb with an apple pectin:

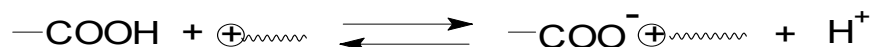

The antiprotozoal preparation of polycarb leads to deformation of the parasite, disrupts the metabolism, stops the synthesis of DNA. As a result, the life cycle of the parasite is disrupted.

### **The purpose of the research**

The study of the therapeutic and prophylactic properties of uezbicarb and polycarb in pyroplasmosis and the theileriosis of cattle.

### **Tasks:**

1. Study of the medicinal properties of uezbicarb in pyroplasmosis and theileriosis of large stock.
2. Study of the prophylactic properties of polycarb in pyroplasmosis and the theileriosis of cattle.
3. Conduction of production tests of polycarb.
4. Determination of economic efficiency.

### **Materials and methods of research**

Scientific-Research works on the study of the therapeutic properties of uezbicarb in pyroplasmosis was performed both in experimental and in production conditions. Under experimental conditions, the animals were infected with blood from spontaneously sick animals.

Before and during the experiments, the experimental animals underwent clinical and parasitological examinations. During the clinical examination, the body temperature, pulse and respiration rate were measured, the condition of visible mucous membranes, the presence of bloody urine, and the condition of the superficial lymph nodes were observed. For the detection of bloodparasites, smears were prepared from peripheral blood and the degree of erythrocyte involvement by parasites was determined. The smears were fixed with ethyl alcohol and stained using Romanovsky's method by Azur-Eosin.

### **Results of the research**

The study of the therapeutic efficiency of uezbicarb in pyroplasmosis under experimental conditions was carried out on 6 heads of experimental animals aged 10-12 months. The animals were infected with the invasive blood of pyroplasmosis.

Every day a clinical and parasitological study was carried out in the result of which on the 8th day after infection in the experimental animals appeared clinical signs of pyroplasmosis and parasitemia in the blood. After that, the experimental animals were divided into 2 groups in each of 3 animals.

1-group was treated with uezbicarb in a dose of 2 mg / kg of animals, and the second 3 mg / kg.

As a result, clinical and parasitological studies established that uezbicarb at a dose of 2 mg / kg of animal mass was not very effective, and at that time the use of a dose of 3 mg / kg was effective.

Production trials of uezbicarb were carried out on 14 spontaneously deceased with pyroplasmosis animals in the Umed-B farm of the Djizak region. Before treatment, the body temperature of animals was 40.4-40.6 ° C, the pulse and respiration rates were frequent, hemoglobinuria and depression were observed. In smears taken from the transfusion blood, 2-3% of erythrocyte involvement was detected by pyroplasm. Patients were subcutaneously injected with uezbicarb at a dose of 3 mg / kg. 24 hours after treatment, the condition of animals improved, body

temperature decreased to physiological norm, and in smears taken from peripheral blood, pyroplasm were not detected.

Consequently, the use of izardb in a dose of 3 mg / kg was accompanied by a pronounced therapeutic efficiency in pyroplasmosis of large cattle. Comparative studies of the therapeutic efficiency of izardb and the combination with buprolex in teilerosis were performed in 3 groups of animals in each of 3 heads. The animals were infected with blood taken from a spontaneously diseased animal body, subcutaneously in a dose of 10 ml.

After the appearing of clinical signs and parasitemia in the blood, the first group of animals was treated with izardb, a second with buprolex at a dose of 5.0 ml per 100 kg of live weight of animals and a third with buprolex in combination with izardb.

As a result of clinical and parasitological studies, it was found that the general condition did not change for the first group of animals in 2-3 days after the treatment, in the second group slightly improved, and in the third group the general condition improved, the parasitemia in the blood and body temperatures decreased to 40, 2 °C, there appeared an appetite and a chewing.

Therefore, izardb in the applied dose did not give a positive effect, buprolex gave weak and buprolex in combination with izardb gave expressed therapeutic efficiency (Table-1).

**TABLE-1 A STUDY OF THE COMPARATIVE THERAPEUTIC EFFICIENCY OF UZBICARB IN COMBINATION WITH BUPROLEX**

Group of animals	Number of animals	Method of treatment	Clinical condition and parasitemia on the first day of treatment	Clinical condition and parasitemia on the third day of treatment	Results
1	3	Uzbicarb in a dose of 3 mg/kg	General condition of the depressed, T <sup>0</sup> 40,6-41,0 parasite reaction 6-8%	The general condition is depressed, T <sup>0</sup> 40,6-41,0 parasitic reactions 6-8%	There is no curative effectiveness
2	3	Buprollex in a dose of 5.0ml per 100 kg of live weight of animals	General condition of the depressed, T <sup>0</sup> 40,6-41,0 parasite reaction 6-8%	The general condition slightly improved, T <sup>0</sup> 40.6-40.7 parasitic reaction 5-6%	Therapeutic efficiency is weak
3	3	Buprolex at a dose of 5.0 ml per 100 kg and Uzbicarb at a dose of 3 mg / kg of live weight of animals	The general condition is depressed, T <sup>0</sup> 40,6-41,0 parasitic reactions 6-8%	The general condition improved, T <sup>0</sup> decreased to 40.2 and the parasitic response to 3%	Therapeutic efficiency is expressed

Experiments on studying the prophylactic properties of polycarb in experimental pyroplasmosis and theilerosis were carried out in 2 groups of animals in each of 3 heads. Experimental animals of both groups were injected subcutaneously with 5.0 ml of polycarb per 100 kg of live weight of

animals. Then, after 15 days, the first group was infected with pyroplasmosis and 2nd with theilerosis. Within 30 days, daily clinical and parasitological studies were performed.

As a result of the conducted studies, it was established that the polycarb when modified based on uzbicarb with apple pectin has prophylactic efficiency for pyroplasmosis and theilerosis during 15 days (Table-2)

**TABLE 2 STUDY OF PROPHYLACTIC PROPERTIES OF POLYCARB IN PYROPLASMOSIS AND THEILEROSIS**

Group of animals	Number of animals	Method of prevention	Ways of infection	Results
1	3	Subcutaneously injected polycarb in a dose of 5.0 ml per 100 kg of live weight of animals	Infected with pyroplasmosis	Within 15 days after infection, the clinical and parasitic reactions of pyroplasmosis were not detected
2	3	Subcutaneously injected polycarb in a dose of 5.0 ml per 100 kg of live weight of animals	Infected with Theilerosis	Within 30 days after infection, the clinical and parasitic reactions of the theilerosis behind were not manifested

Thus, the preventive efficiency of polycarb in pyroplasmosis and theilerosis is up to 15 days.

Consequently, the application of polycarb with the preventive purpose of pyroplasmosis and theilerosis is advisable.

Experiments on the production test of polycarb were carried out in the Agroistiklol farm of the Kamashinsky district of the Kashkadarya region on 284 adult heads and 150 head of young animals.

The drug was applied every 15 days to 5.0 ml per 100 kg of live weight of animals. As a control, Dungsanchikul farms were used on which no drug was used (Table-3).

**TABLE-3 RESULTS OF THE APPLICATION OF POLYCARB IN PRODUCTION CONDITIONS**

Group	Economy	Heads	Epizootic state in 2015	Results of applying polycarb in the current year					
				April	May	June	July	August	September
Experimental.	Agroistiklol	434	Brought in February of 2016 from Australia	-	-	-	2 heads fell ill with theilerosis	-	-
Control	Dungsan	140	Twelve headaches	2 heads	2 headss	3 heads fell ill	5 heads fell ill with	1 head fell ill	-

	chuk ul		were caused by the disease, pyroplasmosis of 2 heads	fell ill with teilerosis	fell ill with Piroplasmosis	with teilerosis	teilerosis	with teilerosis	
--	------------	--	--	--------------------------------	-----------------------------------	--------------------	------------	--------------------	--

As a result of the production experience, it has been established that the polycarb used in every 15 days in active life of the tick mites has a pronounced preventive effect in pyroplasmosis and the theilerosis of cattle.

### CONCLUSIONS:

- the application of uezbicarb in a dose of 3 mg / kg has therapeutic efficiency in pyroplasmosis, and does not possess in the case of theilerosis;
- a one-time application of buprolix in a dose of 5.0 ml per 100 kg of live weight of animals has weak therapeutic effectiveness;
- the use of uezbicarb in a dose of 3 mg / kg and the combination of buprolix in a dose of 5.0 ml per 100 kg of live weight of animals has high therapeutic efficiency;
- the use of polycarb in a dose of 5.0 ml per 100 kg of live weight of animals prevents pyroplasmosis and theilerosis during 15 days;
- 99% of efficiency was obtained from the use of polycarb in production experiments and 7.6 sums of economic benefit was received for the spent 1 sum.

### USED LITERATURE

1. Gafurov A.G. Development of protozoological science in Uzbekistan. // Agriculture of Uzbekistan. 1999.-№ 3.-P.26-27.
2. Gafurov, A.G. The main results and prospects of scientific research on the study of epizootic situations, development of methods of therapy and prevention of protozoan animal diseases in Uzbekistan / A.G. Gafurov // Monitoring of the spread and prevention of especially dangerous diseases of animals and birds: Sat. Materials of the 4th international. Sci. Conf. - Samarkand, 2011. - P. 66-69
3. Karimov O. Pyroplasmidosis diseases of cattles. // U. U. Economical magazine, 2001.- No. 1, -P.58-59.
4. Turaboev N.J. Epizootic state of Pyroplasmidosis disease // Agriculture of Uzbekistan - Tashkent, 2001.-No. 4- P.62-63.
5. Seredkin V.A., Kasparov E.R., Usmanov U.S. Methodological recommendations for determining the economic damage from diseases of farm animals. // Samarkand. Taylak. 1994. - 132 p.
6. Shatokhin Yu.E. A technique for determining the economic efficiency of veterinary measures // M: MGAVMiB im. KI Skriabin, 1997. p.36.

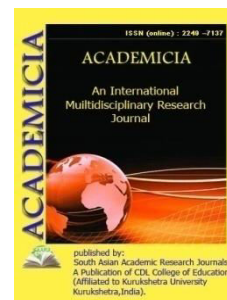
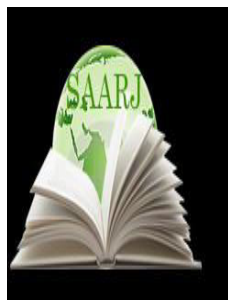

DOI: **10.5958/2249-7137.2021.01977.7**

## METHODS TO INCREASE THE PRODUCTIVITY OF IRRIGATED GRAZING SOILS

**Musurmanova Mohinur Murot kizi\***

\*Teacher of Gulistan State University,  
UZBEKISTAN

Email id: joniqulova95@mail.ru

### ABSTRACT

*This article discusses the methods of increasing the productivity of irrigated lands and their role in agriculture, and also the positive impact of these recommendations on the future development of agriculture in our country. The main task of reclamation measures of the new technology system is creating and maintaining optimal water, food and air regimes to ensure high and low yields of crops grown with efficient use of irrigation water and other sources. The period when the groundwater level raises the most corresponds to the periods of saline washing and vegetation irrigation. The level of mineralization of groundwater in this period is at its lowest.*

**KEYWORDS:** *Agrochemical Properties, Land Resources, Agro Physical, Different Climate, Soil-Climate, Land And Water Resources, State Cadastres, Pests, Digitization.*

### INTRODUCTION

Scientific researchers are being conducted in a number of priority areas such as further development of agriculture in the world, maintaining soil fertility, restoration, increase and efficient use of land resources, optimization of ecological condition, assessment of water-physical, technological, agrochemical properties and reclamation of lands in the current conditions. In this regard, special attention is paid to the development of agro-technical, agro-physical measures in accordance with soil and climatic conditions, improvement, restoration and increase of soil fertility, extensive use of scientific and practical achievements.

In the irrigated soil-climatic conditions of our republic, mainly cotton – plant, grain, field, vegetables and fruit crops are grown. Irrigated soils of Uzbekistan are distributed in different climatic conditions; their area is only 4280000 hectares, which does not fully satisfy the needs of the growing population. In order to satisfy the needs of the population, it is necessary to increase



the fertility of irrigated soils and the productivity of agricultural crops. This can only be done by creating and using new technologies.

Decree of the President of the Republic of Uzbekistan dated June 17, 2019 No PF-5742 “On measures for the efficient use of land and water resources in agriculture”, decree PF-5853 of October 23, 2019 “On approval of the Strategy of agricultural development of the Republic of Uzbekistan for 2020-2030”, decree PF-6061 of September 7, 2020 “On measures to radically improve the system of land accounting and state cadastre” and also Resolution of the Cabinet of Ministers of the Republic of Uzbekistan dated June 18, 2019 No 510 “On measures to improve the system of agrochemical analysis of soil in agriculture, increase soil fertility in arable land” to further strengthen food security in the country, increase the export potential of the agricultural sector, creation of new varieties of agricultural crops with high productivity, resistant to diseases and pests, adapted to local soil-climatic and ecological conditions, improving the system of agrochemical analysis of soil in agriculture, increase and maintain soil fertility in arable lands and its introduction into production, digitization of agriculture, the organization of research work on the application of new technologies in the field.

Targeted soil temperature control is one of the most important issues in soil science. One of the effective measures used to improve soil temperature is mulch, i.e. covering the soil with rotten manure, peat, paper, straw, polyethylene film, hay and coal dust, plant leaves, ash, sand, cement, wood chips, etc., this method raises the soil temperature and slows down the radiation cooling of the soil at night. Mulch is not only optimizes soil heat regime but also reduces physical evaporation from the soil surface and consequently increases soil moisture. Mulch prevents thickening that occurs after heavy rains in areas planted in early spring. In addition, mulch helps to the soil improves its agro physical, agrochemical, biological properties.

Nowadays, as a result of strong influence of anthropogenic factors on soils, their properties change dramatically. As a result, crop yields are much lower than planned in some districts. To date, the productivity of irrigated lands does not fully satisfy their needs. Therefore, increasing the level of soil fertility, creating a scientific basis for the efficient use of land and water resources, mineral and organic fertilizers determines the urgency of the problem.

The main task of reclamation measures of the new technology system is creating and maintaining optimal water, food and air regimes to ensure high and low yields of crops grown with efficient use of irrigation water and other sources. At the same time, the new technology should be aimed at increasing soil fertility in the reclamation system and eliminating the negative impact on the environment. In a special farming system for saline soils, this technology has not developed methods to prevent salinity and restore soil fertility. In this direction, it is necessary to develop a system of technologies that restore the natural state of the soil by alternating the cultivation of agricultural crops with the cultivation of tillage and the accumulation of organic matter on the surface of the pile.

Thus, due to the formation of optimal water-physical, nutrient regimes in the mulched soil, the environmental conditions are improved due to the negative impact of tillage machines and the reduction of emissions of smoke and dust into the environment. It provides high-tech and high-quality harvest, intensive growth, development and maturation of agricultural crops.

As explained above, the development of new technologies that restore the natural condition and increase the fertility of the soils of irrigated areas requires development. In this direction, a new

soil mulching technology system will be developed, which will restore the natural state of irrigated soils and increase soil fertility through the rotation of agricultural crops. In this farming system, tillage is done by alternating planting and mulching of agricultural crops. In this regard, a major problem for agricultural science needs to be solved. In this technology the soil is well supplied with moisture and nutrients. Through the pores of the aggregates, worm traces, rotten root cavities, etc., water, nutrients, air, and heat reach the layers where the roots of the plants are scattered. By leaving the vegetative parts of the cultivated crops on the soil surface every year, the maximum accumulation of organic matter leads to moisture retention, creating conditions for the proliferation of soil-dwelling animals and microorganisms. As a result of achieving a sharp reduction in tillage and tillage with the help of mechanization, the natural state of the soil is gradually restored, the ecological environment is stabilized

### **Hydrogeology and geomorphology of increasing soil fertility.**

One of the factors in the process of modern soil formation is hydrogeological conditions. The main sources of groundwater in the Mirzachul region are surface, groundwater and atmospheric precipitation. The all groundwater in the Syrdarya region moves slowly from south-east to north-west under a very small slope (0.0060). Secondary salinity of soils occurs as a result of upward water exchange or evaporation as a result of very slow natural movement of groundwater in the region. The strata of Mirzachul groundwater are crushed (quaternary) deposits with a thickness of up to 300 m, consisting of sandstones, mud, sandstones, sandstones and sometimes gravel [2.46; 266 page]. This was also due to the poor performance of the drainage system. There are many different saline soils in the region. Therefore, in the land resources used for agricultural purposes can be achieved only through the constant application of modern reclamation measures, mainly by cleaning the system of saline drainage ditches.

The groundwater level in the area varies according to water permeability and geomorphologic conditions, depending on the water supply at the current agricultural stage. In the eastern parts or on the terraces of the II-I ridges of the Syrdarya, they are located at a level of 1-2.5 m in the central part, 2-3 m above the sediments and depressions. The groundwater table is mainly located close to the surface, mainly in other parts of the Syrdarya and in the northern districts of the region.

The main source of groundwater is surface water, which is absorbed downstream from irrigation systems, and irrigation water from fields. The period when the groundwater level raises the most corresponds to the periods of saline washing and vegetation irrigation. The level of mineralization of groundwater in this period is at its lowest. At present, the river waters extend to I – terrace and terraces, as well as to the areas of grasslands in the north-eastern part of the region. Thus, the order and mineralization of groundwater in the area will be under the predominant influence of irrigation and human factors.

Studies have shown that due to insufficient management of surface and groundwater, they intensify the process of secondary salinity as a result of infiltration into the upper layers of the soil.

The process of hydromorphic (moist) soil formation is underway in the region at the current stage of agricultural farming. This is also due to the rising groundwater in many parts of the region.

The territory of the Syrdarya region occupies a large foothill plain, forming the main part of Mirzachul, which has a slope to the north, northwest, bordered by the Turkestan mountain range to the south and the Syrdarya River to the north, and the Kyzylkum Desert to the west.

The main part of the Syrdarya region is located in Mirzachul and the first information about its hydrogeology is found in the works of N.A.Dimo [2.46; 266p]. N.A.Dimo describes the genesis, salinity, mineralization, and depth of soils. He connects the origin of the lands in the eastern part of the region with the Syrdarya, and the lands of the western part with the proluvial origins of the Turkestan ridge. The wide plain of the region starts from the south-eastern corner and extends to the Kyzylkum desert, the lands of the central region are divided into a number of self-sufficient sediments and depressions.

### **Influence of anthropogenic factors on changes in soil properties.**

According to UNESCO, in the last quarter of the twentieth century, more than 9 million 2 km of land was degraded by human activities, which now accounts for 43% of the total land area. At the present time, 6/1 of the world's population suffers from desertification.

The active influence of man on the nature of the region can be attributed to the development of light industry-increasing demand for agricultural crops. In this regard, the construction of canals, irrigation and collector-drainage networks led to the technical re-formation of the area, to some extent disrupted the connection with natural landscape components and caused the problem of protection of soil layers and flora.

In order to keep irrigated lands in a favorable reclamation condition, several tens of thousands of kilometers of farms have built internal and inter-farm collector-drainage networks. However, the imperfection of hydraulic structures, often the low level of their use and the lack of the necessary science-based irrigation and saline washing systems have led to changes in natural conditions in irrigated areas, rising groundwater.

As a result of regular irrigation, the acceleration of the development of new types of hydromorphic soils, the regular application of organic and mineral fertilizers to the soil led to the formation of new soils that differ in their properties from the previous natural soils. As a result, salinity processes took place, its evolution accelerated, leading to changes in soil structure.

Irrigation has a significant impact on soil processes, increasing soil moisture and bringing with it various substances dissolved in water. Prolonged and irregular irrigation of lands has led to a radical change in water and salt regimes in the soil. In addition to allowing plants to grow well due to increased humidity, gypsum, carbonates accumulate in the soil and are enriched with easily and difficult-to-dissolve ( $\text{CaCO}_3$ ,  $\text{MgCO}_3$ ) salts as a result of redistribution of water-soluble salts. In addition, the impact of irrigation water affects the compaction of irrigated soils, as well as the air in the soil surface layer.

Expansion of engineering and geological prospecting works in the region, the emergence of new irrigation networks, aimless earthworks of various sizes, plants that hold the soil firmly, cutting of shrubs and semi-shrubs, grazing of cattle wherever they want, etc. cause the topsoil cover of soils with light mechanical content to fly away and as a result erosion processes occur, expanding the deflation zone.

Increasing salinity and defoliation processes are causing irreparable damage to agriculture in the region, which in turn requires scientists and specialists to reconsider the issue of proper use of land resources.

### Experimental systems and methods

Field experiments were conducted on the basis of field experiments in the conditions of irrigated gray-grass soils. Field experiments were conducted in the conditions of irrigated gray meadow soils on the basis of methodological manuals of the Uzbek Institute of Cotton, Soil Science and Agro chemistry. Field experiments were conducted according to the following scheme:

1. The land was plowed + flattened chisel, storms and showers + garden – bed was taken + seeds were planted, amount of mineral fertilizers - N-250, R-175, K-125 (control).
2. Do not plow, loosen the surface of the pre-obtained garden – bed+ seeds were planted on the garden – bed+ mulched with crushed straw- N-250, R-175, K-125.
3. Do not plow, loosen the surface of the pre-obtained garden – bed + seeds were planted + mulched with lignin + the amount of mineral fertilizers - N-250, R-175, K-125.
4. The surface of the uncultivated garden – bed is softened seeds were planted + mulched with rotten manure-N-250, R-175, K-125.

Field experiments were carried out on the basis of fertilizer standards and agro-techniques adopted on the farm in accordance with our purpose.

The area planted with cotton – plant							
I – returning				II – returning			
1. control	2. cut straw	3. lignin	4. manure	1. control	2. cut straw	3. lignin	4. manure
III- returning				IV- returning			
2. cut straw	1. control	4. manure	3. lignin	2. cut straw	1. control	4. manure	3. lignin

### In summary:

1. In the conditions of irrigated gray-grass soils, plowing was the most difficult measure, and leveling the plow required a lot of work and money. In early spring, the soil had a good structure, and preparing it for planting according to the new agro technology made it easier to mulch the seedlings in the areas where the seeds were planted. Correction of sprouts in accordance with agro requirements can be of plow less quality in the studied areas. Mulching and partial plowing during the growing season allowed agricultural crops to maintain the optimum soil density at the optimum level of 1.38-1.39 g / cm<sup>3</sup>.
2. Nutrients (nitrogen, phosphorus, potassium) were well absorbed by the plant when mulched with organic residues in the soil in which cotton – plant was grown, and the amount of humus in the soil increased (by 0.6-0.9%). The use of soil nutrients by the plant in the cultivation of cotton mulch depends closely on the norms and types of organic fertilizers applied as mulch. When soils are mulched with various organic substances, the plant absorbs a lot of nutrients.

3. As a result of poor cultivation of mulched cotton, the ecological environment has improved due to the formation of optimal water-physical, nutrient regime in the soil, reduction of dust formation of soil tillage machines and toxic gases emitted from them. Intensive growth, development and increase in productivity of agricultural crops - 2.6-3.5-4.1 ts / ga, compared to the control in the mulched variants in cotton - yielded additional yields.

### **RECOMMENDATIONS FOR MANUFACTURING**

In order to obtain cheap, high-quality, stable and high yields of agricultural crops from irrigated lands, it is necessary to introduce a system of crop rotation and intermediate crop rotation by mulching the soil in the complex agro-technical measures. One of the most promising methods in the future is the cultivation of agricultural crops by mulching and mulching the soil surface with cultivated plant residues.

### **LIST OF REFERENCES:**

- I. Normative-legal documents and publications of methodological significance
  - 1.1. Mirziyoev Sh.M. Decree PF-4947 on the strategy of further development of the Republic of Uzbekistan. Tashkent, 2017. Chapter 3.1.
  - 1.2. National Report on the State of Land Resources of the Republic of Uzbekistan. Tashkent: State Committee for Geodesy and Cadastre, Tashkent 2012. -93 p.
  - 1.3. National Report on the state of the environment and use of natural resources in the Republic of Uzbekistan. -Tashkent. 2008. 31 p.

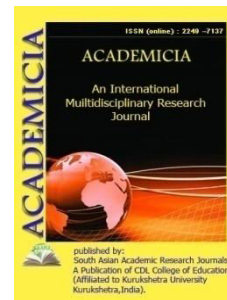
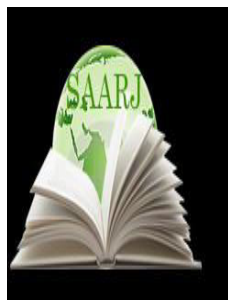

DOI: **10.5958/2249-7137.2021.01978.9**

## PHYTONYMIC COMPARISON AS A MEANS TO CREATE IMAGE IN POETRY

**Djalilova Zarnigor\***

\*Teacher of English literature and stylistics department,  
Bukhara State University,  
UZBEKISTAN  
Email id: afifa.zarnigor@gmail.com

### ABSTRACT

*The purpose of current work is to analyse figurative comparison containing phytonymic vocabulary in English poems. The term phytonym is defined as well as, the difference between simple and figurative comparison is explained. Examples from poems are brought to support discussion. This kind of comparison do not contain evaluative manner, but targets to compare closely related objects to establish similarities or differences between them. As an object of comparison in English poetry the lexicon of the thematic groups such as “Woman” and “Feelings” is presented.*

**KEYWORDS:** *Phytonym, Figurative Comparison, Poetry, Connotative Meaning.*

### I. INTRODUCTION

In the language and speech of every nation in the world there are onomastic units with nominative, communicative and stylistic functions representing phytonyms (flowers and plants), reflecting the integration of linguistics with the natural sciences, the connection between society and nature. In linguistics there is a strong interest in the study of linguistic units representing plant species and varieties - phytonyms as a linguistic expression of agriculture, while in literature there is great interest in the symbolic, metaphorical expression of images of flowers and trees.

From ancient times men felt themselves as a part of nature. Undoubtedly, in the early stages of human development, its existence depended on the plant world in every way. In their interactions with nature, men gave plants names based on their distinctive features and perceptions of them.[10,4] According to I. Konovalova, these names form a separate lexical-semantic group - phytonymic lexicon, which performs not only nominative, but also pragmatic, evaluative,



expressive and other functions.[11, 235] Looking at the history of the study of phytonyms, it can be seen that it is a neologism that emerged as a term in the 1970s.[13, 343] The first research on phytonyms was conducted by A.V. Superanskaya, according to which "phytonym" is an individual name given to each plant, and "phytonomy" (in some sources "phytonymics") is defined as a part of the science of onomastics, which studies proper nouns.[15, 189] According to the author, the objects of the plant world should be studied as an independent field of research because they are closely related to the beliefs and traditions of different periods.[15, 186] F.I. Buslaev studied phytonomic lexicons from the cultural point of view, noting that the names of plants are associated with the spirit and culture of a particular people.[2,17]

The use, origin, and symbolic meanings of plants in poetry in English literature have been studied by J.Ingram, E.F.Hulme, F.Shoberl, and others.

## II. MAIN PART

V.V. Kopocheva in her work "Sootnoshenie iskusstvennoy i estestvennoy nominatsii (Na materiale nazvaniy rasteniy)" studies phytonyms from a motivational aspect. The author first grouped plants according to specific objective aspects such as shape, color, size, smell, taste, and groups according to relative features such as local characteristics, time of plant's activeness, and its effects on humans and animals.[12, 255] In the literature, especially in poetry, when the plant world is used to describe a person, it is observed that the analogy between objects is based on one or more of the features listed above.

It is important to note that from the point of view of semantics, comparison can be divided into logical and figurative. In stylistics, the former referred as ordinary comparison while the later simile, a stylistic device. [6, 166]Comparative logical constructions explain an unidentified object or action by a similar phenomenon. This kind of comparison do not contain evaluative manner, but targets to compare closely related objects to establish similarities or differences between them. For instance, *the boy was smart like his father*. Performing an explanatory function logical comparatives are directed to the mind and therefore are characterized by clarity and unambiguousness in meaning.

The second type of comparisons draws a vivid image of an object, action, state by comparing it with another object, action, state. In this case, there is not only the transfer of information, but also an emotional impact on the addressee, for example: "Her skin was like a grape". According to V.M. Ogoltsev, figurative comparative constructions are widely and intensively used in the process of verbal communication. [9, 5] The scientist divides this group into national (stable) comparisons and individually creative (free).Galperin calls them as triet and genuine similes.[6, 167]

Of greatest interest are phytonymic figurative, individually-creative constructions containing phytonymic vocabulary as the subject of comparison, which, unlike logical comparisons, "are always original, contain an element of novelty, they are one of the most individualized elements in the work of a particular writer or poet". [1,22] When phytonym becomes the subject of construction, consideration of all concepts of plants, their structure, properties, colors, nature of growth, etc., reflected in the comparisons of the author.

Frequent examples of figurative comparisons in English poems can be observed throughout different centuries and periods, especially when popular plants are used. As an object of

comparison in English poetry the lexicon of the thematic groups such as “Woman” and “Feelings” is presented. Characterizing a woman, various parts of her body, especially her face, lips and cheeks by phytonyms is widely used combinations. The object of phytonymic comparisons in the lexical-thematic group “Women” represent concepts both about females in general and about a specific person.

### III. DISCUSSION

In his poem Henry Chettle compares his beloved to daffodil. As Britannica tells daffodils are also called **common daffodil** or **trumpet narcissus**, bulb-forming plant in the amaryllis family, widely cultivated for its trumpetlike flowers. Daffodils are native to northern Europe and are grown in temperate climates around the world. The daffodil’s popularity has resulted in the production of many varieties; in addition to the classic yellow form, the trumpet and petals may themselves be of contrasting yellow, white, pink, or orange.[17] F.I.Hulme in his book “Bards and Blossams” defines this flower s following “The botanical name of the daffodil is *Narcissus pseudo-narcissus*, which may be freely translated as being the plant that is like the narcissus, but is not the narcissus itself, the more celebrated flower of the poets”.

Diaphenia, like the daffodowndilly,

White as the sun, fair as the lily,

Heigh ho, how I do love thee!

I do love thee as my lambs

Are beloved of their dams;

How blest were I if thou wouldst prove me [7, 172]

In order to understand why the poet is calling his beloved by this certain flower, we closely learned it. The generic title alludes to the classic myth of Echo and Narkissos. Echo was a beautiful nymph of the woods and hills, while Narkissos was the son of river-god Kephissos. She fell in love with Narkissos and transferred her regard to him, a regard which he, from most exaggerated ideas of his own worth, did not return. Echo in her grief pined away whereas Narkissos, whose main occupation was to wander by the brink of some clear stream that he might gaze on his charms, was changed by indignant gods into a flower, the flower that yet bears his name, the *Narcissus poeticus*, or narcissus of the poets.[8, 84] That is why poets have taken this flower as an emblem of unrequited love or pains from unreturned love. Reading the whole poem one can realize that Diphenia is like daffodil self-loved. In the second line the girl’s skin is associated with lilies. Obviously, the comparison between skin and the flower is based on colour and texture.

In the second stanza the author resembles the girl to “the spreading roses” and highlights her sweet smell. Ancient Greeks considered this flower as Gods’ gift to people. According to information brought by Anacreon, rose appeared from the sea foam that covered Aphrodite, the goddess of love, when she was coming out of water. Other Gods were so enchanted by the flower’s beauty that could not help themselves from sprinkling the roses with divine nectar. Thus, the rose gained its unique smell which has always been one of the most pleasant.

The circle of comparison objects receiving phytonymic characteristics in English poets' works is unusually wide. Cheeks of women are often compared to plants such as "apples and roses" as they are similar in colour, shape and texture. As it is known, author is describing not make-up but natural redness of the human cheeks which represents healthy body.

Her cheeks lyke apples which the sun hath rudded,[7,69](from Epithalamion by Edmund Spenser)

Her cheeks like rose and lily yield forth gleams,[7,100] (from Samela by Robert Green)

Rarely, relying on similarity of colour, cheeks are compared to "cherries", since they are usually associated with lips. Cherries come in pairs joined in a bud and like lips have thin skin, when bitten flesh like substance comes out reminding red blood from bitten lips.[3]

Her cheeks were like the cherry,[7,234](I Loved a Lass by George Whither)

Her lips lyke cherries charming men to byte, [7,69](from Epithalamion by Edmund Spenser)

Lips are also frequently characterized by rose or rose bud. Poet Thomas Campion describes his beloved's smiling image as "rose-buds filled with snow" referring to her red lips and white teeth.

Those cherries fairly do enclose  
Of orient pearl a double row,  
Which when her lovely laughter shows,  
They look like rose-buds filled with snow;[16]

There are also cases when the whole poem is built on comparison. One of this kind of poems is "To the Most Fair and Lovely Mistress, Anne Soame, now Lady Abdie" by Robert Herrick. In the poem one can witness the series of phytonyms for characterizing mistress's beauty and her fragrance.

So smell those adours that do rise  
From out the wealthy spiceries;  
So smells the flower of blooming clove,  
Or roses smother'd in the stove;  
So smells the air of spiced wine,  
Or essences of jessamine;

If paid attention, the flowers chosen in the poem, clove, rose, wine, and jessamine are popular for their strong fragrance. Therefore, clove, rose and wine are used in vining to give delighting smell and taste. As it is noted in the sources, one can find following description for cloves "they were also called clove-gelliflowers, from their perfume resembling that of the spice so called, and sops in wine, because they were on that account frequently used to flavour dainty dishes, as well as wine and other liquors".[14, 138] Rose petal wine captures the delicate floral aroma of fresh rose petals in a wine that's light and fresh, perfect for summertime sipping. And when it comes for wine, this plant was the most important ingredient for making this special drink. Since jessamine was not native in England and was brought from India, its value was high. As a result it was

widely used for making perfumes. Robert Herrick depicted these flowers to tell not only how sweet the mistress smelled, but also denote her beauty.

#### IV. CONCLUSION

Coming up from analysis, it can be noted that examples of comparative constructions clearly illustrate the basis comparisons; most often it is the color, shape, properties of plants. For figurative characteristics of notions such as women and feelings, the vocabulary of the following groups of phytonymic names are used: 1) general designation of plants (flower), names of fruit (cherry, apple), names of flowers (daffodil, lily, rose) and names of plant parts - partitive phytonyms (branch, leaf).

#### REFERENCE:

1. Artemenko E.P., Sokolova N.K. On some methods of learning the language of works of art. - Voronezh: Publishing house of Voronezh University, 1969 - C 22
2. Buslaev FI Historical sketches of Russian folk literature. M.: Book House "LIBROKOM", 2011.426 p.
3. Djalilova, Z. B. (2020). Flora in Edmund Spenser's poetry. *ISJ Theoretical & Applied Science, 04 (84)*, 371-375.
4. Djalilova, Z., & O'rayeva, D. (2021). Description Of Love And Life Through Flora In English Poetry Of The Xx Century. Center For Scientific Publications (buxdu.Uz), 1 (1). Retrieved from [http://journal.buxdu.uz/index.php/journals\\_buxdu/article/view/687](http://journal.buxdu.uz/index.php/journals_buxdu/article/view/687)
5. Djalilova, Z. (2021). Flowers Symbolizing Human Features In English Romantic Poetry. Center For Scientific Publications (buxdu.Uz), 1 (1). Retrieved from [http://journal.buxdu.uz/index.php/journals\\_buxdu/article/view/689](http://journal.buxdu.uz/index.php/journals_buxdu/article/view/689)
6. Galperin, I.R.(1977). Stylistics. Moscow: Higher school.P-167
7. Gardner, H. (1985). The New Oxford Book of English Verse. Oxford: Oxford University Press. 974 p.
8. Hulme, F.I. (1877). Bards and Blossoms or the Poetry ,History, and Associations of Flowers. London: MARCUS WARD & co.P-84
9. Ogoltsev V.M. Dictionary of stable comparisons of the Russian language. - M.: Russian dictionaries: AST: Astrel, 2001-C 5.
10. Konovalova NI Folk fitonymy as a fragment of the linguistic picture of the world. Ekaterinburg: Publishing house of the Teacher's House, 2001.150 p.
11. Konovalova NI Dictionary of folk names of plants in the Urals. Yekaterinburg: UrGPU, 2000.235 p.
12. Kopocheva V.V. The ratio of artificial and natural nomination (on the material of plant names): Dis. ... Candidate of Philol. sciences. Tomsk, 1985. 255 p.
13. Shansky NM, Bobrova TA School etymological dictionary of the Russian language: The origin of words. Moscow: Bustard, 2002.400 p.
14. Shoberl, F.(1948). The language of flowers. PensylvaniaP-138

15. Superanskaya AV General theory of proper name. Moscow: Nauka, 1973.366 p.

16. . <https://www.poetryfoundation.org/poems/50324/cherry-ripe>

17. <https://www.britannica.com/plant/daffodil>

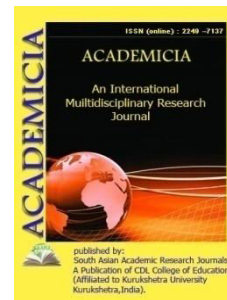
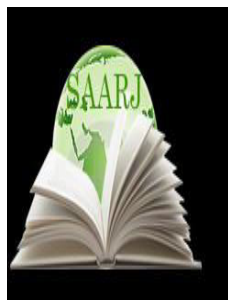

DOI: **10.5958/2249-7137.2021.01979.0**

## THE ROLE OF EXCURSIONS TO SPIRITUAL PLACES IN THE DEVELOPMENT OF THE SPIRITUALITY OF THE YOUNGER GENERATION

**Utanov Utkir Kurbanovich\***

\*Associate Professor of the Samarkand Regional,  
Doctor of Philosophy in Pedagogical Sciences (PhD),  
Center for Retraining and Advanced Training of Public Educators,  
UZBEKISTAN

Email id: [utanovutkir79@gmail.com](mailto:utanovutkir79@gmail.com)

### ABSTRACT

*This article explores the role and importance of our national-spiritual heritage in the development of the spirituality of the younger generation. In addition, the article describes the content of the organization of excursions to the places of spirituality in Samarkand and Samarkand region, it is organized as a result of scientific research.*

**KEYWORDS:** *Spirituality, Enlightenment, Heritage, Excursion, Excursion Facilities, Activities, Madrasa(A Traditional Islamic School), Mausoleum, Mosque, Museum, Theater.*

### INTRODUCTION

President of Uzbekistan Shavkat Mirziyoyev chaired a video conference on January 19, 2021 on radically improving the system of spiritual and educational work, strengthening cooperation between state and public organizations in this regard our President said that: "If the body of a society's life is the economy, its soul and spirit is spirituality". As we decide to build a new Uzbekistan, we will rely on two solid pillars.

The first is a strong economy based on market principles.

The second is the rich heritage of our ancestors and a strong spirituality based on national values.

Our esteemed President said that: "If someone thinks that the issue of spirituality is only the work of the Spirituality Center or the relevant ministries and departments, it is a mistake. All this is one of the most important tasks before us".



Such attention of the head of our state to the issues of spirituality and enlightenment is a requirement of the state and society for education today, increasing the spiritual and moral potential of the next generation in the interests of the nation, through which they demand that they not spare their productive labor for the destiny and future of the Motherland.

To do this, the formation of spiritual and moral qualities in the minds of the younger generation, in the process, every citizen should fully understand his social duty, being socially active, be able to react to events around him, be able to reconcile personal interests with national interests, he must be able to put the interests of the people before personal interests.

So the issue of spirituality is everyone's business. There is no break in education, our people say. But the continuity in spiritual-enlightenment work is not yet perfect. Kindergarten, school, higher education, neighborhood are each working on this issue. Therefore, the creation of a single system of spiritual and educational work, in particular, it is important to bring up the young generation in an educated and positive manner from an early age, for which the development of cooperation between preschool education, school, higher education, community.

Excursions to historical monuments and spiritual places have unlimited opportunities in all types of continuing education system, MTT, general secondary schools, secondary special education, higher education, strengthening, deepening the knowledge of the younger generation in the community and raising their spirituality.

This means that excursions to historical, architectural and cultural monuments will help our youth to learn about the human development of our great ancestors, in particular, the great contribution of the Uzbek state to the development of religious and secular sciences, spirituality and enlightenment, the magnificent monuments (madrasahs, observatories, mausoleums, etc.) built by them, to arouse and strengthen national pride in their hearts by introducing them to museums of local lore, color and image galleries, etc. It is inevitable that they will yield effective results in the development of noble goals, such as love for the Motherland, service to it, the pursuit of spiritual heights, and, ultimately, a healthy spiritual need.

Sheikh Yusuf Hamadoni, who found eternal peace in our sacred land, said that the Islamic world, mysticism and Sufism played a great role in our national ideology and at the same time his disciples are the pir of the Khojagon, Yassaviya and Kubraviya sects such as Abdukholik Gijduvani, Ahmad Yassavi, Najmiddin Kubro, Bahauddin Nakshband, Sheikh Khovand Tokhur, Khoja Ahror Wali, and to propagate to the youth that our Motherland is extremely influential in the Islamic world through our world-famous ancestors, thus demonstrating that Islam is an expression of peace, enlightenment, and high morality in order to develop the spirituality of young people, the work, which requires a strong light of thinking, along with the will and passion of the younger generation, was first launched in Samarkand, later, madrasahs, mausoleums, ensembles, cemeteries, mosques, sacred places where our saints rested forever, the shrines of our great scholars can be involved in the study of the Samarkand region.

More than four thousand material and spiritual monuments located in the territory of our country are included in the UNESCO list as a unique example of the world heritage and due to the fact that most of these unique historical monuments are located in the city and region of Samarkand, in order to effectively use them in the development of the spirituality of young people in the educational process, it is necessary to group them on the basis of certain characteristics.

During the years of independence, many new cultural, artistic and sports facilities have been built in the country, including in the city and region of Samarkand, considering that material and spiritual values are restored and serve to raise the spirituality of our people, especially the youth, the grouping of spiritual centers in Samarkand and the region is important.

Below we list the names of places of spirituality that have been systematized as a result of our research. It contains information about the excursion objects included in each group.

1. **Madrasas:** Ulugbek Madrassah, Yalangtosh Bahodir Madrassah, Tilla Kori Madrassah, Sherdor Madrassah and others.
2. **Mausoleums:** Guri Amir Mausoleum, Imam Motrudi Mausoleum, Mahdumi Azam Mausoleum, Imam Ismail al-Bukhari Mausoleum and memorial complex, etc.
3. **Mosques:** Bibihanim, Hazrati Hizr, Khoja Ahror Wali, Khoja Abdu darun, Khoja Abdu berun and others.
4. **Cemeteries:** Shahi Zinda, Chokardiza, Punjab, Saint Murad, etc.
5. **Places:** Amir Temur shrine, Mirzo Ulugbek shrine, Alisher Navoi shrine, Memorial Square, Mahmudkhoja Behbudi shrine (SamPXMOQTI).
6. **Museums:** Afrosiab Museum-Reserve, Afrosiab History Museum, Museum of History of Uzbekistan, Museum of Local Lore, Mirzo Ulugbek Observatory and Museum, Alisher Navoi Museum at Samarkand State University, Department of Old Manuscripts at the Samarkand State University Scientific Library, Museum of Geology at Samarkand State University, Museum of Zoology at Samarkand State University, Samarkand State University Museum of Archeology, Sadriddin Ayni House Museum, Museum of the Institute of Architecture and Construction named after Mirzo Ulugbek and Saidrizo Alizoda House Museum and others.
7. **Theaters:** Theater named after Hamid Olimjon, Theater named after A.Chekhov, Puppet Theater named after Asror Juraev, Amphitheater in the park named after Alisher Navoi.
8. **Concert halls:** a new concert hall at the Samarkand College of Arts on Mirzo Ulugbek Street, a concert hall at the Kamolot Youth Movement Center.
9. **Parks:** Alisher Navoi Park, Sogdiana Park, Youth Park.
10. **Information resource centers (libraries):** Pushkin Regional Information Resource Center, Information Resource Center named after Abdurahmon Jami of Samarkand State University, Samarkand State University (faculties of pedagogy and physics) information resource centers, Samarkand Institute of Foreign Languages Information Resource Center, Samarkand Agricultural Institute Information Resource Center, Information Resource Center of Samarkand Institute of Construction and Architecture, Information Resource Center of Samarkand Medical Institute, Information Resource Center of TUIT Samarkand branch, Information Resource Center of SamVPKMOQTI, Regional Children's Information Resource Center named after Abu Rayhon Beruni (62 M. Kashgari Street), etc.
11. **Workshops:** Crafts Center on Tashkent Street in Samarkand (former "Master Union"), "Temirchilik" workshop located in Siyob market. (Workshops of world-famous masters of pottery, knife-making, pottery.)

**12. Centers:** Samarkand Youth Center, Mashhura Training Center, Samarkand Crafts Center (former “Master Union”).

Through the results of our research, young people are encouraged to take into account such facilities in Samarkand, which testify to the high level of our spirituality, in accordance with the compilation of lists of historical monuments and their location in the territory of the city of Samarkand (streets and neighborhood), on the basis of the geographical map of Samarkand the methodical manual “Importance of excursions in development of spiritual competence of pupils” is published.

The guide includes places for organizing excursions to spiritual places, organized as a result of our research, a list of literature on the purpose of the tour, the plan, the independent work of young people during the tour and the study of sources related to the tour site. In addition, information about the excursion facilities included in each group is described.

In conclusion, the process of organizing excursions to the above-mentioned spiritual places will strengthen the attention of our youth to our national and spiritual heritage during the years of independence. By informing the younger generation about the huge creative work being done in this area, it serves to strengthen the love for the Motherland, the enhancement of historical memory, the sense of involvement in the noble deeds aimed at ensuring peace, prosperity and interethnic harmony in our homeland.

#### **LIST OF REFERENCES:**

1. Speech at a video conference chaired by the President of the Republic of Uzbekistan Shavkat Mirziyoyev on January 19, 2021 on the issues of radical improvement of the system of spiritual and educational work, strengthening cooperation between state and public organizations in this regard. *Hürriyet newspaper*. January 20, 2021.
2. The concept of continuous spiritual education. December 31, 2019.
3. Kosimova O. Technology of development of national spiritual and moral qualities of students: Doctor of Philosophy in Pedagogical Sciences. ... Diss. - Samarkand, 2020. - 141 p.
4. Utanov U. The role of excursions in the development of students' spiritual competence. - T.: “Qamar media”, 2021. 75 p.



**ACADEMICIA**  
**An International  
 Multidisciplinary  
 Research Journal**  
 (Double Blind Refereed & Peer Reviewed Journal)

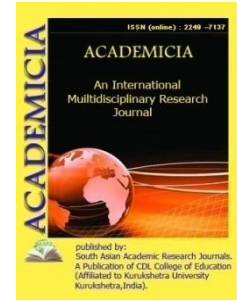

**DOI: 10.5958/2249-7137.2021.01980.7**

## **TREATMENT METHODS FOR GENERALIZED CANDIDA-ASSOCIATED PERIODONTITIS (LITERATURE REVIEW)**

**Avezova Salomat Mahmudjonovna\***

\*Assistant at the Department of Physiology,  
 Bukhara State Medical Institute,  
 UZBEKISTAN  
 Email id: [avezovasalomat49@gmail.com](mailto:avezovasalomat49@gmail.com)

### **ABSTRACT**

*The article provides modern data on the problem of etiology, pathogenesis, clinical picture and treatment of generalized periodontitis. Periodontitis is a multifactorial disease. However, the course and progression of periodontitis is influenced by a large number of factors, including local, systemic, social, genetic. Modern research shows an increase in the incidence of generalized periodontitis with candidal infection of the oral cavity. This question opens up new interest in the tactics of treating candida-associated periodontitis.*

**KEYWORDS:** *Generalized Periodontitis, Candida-Associated Periodontitis, Local And Systemic Therapy, Complex Treatment Of Diseases.*

### **INTRODUCTION**

Periodontal disease is a socially significant problem due to the widespread prevalence and intensity of damage to all age groups of the population. Approximately 50% of the population of different regions of the world at the age of 17-60 years have various forms of periodontal disease. Moreover, almost 90% of the population in developed countries are hereby ptomu gingivitis, 50% diagnosed generalized periodontitis (GP) moderate, and 3% severe. It should be noted that the incidence of periodontitis, including HAP, according to the World Health Organization, is widespread among people aged 30 to 40-44 years (55-98%), as well as at the age of 15-19 years (55-89 %)[1,3,5].

Failures of conservative treatment of chronic generalized periodontitis may be associated with the presence of fungal flora in the periodontal tissues [3,8]. The prevalence of Candida-associated periodontitis according to different authors is from 10 to 62% [3,12].

Colonization by the fungal flora of the biotope of the periodontal pocket is accompanied by the formation of mixed mycoceiasis, suggesting synergism with a number of opportunistic bacteria with a deficiency of normal microflora[9,10]. Between fungi and bacteria-associates, bilateral stimulation of growth and reproduction occurs, as well as mutual enhancement of virulence, which, under conditions of deficiency or elimination of normal flora, leads to the selection of resistant strains. This explains the resistance of periodontitis associated with Candida flora to traditional treatment [3,12].

Currently, there are many antiseptic preparations of different chemical groups with the declared antifungal activity on the pharmaceutical market [3,5].

The problem of choosing the correct treatment tactics is also associated with the difficulties of timely diagnosis of periodontitis associated with fungal flora, due to the absence of pathognomonic symptoms [2,8]. The search for a simple, fast and affordable method for predicting the presence of candida flora in the biotope of periodontal pockets is still relevant. Determination of the risk of contamination of periodontal tissues with Candida fungi, as well as microbiological verification of the alleged diagnosis are necessary for the doctor to prescribe adequate etiotropic therapy as part of the complex treatment of patients with candida-associated periodontitis [11].

It was found that in patients with candida-associated periodontitis strains of opportunistic bacteria are characterized by more pronounced resistance to antibacterial drugs. When studying the sensitivity of fungi of the genus Candida spp. to antifungal drugs, it was found that with a high degree of contamination, fungi are more resistant to their action. The presence of fungi of the genus Candida spp. and the degree of contamination by them is the basis for the choice of antiseptic drugs used as part of the basic therapy of chronic generalized periodontitis, while the most effective way to use an antiseptic is to affect the entire oral cavity. If we arrange antiseptics in descending order of their effect on the normalization of clinical and microbiological indicators, then we get the following chain: chlorhexidine 0.2% - hexetidine - chlorhexidine 0.05% - cetylperidine chloride - miramistin. The presence of Candida flora in the biotope of the periodontal pocket is associated with a deficiency of representatives of normal flora, the predominance of bacteria of the Candida-associated microflora group and a decrease in antibiotic sensitivity of opportunistic bacteria. The sensitivity of fungi to antimycotics is lower with a high degree of contamination by them[7].

The complex treatment of candida-associated periodontitis, including an antibacterial drug, the administration of natamycin orally and topically in combination with the complex probiotic "Rioflora Balance Neo" has high clinical efficacy, based on the eradication of periodontal pathogenic and fungal microflora, local cytokine balance at levels of IL-4, IL-6 and IL-17 in the oral fluid and prolongs remission of periodontitis within 6 months in 86.4% of patients [2].

The participation of yeast-like fungi of the genus Candida in the development of periodontitis determines the relevance of the development of adequate methods of conservative treatment. Over the past 10-15 years, new antifungal drugs have entered clinical practice, the use of which in candida-associated periodontitis has not been substantiated until recently. Taking this into account, we conducted a comparative study of the sensitivity of fungal strains isolated in candida-associated periodontitis to nystatin and "new" fungicidal preparations from the ketoconazole group using the diffusion method of discs. It was found that the maximum diameter



of the growth inhibition zones was observed when using discs with fluconazole (Diflucan, Pfizer, France) and itraconazole (Orungal, Jansen Silak, Belgium). Based on the data of in vitro studies and taking into account the sensitivity of *Candida* strains isolated from patients with periodontitis, indications have been developed for combined chemotherapy of candida-associated periodontitis, using itraconazole (orungal) and fluconazole (diflucan) [10].

*Candida*-associated periodontitis in the exacerbation stage is accompanied by pronounced changes in the cellular and humoral links of immunity and is characterized by an increase in the relative and absolute number of total lymphocytes, B - lymphocytes, immunoglobulins M, G of blood serum and oral fluid, a decrease in the relative and absolute number of T - lymphocytes, a decrease in immunoglobulin A of blood serum and oral fluid, secretory immunoglobulin A of the oral fluid, lysozyme, phagocytic activity of neutrophils, the appearance of immunoglobulins M and G in the gingival fluid, as well as an imbalance of subpopulations of T-lymphocytes cells (CD4 +, CD8 + cells) and cytokines in the oral fluid. A two-component probiotic, including *Bacillus Subtilis* 11B and *Bacillus Licheniformis* 31, has a high antagonistic activity against fungi of the genus *Candida* and periodontal pathogenic microflora, and its inclusion in the treatment of candida-associated periodontitis is justified [6,11,12].

We can say that in the treatment of diseases of the oral mucosa, medicinal herbs can be used, which have a more gentle effect, practically having no contraindications. Such funds can show high efficiency in the preventive purposes of preventing mucosal diseases. They can also be combined with a systemic approach to treating diseases of the oral cavity [8].

The studied studies help us to uncover the issue in the application of tactics for the treatment of candida-assisted periodontitis. In most cases, traditional methods of treating generalized periodontitis are not excluded and give significant positive dynamics.

#### REFERENCES:

1. Avezova S.M. / Generalized periodontitis. Academic research in educational sciences 2 (5), 1536-1538 // ARES 2021-05 – Volume 2 – Issue 5 – pp.1536-1538 // DOI: 10.24411/2181-1385-2021-01065
2. Beibulatov G. Zh. - Abstract. Improving the diagnosis and treatment of chronic generalized periodontitis associated with candidal infection - 2015 - p. 10-20.
3. Borovsky, E.V. et al. Therapeutic dentistry / E.V. Borovsky. -M.: Medicine, 2006.736 p.
4. Chepurkova O.A. - Abstract. Candida-associated periodontitis. Diagnostics. Treatment - 2010 - pp. 28-33.
5. Dmitrieva, L.A. Periodontitis / L.A. Dmitrieva. - M.: MED-press-inform. 2007. -- 504 p.
6. Khanov T.V. - Abstract. Optimization of the complex treatment of candida-associated periodontitis - 2019 - p. 12-19.
7. Komleva A.S. - Abstract. Optimization of conservative treatment of patients with chronic generalized periodontitis associated with candida flora - 2010 - pp.15-21.
8. Makhmudjonovna S.A. Application of healing herbs in diseases of the mucosa of the oral cavity (literature review). ACADEMICIA: An International Multidisciplinary Research Journal 11 (6), 67-71.



9. Mirsaeva F.Z., Khanov T.V. - Dynamics of clinical and immunological indicators in the complex treatment of candida-associated periodontitis / Problems of dentistry 2019, volume 15, no. 2, pp. 128-134.
10. Nosik A.S. - Abstract. Development of methods for laboratory diagnosis and treatment of candida-associated periodontitis - 2004 - pp. 13-19.
11. Sergeev, A. Yu. Candidiasis. The nature of infection, mechanisms of aggression and protection, laboratory diagnostics, clinical picture and treatment / A.Yu.Sergeev, Yu.V. Sergeev. M.: "Triada-X", 2001. – 472p.
12. Tsarev, V.N. R.V. Ushakov Antimicrobial therapy in dentistry / V.N. Tsarev, R.V. Ushakov. M.: MIA, 2004. -- 144 p.

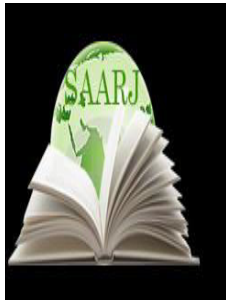

**ACADEMICIA**  
**An International  
 Multidisciplinary  
 Research Journal**  
 (Double Blind Refereed & Peer Reviewed Journal)

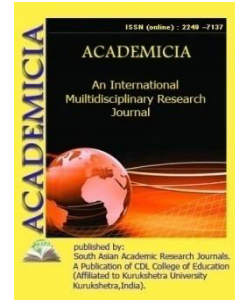

**DOI: 10.5958/2249-7137.2021.01981.9**

**METHODOLOGICAL APPROACHES TO ANALYSIS AND  
 ASSESSMENT OF IMPLEMENTATION ENERGY SAVING POTENTIAL  
 OF REAL ESTATE PROPERTIES AT THE CITY LEVEL: FORM,  
 TECHNOLOGY, RESOURCES**

**Akhrorova S.T\*; Pulatov Sh.A\*\***

\*Teacher,

Department "Cost Engineering and Real Estate Examination,  
 UZBEKISTAN

Email id: Messiolimjon1212@gmail.com

\*\*Teacher,

Department "Cost Engineering and Real Estate Examination,  
 UZBEKISTAN

Email id: shaxron.pulatov.90@mail.ru

**ABSTRACT**

*In many countries of Europe, Asia and the United States, innovative energy-saving technologies are already widely used, allowing for energy-efficient construction, modernization and reconstruction and minimizing energy consumption when operating real estate objects, and all these activities are actively developed with direct support at the state level. In terms of technology, Uzbekistan is far behind the so-called "civilized world" in many respects. Energy-efficient technologies are no exception. The main constraint in the construction of new types of industrial and non-industrial real estate was previously considered to be their relative high cost. According to the calculations of design organizations, today the cost of building 1 m<sup>2</sup> of energy-efficient real estate for industrial and non-industrial purposes is almost equal to the same indicator for conventional real estate for industrial use.*

**KEYWORDS:** *Economic Efficiency, Economically Justified, Practical Minimum.*

## INTRODUCTION

Energy efficiency of real estate objects is an integral and necessary component of the economic efficiency of the functioning of these objects and the activities of economic entities in whose administration these objects are located.

There are several approaches to determining energy efficiency:

- Energy efficiency as the achievement of economically justified efficiency in the use of fuel and energy resources at the current level of development of technology and technology and compliance with the requirements for environmental protection;
- energy efficiency as the use of less energy in order to provide the same level of energy supply for buildings or technological processes in production<sup>1</sup> [1].

In general, energy efficiency is a set of characteristics that reflect the ratio of the beneficial effect from the use of energy resources to the costs of energy resources produced in order to obtain such an effect, in relation to the housing stock, in particular to multi-apartment real estate for industrial and non-industrial purposes.

In accordance with the level of specific energy consumption for the production of a unit of products, works or services, several categories of energy efficiency can be distinguished:

Theoretical minimum, defined as the minimum possible, in accordance with the laws of thermodynamics, specific energy consumption required to perform a certain work or transform materials;

- practical minimum, determined by the best and practically achieved in the world indicators of specific energy consumption using technologies that have proven their effectiveness;
- Real consumption abroad, determined by the average or most common indicators of specific energy consumption in other countries;
- Average consumption in Uzbekistan, determined by the average indicators of specific energy consumption in Uzbekistan;
- The best regional indicators, determined by the best practically achieved in the region indicators of specific energy consumption;
- The average regional indicator, determined by the average statistical value of the specific energy consumption in the region. This indicator was used to assess the potential for energy efficiency improvements;
- The worst regional indicator, determined consumption and energy intensity of equipment, process, facility with the worst performance indicators in the region according to statistical reporting.

### Main part

The energy saving potential of a property in each sector is defined as the product of the level of economic activity in this sector by the difference between the actual (regional average) specific energy consumption for the production of a unit of production, work or service for the base year and the "practical minimum" - the value of the specific consumption for the most energy efficient

technologies, technical means or buildings used in the production of similar products, works or services.

Of all the components of the energy saving potential, three main ones can be distinguished for a property:

- **technical or technological** - evaluated on the assumption that all equipment is instantly replaced with the best samples corresponding to the “practical minimum” specific consumption; This component of the energy saving potential of the property shows only hypothetical energy saving possibilities without taking into account the costs and other restrictions on the realization of this potential. It can be judged as a result of “shaving off” the red zone (low score) or the red and yellow zones (high score). To assess the technical potential of energy saving of the property, information was used only on already practically tested technologies;

- economic - arising from the technical potential, and that part of it that is most economically attractive when using public criteria for making investment decisions: discount rate%, imputed energy price (export price of natural gas), environmental and other additional costs (for example, carbon prices ). The implementation of this component of the energy saving potential of a property requires time, determined by the speed of replacement of the main energy-consuming equipment;

- market - resulting from the economic component of the energy saving potential, the consideration of which is economically expedient when applying particular criteria for making investment decisions in real market conditions (actual prices for equipment and energy carriers, taxes, etc.)

Let us characterize three main differences in assessing economic and market potentials:

1. the procedure for making investment decisions - centralized or decentralized (due to this difference in a planned economy, all other things being equal, energy intensity is always two or more times higher than in a market economy); discount rates - value of money and perception of risk (12% for industry and 33-50% for households);
2. the composition of the effects - real rather than imputed prices, accounting for taxes and benefits, the inclusion of additional environmental and other costs (the higher opportunity cost of capital for households is due to a number of reasons: households, as a rule, are less willing to take risks associated with investments in energy saving measures );
3. the implementation of significant capital investments requires credit injections at interest rates set for private borrowers; or, in the presence of free funds, they have more important (in their eyes) areas for investment.

An important component of the methodology for assessing the energy saving potential of a real estate object and the costs necessary for its implementation is the way of accounting for the latter.

A radical increase in the energy efficiency of the Uzbekistan and regional economies is possible only if a significant part of the accumulated fixed assets is modernized and renewed. However, the main task of their modernization and renovation is not only to improve energy efficiency, but also (to a greater extent) to maintain operability, increase the reliability and overall productivity of fixed assets, generate additional income and reduce costs and harmful environmental impacts.

Improving energy efficiency and reducing energy costs is only one of the effects of modernization and renovation. Therefore, the concept of incremental capital costs is used in project costing.

When justifying many energy efficiency projects, not incremental, but full capital costs are estimated, since the cost of equipment is not broken down into parts that make it possible to continue or increase the production of goods and services and give the effect of reducing energy consumption. Therefore, the cost of projects to improve energy efficiency is often overestimated by 2-4 times, and only the cost of saving energy is assessed as an effect.

Incremental capital costs are calculated as the difference between the cost of equipment for an energy-saving project, the characteristics of which correspond to high energy efficiency classes or the best foreign technologies, and the capital costs of installing new equipment with an average or low level of energy efficiency, comparable to the efficiency of equipment that is currently in operation. In Uzbekistan (for example, the difference in the cost of a high-efficiency electric motor and an electric motor of the middle efficiency class). In some cases, when the only investment goal is to improve energy efficiency, for example, when installing a variable speed drive or metering devices, the full capital costs were used in the calculation.

To assess the economic and market potentials, the average Uzbekistan data on specific incremental capital investments were taken, which were estimated as part of the development of the State Program "Energy Saving and Energy Efficiency Improvement in the Uzbekistan Federation for the Period up to 2020".

To determine the economic and market potential, the cost of energy savings (CSE) was estimated using the following formula:

$$CSE = (CRF \times Cc + Cop) / ASE \quad (1)$$

where:  $Cc$  - incremental capital costs for the implementation of the measure;  $Cop$  - change in operating costs or additional effects (output growth, quality improvement, etc.);  $ASE$  - annual savings of final energy;  $CRF$  - capital investment reduction factor (standard capital efficiency factor). attachments), which is calculated by the formula:

$$CRF = dr / (1 - (1 + dr)^{-n}) \quad (2)$$

where:  $dr$  - discount rate;  $n$  - equipment service life.

When assessing the economic potential, a discount rate of 6% was used, and when calculating the market potential - 12% for all investments. Each type of equipment has its own service life<sup>2</sup>...

Additional Costs or Benefits ( $Cop$ ) may include annual changes in operating costs, elimination of the need for capital investments, or elimination of external factors relevant to a specific energy efficiency project. Benefits (for example, increased product output due to increased reliability and reduced maintenance downtime, reduced repair and recovery costs, reduced scrap rates due to automation and improved working conditions, etc.) are reflected as negative costs in  $Cop$ .

For each event, the scale of the final energy savings was assessed. By ranking measures by cost, you can build an energy saving curve. In fact, two curves are plotted: for public and private discount rates. The intersection of the first one with the imputed energy price (natural gas price)

gives an estimate of the economic potential, and the second one with the average energy price - the market one. Obviously, both potentials increase as energy prices rise.

Estimating the additional costs and benefits (Cop) is extremely important for estimating the energy saving cost curve (SES), although it is quite complex. In a special study evaluating the additional effects from the implementation of 81 energy-saving projects in the United States, it was concluded that they increase the effect from the implementation of projects by an average of 44% and reduce the payback period of such projects to 1 year. It is the presence of such effects that can lead to the fact that the cost of saving energy can be negative.

Special attention needs to be paid to justifying additional costs and benefits. Their assessment for energy efficient technologies in industry (according to the list of energy-intensive products produced in three regions), as well as in other sectors, is shown in Table. 1.

There are the following principles for increasing energy efficiency<sup>3</sup>: [1].

1. Wise use of energy resources
2. Stimulating energy saving
3. Energy saving design

**TABLE 1 ESTIMATES OF ADDITIONAL EFFECTS AND COSTS FROM THE IMPLEMENTATION OF MEASURES TO IMPROVE ENERGY EFFICIENCY**

Production of a product, service, or work	Additional effect rubs. / Here	Additional costs	Notes (edit)
Power engineering			
Power generation			An additional effect is determined by a decrease in expenses for capital and current repairs of equipment and an increase in electricity generation by reducing emergency and repair downtime of equipment and a corresponding increase in its operating capacity
Electricity transmission (transportation)	12127	79	An additional effect is determined by a reduction in operating costs for routine maintenance and repairs of electrical networks, transformer substations and substations. Additional costs are determined by the need for servicing AIMSUE, dispatching systems and operational power supply management.



Production of a product, service, or work	Additional effect rubs. / Here	Additional costs	Notes (edit)
<b>Heat power engineering</b>			
Heat production in boiler houses			An additional effect is determined by a decrease in the cost of capital and current repairs of equipment and an increase in heat production due to a decrease in emergency and repair downtime of equipment
Heat energy transport			An additional effect is determined by a decrease in expenses for capital and current repairs of equipment of heating networks and an increase in the supply of heat energy by reducing emergency and repair interruptions in heat supply
<b>Industry</b>			
Iron reproduction	496		An additional effect is determined by an increase in the production of iron ore (iron ore concentrate) during the modernization and / or reconstruction of technological production
Production of iron ore pellets	299		An additional effect is determined by an increase in the production of iron ore pellets during the modernization and / or reconstruction of technological production
Sinter production (sinter production)	2100	1084	An additional effect is determined by an increase in sinter output during the modernization and / or reconstruction of sinter production. Additional costs are due to the need to purchase iron ore concentrate (ore) to provide additional sinter production

Production of a product, service, or work	Additional effect rubs. / Here	Additional costs	Notes (edit)
Coke production	1156	724	An additional effect is determined by an increase in coke output during the modernization and / or reconstruction of coke-chemical plants. Additional costs are due to the need to purchase coal to provide additional volume of coke production
Pig iron production (blast furnace production)	1333		An additional effect is determined by an increase in the production of pig iron during the modernization and / or reconstruction of blast furnaces. Reconstruction of blast furnaces with the installation of bell-less charging devices allows to increase the technological capacity of blast furnace production by an average of 10-25% and does not require an additional increase in coke consumption for pig iron production
BOF steel production	27695	16023	An additional effect is determined by an increase in steel output during the modernization and / or reconstruction of converters. Additional costs are due to the need to purchase (produce) pig iron to ensure additional production of BOF steel
Electric steel production	35778	8178	An additional effect is determined by an increase in steel output during the modernization and / or reconstruction of electric furnaces. Additional costs are due to the need to purchase

Production of a product, service, or work	Additional effect rubs. / Here	Additional costs	Notes (edit)
			scrap metal to provide additional steel production
Production of rolled ferrous metals	257	-	An additional effect is determined by an increase in the output of rolled ferrous metals during the modernization and / or reconstruction of rolling mills.
Aluminum production	1825		An additional effect is determined by the following factors: 1. An increase in the production of aluminum during the modernization and / or reconstruction of technological production; 2. Reducing the consumption of anodes in the production of aluminum
Cardboard production	1884	-	An additional effect is determined by an increase in the output of cardboard during the modernization and / or reconstruction of technological production (cardboard machines - CDM).
Paper production	2569	-	An additional effect is determined by an increase in paper output during the modernization and / or reconstruction of technological production (paper machines - PM).
<b>Housing sector</b>			
Modernization of lighting systems	3160		Savings on the purchase of lamps due to the significantly longer service life of compact fluorescent lamps compared to incandescent lamps

## LIST OF USED LITERATURE

1. Mirziyoyev, ShavkatMironovich. We will all together build a free, democratic and prosperous state of Uzbekistan. Speech at the inauguration ceremony of the President of the

- Republic of Uzbekistan at a joint meeting of the chambers of the Oliy Majlis / Sh.M. Mirziyoyev. - Tashkent: Uzbekiston, 2016 .-- 56 p.
2. Mirziyoyev, ShavkatMiromonovich. Critical analysis, tough discipline and personal responsibility should become a daily routine in every leader's activities. Report at an expanded meeting of the Cabinet of Ministers dedicated to the results of the country's socio-economic development in 2016 and the most important priority areas of the economic program for 2017. / Sh.M. Mirziyoyev. - Tashkent: Uzbekiston, 2017 .-- 104 p.
  3. Resolution of the President of the Republic of Uzbekistan "On further improving the activities of appraisal organizations and increasing their responsibility for the quality of services provided" No. PP - 843 of 24.04.2008 .
  4. Golikova G.A. Organizational and economic model of energy saving management in housing and communal services: diss ... cand. econom. Sciences, Volgograd, VolGASU, 2014 - p. 218, p. 53
  5. Ganiev K.B. , Ganieva G.I. et al. Enterprise economics: Market of dental machines and equipment: a tutorial. / Ed. doc. technical sciences, prof. Ganieva K. B. - T: Publishing House of the National Society of Philosophers of Uzbekistan, 2006. - 160 p.
  6. Ganiev K.B. Ganieva G.I. Real estate appraisal, study guide - Tashkent, publishing house "Konsauditinform - Nashr, 2010-232 p.
  7. Maksimchuk O.V., Pershina T.A., PonomarevaE.Yu., Pastel E.V., ChulanovaYu.Yu. Results of compulsory energy survey of the state budgetary educational institution of secondary vocational education "Volgograd Construction College" Deposited manuscript No. 65-B2016 04/25/2016
  8. Ganiev. K.B .. Ganieva. G.I. Ganieva F.K. Real estate appraisal (measures and tasks) / Study guide - Tashkent. published by "NisoPoligraf. 2015 - 160 p.
  9. Yodgorov V.U., Mirjalilova D.SH. Organizing and managing the use of real estate. Textbook.-T .: Tashkent Institute of Architecture and Construction, 2014. -200 p.
  10. [www.gov.uz](http://www.gov.uz). (Official website of the Government of the Republic of Uzbekistan).
- [www.gki.uz](http://www.gki.uz) (State Property Committee of the Republic of Uzbekistan).
- [www.sion.uz](http://www.sion.uz) (Real Estate Agency)
- [www.wikipedia.ru](http://www.wikipedia.ru) (Information search portal)

## Editorial Board

**Dr. B.S. Rai,**  
Editor in Chief  
M.A English, Ph.D.  
Former Principal  
G.N. Khalsa PG.College,  
Yamunanagar, Haryana, INDIA  
Email: balbirsinghrai@yahoo.ca

**Dr. Romesh Chand**  
Professor- cum-Principal  
CDL College Of Education,Jagadhri,  
Haryana, INDIA  
Email: cdlcoe2004@gmail.com

**Dr. R. K.Sharma**  
Professor (Rtd.)  
Public Administration,  
P U Chandigarh, India  
Email: sharma.14400@gmail.com

**Dr. Mohinder Singh**  
Former Professor & Chairman.  
Department of Public Administration  
K. U. Kurukshetra (Haryana)  
Email: msingh\_kuk@yahoo.co.in

**Dr. S.S. Rehal**  
Professor & chairman,  
Department of English,  
K.U. Kurukshetra (Haryana)  
Email: srehal63@gmail.com

**Dr. Victor Sohmen**  
Professor,  
Deptt. of Management and Leadership  
Drexel University Philadelphia,  
Pennsylvania, USA.  
Email: vsohmen@gmail.com

**Dr. Anisul M. Islam**  
Professor  
Department of Economics  
University of Houston-Downtown,  
Davies College of Business  
Shea Street Building Suite B-489  
One Main Street, Houston,  
TX 77002, USA  
Email: islama@uhd.edu

**Dr. Zhanna V.Chevychalova, Kharkiv,**  
Associate Professor,  
Department of International Law,  
Yaroslav Mudry National Law University,  
UKRAINE  
Email:zhannachevychalova@gmail.com

**Dr. Kapil Khanal**  
Associate Professor of Management,  
Shankar Dev Campus,  
Ram Shah Path T.U. Kirtipur, NEPAL.  
Email:kapilkhanal848@gmail.com

**Dr. Dalbir Singh**  
Associate Professor  
Haryana School of Business, G.J.U.S & T, Hisar,  
Haryana, INDIA  
Email: dalbirhsb@gmail.com

**Nadeera Jayathunga**  
Senior Lecturer  
Department of Social Sciences,  
Sabaragamuwa University, Belihuloya,  
SRI LANKA  
Email: nadeesara@yahoo.com

**Dr. Parupalli Srinivas Rao**  
Lecturer in English,  
English Language Centre,  
King Faisal University, Al-Hasa,  
KINGDOM of SAUDI ARABIA  
Email: vasupsr@yahoo.com



## Categories

- Business Management
- Social Science & Humanities
- Education
- Information Technology
- Scientific Fields

## Review Process

Each research paper/article submitted to the journal is subject to the following reviewing process:

1. Each research paper/article will be initially evaluated by the editor to check the quality of the research article for the journal. The editor may make use of iThenticate/Viper software to examine the originality of research articles received.
2. The articles passed through screening at this level will be forwarded to two referees for blind peer review.
3. At this stage, two referees will carefully review the research article, each of whom will make a recommendation to publish the article in its present form/modify/reject.
4. The review process may take one/two months.
5. In case of acceptance of the article, journal reserves the right of making amendments in the final draft of the research paper to suit the journal's standard and requirement.

## Published by

### South Asian Academic Research Journals

A Publication of CDL College of Education, Jagadhri (Haryana)  
(Affiliated to Kurukshetra University, Kurukshetra, India)

Our other publications :

South Asian Journal of Marketing & Management Research (SAJMMR)

ISSN (online) : 2249-877X

SAARJ Journal on Banking & Insurance Research (SJBIR)

ISSN (online) : 2319 – 1422